

FUEL SYSTEM (1NZ-FXE) LOCATION

11123-01

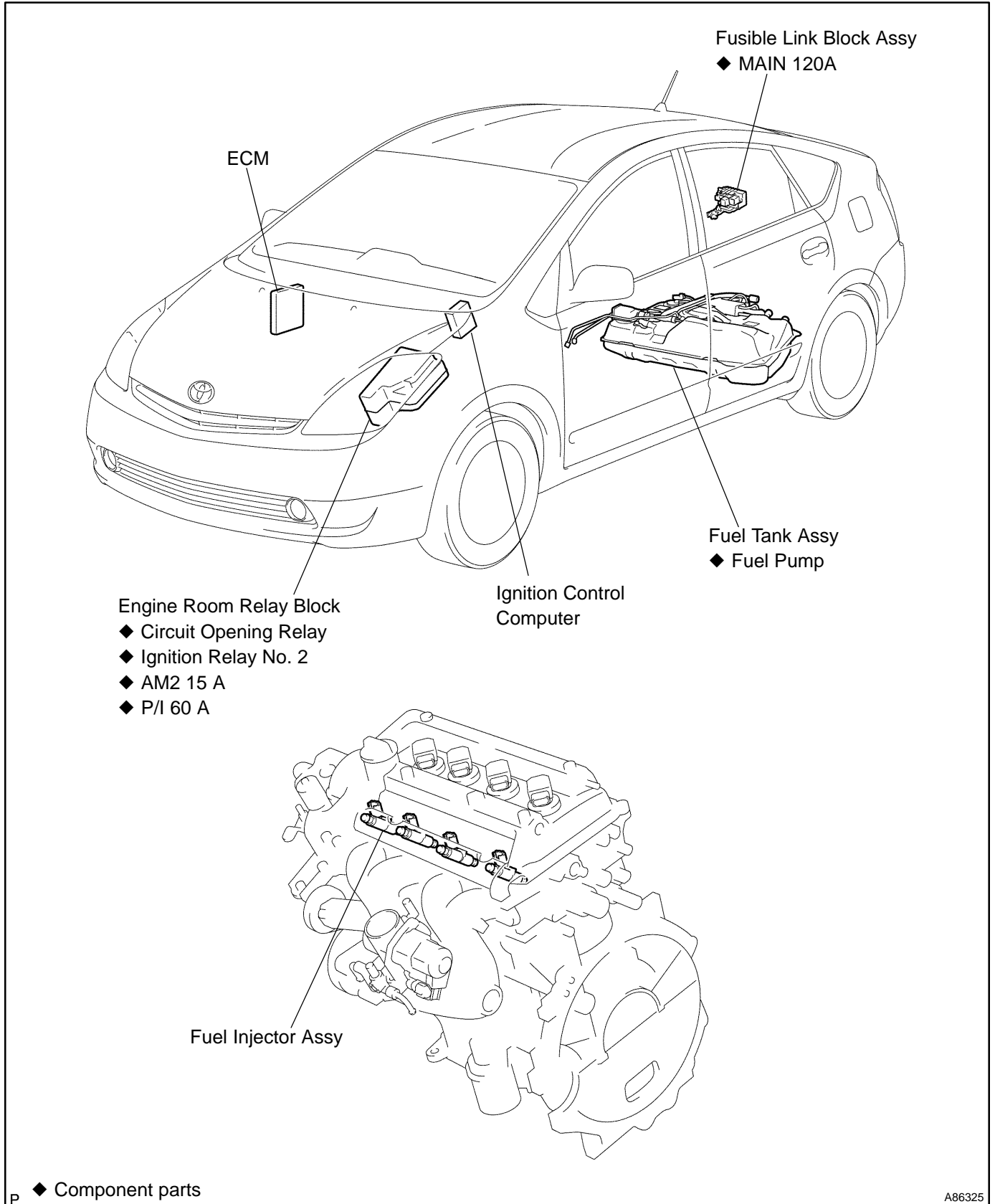

SYSTEM DIAGRAM

The fuel system is determined by the ECM based on signals from various sensors.

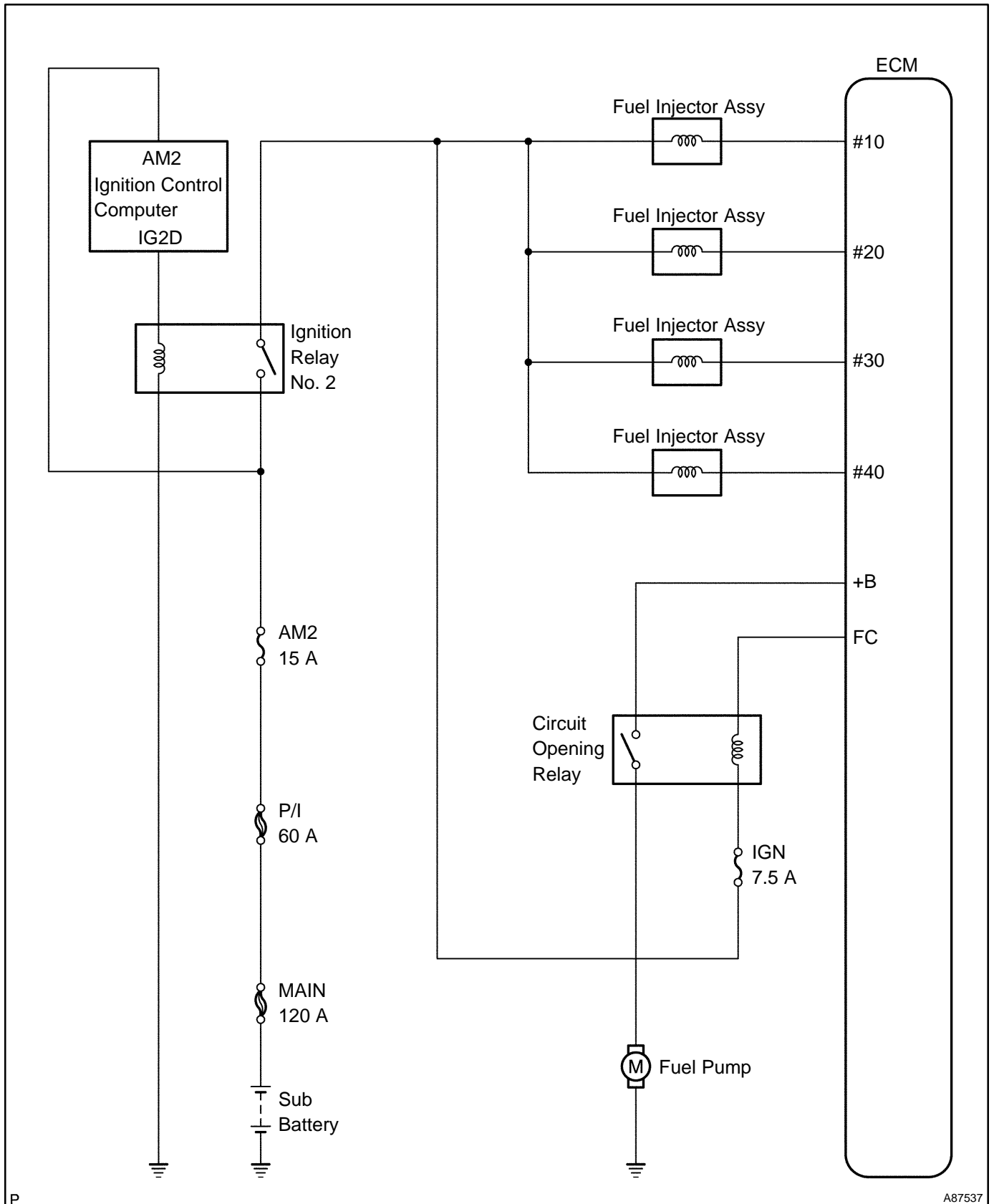

P

A87537

PRECAUTION

1. PRECAUTION

- (a) Before working on the fuel system, disconnect the engine wire No. 2 (battery negative terminal).
- (b) Do not work on the fuel system near fire. Never smoke during the work.
- (c) Keep rubber or leather parts away from gasoline.

2. DISCHARGE FUEL SYSTEM PRESSURE

CAUTION:

- ◆ Before removing the fuel system parts, take precautions to prevent gasoline spill.
- ◆ As some pressure remains in the fuel line even after taking precautions to prevent gasoline spill, use a shop rag to prevent gasoline splash when disconnecting the fuel line.

- (a) Set the vehicle to the "INSPECTION MOD1" (see page 01-5).
- (b) Remove the rear floor board No. 2 (see page 19-2).
- (c) Remove the deck floor box rear (see page 19-2).
- (d) Remove the rear floor board No. 3 (see page 19-2).
- (e) Disconnect the engine wire No. 3 (battery negative terminal) (see page 19-2).
- (f) Remove the rear seat (see page 72-9).
- (g) Remove the rear floor service hole cover.

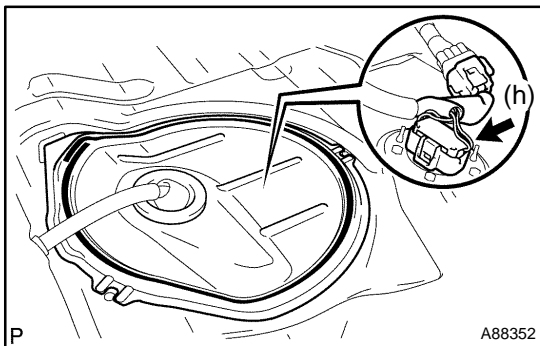

- (h) Disconnect the fuel pump connector.
- (i) Connect the engine wire No. 3 (battery negative terminal) (see page 19-2).
- (j) Start the engine.
- (k) After the engine stops (rough idle), turn the power switch OFF.

HINT:

DTC P0171 (system too lean) may be present.

- (l) Crank the engine again, then check that the engine does not start.
- (m) Remove the fuel tank cap, then discharge the pressure in the fuel tank completely.
- (n) Disconnect the engine wire No. 3 (battery negative terminal) (see page 19-2).
- (o) Connect the fuel pump connector.
- (p) Install the rear floor service hole cover.
- (q) Install the rear seat (see page 72-9).
- (r) Connect the engine wire No. 3 (battery negative terminal) (see page 19-2).
- (s) Install the rear floor board No. 3.
- (t) Install the deck floor box rear.
- (u) Install the rear floor board No. 2.

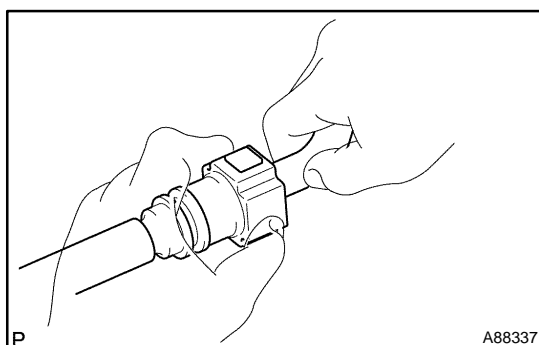
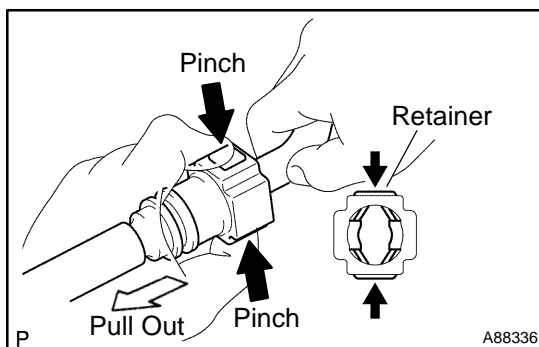
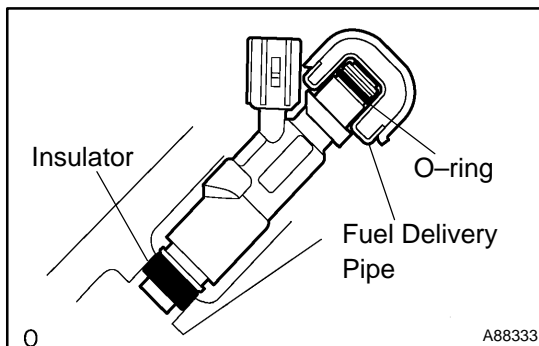
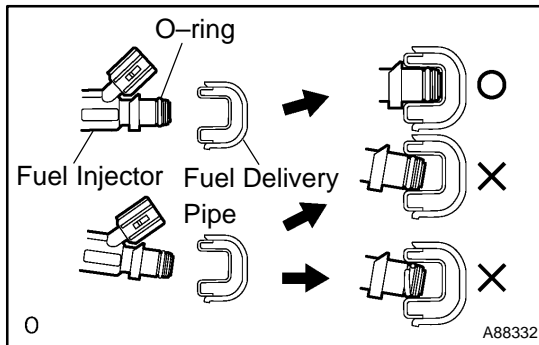
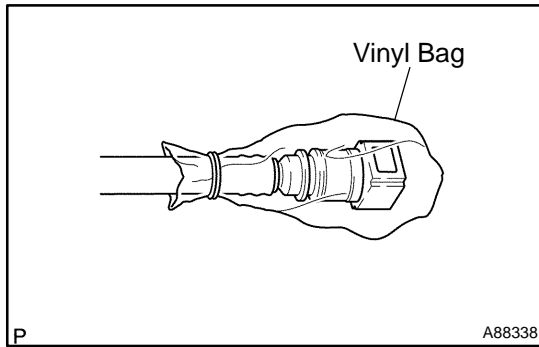

3. FUEL SYSTEM

(a) When disconnecting the high-pressure fuel line, a large amount of gasoline will splash. So take the following precautions.

- (1) Discharge the fuel system pressure (step 2).
- (2) Disconnect the fuel pump tube (see page 11-24).
- (3) Drain the pressure remaining in the fuel pump tube.
- (4) Cover the disconnected fuel pump tube (fuel tube joint and fuel tube connector) with a vinyl bag to prevent damage and intrusion of foreign objects.

(b) Take the following precautions when removing and installing the fuel injector.

- (1) Do not reuse the O-ring.
- (2) Do not damage a new O-ring when installing it to the fuel injector.
- (3) Before installing a new O-ring, apply spindle oil or gasoline.

NOTICE:

Do not use engine oil, gear oil or brake oil.

(c) Install the fuel injector to the fuel delivery pipe and cylinder head as illustrated.

NOTICE:

Apply spindle oil or gasoline to the contact surface of the fuel delivery pipe and fuel injector before installing the fuel injector.

(d) Take the following precautions when removing the fuel tube connector (Type A).

- (1) Check the fuel tube connector and pipe for dirt or mud before removing the fuel tube connector.

If dirty, wipe it off with a shop rag.

- (2) Pinch the retainer as illustrated, then pull out the fuel tube connector from the pipe.

- (3) If the fuel tube connector and pipe are stuck, pinch the pipe, then push and pull the fuel tube connector to release and disconnect the fuel tube connector.

NOTICE:

Never use any tools.

- (4) After removing the fuel tube, check the sealing surface of the pipe for dirt or mud.

If dirty, wipe it off with a shop rag.

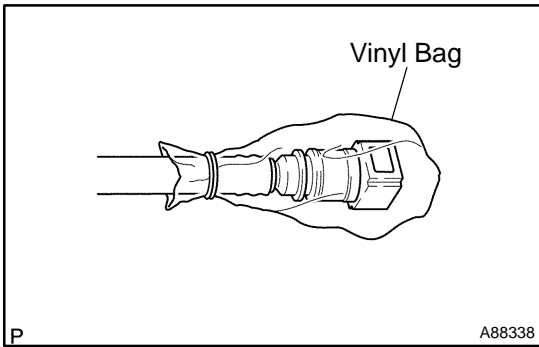

- (5) Cover the disconnected fuel tube connector and pipe with a vinyl bag to prevent damage and intrusion of foreign objects.

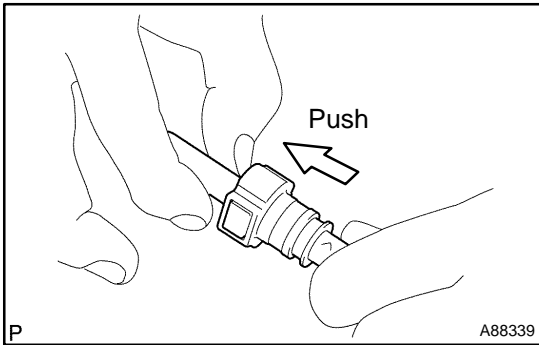

- (e) Take the following precautions when installing the fuel tube connector (Type A).
 - (1) Align the fuel tube connector with the pipe, then push in the fuel tube connector until the retainer makes a "click" sound.

HINT:

If they are connected too tightly, apply a light coat of engine oil to the tip of the pipe, then install the fuel tube connector.

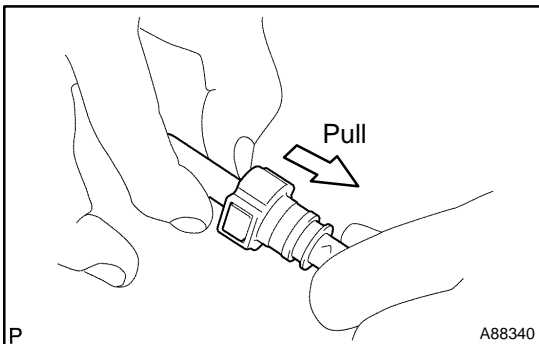

- (2) After connecting the fuel tube connector, check that the fuel tube connector and pipe are securely connected by pulling them.

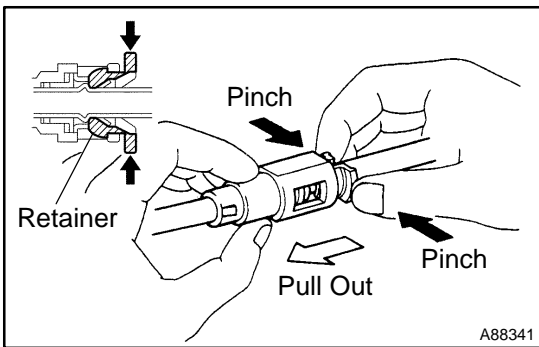

- (f) Take the following precautions when removing the fuel tube connector (Type B).

- (1) Check the fuel tube connector and pipe for dirt or mud before removing the fuel tube connector

If dirty, wipe it off with a shop rag.

- (2) Pinch the retainer as illustrated, then pull out the fuel tube connector from the pipe.

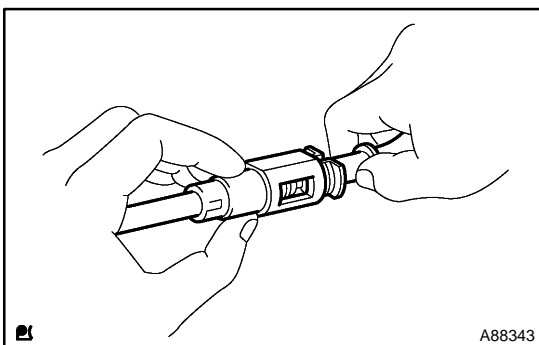

- (3) If the fuel tube connector and pipe are stuck, pinch the pipe, then push and pull the fuel tube connector to release and disconnect the fuel tube connector/

NOTICE:

Never use any tools.

- (4) After removing the fuel tube, check the sealing surface of the pipe for dirt or mud.

If dirty, wipe it off with a shop rag.

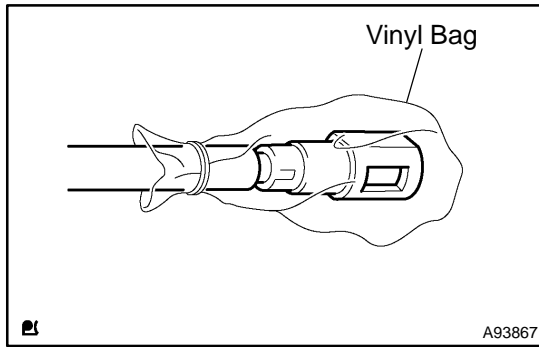

- (5) Cover the disconnected fuel tube connector and pipe with a vinyl bag to prevent damage and intrusion of foreign objects.

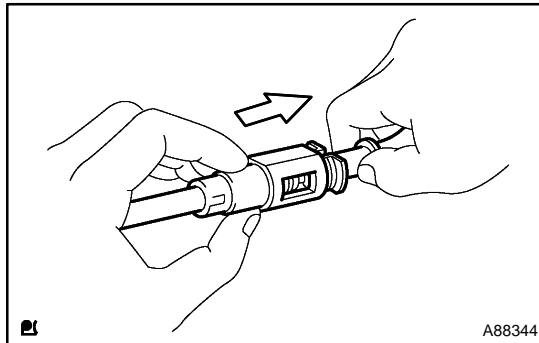

- (g) Take the following precautions when installing the fuel tube connector (Type B).
- (1) Align the fuel tube connector with the pipe, then push in the fuel tube connector until the retainer makes a "click" sound.

HINT:

If they are connected too tightly, apply a light coat of engine oil to the tip of the pipe, then install the fuel tube connector.

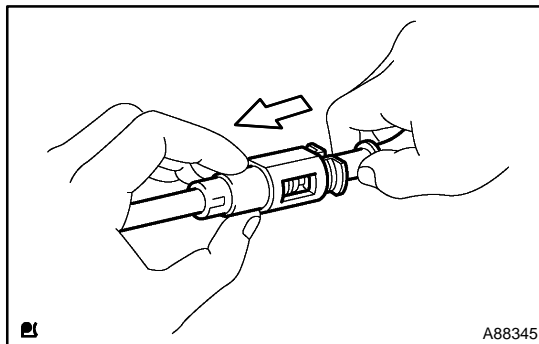

- (2) After connecting the fuel tube connector, check that the fuel tube connector and pipe are securely connected by pulling them.

4. CHECK FOR FUEL LEAKS

- (a) Check that there are no fuel leaks after doing maintenance on the fuel system (see page 11-7).

ON-VEHICLE INSPECTION

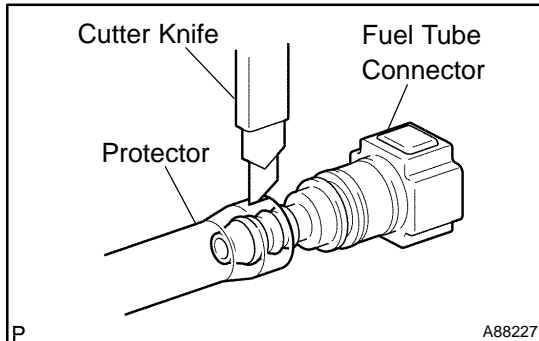

1. CHECK FUEL PRESSURE

- (a) Prepare for the inspection.
 (1) Prepare a new fuel tube.

HINT:

Part No. 23901-21080

- (2) Using a cutter knife, cut off the protector of the fuel tube as illustrated. Tear off the protector by hand, then remove the fuel tube connector.

NOTICE:

If the protector is cut too deeply using a cutter, the O-ring of the fuel tube connector will be damaged.

- (b) Discharge fuel system pressure (see page 11-3).
 (c) Remove the rear floor board No. 2 (see page 19-2).
 (d) Remove the deck floor box rear (see page 19-2).
 (e) Remove the rear floor board No. 3 (see page 19-2).
 (f) Using a voltmeter, measure battery voltage.

Standard: 9.0 to 14 V

- (g) Disconnect the engine wire No. 3 (battery negative terminal) (see page 19-2).
 (h) Disconnect the fuel tube (see page 11-15).
 (i) Install SST and the fuel tube connector to the vehicle.
 SST 09268-41047 (95336-08070), 09268-45014
 (09268-41200, 09268-41220, 09268-41250)
 (j) Wipe off the spilt gasoline.
 (k) Connect the engine wire No. 3 (battery negative terminal) (see page 19-2).

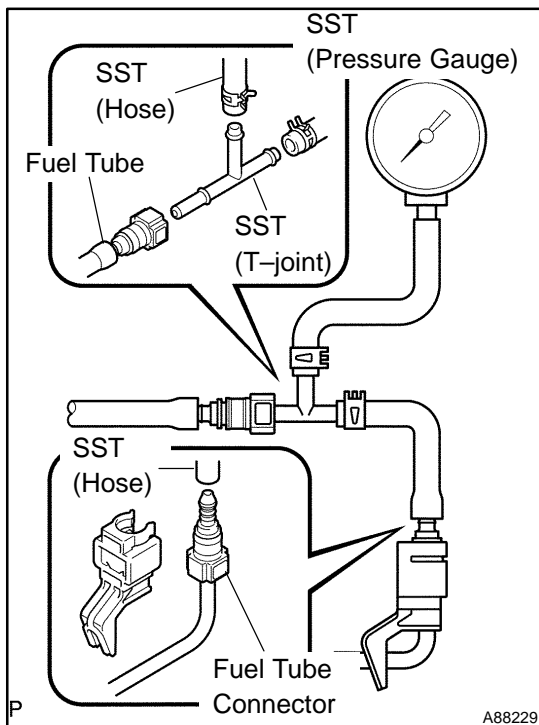

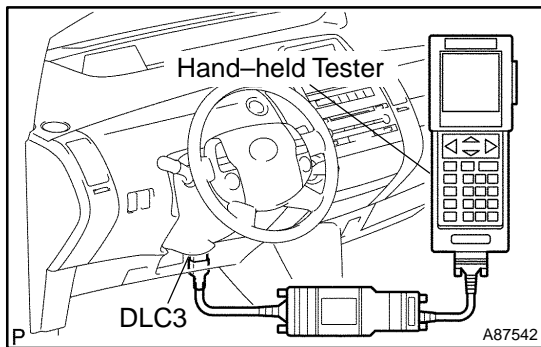

- (l) Connect the hand-held tester to the DLC3.
- (m) Measure the fuel pressure.

Standard:**304 to 343 kPa (3.1 to 3.5 kgf/cm², 44 to 50 psi)**

- ◆ If the fuel pressure is greater than the standard value, replace the fuel tank.
- ◆ If the fuel pressure is less than the standard value, check the connection of the fuel hose and the fuel tank.

- (n) Disconnect the hand-held tester from the DLC3.
- (o) Set the vehicle to the "INSPECTION MOD1" (see page 01-5).
- (p) Start the engine.
- (q) Measure the fuel pressure at idle.

Standard:**304 to 343 kPa (3.1 to 3.5 kgf/cm², 44 to 50 psi)**

- (r) Stop the engine.
- (s) After stopping the engine, check that the fuel pressure does not change for 5 minutes.

Standard: 147 kPa (1.5 kgf/cm², 21 psi) or more

If the fuel pressure is not as specified, check the fuel tank or fuel injector (see page 11-9).

- (t) After measuring the fuel pressure, disconnect the engine wire No. 3 (battery negative terminal). Remove SST and the fuel tube connector while paying attention to prevent gasoline splash.
- (u) Connect the fuel tube (see page 11-15).

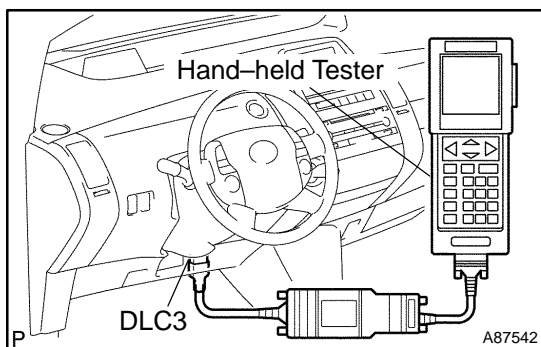
**2. CHECK FUEL PUMP**

- (a) Connect the hand-held tester to the DLC3.
- (b) Turn the power switch ON (IG).

NOTICE:**Do not start the engine.**

- (c) Turn the hand-held tester ON.
- (d) Select the item: DIAGNOSIS / ENHANCED OBD II / ENGINE AND ECT / ACTIVE TEST / FUEL PUMP / SPD.
- (e) Check the fuel pump operation while operating it with the hand-held tester II.

If the fuel pump does not operate, replace the fuel tank.

3. CHECK FOR FUEL LEAKS

- (a) Check that there are no leaks in the fuel system while fuel pressure is applied.

INSPECTION

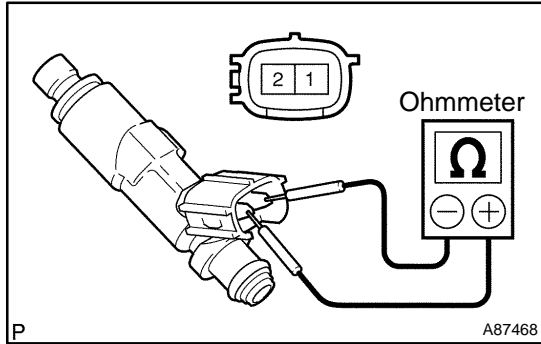

1. INSPECT FUEL INJECTOR ASSY

(a) Inspect the resistance.

- (1) Using an ohmmeter, measure the resistance between the terminals.

Standard:

Tester Connection	Specified Condition
1 - 2	13.45 to 14.15 Ω at 21°C (68°F)

If the resistance is not as specified, replace the fuel injector.

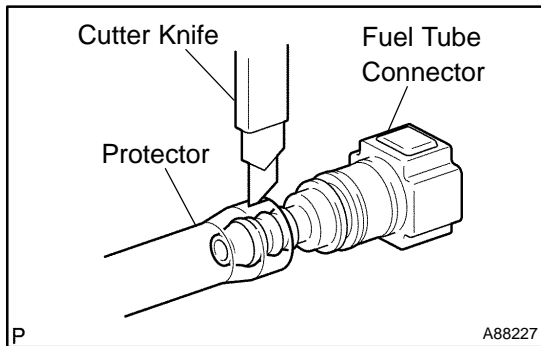

(b) Inspect the injection volume.

NOTICE:

◆ Perform the test in a well-ventilated area and watch out for flames.

◆ Carefully handle the fuel tube connector.

- (1) Prepare a new fuel tube.

HINT:

Part No. 23901-21080

- (2) Using a cutter knife, cut off the protector of the fuel tube as illustrated. Tear off the protector by hand, then remove the fuel tube connector.

NOTICE:

If the protector is cut too deeply using a cutter, the O-ring of the fuel tube connector will be damaged.

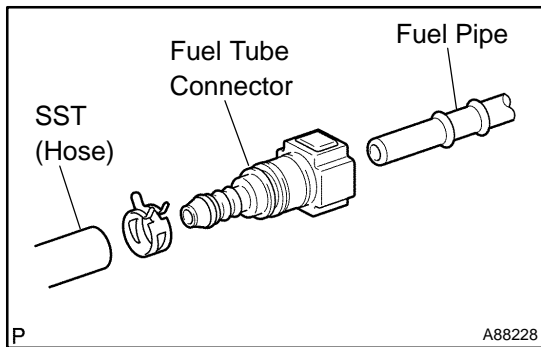

- (3) Install SST to the fuel tube connector, then connect the fuel tube connector to the fuel pipe (the vehicle side).

SST 09268-41047 (95336-08070)

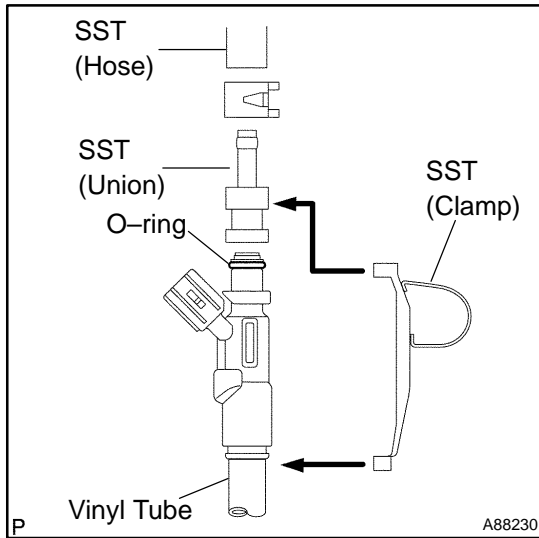

- (4) Install a new O-ring to the fuel injector.
- (5) Install SST and the vinyl tube to the fuel injector.
SST 09268-41047 (09268-41110, 09268-41300)

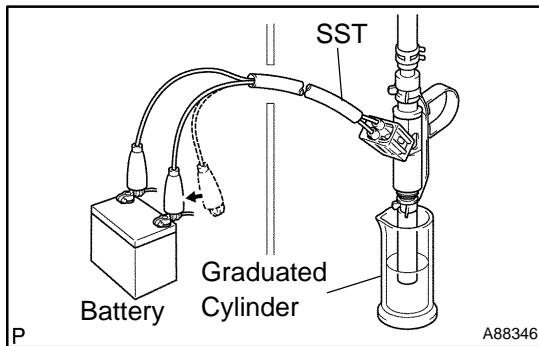

- (6) Set the fuel injector to a graduated cylinder.
- (7) Actuate the fuel pump (see page 11-7).
- (8) Install SST to the fuel injector.
SST 09842-30080
- (9) Connect SST to the battery, then measure the injection volume for 15 seconds. Perform the inspection 2 or 3 times, then calculate the average.

Standard:

Injection Volume	Difference between each fuel injector
36 to 46 cm ³ (2.1 to 2.8 cu in.)	10 cm ³ (0.6 cu in.) or less

NOTICE:

Always do the switching at the battery side.

If the injection volume is not as specified, replace the fuel injector.

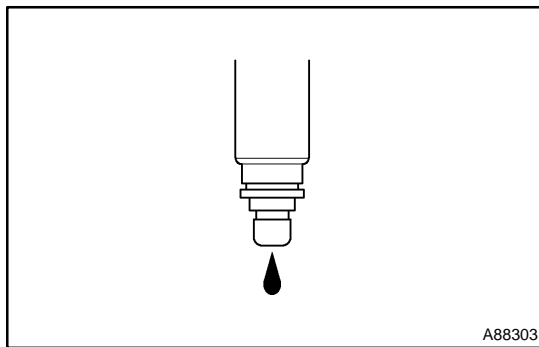

- (c) Inspect the leakage.
 - (1) In the condition that the injection volume was inspected, remove SST from the battery. Inspect the fuel leakage from the fuel injector.

Standard: 1 drop or less per 12 minutes

If the fuel leakage is not as specified, replace the fuel injector.

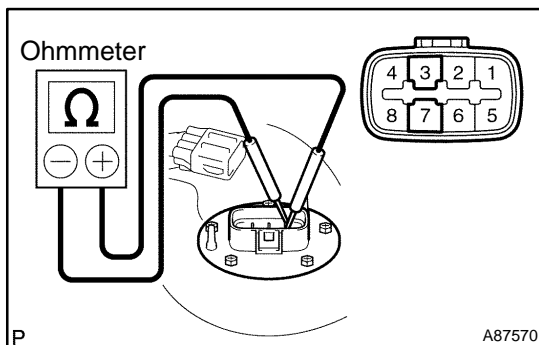

2. INSPECT FUEL TANK ASSY (FUEL PUMP)

- (a) Inspect the resistance.
 - (1) Using an ohmmeter, measure the resistance between the terminals.

Standard:

Tester Connection	Specified Condition
3 - 7	0.2 to 3.0 Ω at 20°C (68°F)

If the resistance is not as specified, replace the fuel tank.

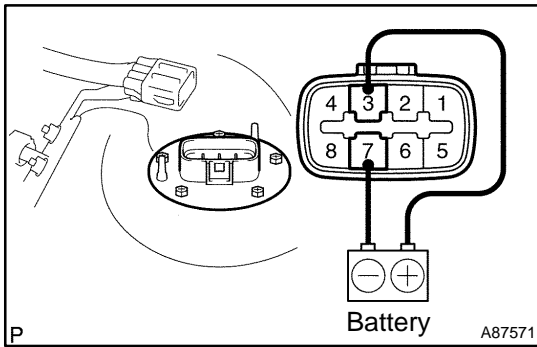

- (b) Check the operation.
- (1) Check that the motor operates when battery voltage is applied across the terminals.

NOTICE:

- ◆ Perform the check quickly (shorter than 10 seconds).
- ◆ Keep the battery as far away the fuel tank as possible.
- ◆ Always do the switching at the battery side.

If the motor does not operate, replace the fuel tank.

FUEL INJECTOR ASSY (1NZ-FXE) COMPONENTS

11112-01

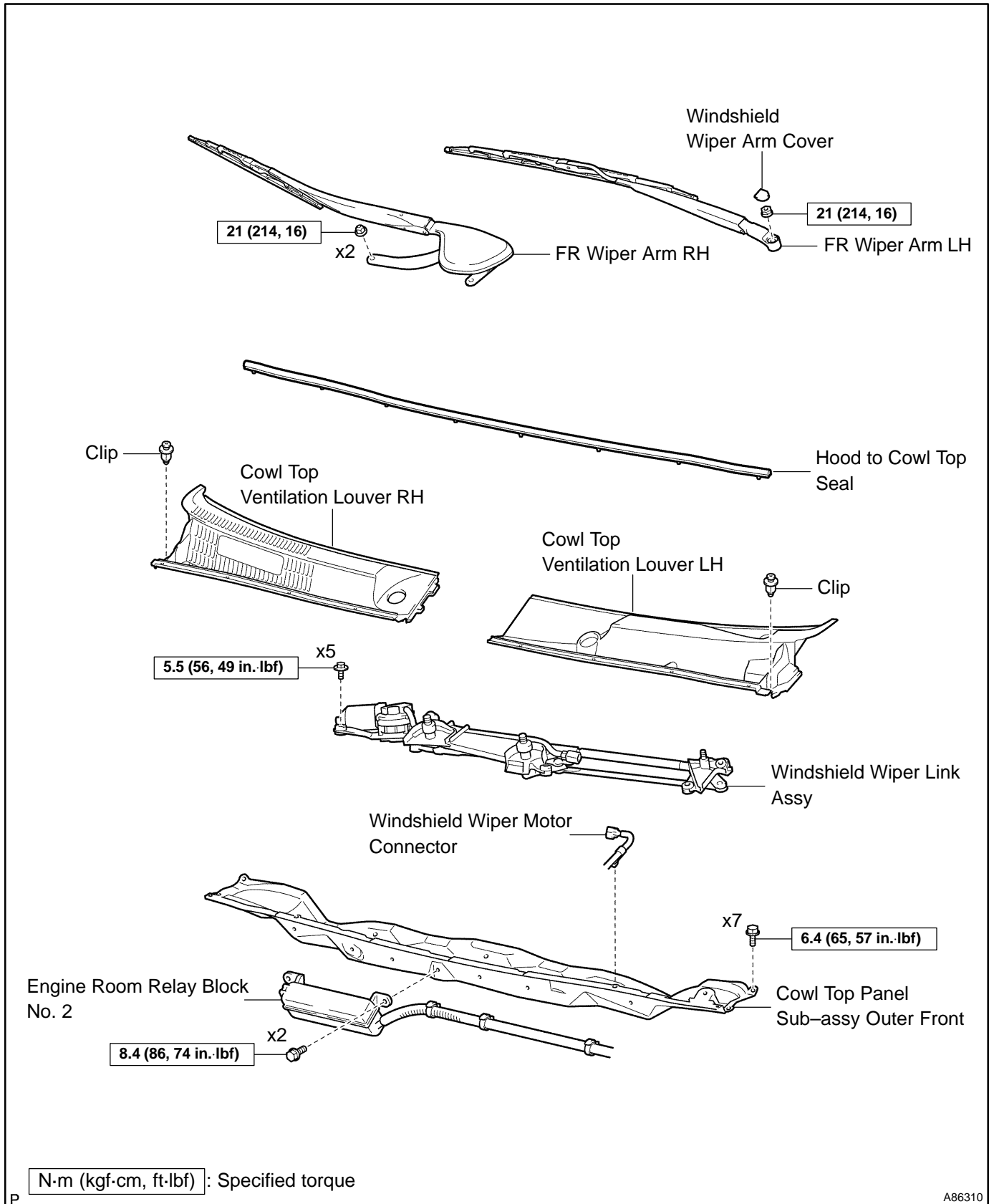

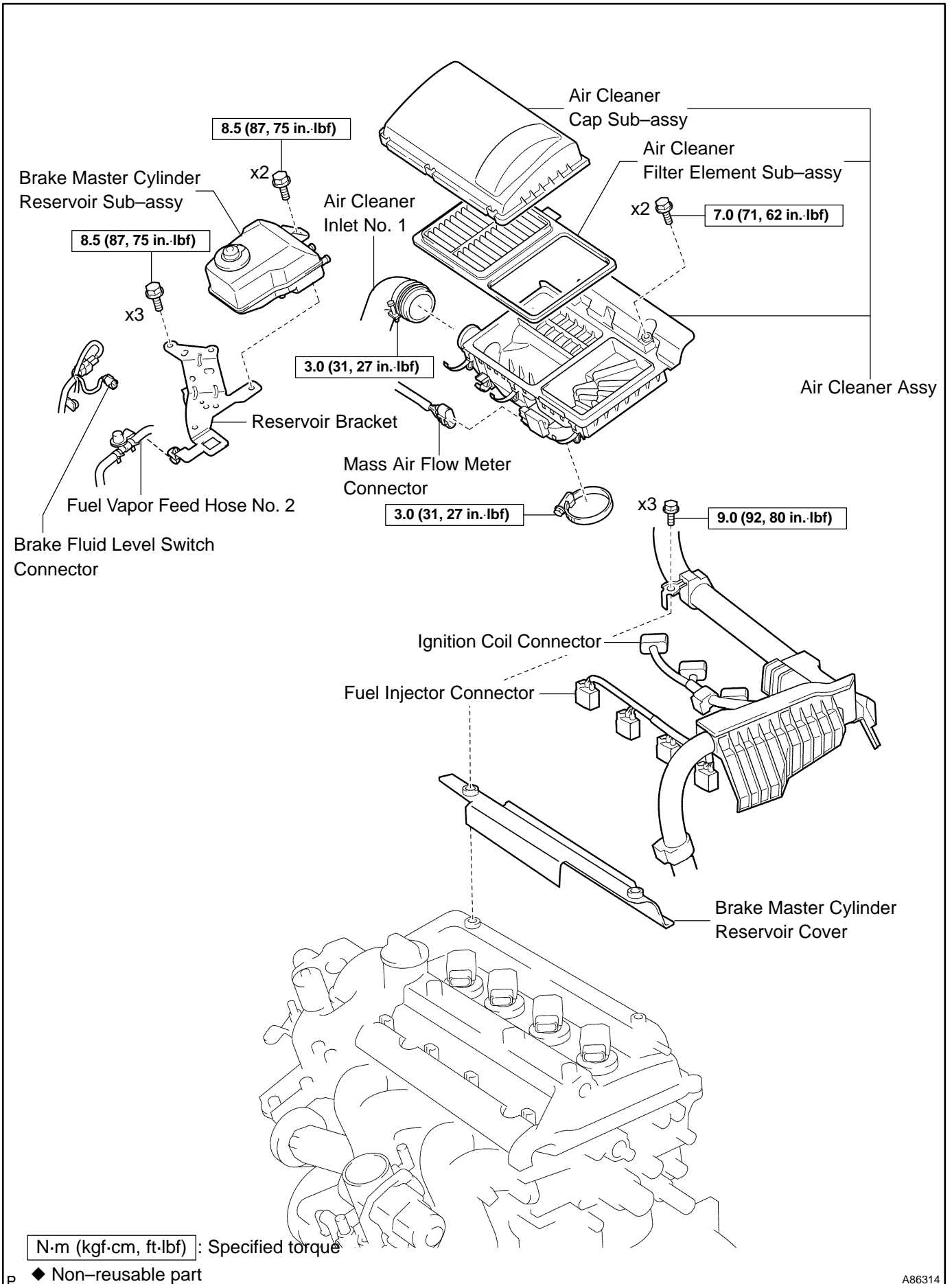

A86314

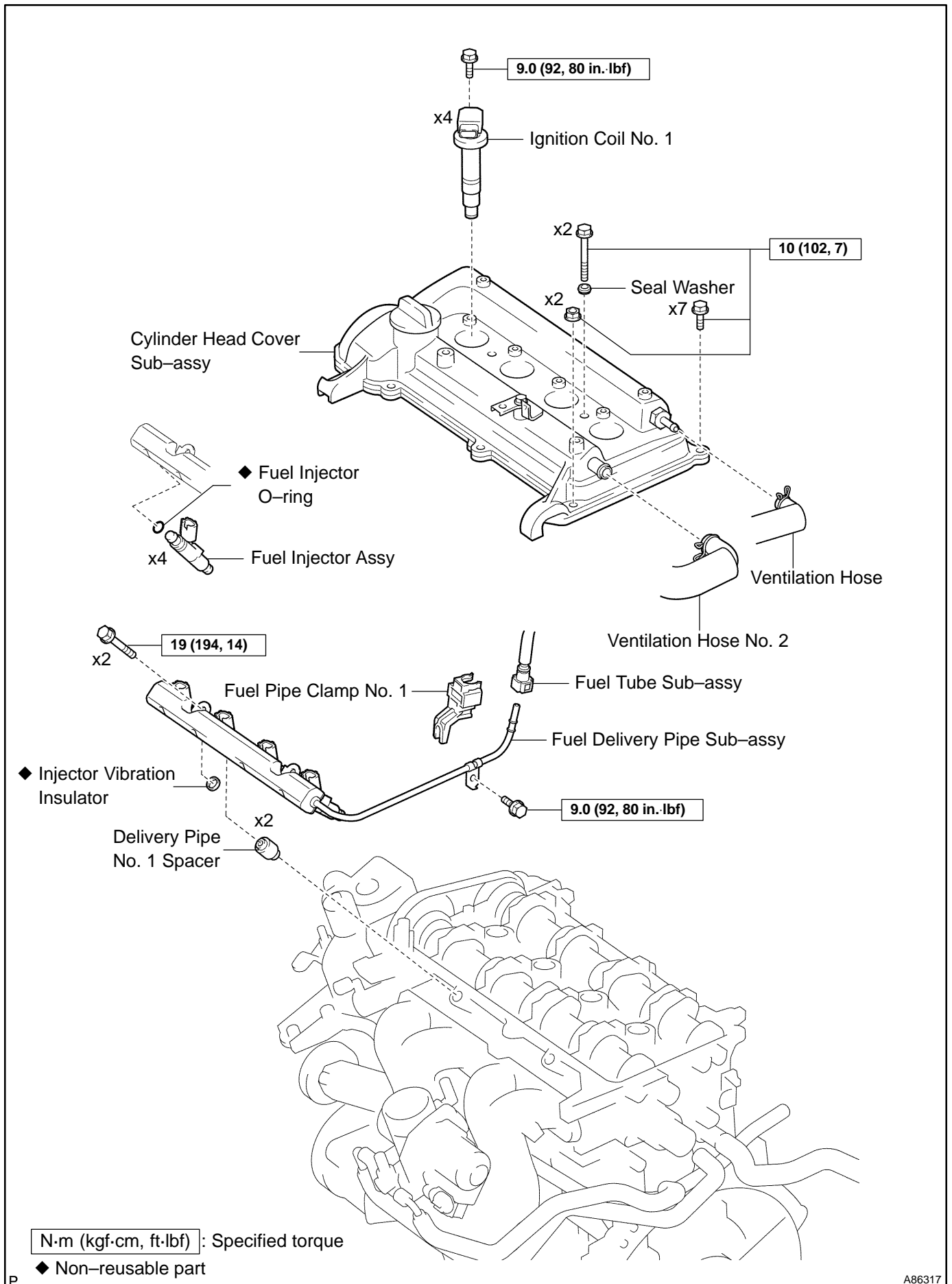

A86317

REPLACEMENT

1. DISCHARGE FUEL SYSTEM PRESSURE (See page 11-3)
2. REMOVE REAR FLOOR BOARD NO.2 (See page 19-2)
3. REMOVE DECK FLOOR BOX REAR (See page 19-2)
4. REMOVE REAR FLOOR BOARD NO.3 (See page 19-2)
5. DISCONNECT ENGINE WIRE NO.3 (BATTERY NEGATIVE TERMINAL) (See page 19-2)
6. REMOVE WINDSHIELD WIPER ARM COVER
7. REMOVE FR WIPER ARM RH (See page 66-14)
8. REMOVE FR WIPER ARM LH (See page 66-14)
9. REMOVE HOOD TO COWL TOP SEAL (See page 66-14)
10. REMOVE COWL TOP VENTILATOR LOUVER LH (See page 66-14)
11. REMOVE COWL TOP VENTILATOR LOUVER RH (See page 66-14)
12. REMOVE WINDSHIELD WIPER LINK ASSY (See page 66-14)

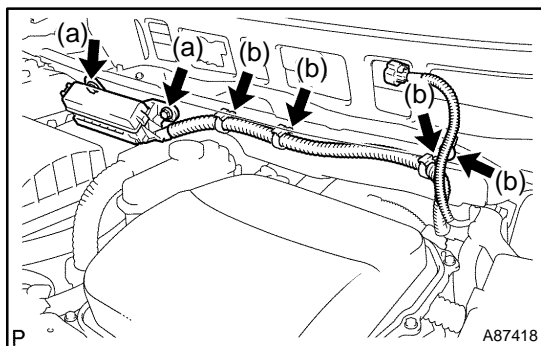

13. REMOVE COWL TOP PANEL SUB-ASSY OUTER FRONT

- (a) Remove the 2 bolts then remove the engine room relay block No. 2.
- (b) Remove the 4 wire harness clamps.

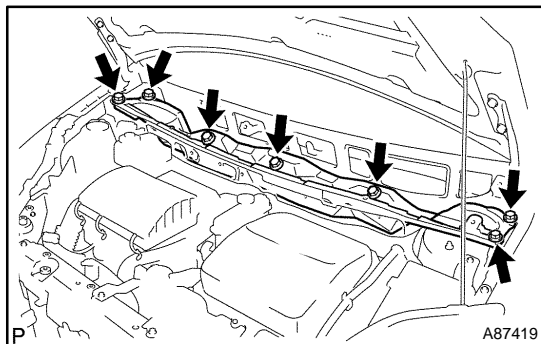

- (c) Remove the 7 bolts, then remove the cowl top panel outer front.

14. REMOVE AIR CLEANER ASSY (See page 10-15)

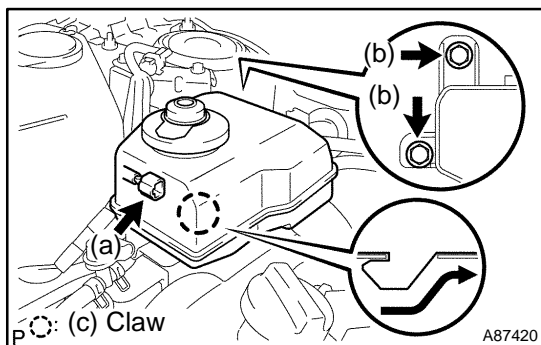

15. REMOVE BRAKE MASTER CYLINDER RESERVOIR SUB-ASSY

- (a) Disconnect the brake fluid level switch connector.
- (b) Remove the 2 bolts.
- (c) Separate the claw fitting, then remove the brake master cylinder reservoir.

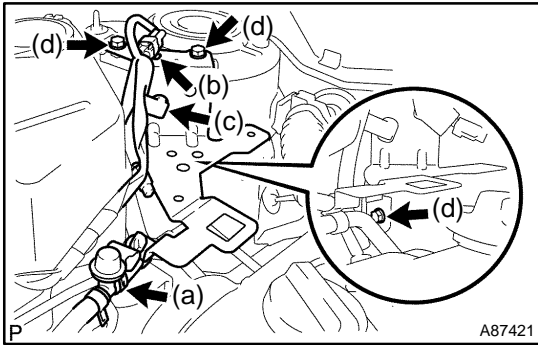

16. REMOVE RESERVOIR BRACKET

- (a) Remove the fuel vapor feed hose No. 2 from the hose clamp.
- (b) Remove the connector clamp.
- (c) Remove the wire harness clamp.
- (d) Remove the 3 bolts, then remove the reservoir bracket.

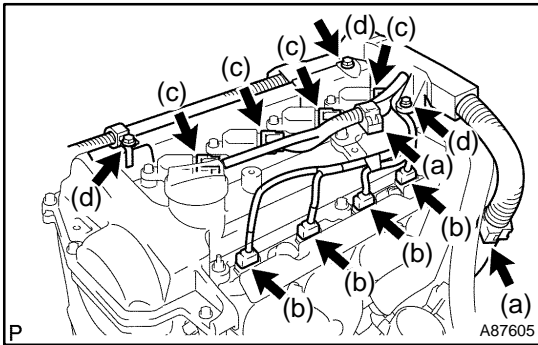

17. REMOVE CYLINDER HEAD COVER SUB-ASSY

- (a) Remove the 2 wire harness clamps.
- (b) Disconnect the 4 fuel injector connectors.
- (c) Disconnect the 4 ignition coil connectors.
- (d) Remove the 3 bolts, then remove the engine wire and brake master cylinder reservoir cover.

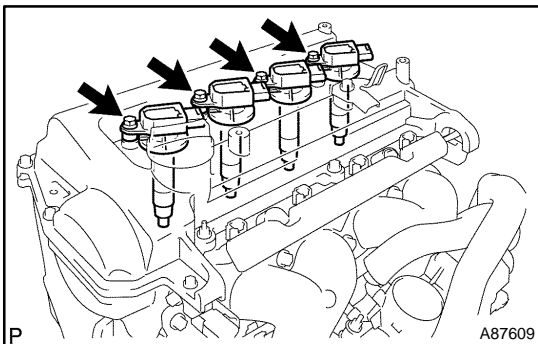

- (e) Remove the 4 bolts, then remove the 4 ignition coils.

HINT:

Each ignition coil is installed with 1 bolt.

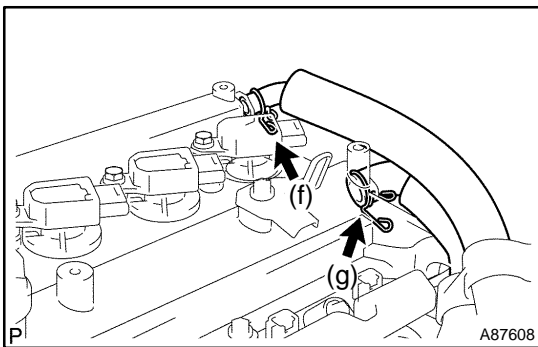

- (f) Disconnect the ventilation hose from the ventilation valve.
- (g) Disconnect the ventilation hose No. 2 from the cylinder head cover.

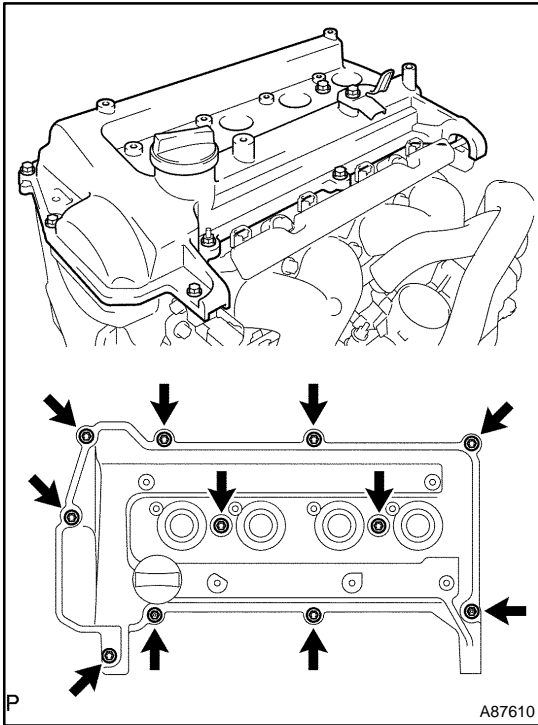

- (h) Remove the 9 bolts, 2 seal washers and 2 nuts, then remove the cylinder head cover.

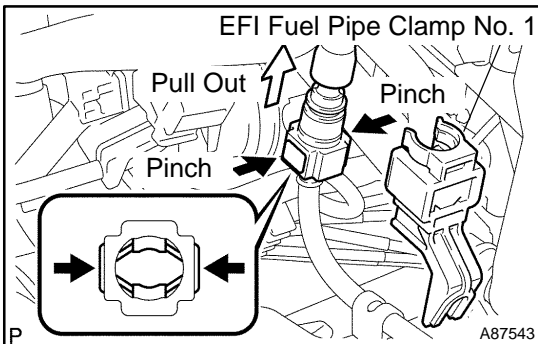

18. REMOVE FUEL DELIVERY PIPE SUB-ASSY

- (a) Disconnect the fuel tube from the fuel delivery pipe.
- (1) Remove the EFI fuel pipe clamp No. 1.
 - (2) Pinch the retainer of the fuel tube connector, then pull out the fuel tube connector to disconnect the fuel tube from the fuel delivery pipe.

NOTICE:

- ◆ Remove dirt or foreign objects on the fuel tube connector before this work.
- ◆ Do not allow any scratches or foreign objects on the parts when disconnecting as the fuel tube connector has the O-ring that seals the pipe.
- ◆ Perform this work by hand. Do not use any tools.
- ◆ Do not forcibly bend, twist or turn the nylon tube.
- ◆ Protect the connected part by covering it with a vinyl bag after disconnecting the fuel tube.
- ◆ If the fuel tube connector and pipe are stuck, push and pull them to release.

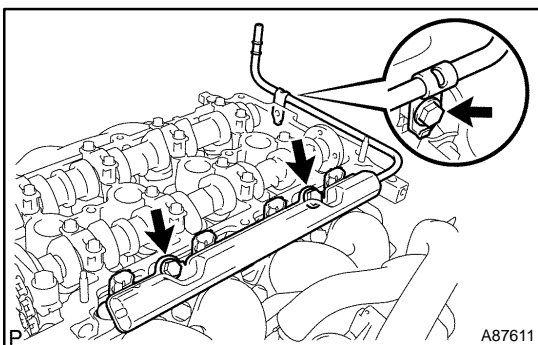
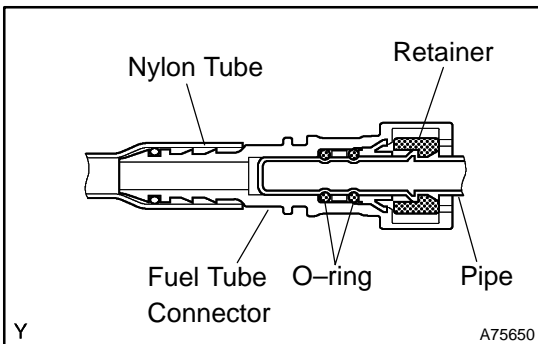

- (b) Remove the 3 bolts, then remove the fuel delivery pipe together with the 4 fuel injectors.

NOTICE:

Do not drop the fuel injectors when removing the fuel delivery pipe.

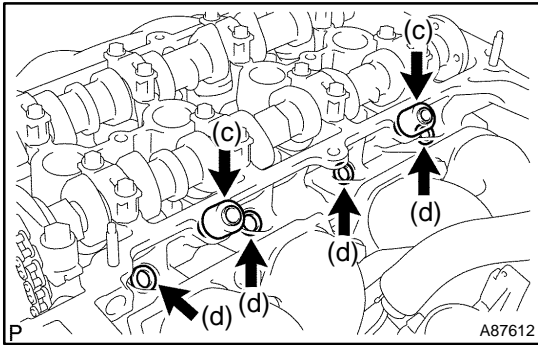

- (c) Remove the 2 delivery pipe No. 1 spacers from the cylinder head.
- (d) Remove the 4 insulators from the cylinder head.

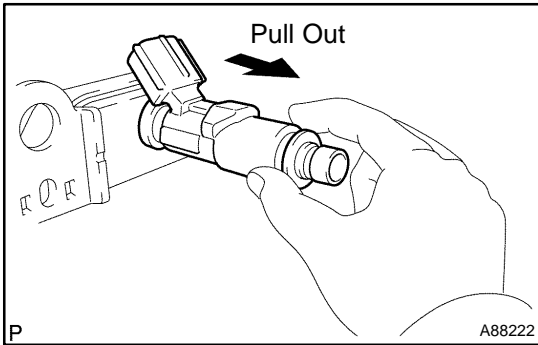

19. REMOVE FUEL INJECTOR ASSY

- (a) Pull out the 4 fuel injectors from the fuel delivery pipe.

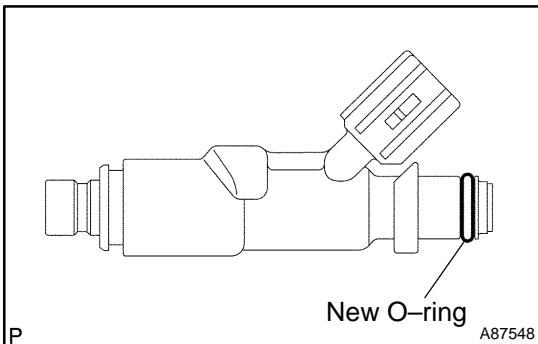

20. INSTALL FUEL INJECTOR ASSY

- (a) Apply a light coat of spindle oil or gasoline to a new O-ring, then install it to each fuel injector.

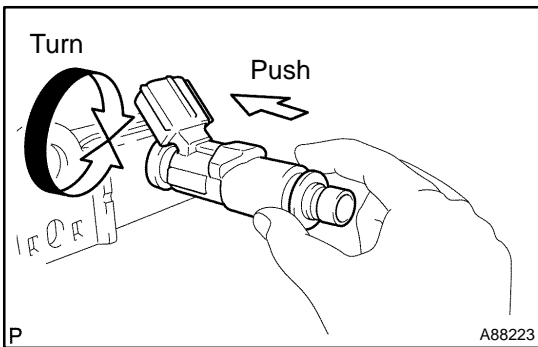

- (b) Apply a light coat of spindle oil or gasoline to the surface of the fuel delivery pipe which contacts the O-ring of the fuel injector.
- (c) Apply a light coat of spindle oil or gasoline to the O-ring again, then turning the fuel injector right and left to the fuel delivery pipe.

NOTICE:

Be careful that the O-ring is not cracked or jammed when installing.

- (d) Check that the fuel injector rotates smoothly. If the fuel injector does not rotate, replace the O-ring.

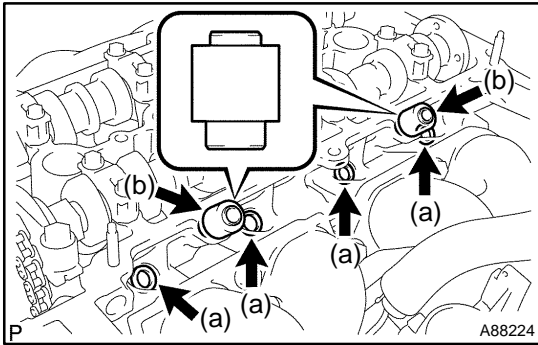

21. INSTALL FUEL DELIVERY PIPE SUB-ASSY

- (a) Install 4 new insulators to the cylinder head.
- (b) Install the 2 delivery pipe No. 1 spacers to the cylinder head.

NOTICE:

Be careful of the installation direction of the delivery pipe spacer.

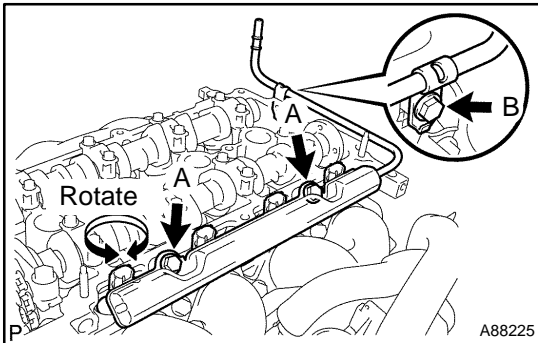

- (c) Install the fuel delivery pipe together with the 4 fuel injectors, then temporarily tighten the 3 bolts.

NOTICE:

Do not drop the fuel injectors when installing the fuel delivery pipe.

- (d) Check that the fuel injector rotates smoothly. If the fuel injector does not rotate, replace the O-ring.
- (e) Retighten the 3 bolts with the specified torque.

Torque:

19 N·m (194 kgf·cm, 14 ft·lbf) for bolt A

9.0 N·m (92 kgf·cm, 80 in·lbf) for bolt B

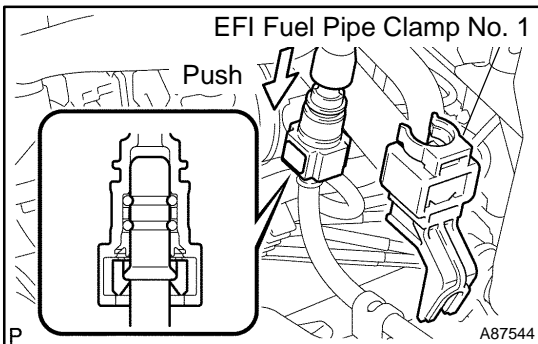

- (f) Connect the fuel tube to the fuel delivery pipe.
 - (1) Align the fuel tube connector with the pipe, then push in the fuel tube connector until the retainer makes a "click" sound to connect the fuel tube to the fuel delivery pipe.

NOTICE:

- ◆ Check that there are no scratches or foreign objects around the connected part of the fuel tube connector and pipe before this work.
- ◆ After connecting the fuel tube, check that the fuel tube connector and pipe are securely connected by pulling them.
- (2) Install the EFI fuel pipe clamp No. 1.

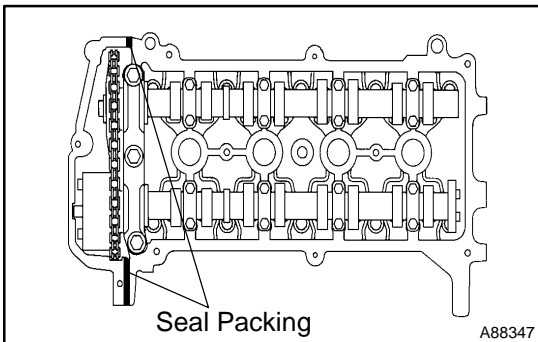

22. INSTALL CYLINDER HEAD COVER SUB-ASSY

- (a) Apply seal packing to the cylinder head as illustrated. **Seal packing: Part No. 08826-00080 or equivalent**

NOTICE:

- ◆ Remove any oil from the contact surface.
- ◆ Install the cylinder head cover within 3 minutes after applying seal packing.
- ◆ Do not start the engine within 2 hours of installation.

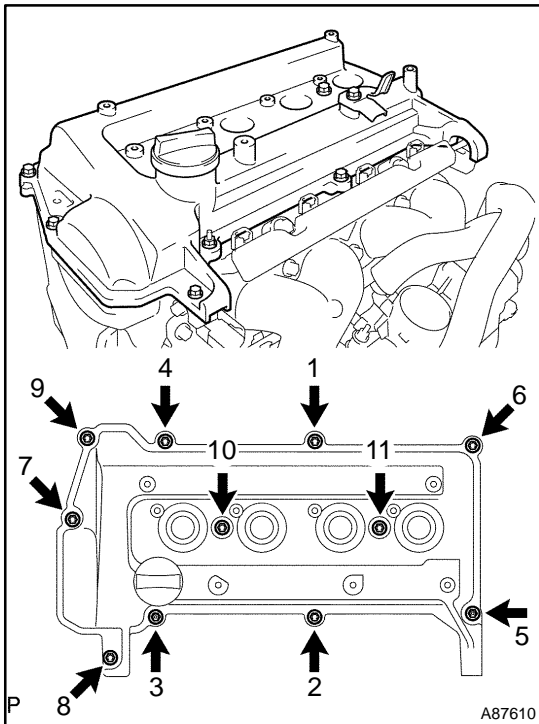

- (b) Tighten the 9 bolts, 2 seal washers and 2 nuts in the sequence shown in the illustration to install the cylinder head cover.
Torque: 10 N·m (102 kgf·cm, 7 ft·lbf)
- (c) Connect the ventilation hose No. 2 to the cylinder head cover.
- (d) Connect the ventilation hose to the ventilation valve.
- (e) Install the 4 ignition coils with the 4 bolts.
Torque: 9.0 N·m (92 kgf·cm, 80 in·lbf)
- (f) Install the engine wire and brake master cylinder reservoir cover with the 3 bolts.
Torque: 9.0 N·m (92 kgf·cm, 80 in·lbf)
- (g) Connect the 4 ignition coil connectors.
- (h) Connect the 4 fuel injector connectors.
- (i) Install the 2 wire harness clamps.

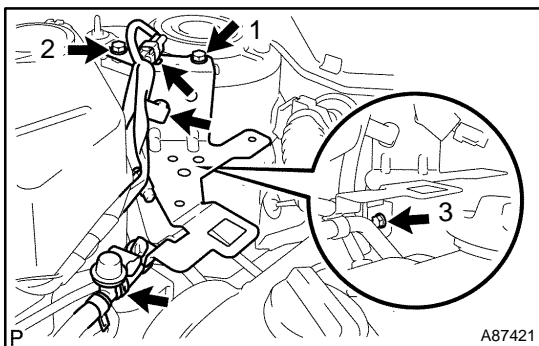

23. INSTALL RESERVOIR BRACKET

- (a) Temporarily install the reservoir bracket with the bolt 1.
- (b) Tighten the 3 bolts with the specified torque in the sequence shown in the illustration.
Torque: 8.5 N·m (87 kgf·cm, 75 in·lbf)
- (c) Install the connector clamp.
- (d) Install the wire harness clamp.
- (e) Install the fuel vapor feed hose No. 2 to the hose clamp.

24. INSTALL BRAKE MASTER CYLINDER RESERVOIR SUB-ASSY

Torque: 8.5 N·m (87 kgf·cm, 75 in·lbf)

25. INSTALL AIR CLEANER ASSY (See page 10-15)

26. INSTALL COWL TOP PANEL SUB-ASSY OUTER FRONT

Torque: 6.4 N·m (65 kgf·cm, 57 in·lbf)

27. INSTALL WINDSHIELD WIPER LINK ASSY (See page 66-14)

28. CONNECT ENGINE WIRE NO.3 (BATTERY NEGATIVE TERMINAL) (See page 19-2)

29. CHECK FOR FUEL LEAKS (See page 11-3)

30. CHECK FOR ENGINE OIL LEAKS

31. INSTALL COWL TOP VENTILATOR LOUVER RH

32. INSTALL COWL TOP VENTILATOR LOUVER LH

33. INSTALL HOOD TO COWL TOP SEAL

34. INSTALL FR WIPER ARM LH (See page 66-14)

35. INSTALL FR WIPER ARM RH (See page 66-14)

36. INSTALL WINDSHIELD WIPER ARM COVER

37. INSTALL REAR FLOOR BOARD NO.3

38. INSTALL DECK FLOOR BOX REAR

39. INSTALL REAR FLOOR BOARD NO.2

40. POWER WINDOW CONTROL SYSTEM INITIALIZE (See page 01-28)

FUEL TANK ASSY (1NZ-FXE) COMPONENTS

11121-01

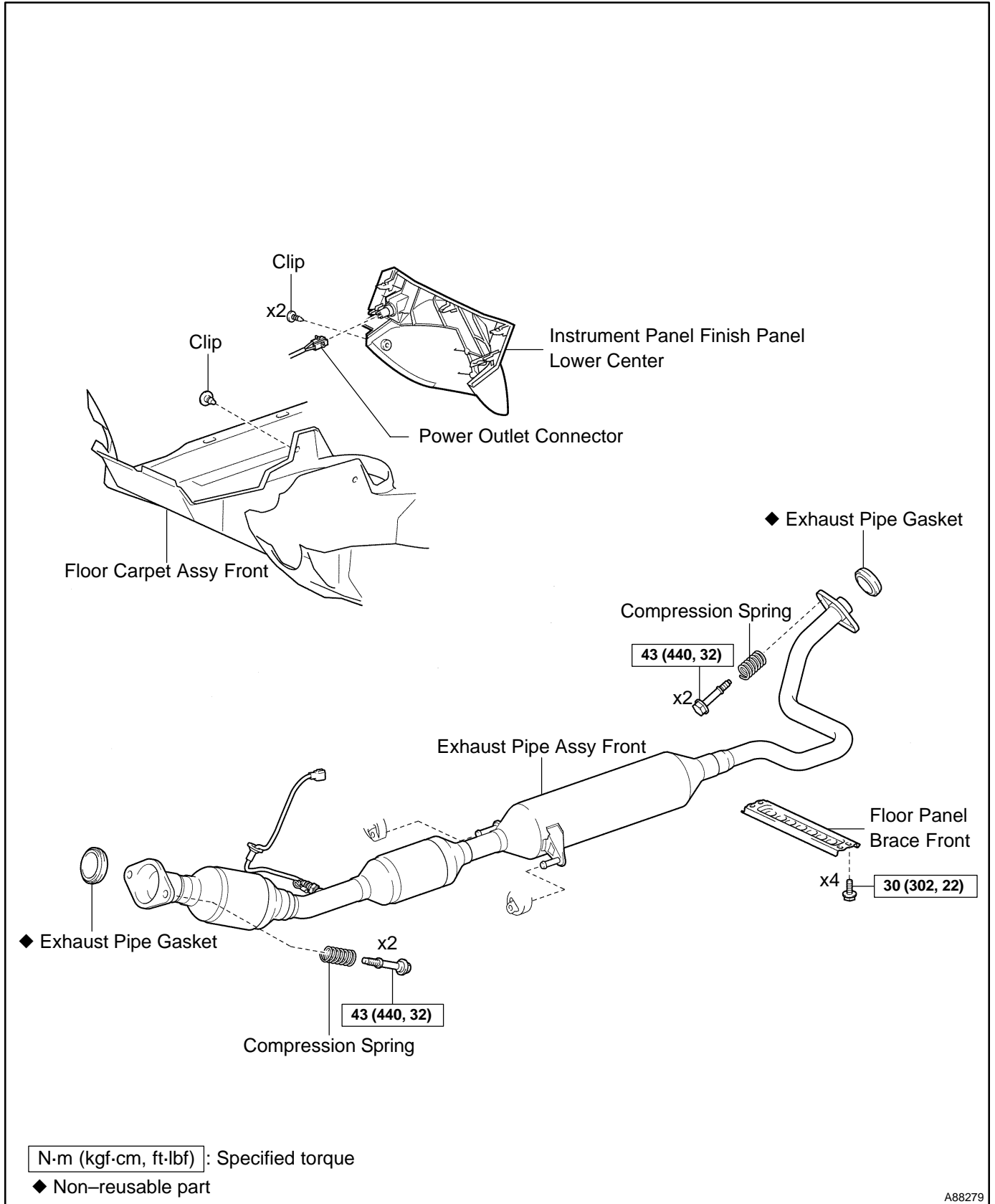

A88279

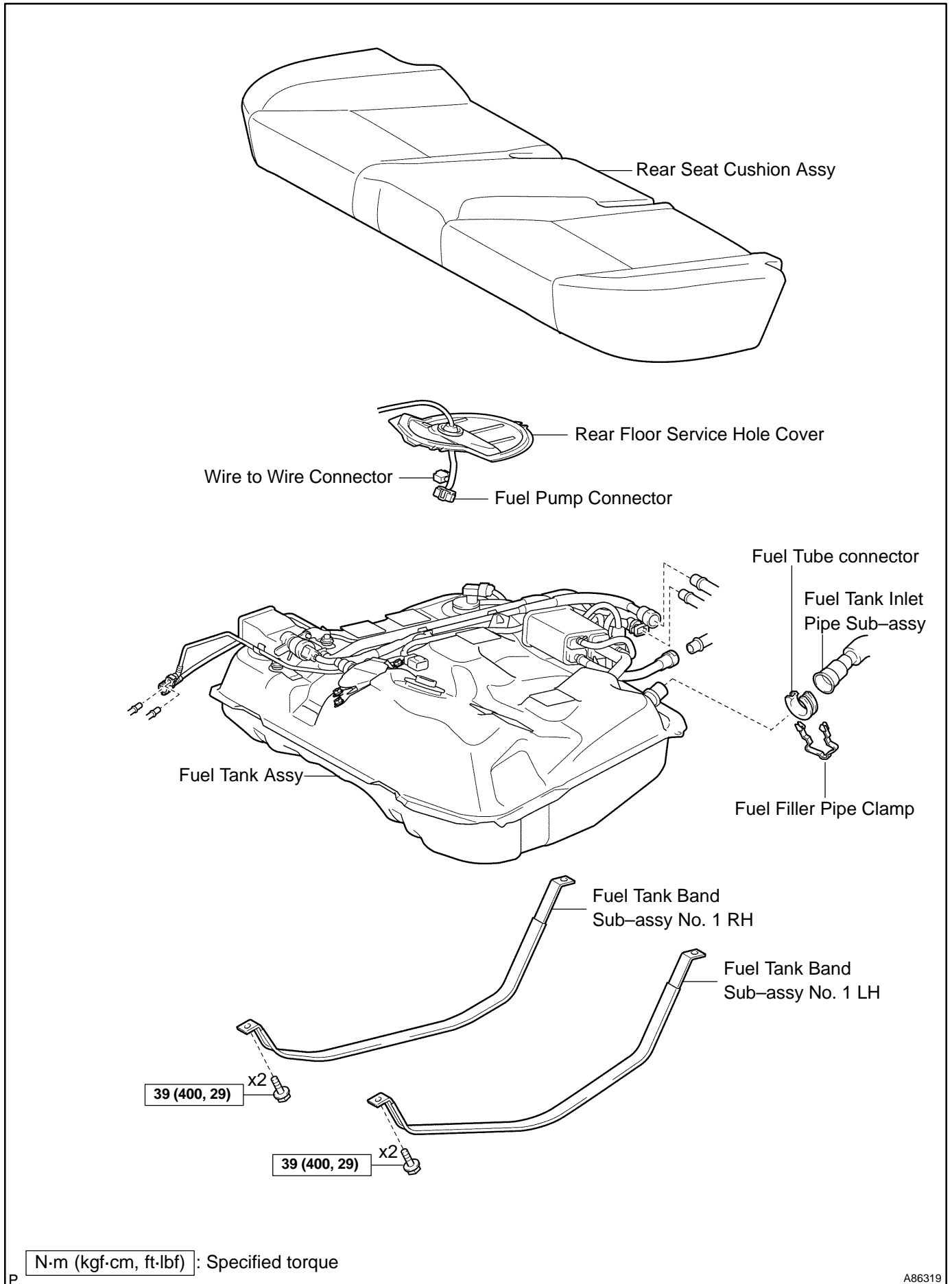

Removal & Installation and Disassembly & Reassembly

1. DISCHARGE FUEL SYSTEM PRESSURE (See page 11-3)
2. REMOVE REAR FLOOR BOARD NO.2 (See page 19-2)
3. REMOVE DECK FLOOR BOX REAR (See page 19-2)
4. REMOVE REAR FLOOR BOARD NO.3 (See page 19-2)
5. DISCONNECT ENGINE WIRE NO.3 (BATTERY NEGATIVE TERMINAL) (See page 19-2)
6. REMOVE INSTRUMENT PANEL FINISH PANEL LOWER CENTER (See page 71-13)
7. REMOVE FLOOR PANEL BRACE FRONT (See page 15-2)

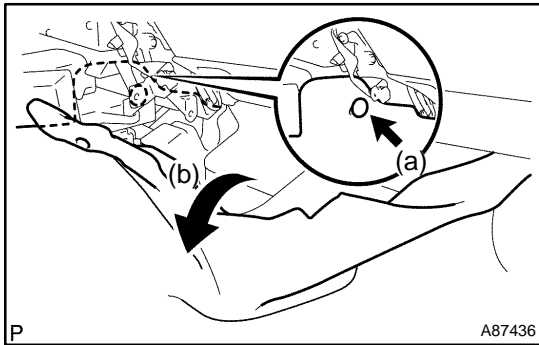

8. REMOVE EXHAUST PIPE ASSY FRONT

- (a) Using a clip remover, remove the clip.
- (b) Pull off the floor carpet front.

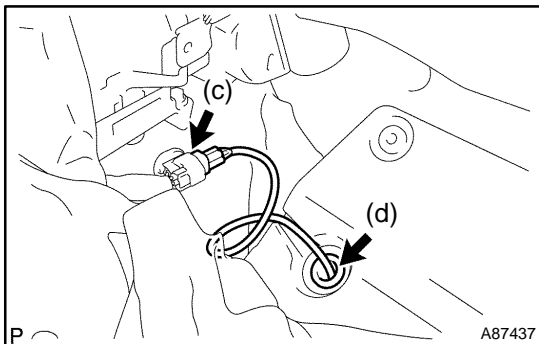

- (c) Disconnect the heated oxygen sensor connector.
- (d) Remove the grommet from the vehicle.

- (e) Remove the bolts and 4 compression springs.
- (f) Remove the exhaust pipe front from the 2 exhaust pipe supports.
- (g) Remove the 2 gaskets from the exhaust manifold and exhaust pipe front.

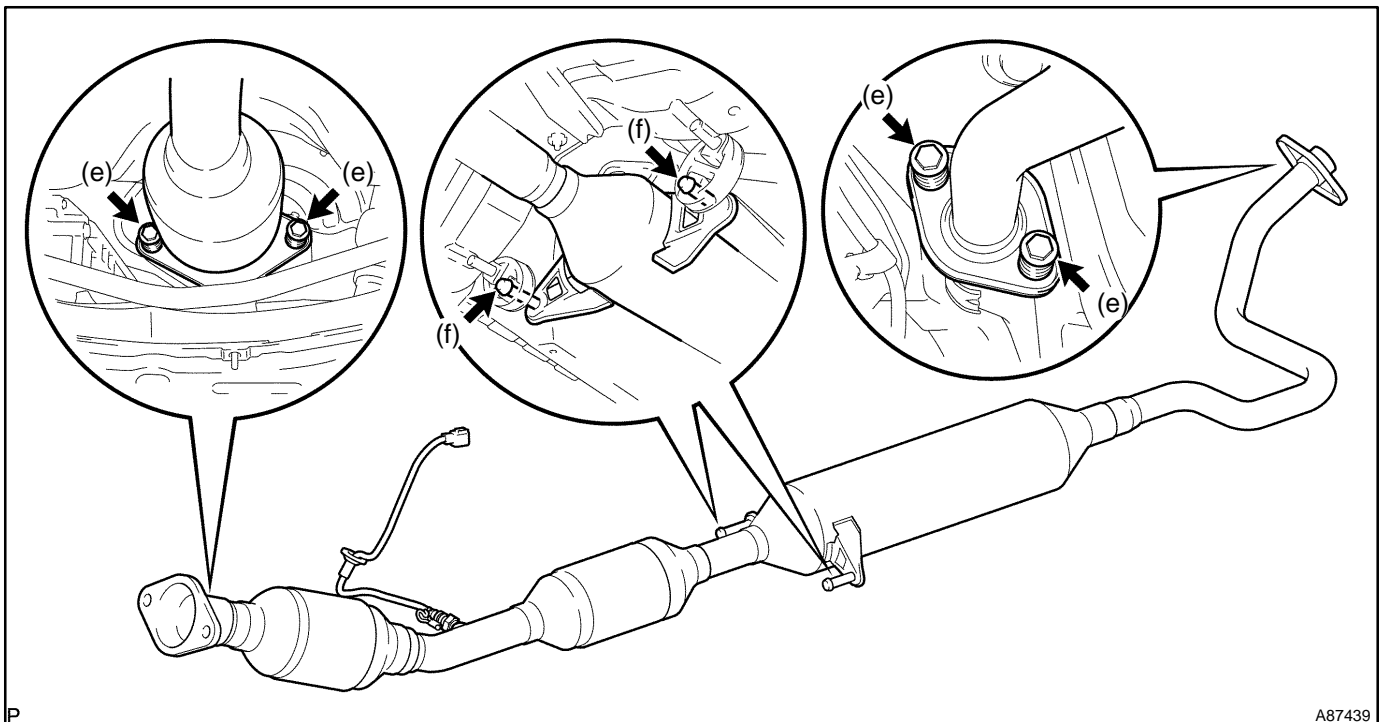

9. REMOVE REAR SEAT CUSHION ASSY (See page 72-9)

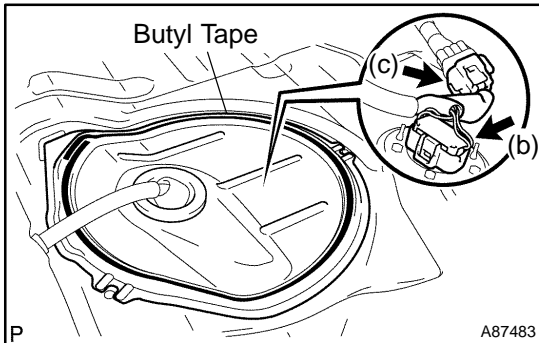

10. REMOVE REAR FLOOR SERVICE HOLE COVER
- (a) Remove the butyl tape, then remove the rear floor service hole cover.
 - (b) Disconnect the fuel pump connector.
 - (c) Disconnect the wire to wire connector.

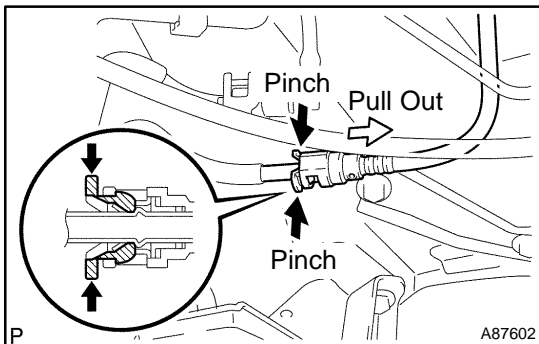

11. REMOVE FUEL TANK ASSY
- (a) Disconnect the fuel tank to canister tube.
 - (1) Pinch the retainer of the fuel tube connector, then pull out the fuel tube connector to disconnect the fuel tank to canister tube from the pipe.

NOTICE:

- ◆ Remove dirt or foreign objects on the fuel tube connector before this work.
- ◆ Do not allow any scratches or foreign objects on the parts when disconnecting as the fuel tube connector has the O-ring that seals the pipe.
- ◆ Perform this work by hand. Do not use any tools.
- ◆ Do not forcibly bend, twist or turn the nylon tube.
- ◆ Protect the connected part by covering it with a vinyl bag after disconnecting the fuel tank to canister tube.
- ◆ If the fuel tube connector and pipe are stuck, push and pull them to release.

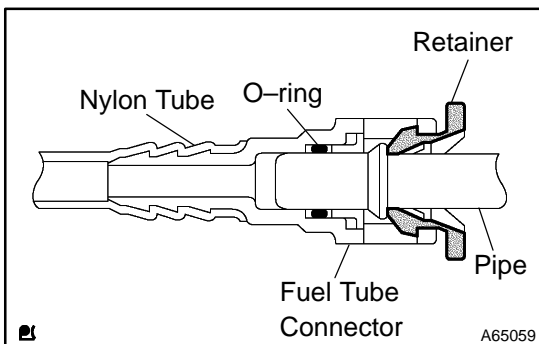

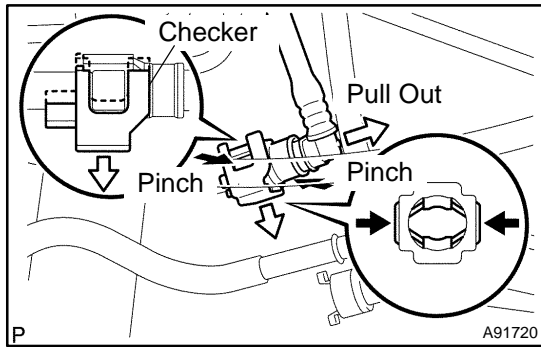

- (b) Disconnect the fuel tank main tube no. 2.
- (1) Remove the checker of the fuel tube connector from the pipe.
 - (2) Pinch the retainer of the fuel tube connector, then pull out the fuel tube connector to disconnect the fuel tank main tube No. 2 from the pipe.

NOTICE:

- ◆ Remove dirt or foreign objects on the fuel tube connector before this work.
- ◆ Do not allow any scratches or foreign objects on the parts when disconnecting as the fuel tube connector has the O-ring that seals the pipe.
- ◆ Perform this work by hand. Do not use any tools.
- ◆ Do not forcibly bend, twist or turn the nylon tube.
- ◆ Protect the connected part by covering it with a vinyl bag after disconnecting the fuel tank main tube No. 2.
- ◆ If the fuel tube connector and pipe are stuck, push and pull them to release.

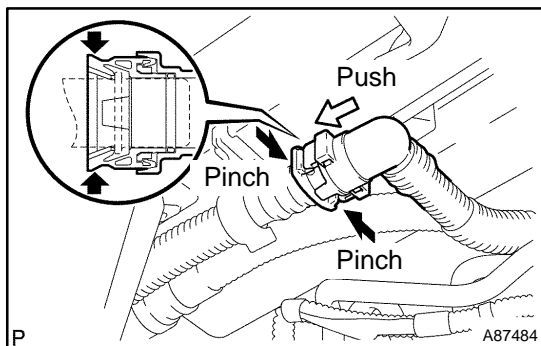
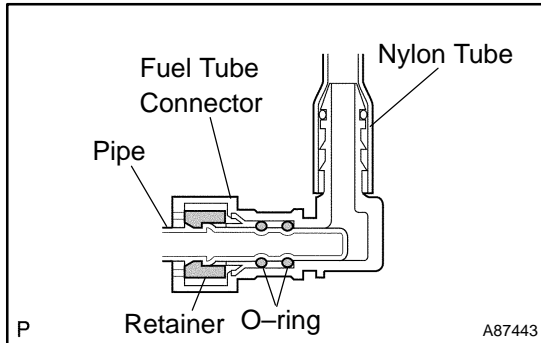

- (c) Disconnect the fuel tank vent hose.
- (1) Pinch the retainer and pull out the fuel tank vent connector No. 2 with the fuel tank vent connector No. 2 pushed to the pipe side to disconnect the fuel tank vent hose from the charcoal canister filter.

NOTICE:

- ◆ Remove dirt or foreign objects on the fuel tank vent connector No. 2 before this work.
- ◆ Do not allow any scratches or foreign objects on the parts when disconnecting as the fuel tank vent connector No. 2 has the O-ring that seals the pipe.
- ◆ Perform this work by hand. Do not use any tools.
- ◆ Do not forcibly bend, twist or turn the nylon tube.
- ◆ Protect the connected part by covering it with a vinyl bag after disconnecting the fuel tank vent hose.
- ◆ If the fuel tank vent connector No. 2 and pipe are stuck, push and pull them to release.

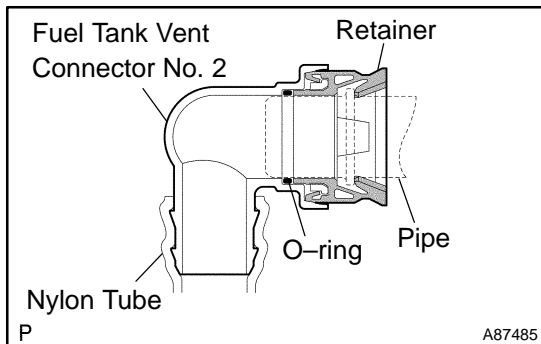

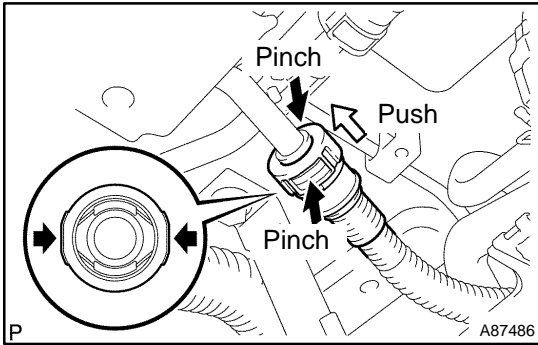

- (d) Disconnect the fuel suction tube.
- (1) Pinch the retainer and pull out the quick connector with the quick connector pushed to the pipe side to disconnect the fuel suction tube from the fuel tank to filler pipe.

NOTICE:

- ◆ Remove dirt or foreign objects on the quick connector before this work.
- ◆ Do not allow any scratches or foreign objects on the parts when disconnecting as the fuel tank vent connector No. 2 has the O-ring that seals the pipe.
- ◆ Perform this work by hand. Do not use any tools.
- ◆ Do not forcibly bend, twist or turn the nylon tube.
- ◆ Protect the connected part by covering it with a vinyl bag after disconnecting the fuel suction tube.
- ◆ If the quick connector and pipe are stuck, push and pull them to release.

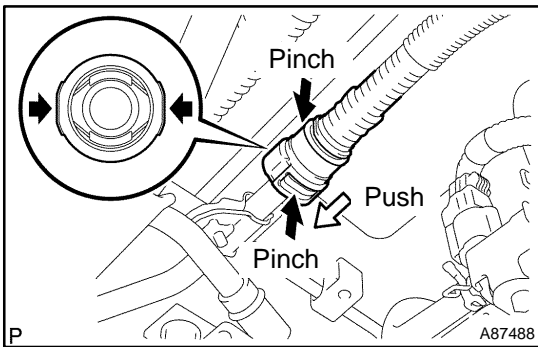
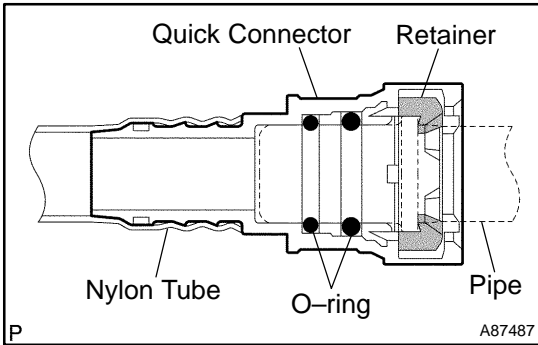

- (e) Disconnect the charcoal canister tube No. 1.
- (1) Pinch the retainer and pull out the quick connector with the quick connector pushed to the pipe side to disconnect the charcoal canister tube No. 1 from the fuel tank to filler pipe.

NOTICE:

- ◆ Remove dirt or foreign objects on the quick connector before this work.
- ◆ Do not allow any scratches or foreign objects on the parts when disconnecting as the fuel tank vent connector No. 2 has the O-ring that seals the pipe.
- ◆ Perform this work by hand. Do not use any tools.
- ◆ Do not forcibly bend, twist or turn the nylon tube.
- ◆ Protect the connected part by covering it with a vinyl bag after disconnecting the charcoal canister tube No. 1.
- ◆ If the quick connector and pipe are stuck, push and pull them to release.

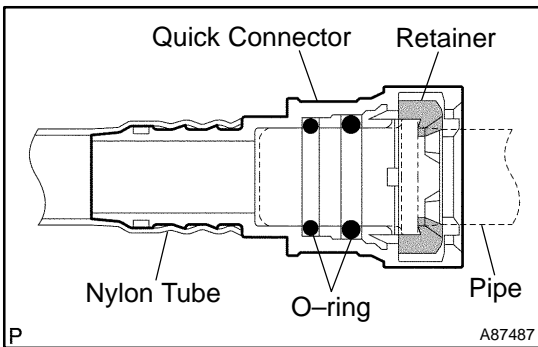

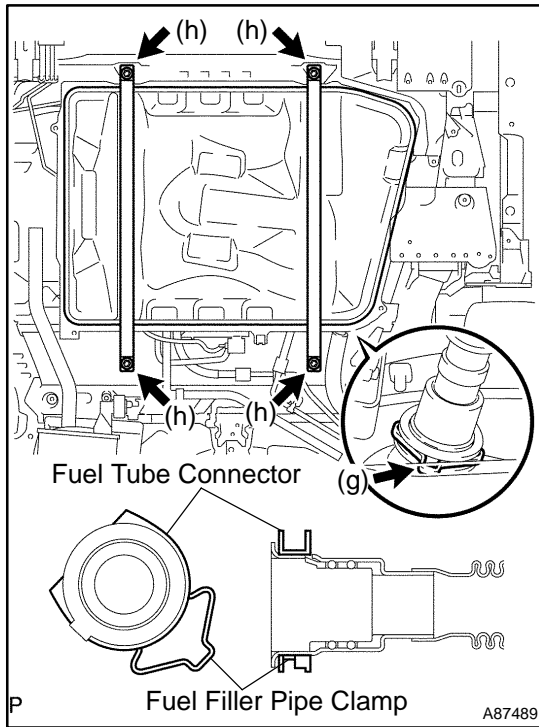

- (f) Set a transmission jack to the fuel tank.
- (g) Remove fuel filler pipe clamp and fuel tube connector from the fuel tank inlet pipe.
- (h) Remove the 4 bolts, then remove the fuel tank bands No. 1 RH and LH.
- (i) Operate the transmission jack, then disconnect the fuel tank inlet pipe.
- (j) Operate the transmission jack, then remove the fuel tank.

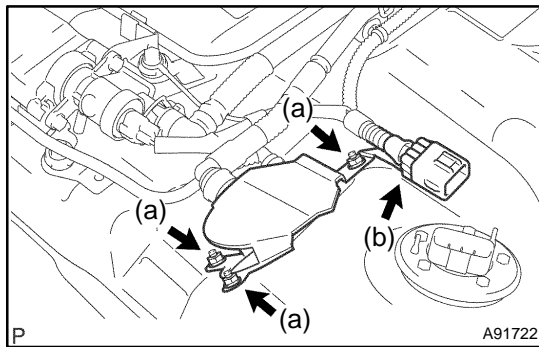

- 12. REMOVE FUEL TANK MAIN TUBE SUB-ASSY NO.2**
- (a) Remove the 3 nuts, then remove the fuel tank bracket RR.
 - (b) Remove the wire to wire connector from the fuel tank bracket RR.

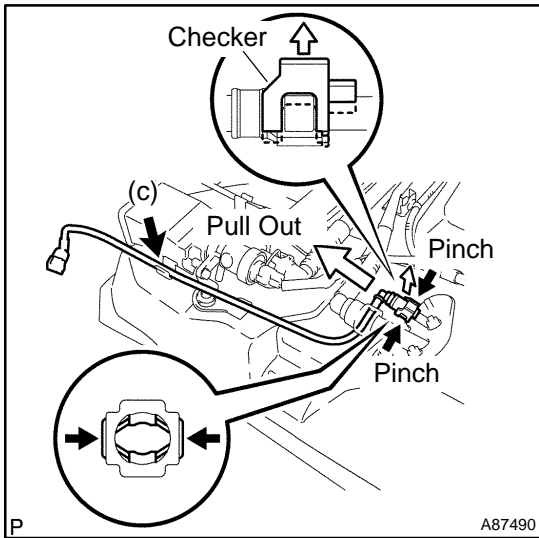

- (c) Remove the tube of the fuel tank main tube No. 2 from the clamp.
- (d) Remove the checker of the fuel tube connector from the pipe.
- (e) Pinch the retainer of the fuel tube connector, then pull out the fuel tube connector to disconnect the fuel tank main tube No. 2 from the pipe.

NOTICE:

- ◆ Remove dirt or foreign objects on the fuel tube connector before this work.
- ◆ Do not allow any scratches or foreign objects on the parts when disconnecting as the fuel tube connector has the O-ring that seals the pipe.
- ◆ Perform this work by hand. Do not use any tools.
- ◆ Do not forcibly bend, twist or turn the nylon tube.
- ◆ Protect the connected part by covering it with a vinyl bag after disconnecting the fuel tank main tube No. 2.
- ◆ If the fuel tube connector and pipe are stuck, push and pull them to release.

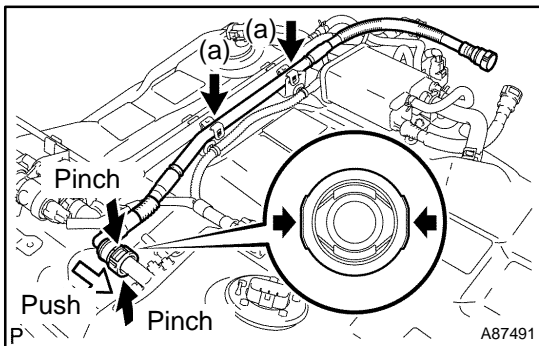
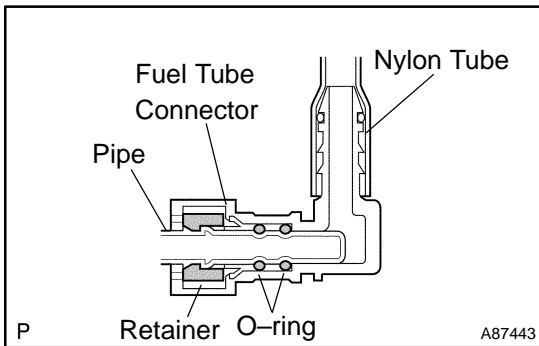

13. REMOVE FUEL SUCTION TUBE SUB-ASSY

- (a) Remove the tube of the fuel tank suction tube from the 2 fuel tube with grommet clamps No. 1.
- (b) Pinch the retainer and pull out the quick connector with the quick connector pushed to the pipe side to disconnect the fuel suction tube from the pipe.

NOTICE:

- ◆ Remove dirt or foreign objects on the quick connector before this work.
- ◆ Do not allow any scratches or foreign objects on the parts when disconnecting as the fuel tank vent connector No. 2 has the O-ring that seals the pipe.
- ◆ Perform this work by hand. Do not use any tools.
- ◆ Do not forcibly bend, twist or turn the nylon tube.
- ◆ Protect the connected part by covering it with a vinyl bag after disconnecting the fuel suction tube.
- ◆ If the quick connector and pipe are stuck, push and pull them to release.

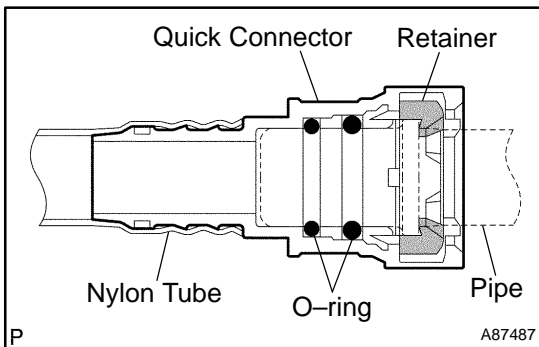

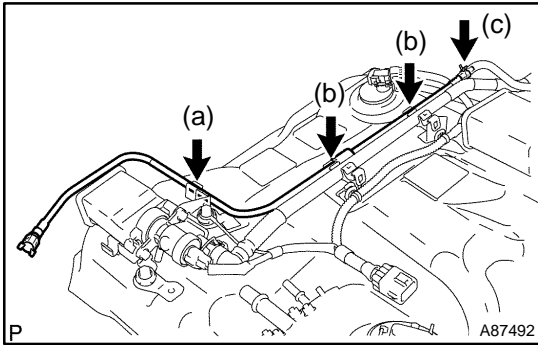
**14. REMOVE FUEL TANK TO CANISTER TUBE**

- (a) Remove the tube of the fuel tank to canister tube from the clamp.
- (b) Remove the tube of the fuel tank to canister tube from the 2 fuel tube with grommet camps No. 1.
- (c) Remove the fuel tank to canister tube from the charcoal canister.

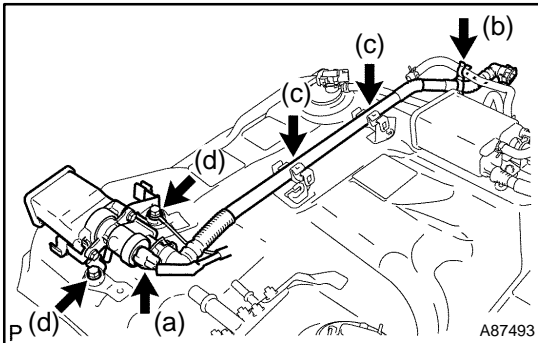
**15. REMOVE TRAP W/OUTLET VALVE CANISTER ASSY**

- (a) Disconnect the VSV connector.
- (b) Remove the clamp from the fuel tank vent hose and charcoal canister hose.
- (c) Remove the tube of the fuel tank vent hose from the 2 fuel tube with grommet clamps No.1.
- (d) Remove the 2 bolts, then remove the trap with outlet valve canister and ground terminal of the fuel tank wire.

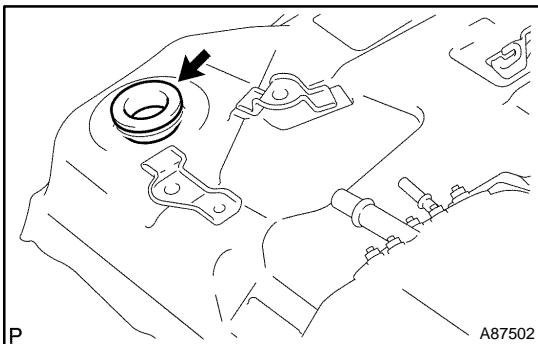

- (e) Remove the gasket from the fuel tank.

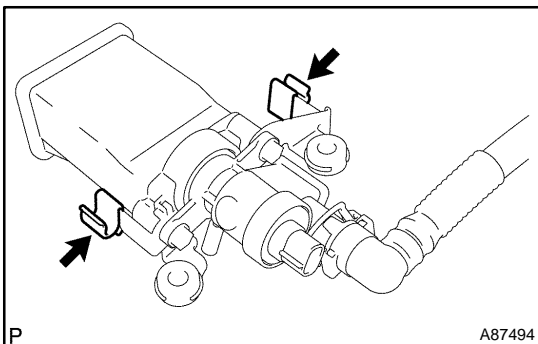

- (f) Remove the 2 clamps from the trap with outlet valve canister.

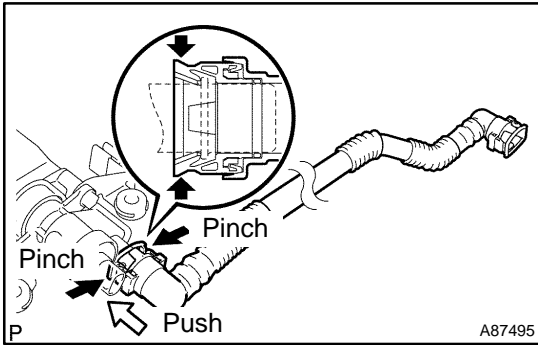

16. REMOVE FUEL TANK VENT HOSE

- (a) Pinch the retainer and pull out the fuel tank vent connector No. 2 with the fuel tank vent connector No. 2 pushed to the pipe side to disconnect the fuel tank vent hose from the trap with outlet valve canister.

NOTICE:

- ◆ Remove dirt or foreign objects on the fuel tank vent connector No. 2 before this work.
- ◆ Do not allow any scratches or foreign objects on the parts when disconnecting as the fuel tank vent connector No. 2 has the O-ring that seals the pipe.
- ◆ Perform this work by hand. Do not use any tools.
- ◆ Do not forcibly bend, twist or turn the nylon tube.
- ◆ Protect the connected part by covering it with a vinyl bag after disconnecting the fuel tank vent hose.
- ◆ If the fuel tank vent connector No. 2 and pipe are stuck, push and pull them to release.

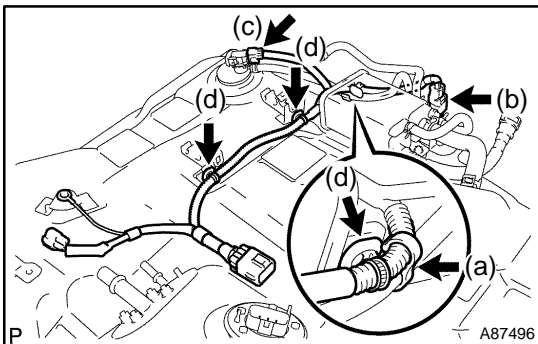
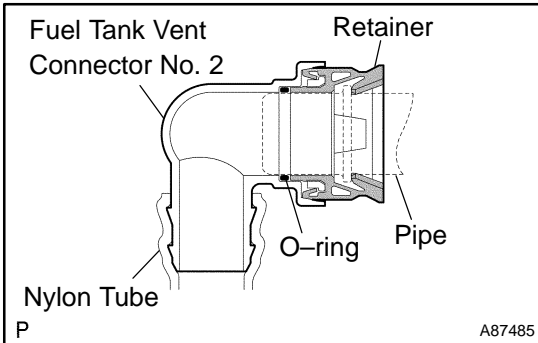

17. REMOVE FUEL TANK WIRE

- (a) Remove the clamp.
- (b) Disconnect the VSV connector.
- (c) Disconnect the vapor pressure sensor connector.
- (d) Remove the 3 wire harness clamps.

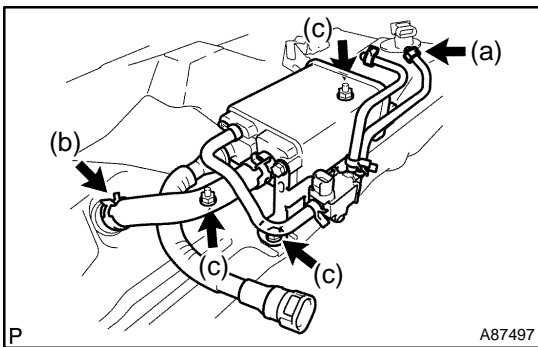

18. REMOVE CHARCOAL CANISTER ASSY

- (a) Disconnect the charcoal canister hose from the fuel tank retainer.
- (b) Disconnect the charcoal canister outlet hose No. 1 from the fuel tank.
- (c) Remove the bolt and 2 nuts, then remove the charcoal canister.

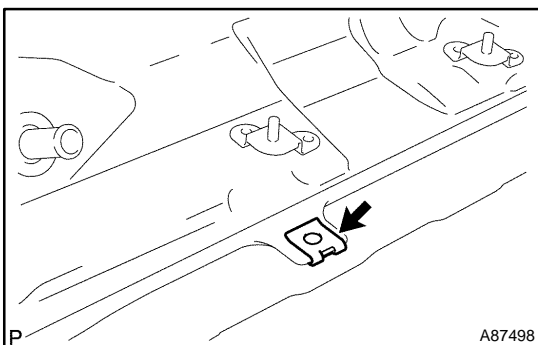

- (d) Remove the spring nut from the fuel tank.

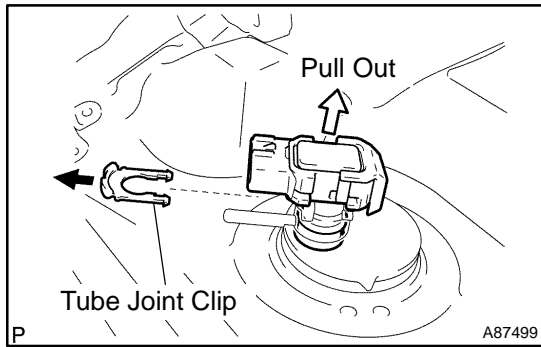

19. REMOVE VAPOR PRESSURE SENSOR ASSY

- (a) Remove the tube joint clip, then pull out the vapor pressure sensor from the fuel tank retainer.

NOTICE:

- ◆ Remove dirt or foreign objects on vapor pressure sensor before this work.
- ◆ Do not allow any scratches or foreign objects on the parts when disconnecting as the vapor pressure sensor has the O-ring that seals the plug.
- ◆ Perform this work by hand. Do not use any tools.

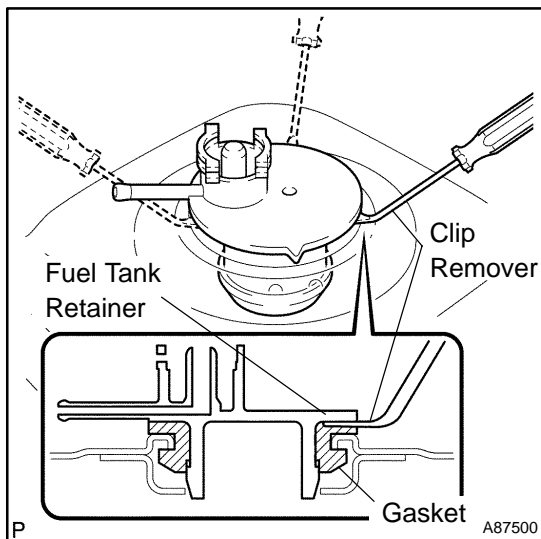
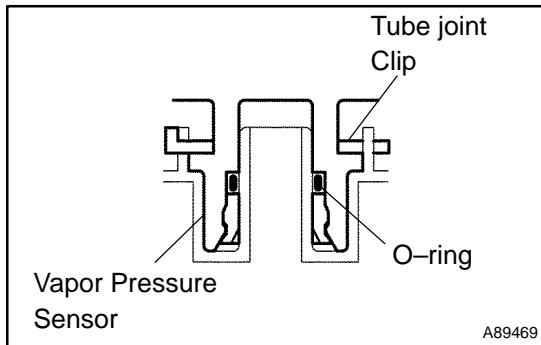

20. REMOVE FUEL TANK RETAINER LH

- (a) Insert a clip remover between the fuel tank retainer and gasket, then remove the fuel tank retainer by lifting it little by little.

NOTICE:

- ◆ The fuel tank retainer is made of resin and easily damaged if removed or installed forcibly. Handle the part correctly to ensure the sealing.
- ◆ After removing, check that the contact surface of the fuel tank retainer on the fuel tank is not damaged.

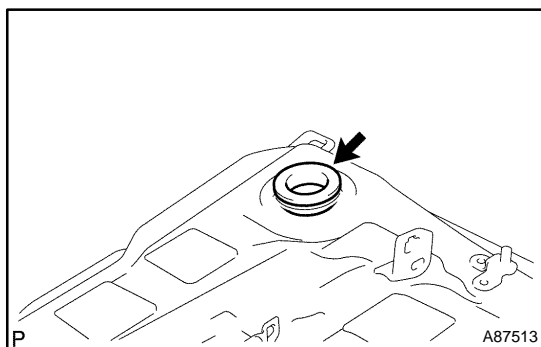

- (b) Remove the gasket from the fuel tank.

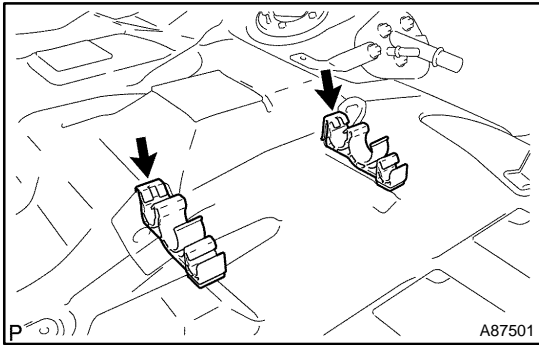

- 21. REMOVE FUEL TUBE W/GROMMET CLAMP NO.1**
 (a) Remove the 2 fuel tube with grommet clamps No. 1 from the fuel tank.

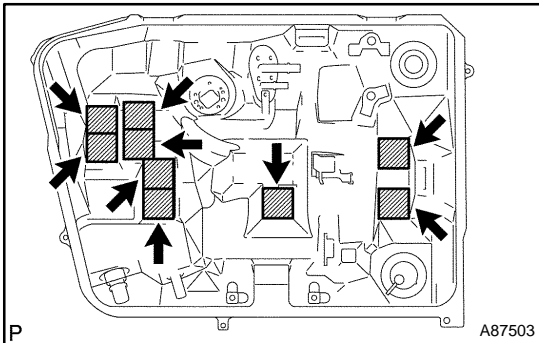

- 22. REMOVE FUEL TANK CUSHION NO.1**
 (a) Remove the 9 fuel tank cushions No. 1 from the fuel tank.

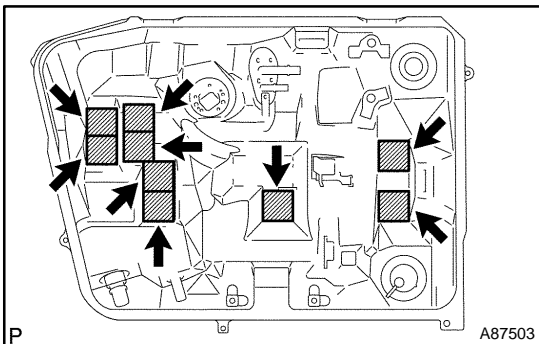

- 23. INSTALL FUEL TANK CUSHION NO.1**
 (a) Install new 9 fuel tank cushions to the fuel tank.

24. INSTALL FUEL TUBE W/GROMMET CLAMP NO.1

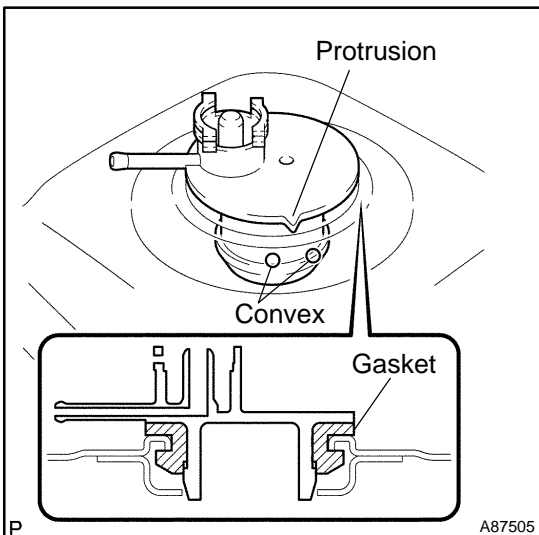

- 25. INSTALL FUEL TANK RETAINER LH**
 (a) Install a new gasket to the fuel tank.
 (b) While being careful that the gasket does not drop in the fuel tank, insert the fuel tank retainer to the fuel tank so the protrusion of the fuel tank retainer is in the middle of the 2 convexes of the fuel tank.

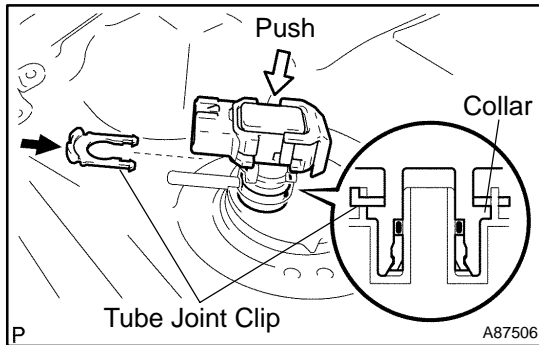
**26. INSTALL VAPOR PRESSURE SENSOR ASSY**

- (a) Push the vapor pressure sensor to the plug of the fuel tank retainer, then install the tube joint clip.

NOTICE:

- ◆ Check that there are no scratches or foreign objects around the connected part of the vapor pressure sensor and fuel tank retainer before this work.
- ◆ Check that the vapor pressure sensor is securely inserted to the end.
- ◆ Check that the tube joint clip is on the collar of the vapor pressure sensor.
- ◆ After installing the tube joint clip, check that the vapor pressure sensor cannot be pulled out.

27. INSTALL CHARCOAL CANISTER ASSY

Torque: 6.0 N·m (61 kgf·cm, 53 in.·lbf)

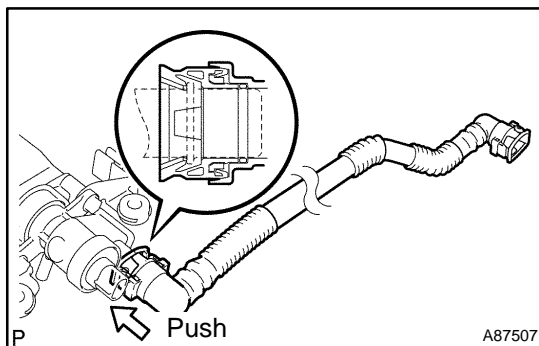
28. INSTALL FUEL TANK WIRE**29. INSTALL FUEL TANK VENT HOSE**

- (a) Align the fuel tank vent connector No. 2 with the pipe, then push in the fuel tank vent connector No. 2 until the retainer makes a "click" sound to install the fuel tank vent hose to the trap with outlet valve canister.

NOTICE:

- ◆ Check that there are no scratches or foreign objects around the connected part of the fuel tank vent connector No. 2 and pipe before this work.
- ◆ After connecting the fuel tank vent hose, check that the fuel tank vent hose is securely connected by pulling the fuel tank vent connector No. 2.

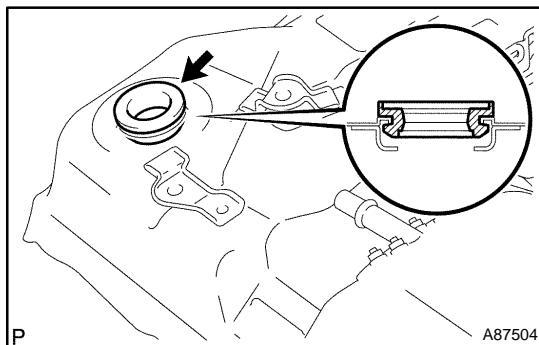
**30. INSTALL TRAP W/OUTLET VALVE CANISTER ASSY**

- (a) Install a new gasket to the fuel tank.
 (b) While being careful that the gasket does not drop in the fuel tank, insert the trap with outlet valve canister to the fuel tank.
 (c) Install the trap with outlet valve canister and ground terminal of the fuel tank wire with the 2 bolts.
Torque: 6.0 N·m (61 kgf·cm, 53 in.·lbf)
 (d) Install the tube of the fuel tank vent hose to the 2 fuel tube with grommet clamps. No. 1.
 (e) Install the clamp to the fuel tank vent hose and charcoal canister hose.
 (f) Connect the VSV connector.

31. INSTALL FUEL TANK TO CANISTER TUBE

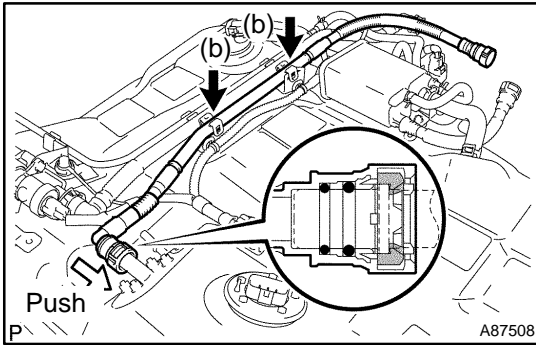
**32. INSTALL FUEL SUCTION TUBE SUB-ASSY**

- (a) Align the quick connector with the pipe, then push in the quick connector until the retainer makes a "click" sound to install the fuel suction tube to the pipe.

NOTICE:

- ◆ Check that there are no scratches or foreign objects around the connected part of the quick connector and pipe before this work.
- ◆ After connecting the fuel suction tube, check that the fuel suction tube is securely connected by pulling the quick connector.

- (b) Install the tube of the fuel suction tube to the 2 fuel tube with grommet clamps No. 1.

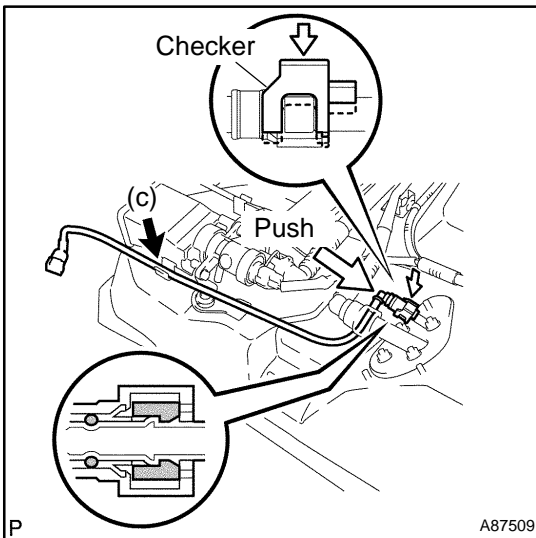
**33. INSTALL FUEL TANK MAIN TUBE SUB-ASSY NO.2**

- (a) Align the fuel tube connector with the pipe, then push in the fuel tube connector until the retainer makes a "click" sound to install the fuel tank main tube No. 2 to the pipe.

NOTICE:

- ◆ Check that there are no scratches or foreign objects around the connected part of the fuel tube connector.
- ◆ After connecting the fuel tank main tube No. 2, check that the fuel tank main tube No. 2 is securely connected by pulling the fuel tube connector.

- (b) Install the checker to the pipe.
 (c) Install the tube of the fuel tank main tube No. 2 to the clamp.
 (d) Install the connector clamp to the fuel tank bracket RR.
 (e) Install the fuel tank bracket RR with the 3 nuts.

Torque: 6.0 N·m (61 kgf·cm, 53 in.·lbf)

34. INSTALL FUEL TANK ASSY

- (a) Set the fuel tank to a transmission jack.
 (b) Operate the transmission jack, then install the fuel tank to the vehicle.
 (c) Operate the transmission jack, then connect the fuel tank inlet pipe.
 (d) Install the fuel tank bands No. 1 RH and LH with the 4 bolts.

Torque: 39 N·m (400 kgf·cm, 29 ft·lbf)

- (e) Install the fuel tube connector and fuel filler pipe clamp to the fuel tank inlet pipe.

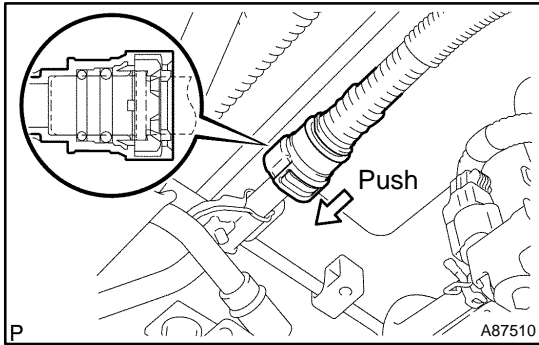

- (f) Connect the charcoal canister tube No. 1.
- (1) Align the quick connector with the pipe, then push in the quick connector until the retainer makes a "click" sound to connect the charcoal canister tube No. 1 to the fuel tank to filler pipe.

NOTICE:

- ◆ Check that there are no scratches or foreign objects around the connected part of the quick connector and pipe before this work.
- ◆ After connecting the charcoal canister tube No. 1, check that the charcoal canister tube No. 1 is securely connected by pulling the quick connector.

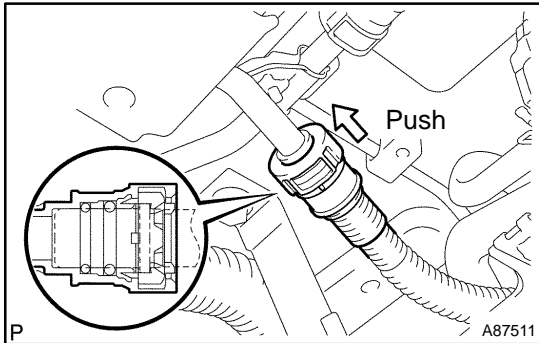

- (g) Connect the fuel suction tube.
- (1) Align the quick connector with the pipe, then push in the quick connector until the retainer makes a "click" sound to connect the fuel suction tube to the fuel tank to filler pipe.

NOTICE:

- ◆ Check that there are no scratches or foreign objects around the connected part of the quick connector and pipe before this work.
- ◆ After connecting the fuel suction tube, check that the fuel suction tube is securely connected by pulling the quick connector.

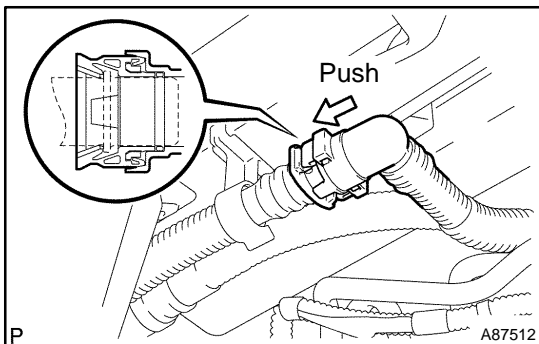

- (h) Connect the fuel tank vent hose.
- (1) Align the fuel tank vent connector No. 2 with the pipe, then push in the fuel tank vent connector No. 2 until the retainer makes a "click" sound to connect the fuel tank vent hose to the charcoal canister filter.

NOTICE:

- ◆ Check that there are no scratches or foreign objects around the connected part of the fuel tank vent connector No. 2 and pipe before this work.
- ◆ After connecting the fuel tank vent hose, check that the fuel tank vent hose is securely connected by pulling the quick connector.

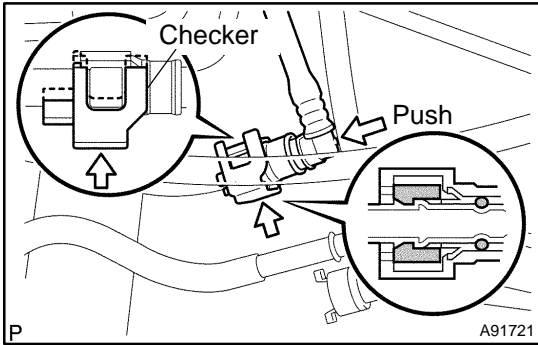

- (i) Connect the fuel tank main tube No. 2.
 - (1) Align the fuel tube connector with the pipe, then push in the fuel tube connector until the retainer makes a "click" sound to connect the fuel tank main tube No. 2 to the pipe.

NOTICE:

- ◆ Check that there are no scratches or foreign objects around the connected part of the fuel tube connector and pipe before this work.
- ◆ After connecting the fuel tank main tube No. 2, check that the fuel tank main tube No. 2 is securely connected by pulling the quick connector.

- (j) Install the checker to the pipe.

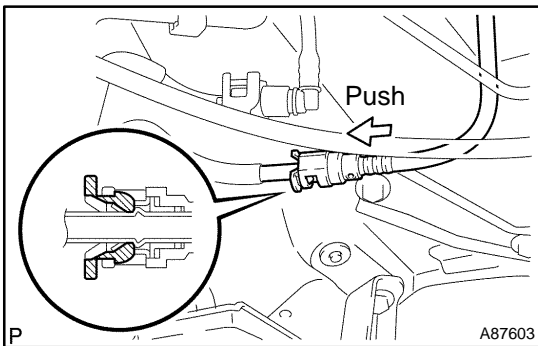

- (k) Connect the fuel tank to canister tube.
 - (1) Align the fuel tube connector with the pipe, then push in the fuel tube connector until the retainer makes a "click" sound to connect the fuel tank to canister tube to the pipe.

NOTICE:

- ◆ Check that there are no scratches or foreign objects around the connected part of the fuel tube connector and pipe before this work.
- ◆ After connecting the fuel tank to canister tube, check that the fuel tank to canister tube is securely connected by pulling the quick connector.

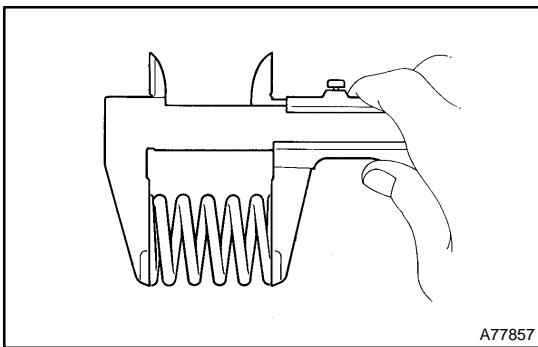

35. INSTALL EXHAUST PIPE ASSY FRONT

- (a) Inspect the free length.
 - (1) Using vernier calipers, measure the free length of the compression spring.

Minimum:

40.5mm (1.594 in.) for Exhaust pipe front x Exhaust manifold

38.5mm (1.516 in.) for Exhaust pipe front x Exhaust pipe tail

If the free length is less than minimum, replace the compression spring.

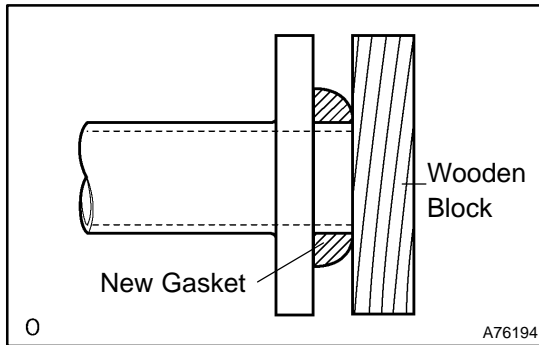

- (b) Using a wooden block and plastic-faced hammer, tap in a new gasket until it is flush with the exhaust manifold.

NOTICE:

- ◆ Be careful of the installation direction of a new gasket.
- ◆ Do not reuse the removed gasket.
- ◆ Never push a new gasket into the exhaust manifold by installing the exhaust pipe front to the exhaust manifold.

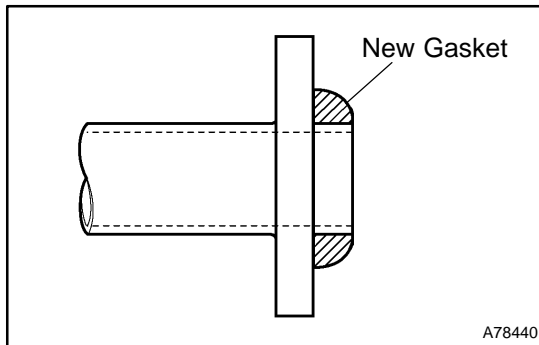

- (c) Install a new gasket to the exhaust pipe front.

NOTICE:

Be careful of the installation direction of a new gasket.

- (d) Install the exhaust pipe front to the 2 exhaust pipe supports.
- (e) Tighten the 4 compression springs and 4 bolts.
Torque: 43 N·m (440 kgf·cm, 32 ft·lbf)
- (f) Install the grommet of the heated oxygen sensor to the vehicle.
- (g) Connect the heated oxygen sensor connector.
- (h) Install the floor carpet front with the clip.

36. **CONNECT ENGINE WIRE NO.3 (BATTERY NEGATIVE TERMINAL) (See page 19-2)**

37. **CHECK FOR FUEL LEAKS (See page 11-7)**

38. **CHECK FOR EXHAUST GAS LEAKS**

39. **INSTALL FLOOR PANEL BRACE FRONT (See page 15-2)**

40. **INSTALL INSTRUMENT PANEL FINISH PANEL LOWER CENTER**

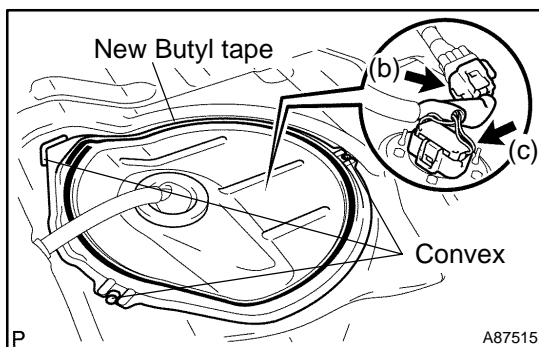

41. **INSTALL REAR FLOOR SERVICE HOLE COVER**

- (a) Attach new butyl tape to the rear floor service hole cover.
- (b) Connect the wire to wire connector.
- (c) Connect the fuel pump connector.
- (d) Install the rear floor service hole cover while adjusting it to the 3 convexes of the floor panel.

NOTICE:

Be careful that the rear floor service hole cover does not mount on the convex of the floor panel when installing.

42. **INSTALL REAR SEAT CUSHION ASSY (See page 72-9)**

43. **INSTALL REAR FLOOR BOARD NO.3**

44. **INSTALL DECK FLOOR BOX REAR**

45. **INSTALL REAR FLOOR BOARD NO.2**

46. **POWER WINDOW CONTROL SYSTEM INITIALIZE (See page 01-28)**