

POWER STEERING SYSTEM

510GU-01

PRECAUTION

1. HANDLING PRECAUTIONS FOR SRS AIRBAG SYSTEM (SEE PAGE 60-1)

NOTICE:

Some service operations affect the SRS airbag. Be sure to read the precautionary notice for the SRS airbag before servicing.

2. PRECAUTIONS FOR REMOVAL, INSTALLATION AND REPLACEMENT OF ELECTRONIC MOTOR POWER STEERING COMPONENTS

- (a) Be sure to align the front wheels straight ahead when removing and installing the steering gear assy.
- (b) When disconnecting the sliding yoke of the steering column and the pinion shaft of the steering gear assy, be sure to put matchmarks before starting the operation.
- (c) When any component related to the steering system has been removed and either reinstalled or replaced, perform steering center point adjustment (zero point calibration) (see page 05-1211).
- (d) When disconnecting the connector related to the electronic motor power steering system, turn the power switch on (IG) (the engine and the hybrid system are stopped), center the steering wheel, turn the power switch off, and then disconnect the connector.
- (e) When reconnecting the connector related to the electronic motor power steering system, ensure that the power switch is off. Center the steering wheel and then turn the power switch on (IG) (the engine and the hybrid system are stopped).

NOTICE:

Do not turn the power switch on (IG) (the engine and the hybrid system are stopped) when the steering wheel is not centered.

- (f) If procedures (d) and (e) are not carried out properly, the steering center point (zero point) will deviate, which may lead to a difference in steering effort between right and left. If there is a difference in steering effort between right and left, perform steering center point adjustment (zero point calibration) (see page 05-1211).

NOTICE FOR INITIALIZATION:

When disconnecting the negative (-) battery terminal, initialize the following systems after the terminal is reconnected.

System Name	See Page
Power Window Control System	01-28

NOTICES FOR HYBRID SYSTEM ACTIVATION:

- ◆ When the warning lamp is illuminated or the battery has been disconnected and reconnected, pressing the power switch may not start the system on the first try. If so, press the power switch again.
- ◆ With the power switch’s power mode changed to ON (IG), disconnect the battery. If the key is not in the key slot during reconnection, DTC B2799 may be output.

SYSTEM DESCRIPTION

- ◆ A rack and pinion type steering gear is used on all models.
- ◆ The Prius uses a vehicle-speed sensing type EPS (Electric Power Steering) as standard equipment on all models.

COMPONENTS:

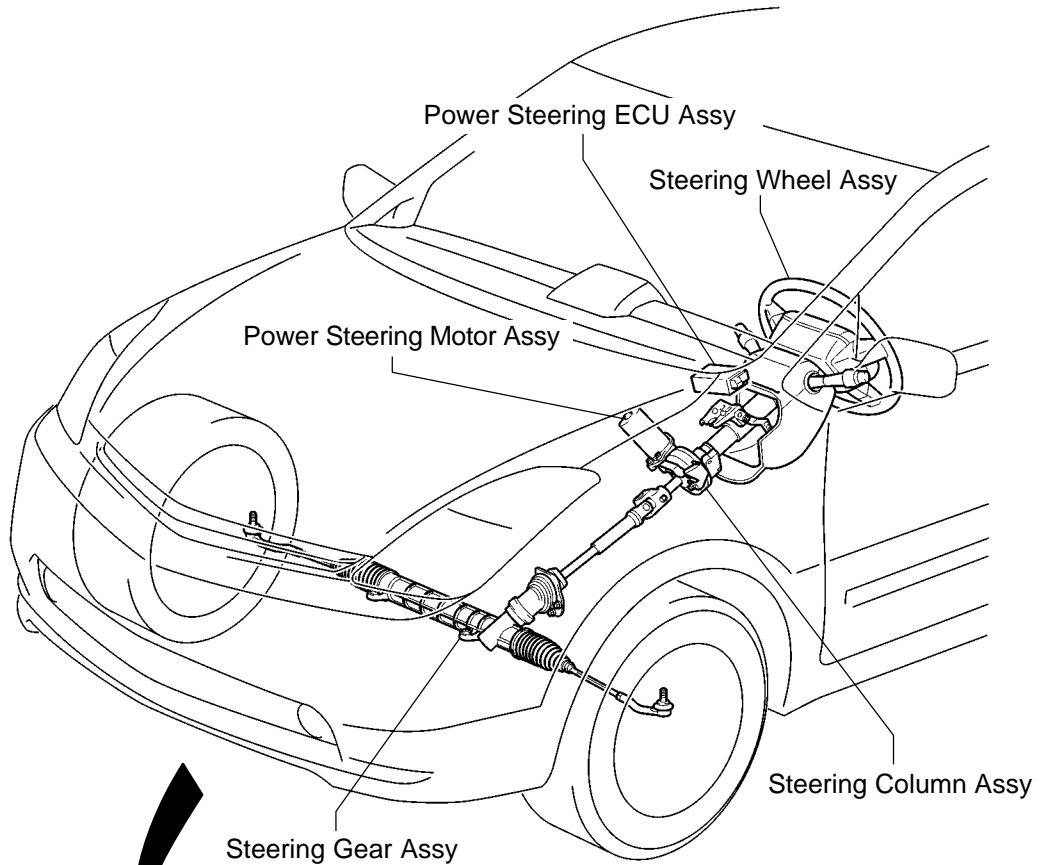

POWER STEERING TORQUE FLOWCHART:

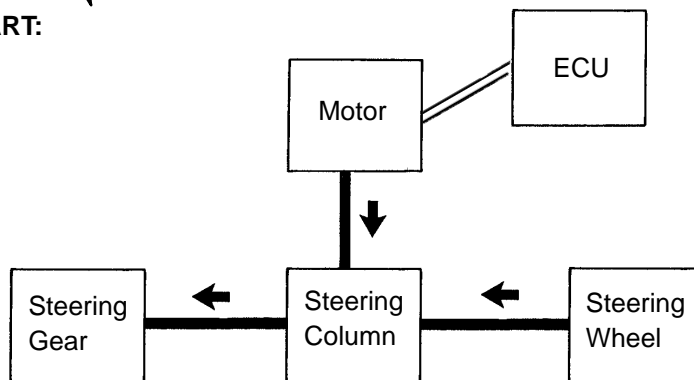

PROBLEM SYMPTOMS TABLE

Symptom	Inspection Area	See page
Steering is heavy.	<ul style="list-style-type: none"> ◆Front tires (improperly inflated, unevenly worn) ◆Front wheel alignment (Incorrect) ◆Front suspension (Lower ball joint) ◆Steering gear assy ◆Torque sensor (built into steering column) ◆Steering column assy ◆Power steering motor ◆Battery and power source system ◆Power steering ECU 	<ul style="list-style-type: none"> 28-1 26-6 26-22 51-6 50-8 50-8 50-8 2 50-16
Steering effort differs between right and left or is uneven.	<ul style="list-style-type: none"> ◆Steering center point (zero point) (not recorded completely) ◆Front tires (improperly inflated, unevenly worn) ◆Front wheel alignment (Incorrect) ◆Front suspension (Lower ball joint) ◆Steering gear assy ◆Torque sensor (built into steering column) ◆Steering column assy ◆Power steering motor ◆Power steering ECU 	<ul style="list-style-type: none"> 05-1211 28-1 26-6 26-22 51-6 50-8 50-8 50-8 50-16
While driving, steering effort does not change in accordance with vehicle speed or steering wheel does not return properly.	<ul style="list-style-type: none"> ◆Front suspension ◆Speed sensor ◆Skid control ECU ◆Combination meter ◆Engine speed detection circuit ◆Torque sensor (built into steering column) ◆Power steering motor ◆Power steering ECU 	<ul style="list-style-type: none"> 26-6 2 32-68 2 2 50-8 50-8 50-16
Knocking (or clunking) sound occurs when turning steering wheel back and forth while power steering is in operation.	<ul style="list-style-type: none"> ◆Front suspension ◆Steering intermediate shaft ◆Steering gear assy 	<ul style="list-style-type: none"> 26-6 2 50-8
Friction sound occurs when turning steering wheel during low speed driving.	<ul style="list-style-type: none"> ◆Power steering motor ◆Steering column assy 	<ul style="list-style-type: none"> 50-8 50-8
High-pitched sound (squeaking) occurs when turning steering wheel slowly with vehicle stopped.	<ul style="list-style-type: none"> ◆Power steering motor 	<ul style="list-style-type: none"> 50-8
Steering wheel vibrates and noise occurs when turning steering wheel from lock to lock.	<ul style="list-style-type: none"> ◆Power steering motor ◆Steering column assy 	<ul style="list-style-type: none"> 50-8 50-8

ON-VEHICLE INSPECTION

1. CHECK STEERING EFFORT (TORQUE)

NOTICE:

Some service operations affect the SRS airbag. Be sure to read the precautionary notice for the SRS airbag before servicing.

- (a) Stop the vehicle on a level, paved road and align the wheels straight ahead.
- (b) Disconnect the negative (-) battery terminal (see page 60-1).
- (c) Remove the horn button assy (see page 60-20).
- (d) Connect the negative (-) battery terminal.
- (e) Using a torque wrench, check if the steering wheel set nut is properly tightened.

Torque: 50 N·m (510 kgf·cm, 37 ft·lbf)

- (f) Turn the power switch on (IG) (the engine and the hybrid system are stopped) so that power steering is ready to operate.

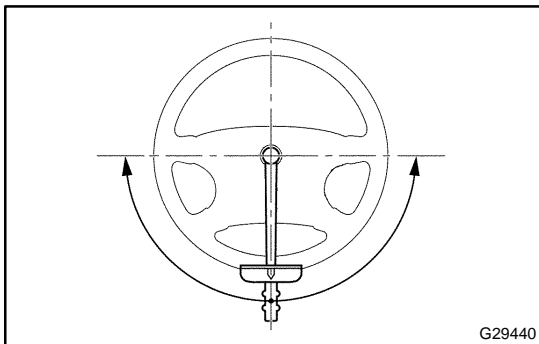

- (g) Turn the steering wheel 90 degrees to the right and check steering effort (torque) while turning. Check in the opposite direction using the same manner.

Steering effort (Reference):

5.5 N·m (56 kgf·cm, 49 in·lbf)

- (h) Align the front wheels straight ahead.
- (i) Disconnect the negative (-) battery terminal (see page 60-1).
- (j) Install the horn button assy (see page 60-20).
- (k) Connect the negative (-) battery terminal.
- (l) Clear the DTCs (see page 05-1402).
- (m) Perform initialization (see page 01-28).
- (n) Inspect the airbag warning light (see page 05-1397).

2. CHECK STEERING WHEEL FREEPLAY

- (a) Turn the power switch on (IG) so that power steering is ready to operate.
- (b) Align the wheels straight ahead.
- (c) Gently turn the steering wheel right and left with your finger and check steering wheel freeplay.

Maximum freeplay: 30 mm (1.18 in.)

If the freeplay is out of specifications, replace the sliding yoke sub-assy or the steering gear assy with a new one.

STEERING GEAR ASSY COMPONENTS

510GY-01

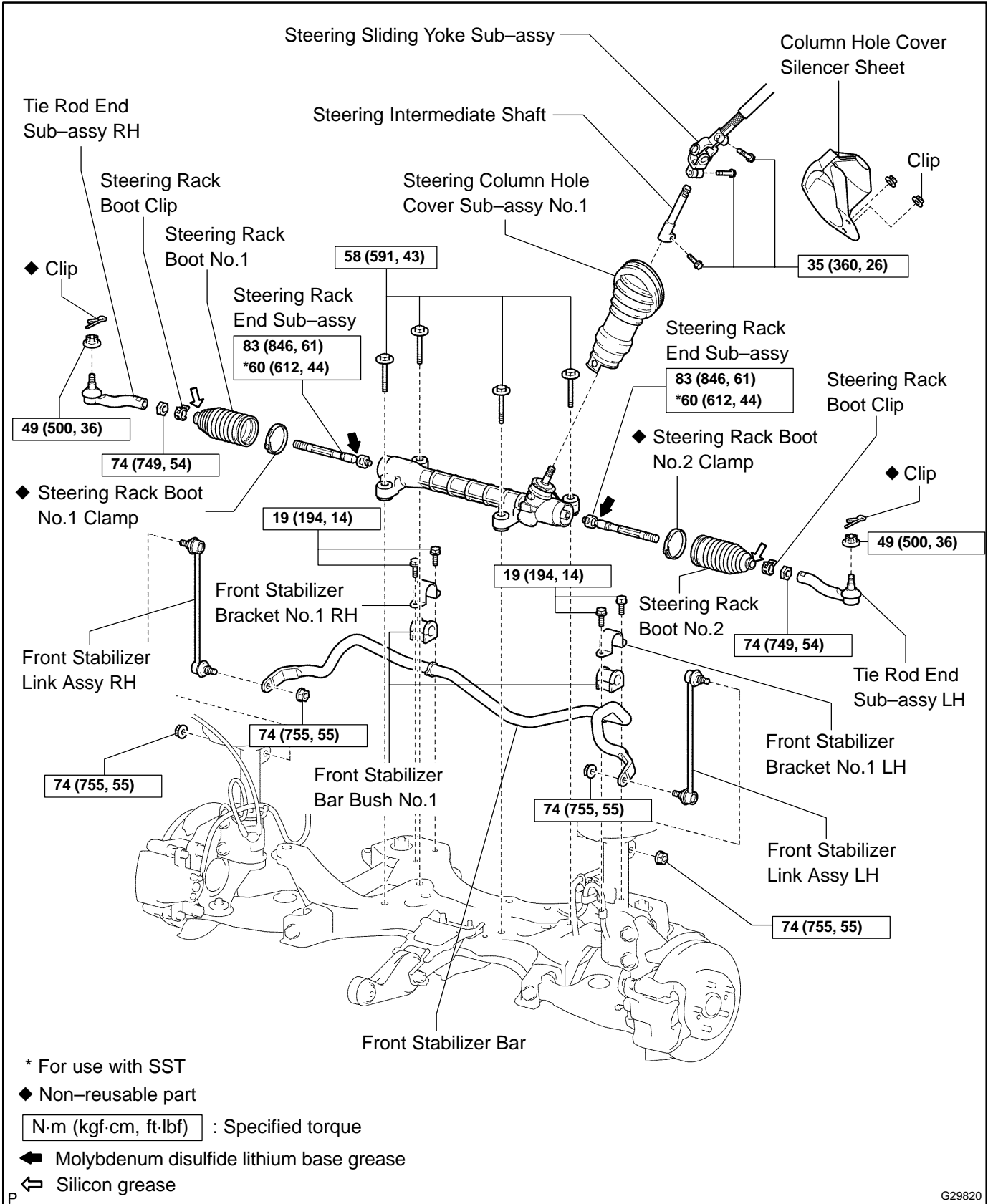

G29820

OVERHAUL

1. PLACE FRONT WHEELS FACING STRAIGHT AHEAD
2. REMOVE COLUMN HOLE COVER SILENCER SHEET (SEE PAGE 50-8)

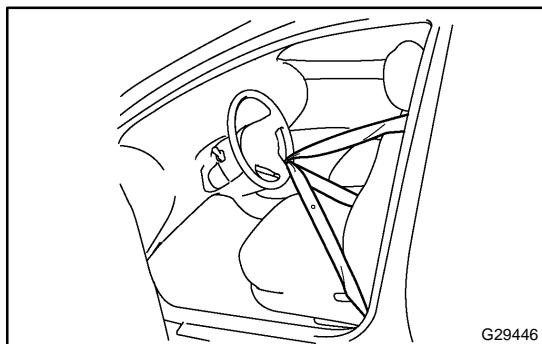

3. SEPARATE STEERING SLIDING YOKE SUB-ASSY
 - (a) Fix the steering wheel assy with the seat belt in order to prevent rotation and damage to the spiral cable.

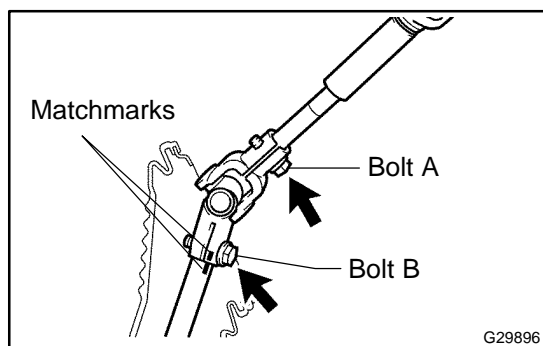

- (b) Put matchmarks on the sliding yoke sub-assy and the intermediate shaft.
 - (c) Loosen bolt A and remove bolt B to separate the sliding yoke sub-assy.

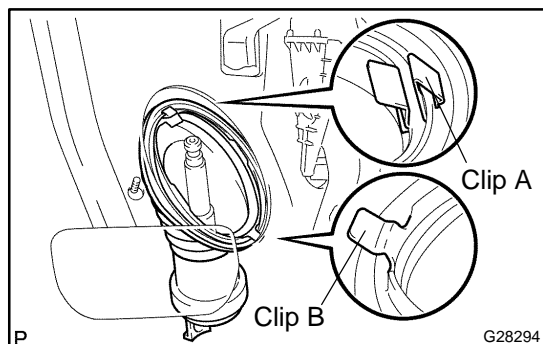

4. SEPARATE STEERING COLUMN HOLE COVER SUB-ASSY NO.1

- (a) Remove clip A and separate the column hole cover No.1 from the body.

NOTICE:
Do not damage clip B.

5. REMOVE FRONT WHEELS
6. SEPARATE TIE ROD END SUB-ASSY LH (SEE PAGE 30-7)
7. SEPARATE TIE ROD END SUB-ASSY RH

HINT:

Perform the same procedure as for the LH.

8. REMOVE FRONT STABILIZER LINK ASSY (SEE PAGE 26-25)

HINT:

Remove both LH and RH.

9. REMOVE FRONT STABILIZER BRACKET NO.1 LH (SEE PAGE 26-25)

10. REMOVE FRONT STABILIZER BRACKET NO.1 RH

HINT:

Perform the same procedure as for the LH.

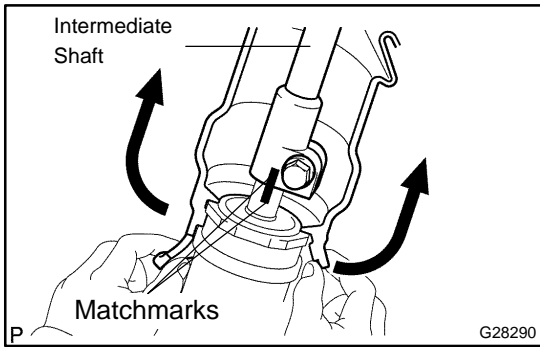

11. REMOVE STEERING INTERMEDIATE SHAFT

- (a) Move the column hole cover No.1 to the upper side of the vehicle and put matchmarks on the intermediate shaft and the steering gear assy.

NOTICE:

Do not damage the hole cover No.1 when moving it.

- (b) Remove the bolt and remove the intermediate shaft from the inside of the vehicle.
- (c) Remove the column hole cover No.1 from the steering gear assy.

NOTICE:

Do not damage the hole cover No.1 clip.

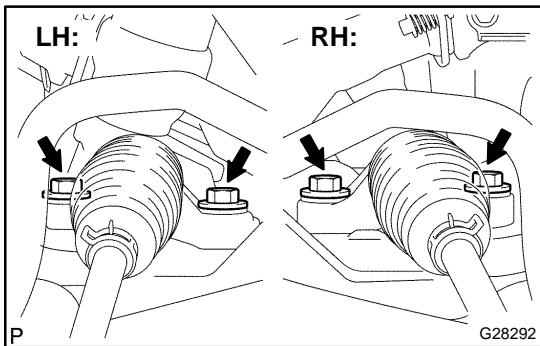

12. REMOVE STEERING GEAR ASSY

- (a) Remove the 4 bolts and remove the steering gear assy from the left side of the vehicle.

HINT:

Be careful not to hit the stabilizer bar when removing the steering gear assy.

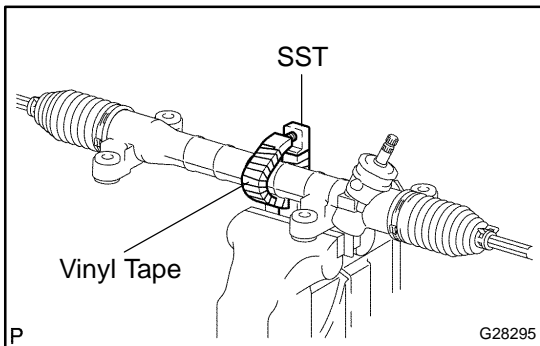

13. FIX STEERING GEAR ASSY

- (a) Using SST wrapped with protection tape, secure the steering gear assy in a vise.
SST 09612-00012

HINT:

Remove and reinstall the SST as needed.

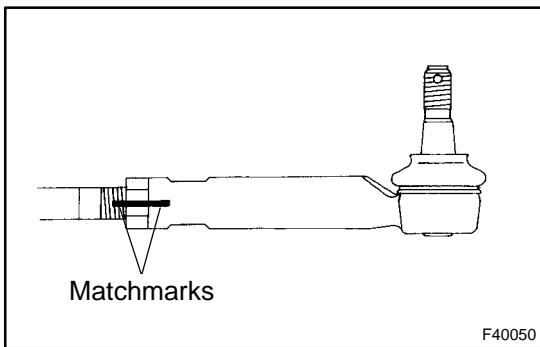

14. REMOVE TIE ROD END SUB-ASSY LH

- (a) Put matchmarks on the tie rod end sub-assy LH and the rack end.
- (b) Remove the tie rod end sub-assy LH and the lock nut.

15. REMOVE TIE ROD END SUB-ASSY RH

HINT:

Perform the same procedure as for the LH.

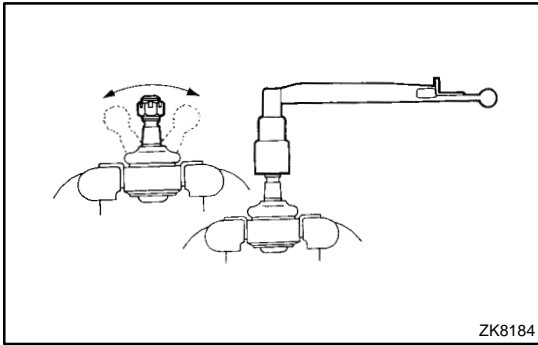
**16. INSPECT TIE ROD END SUB-ASSY LH**

- (a) Secure the tie rod end sub-assy LH ball joint in a vise through aluminum plates.

NOTICE:

Do not overtighten the vise.

- (b) Install the castle nut to the stud bolt.
 (c) Flip the ball joint back and forth 5 times or more.
 (d) Set a torque wrench to the nut, turn the ball joint continuously at a rate of 3 to 5 seconds per turn, and check the turning torque on the 5th turn.

Turning torque:

2.0 N·m (20.4 kgf·cm, 18 in. lbf) or less

If turning torque is out of specifications, replace the tie rod end sub-assy LH with a new one.

17. INSPECT TIE ROD END SUB-ASSY RH**HINT:**

Perform the same procedure as for the LH.

18. REMOVE STEERING RACK BOOT CLIP

- (a) Using pliers, remove the 2 rack boot clips (RH and LH).

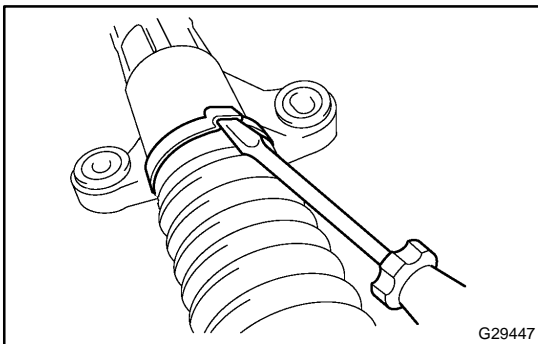
**19. REMOVE STEERING RACK BOOT NO.2 CLAMP**

- (a) Using a screwdriver, unseat and remove the rack boot clamp No.2.

NOTICE:

Do not damage the rack boot No.2.

20. REMOVE STEERING RACK BOOT NO.1 CLAMP**HINT:**

Perform the same procedure as for the rack boot clamp No.2.

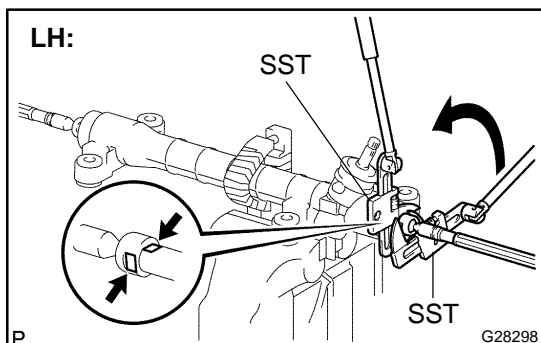
21. REMOVE STEERING RACK BOOT NO.2**22. REMOVE STEERING RACK BOOT NO.1****23. REMOVE STEERING RACK END SUB-ASSY**

- (a) Using 2 SST, remove the rack end sub-assy (LH side).
 SST 09922-10010

NOTICE:

- ◆ Use the SST in the correct direction as shown in the illustration.
- ◆ Securely hold the steering rack.

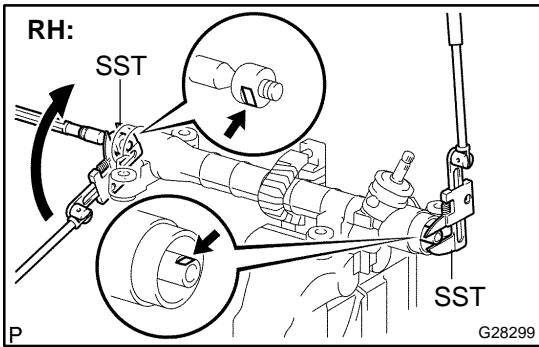

- (b) Using 2 SST, hold the steering rack LH side and remove the rack end sub-assy (RH side).
SST 09922-10010

NOTICE:

- ◆ Use the SST in the correct direction as shown in the illustration.
- ◆ Securely hold the steering rack.

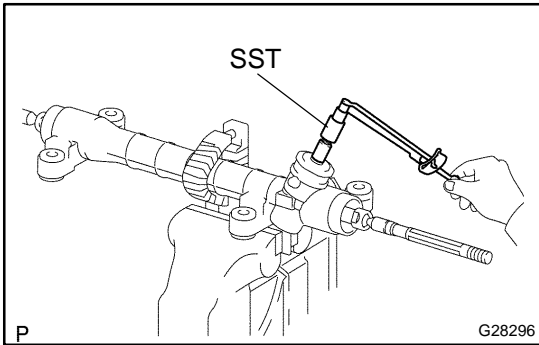

24. INSPECT TOTAL PRELOAD

- (a) Using SST, inspect total preload.
SST 09616-00011

Preload (turning):

0.6 to 1.2 N·m (6.1 to 12.2 kgf·cm, 5 to 11 in.·lbf)

NOTICE:

Inspect around the steering rack center position.

If total preload is out of specifications, replace the steering gear assy with a new one.

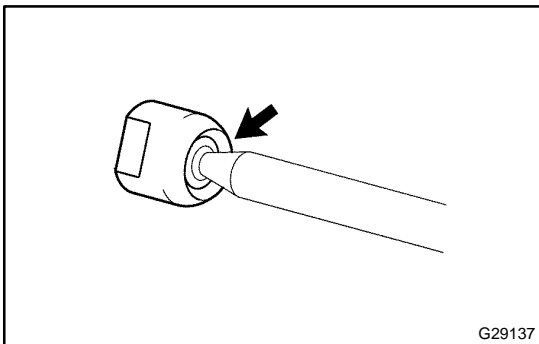

25. INSTALL STEERING RACK END SUB-ASSY

- (a) Fill up the ball joints of the RH and LH rack ends with molybdenum disulfide lithium base grease.

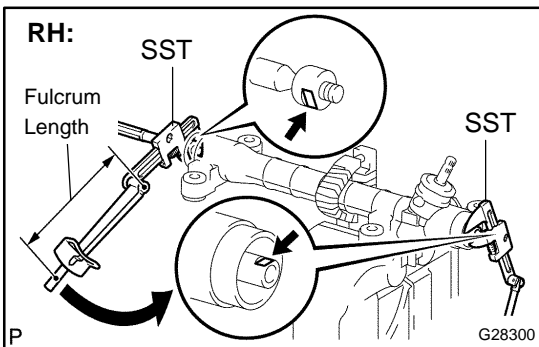

- (b) Using 2 SST, hold the steering rack LH side and install the rack end sub-assy (RH side).
SST 09922-10010
Torque: 60 N·m (612 kgf·cm, 44 ft·lbf)

NOTICE:

- ◆ Use a torque wrench with a fulcrum length of 345 mm (13.58 in.).
- ◆ Use the SST in the correct direction as shown in the illustration.
- ◆ Securely hold the steering rack.

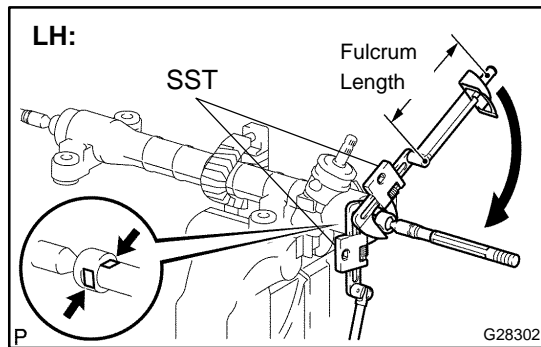

- (c) Using 2 SST, install the rack end sub-assy (LH side).
SST 09922-10010
Torque: 60 N·m (612 kgf·cm, 44 ft·lbf)

NOTICE:

- ◆ Use a torque wrench with a fulcrum length of 345 mm (13.58 in.).
- ◆ Use the SST in the correct direction as shown in the illustration.
- ◆ Securely hold the steering rack.

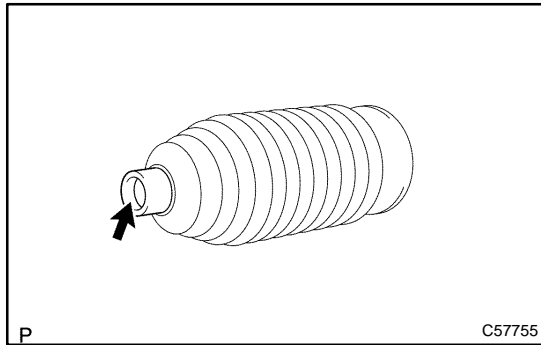
**26. INSTALL STEERING RACK BOOT NO.2**

- (a) Apply silicon grease to the inside of the small opening of the rack boot No.2.
(b) Install the rack boot No.2 in the groove on the rack housing.

NOTICE:

Make sure that the rack boot No.2 is not twisted.

27. INSTALL STEERING RACK BOOT NO.1**HINT:**

Perform the same procedure as for the rack boot No.2.

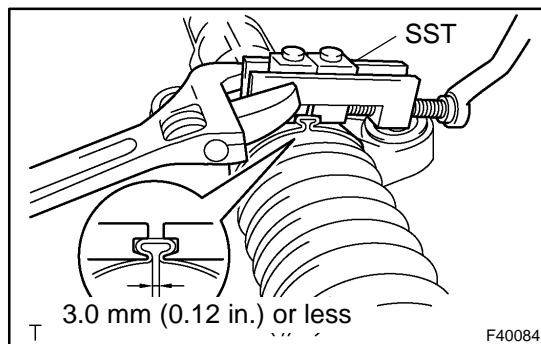
**28. INSTALL STEERING RACK BOOT NO.2 CLAMP**

- (a) Install a new rack boot clamp No.2 to the rack boot No.2.

NOTICE:

Do not damage the rack boot No.2.

- (b) While pushing SST to the rack housing, pinch the rack boot clamp No.2 so that clearance is within specifications.
SST 09521-24010

Clearance: 3.0 mm (0.12 in.) or less

NOTICE:

Make sure that the rack boot No.2 is not twisted.

29. INSTALL STEERING RACK BOOT NO.1 CLAMP

SST 09521-24010

HINT:

Perform the same procedure as for the rack boot clamp No.2.

30. INSTALL STEERING RACK BOOT CLIP

- (a) Using pliers, install the 2 rack boot clips to the RH and LH rack boots.

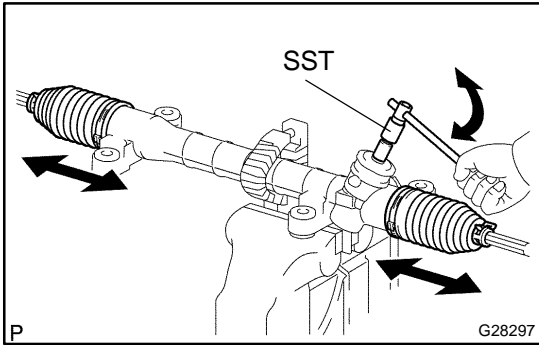

31. INSPECT STEERING GEAR ASSY

- (a) Using SST, turn the pinion shaft and check that the RH and LH rack boots expand and contract smoothly.
SST 09616-00011

If the rack boot does not expand and contract smoothly, reinstall it with a new rack boot clamp.

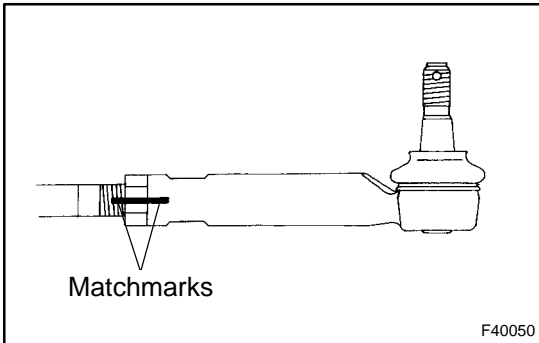

32. INSTALL TIE ROD END SUB-ASSY LH

- (a) Screw the lock nut and the tie rod end sub-assy LH on the rack end sub-assy until the matchmarks are aligned and temporarily tighten the lock nut.

HINT:

Fully tighten the lock nut after adjusting toe-in.

33. INSTALL TIE ROD END SUB-ASSY RH

HINT:

Perform the same procedure as for the LH.

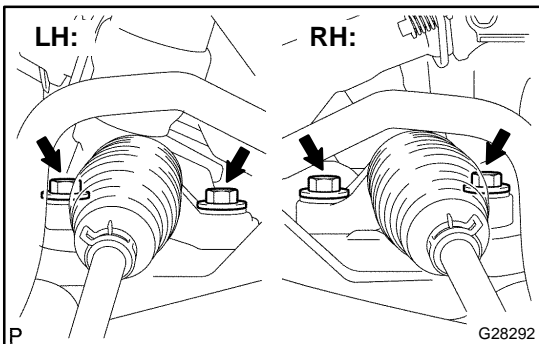

34. INSTALL STEERING GEAR ASSY

- (a) Install the steering gear assy from the left side of the vehicle.

HINT:

Be careful not to hit the stabilizer bar when installing the steering gear assy.

- (b) Install the column hole cover No.1 to the steering gear assy.
- (c) Install the steering gear assy to the crossmember with the 4 bolts.

Torque: 58 N·m (591 kgf·cm, 43 ft·lbf)

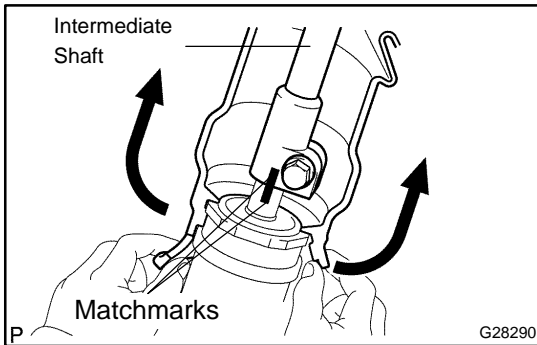
**35. INSTALL STEERING INTERMEDIATE SHAFT**

- (a) Move the column hole cover No.1 to the upper side of the vehicle, align the matchmarks, and install the intermediate shaft from the inside of the vehicle.

NOTICE:

Do not damage the hole cover No.1 when moving it.

- (b) Install the bolt.

Torque: 35 N·m (360 kgf·cm, 26 ft·lbf)

- (c) Fit the recessed part on the column hole cover No.1 to the steering gear assy.

NOTICE:

Make sure that the hole cover No.1 is securely installed.

36. INSTALL FRONT STABILIZER BRACKET NO.1 LH (SEE PAGE 26-25)**37. INSTALL FRONT STABILIZER BRACKET NO.1 RH****HINT:**

Perform the same procedure as for the LH.

38. INSTALL FRONT STABILIZER LINK ASSY (SEE PAGE 26-25)**39. INSTALL TIE ROD END SUB-ASSY LH (SEE PAGE 30-7)****40. INSTALL TIE ROD END SUB-ASSY RH****HINT:**

Perform the same procedure as for the LH.

41. INSTALL FRONT WHEELS

Torque: 103 N·m (1,050 kgf·cm, 76 ft·lbf)

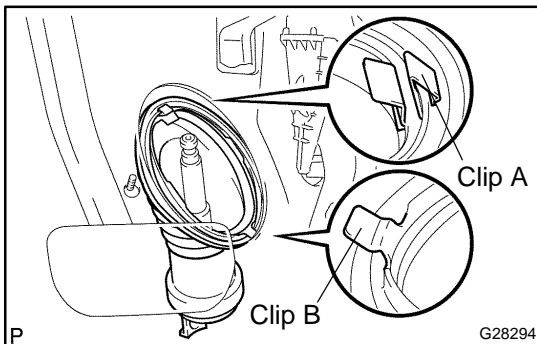
**42. INSTALL STEERING COLUMN HOLE COVER SUB-ASSY NO.1**

- (a) Install clip B to the vehicle body and install the column hole cover No.1 to the vehicle body with clip A.

NOTICE:

Make sure that the hole cover No.1 lip fits on the dash panel correctly.

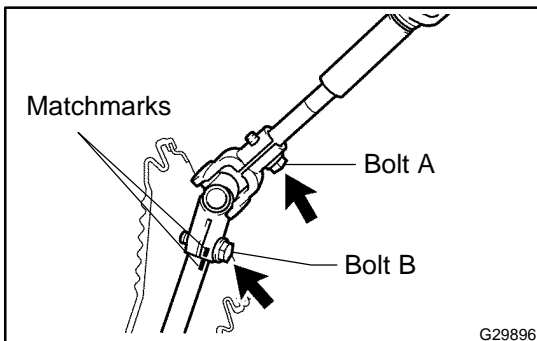
**43. INSTALL STEERING SLIDING YOKE SUB-ASSY**

- (a) Align the matchmarks and install the sliding yoke sub-assy to the intermediate shaft with bolt B.

Torque: 35 N·m (360 kgf·cm, 26 ft·lbf)

- (b) Tighten bolt A.

Torque: 35 N·m (360 kgf·cm, 26 ft·lbf)

44. INSTALL COLUMN HOLE COVER SILENCER SHEET (SEE PAGE 50-8)**45. PLACE FRONT WHEELS FACING STRAIGHT AHEAD****46. INSPECT AND ADJUST FRONT WHEEL ALIGNMENT (SEE PAGE 26-6)****47. PERFORM STEERING ANGLE SENSOR ZERO POINT CALIBRATION (SEE PAGE 05-1211)**