

SUPPLEMENTAL RESTRAINT SYSTEM

600RF-01

PRECAUTION

CAUTION:

- **PRIUS is equipped with SRS, which consists of a driver airbag, front passenger airbag, side airbag and curtain shield airbag. Failure to carry out service operations in the correct sequence could cause the SRS to unexpectedly deploy during servicing, possibly leading to a serious accident. Further, if a mistake is made in servicing the SRS, it is possible that the SRS may fail to operate when required. Before performing servicing (including removal or installation of parts, inspection or replacement), be sure to read the following items carefully, then follow the correct procedures indicated in the repair manual.**
- **Wait at least 90 seconds after the power switch is turned off and the negative (–) terminal cable is disconnected from the battery before starting the operation.**
(The SRS is equipped with a back-up power source, so that if work is started within 90 seconds after disconnecting the negative (–) terminal cable of the battery, the SRS may be deployed.)
- **Do not expose the horn button assy, front passenger airbag assy, airbag sensor assy center, airbag sensor front, front seat airbag assy, side airbag sensor assy, curtain shield airbag assy, airbag sensor rear or seat position airbag sensor directly to hot air or flames.**

NOTICE:

- **Malfunction symptoms of the SRS are difficult to confirm, so DTCs are the most important source of information when troubleshooting. When troubleshooting the SRS, always inspect DTCs before disconnecting the battery.**
- **Even in the case of a minor collision when the SRS does not deploy, the horn button assy, front passenger airbag assy, airbag sensor assy center, airbag sensor front, front seat airbag assy, side airbag sensor assy, curtain shield airbag assy, airbag sensor rear and seat position airbag sensor should be inspected (see page 60-14).**
- **Before repair work, remove the airbag sensor if any kind of shock is likely to occur to the airbag sensor during the operation.**
- **Never use SRS parts from another vehicle. When replacing the parts, replace them with new ones.**
- **Never disassemble or repair the horn button assy, front passenger airbag assy, airbag sensor assy center, airbag sensor front, front seat airbag assy, side airbag sensor assy, curtain shield airbag assy, airbag sensor rear or seat position airbag sensor in order to reuse it.**
- **If the horn button assy, front passenger airbag assy, airbag sensor assy center, airbag sensor front, front seat airbag assy, side airbag sensor assy, curtain shield airbag assy, airbag sensor rear or seat position airbag sensor has been dropped, or if there are any cracks, dents or other defects in the case, bracket or connector, replace it with a new one.**
- **Use a volt/ohmmeter with high impedance (10 k Ω /V minimum) for troubleshooting the electrical circuits.**
- **Information labels are attached to the periphery of the SRS components. Follow the instructions in the caution.**
- **After work on the SRS is completed, perform the SRS warning light check (see page 05-1397).**
- **When the negative (–) terminal cable is disconnected from the battery, the memory will be cleared. Because of this, be sure to make a record of the contents memorized in each system before starting work. When work is finished, adjust each system as it was before. Never use a back-up power supply from outside the vehicle to avoid erasing the memory in any system.**
- **If the vehicle is equipped with a mobile communication system, refer to the precaution in the INTRODUCTION section.**

NOTICE FOR INITIALIZATION:

When disconnecting the negative (-) battery terminal, initialize the following systems after the terminal is reconnected.

| System Name | See Page |
|-----------------------------|-----------------------|
| Power Window Control System | 01-28 |

NOTICES FOR HYBRID SYSTEM ACTIVATION:

- When the warning lamp is illuminated or the battery has been disconnected and reconnected, pressing the power switch may not start the system on the first try. If so, press the power switch again.
- With the power switch's power mode changed to ON (IG), disconnect the battery. If the key is not in the key slot during reconnection, DTC B2799 may be output.

1. SRS CONNECTORS

HINT:

SRS connectors are located as shown in the following illustration.

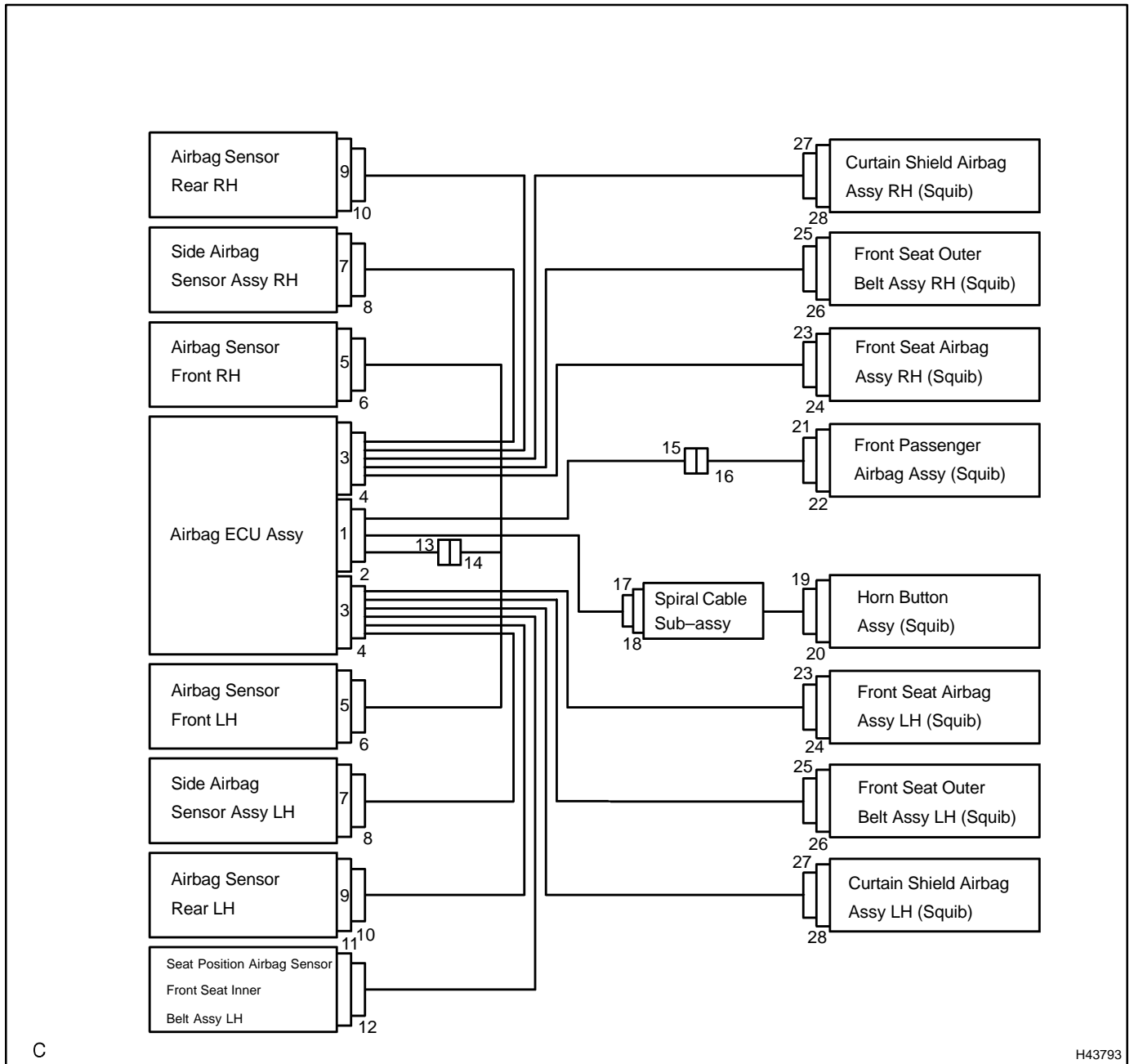

| No. | Connector Type | Application |
|-----|---|---|
| (1) | Terminal Twin-Lock Mechanism | Connectors 2, 4, 6, 8, 10, 13, 14, 17, 23, 24 |
| (2) | Activation Prevention Mechanism | Connectors 2, 4, 16, 18, 20, 22, 24, 26, 28 |
| (3) | Half Connection Prevention Mechanism | Connectors 6, 8, 10, 14, 15, 17, 23 |
| (4) | Connector Lock Mechanism (1) | Connectors 19, 21, 25, 27 |
| (5) | Connector Lock Mechanism (2) | Connectors 2, 4 |
| (6) | Improper Connection Prevention Lock Mechanism | Connectors 1, 3 |

- (a) All connectors in the SRS are colored yellow to distinguish them from other connectors, except the seat position airbag sensor connector. Some connectors have special functions, and are specially designed for the SRS. These connectors use durable gold-plated terminals, and are placed in the locations shown on the previous page to ensure high reliability.

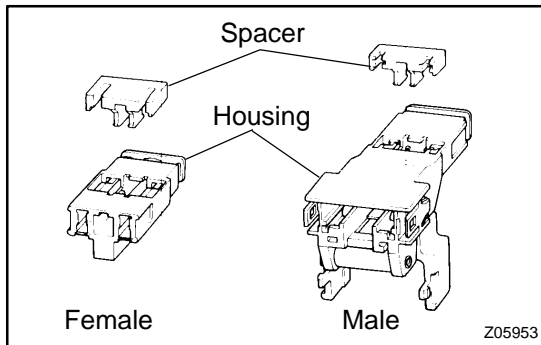

- (1) Terminal twin-lock mechanism:
Each connector has a two-piece component consisting of a housing and a spacer. This design enables the terminal to be locked securely by two locking devices (the retainer and the lance) to prevent terminals from coming out.
- (2) Activation prevention mechanism:
Each connector contains a short spring plate. When the connector is disconnected, the short spring plate automatically connects the positive (+) terminal and the negative (-) terminal of the squib.

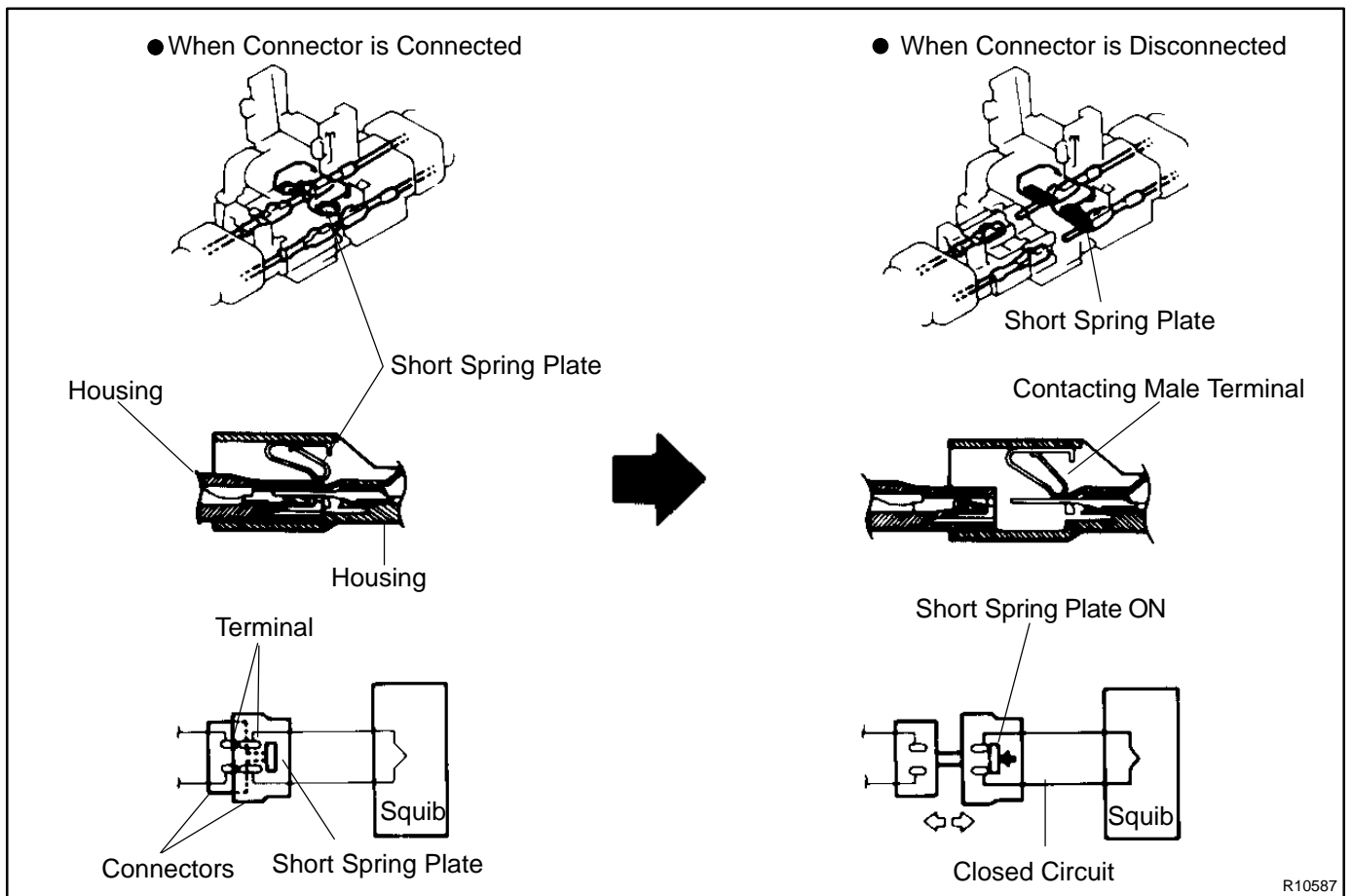

- (3) Half connection prevention mechanism:
If the connector is not completely connected, the connector is disconnected due to the spring operation so that no continuity exists.

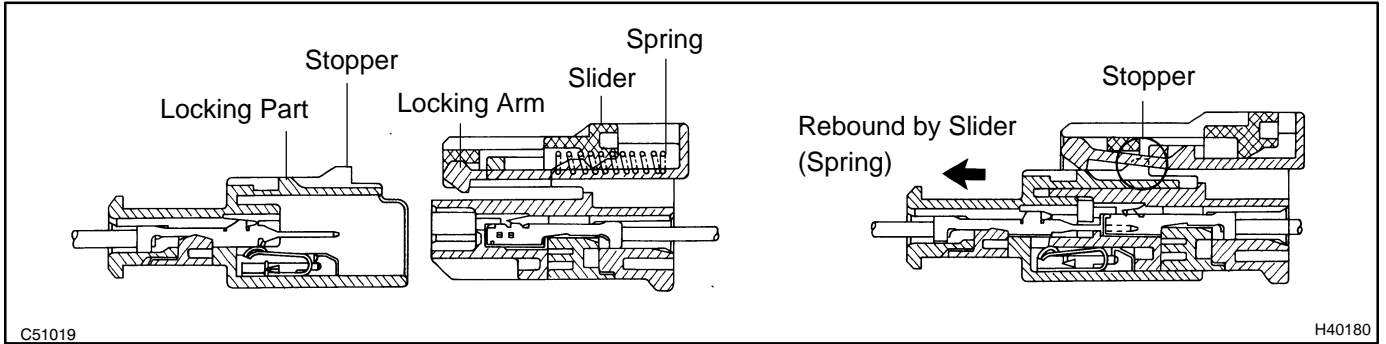

- (4) Connector lock mechanism (1):
Locking the connector lock button connects the connector securely.

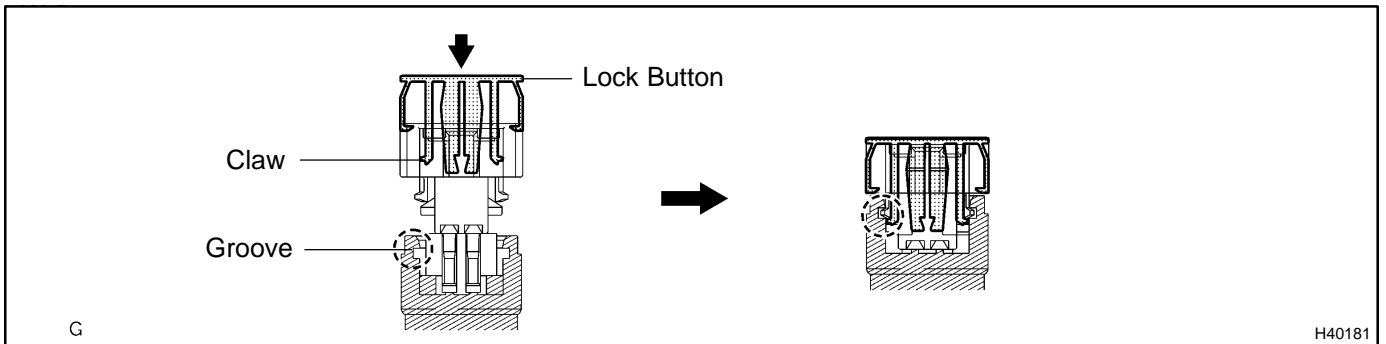

- (5) Connector lock mechanism (2): Both the primary lock with holder lances and the secondary lock with retainer prevent the connectors from becoming disconnected.

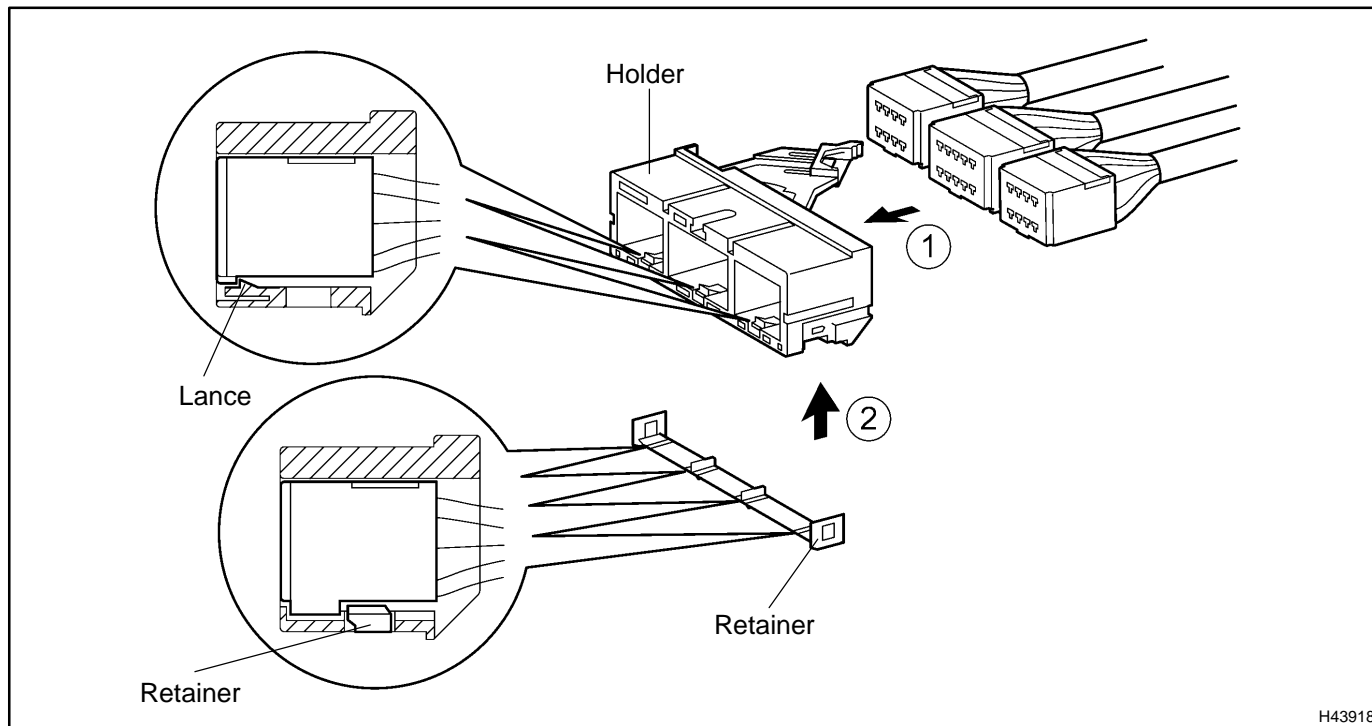

H43918

- (6) Improper connection prevention lock mechanism: When connecting the holder, the lever is pushed into the end by rotating around the A axis to lock the holder securely.

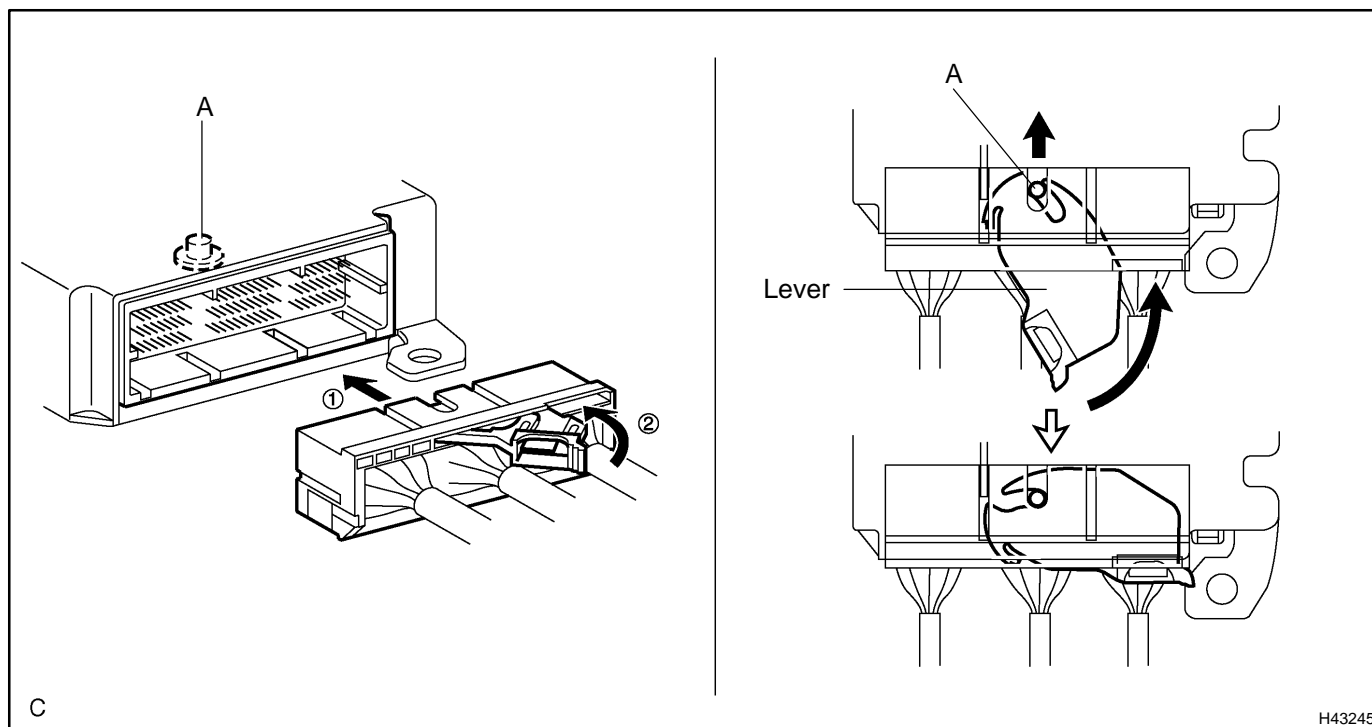

C

H43245

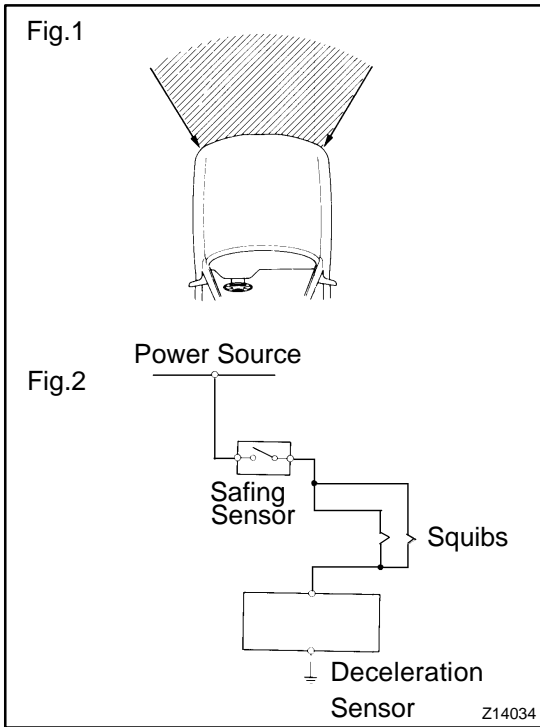

(b) When the vehicle is involved in a frontal collision in the hatched area (Fig.1) and the shock is larger than the pre-determined level, the SRS is activated automatically. The safing sensor is designed to go on at a smaller deceleration rate than the airbag sensor. As illustrated in Fig.2, ignition is caused when current flows to the squib, which happens when the safing sensor and the deceleration sensor go on simultaneously. When a deceleration force acts on the sensors, 2 squibs in the driver airbag and front passenger airbag ignite and generate gas. The gas discharging into the driver airbag and front passenger airbag rapidly increases the pressure inside the bags, breaking the horn button assy and instrument panel. The deployment of the bags then ends, and the bags deflate as the gas is discharged through discharge holes at the bag's rear or side.

2. DISCONNECTION OF CONNECTORS FOR HORN BUTTON ASSY, FRONT PASSENGER AIRBAG ASSY AND CURTAIN SHIELD AIRBAG ASSY

- (a) Release the lock button (yellow part) of the connector using a screwdriver.
- (b) Insert the screwdriver tip between the connector and the base, and then raise the connector.

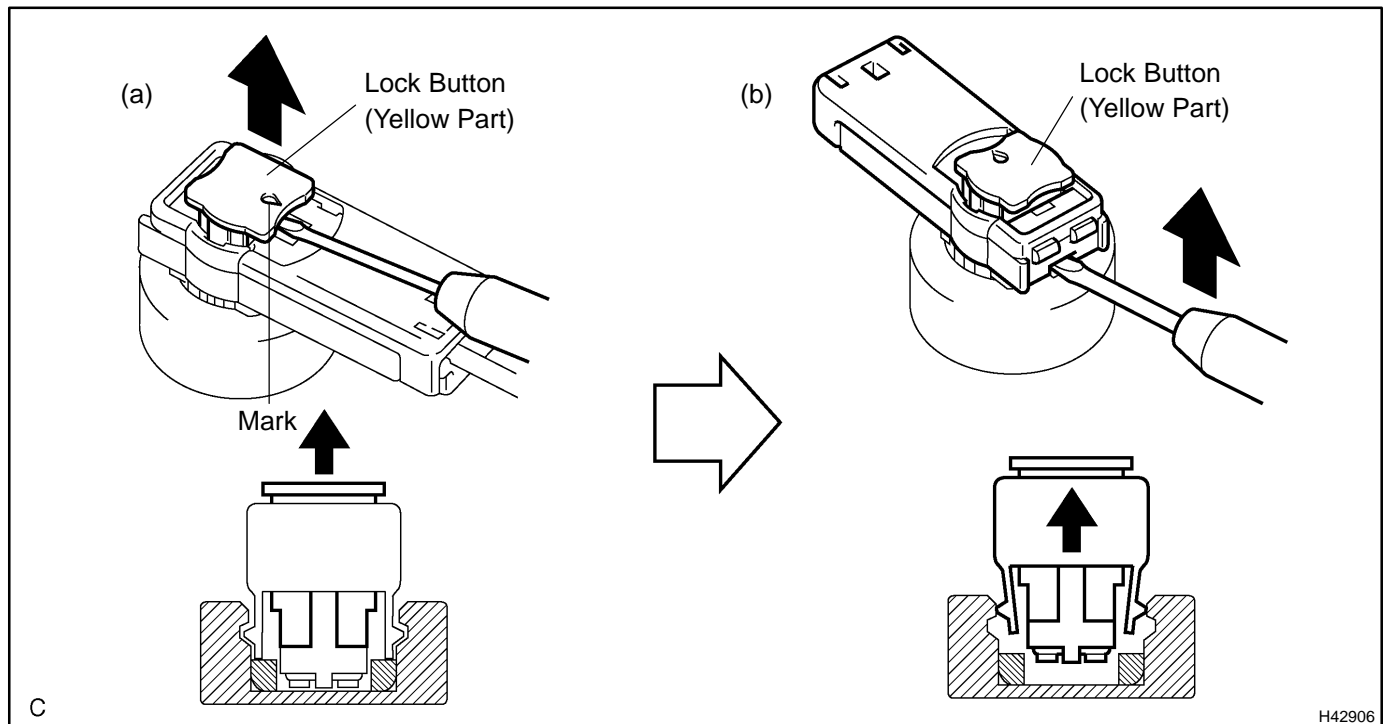

H42906

3. CONNECTION OF CONNECTORS FOR HORN BUTTON ASSY, FRONT PASSENGER AIRBAG ASSY AND CURTAIN SHIELD AIRBAG ASSY

- (a) Connect the connector.
- (b) Push down securely on the lock button (yellow part) of the connector. (When locking, a click sound can be heard.)

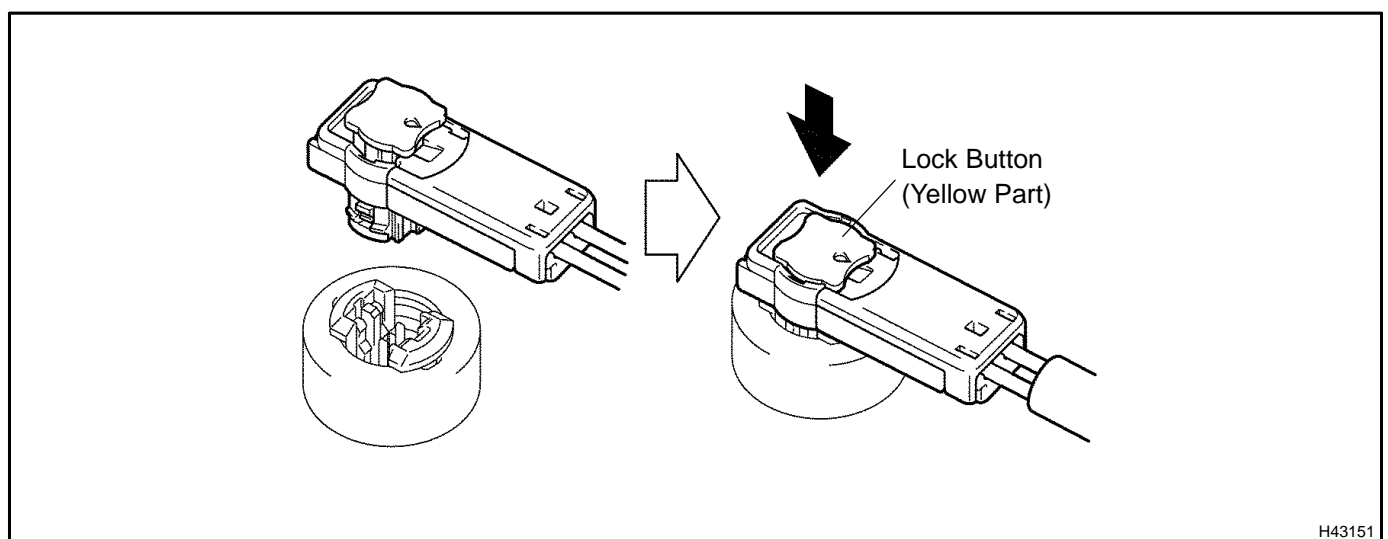

H43151

4. DISCONNECTION OF CONNECTOR FOR FRONT SEAT AIRBAG ASSY

- (a) Place a finger on the slider, slide the slider to release the lock, and then disconnect the connector.

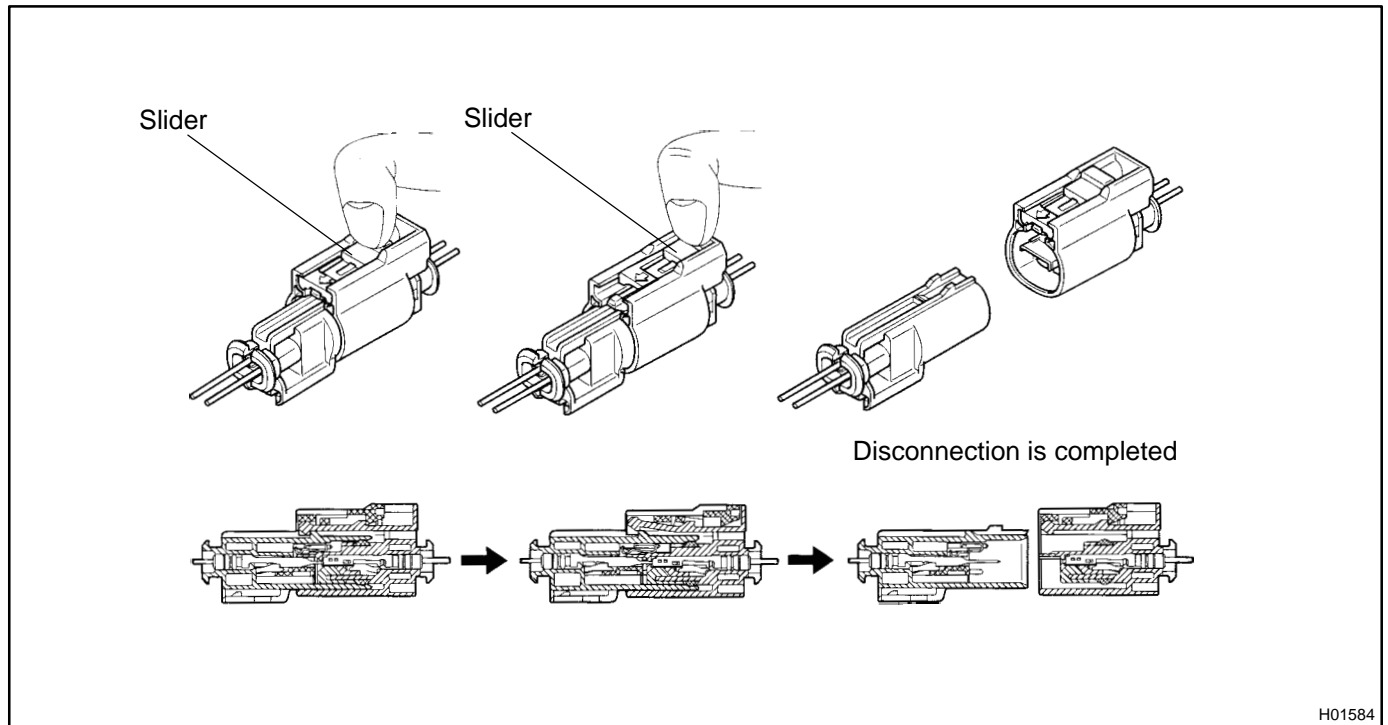

H01584

5. CONNECTION OF CONNECTOR FOR FRONT SEAT AIRBAG ASSY

- (a) Connect the connector as shown in the illustration. (When locking, make sure that the slider returns to its original position and a click sound can be heard.)

HINT:

When connecting, the slider will slide. Be sure not to touch the slider while connecting, as it may result in an insecure fit.

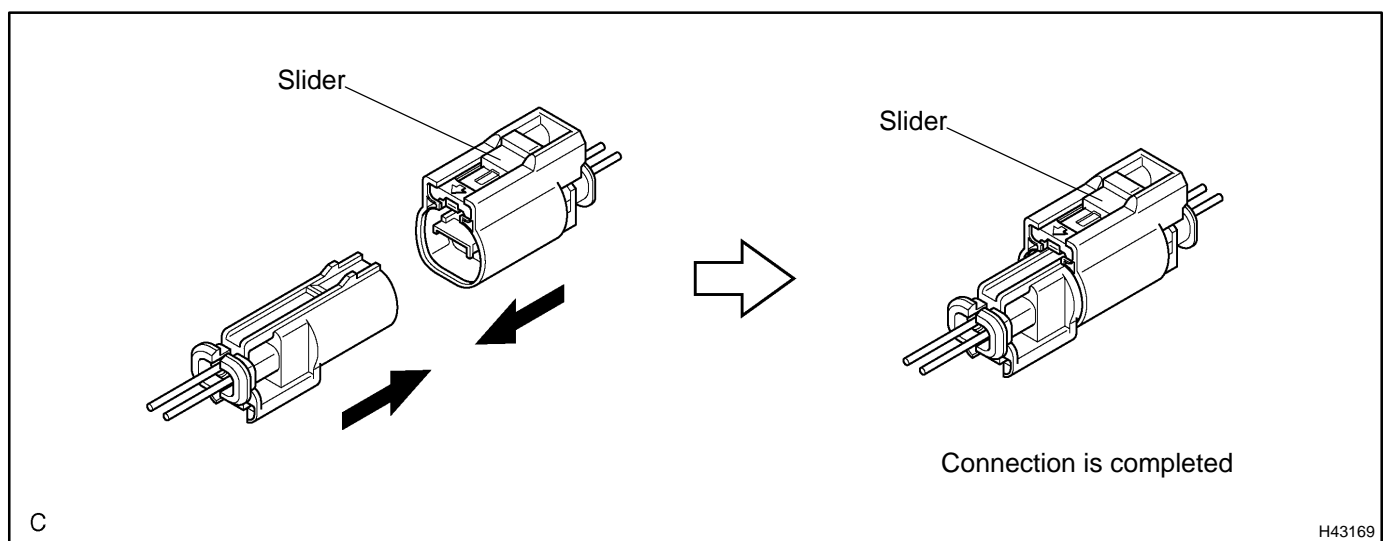

H43169

6. DISCONNECTION OF CONNECTOR FOR AIRBAG ECU ASSY

- (a) Pull the lever by pushing part A as shown in the illustration and disconnect the holder (with connectors).

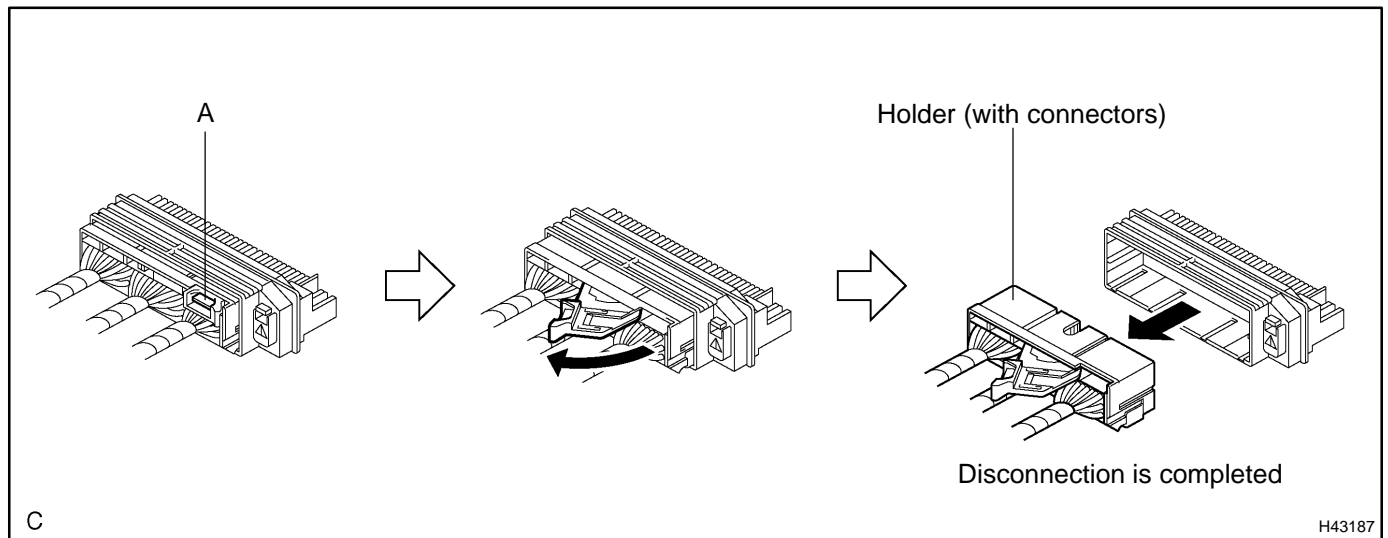
**HINT:**

Perform the following procedures when replacing the holder.

- (b) Remove the holder.
(1) Using a screwdriver, unlock the retainer.

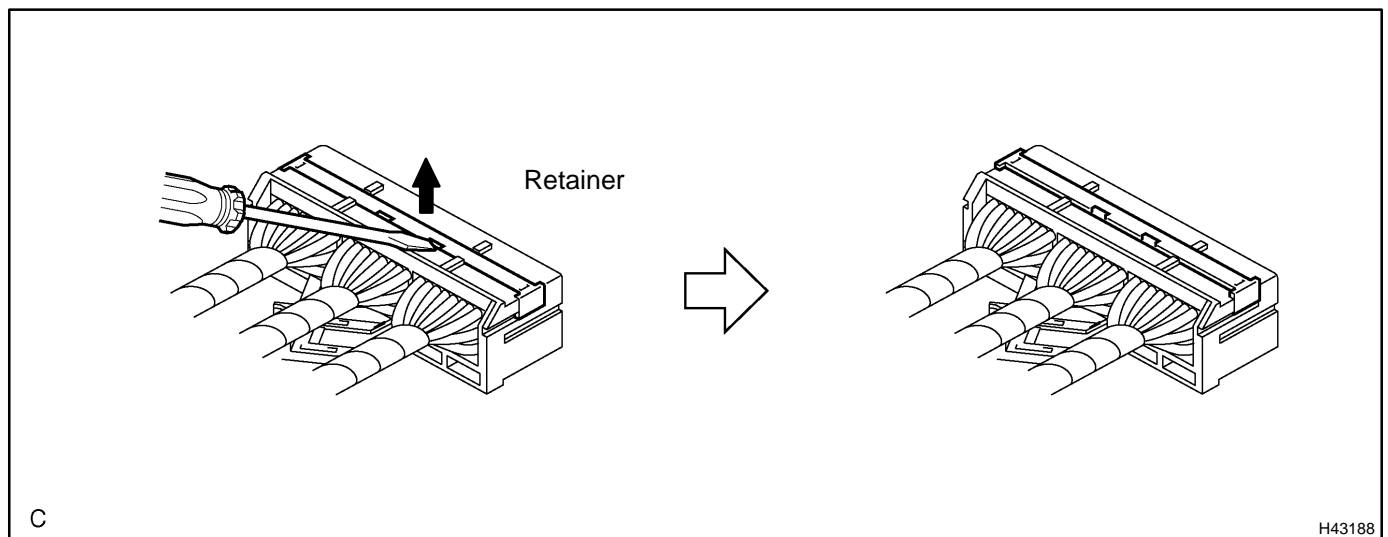

- (2) Release the lance fittings and remove the holder.

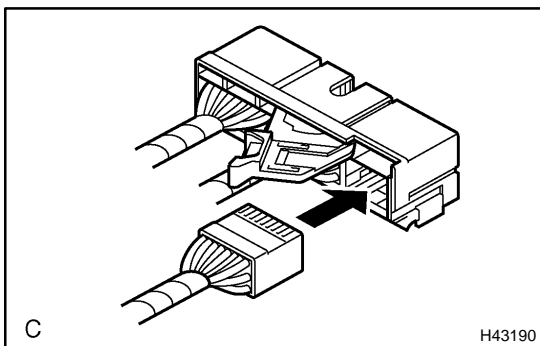
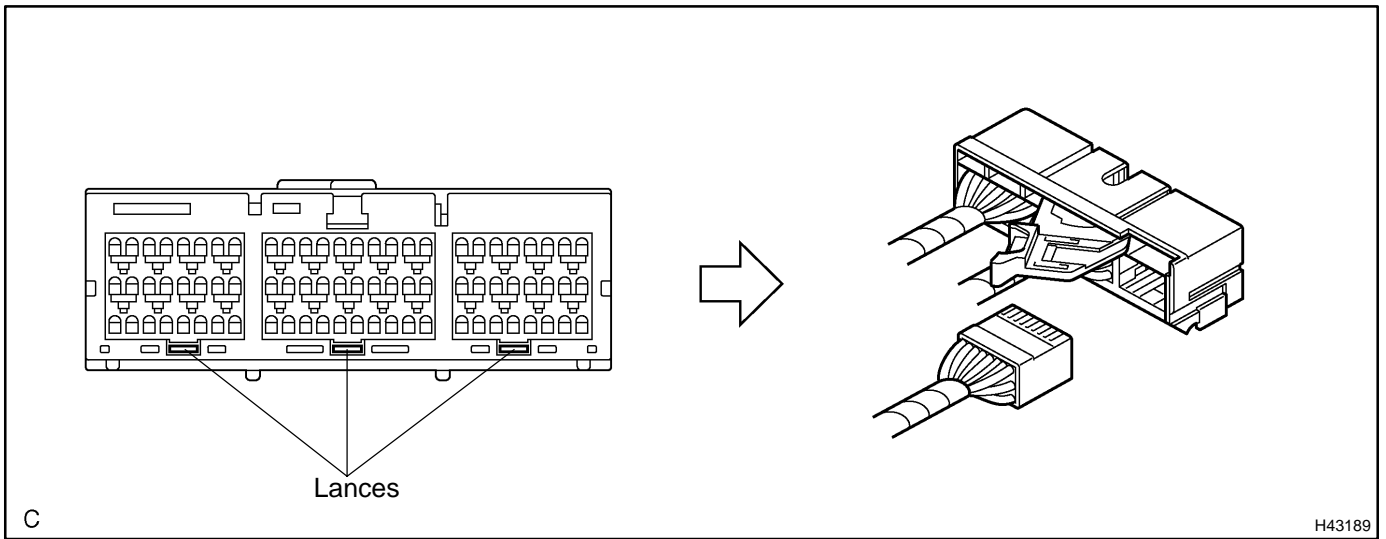

- (c) Install the holder.
 - (1) Install the connectors to the holder. (When locking, a click sound can be heard.)

HINT:
The retainer is locked when the holder is connected.

7. CONNECTION OF CONNECTOR FOR AIRBAG ECU ASSY

- (a) Firmly insert the holder (with connectors) until it can not be pushed any further.
- (b) Push the lever to connect the holder (with connectors). (When locking, a click sound can be heard.)

HINT:

The holder slides when connected. Be sure not to hold the holder while connecting, as it may result in an insecure fit.

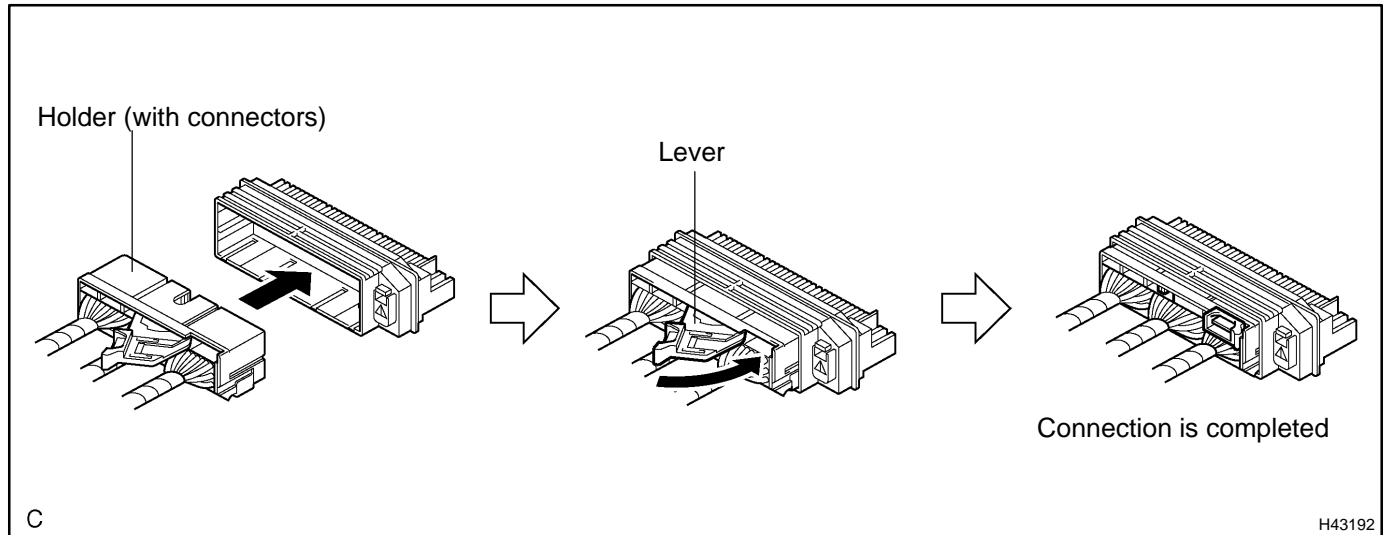

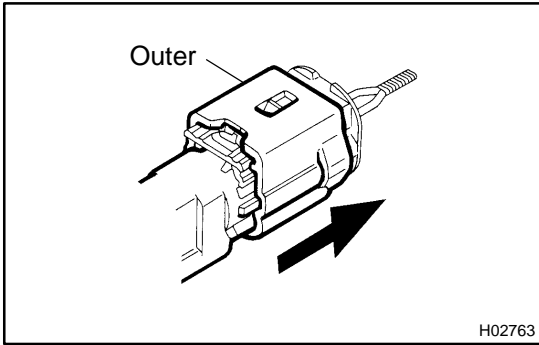

8. DISCONNECTION OF CONNECTORS FOR AIRBAG SENSOR FRONT, SIDE AIRBAG SENSOR AND AIRBAG SENSOR REAR

- (a) While holding both outer flank sides, slide the outer in the direction shown by the arrow.
- (b) When the connector lock is released, the connectors are disconnected.

HINT:

Be sure to hold both outer flank sides. Holding the top and bottom sides will make disconnection difficult.

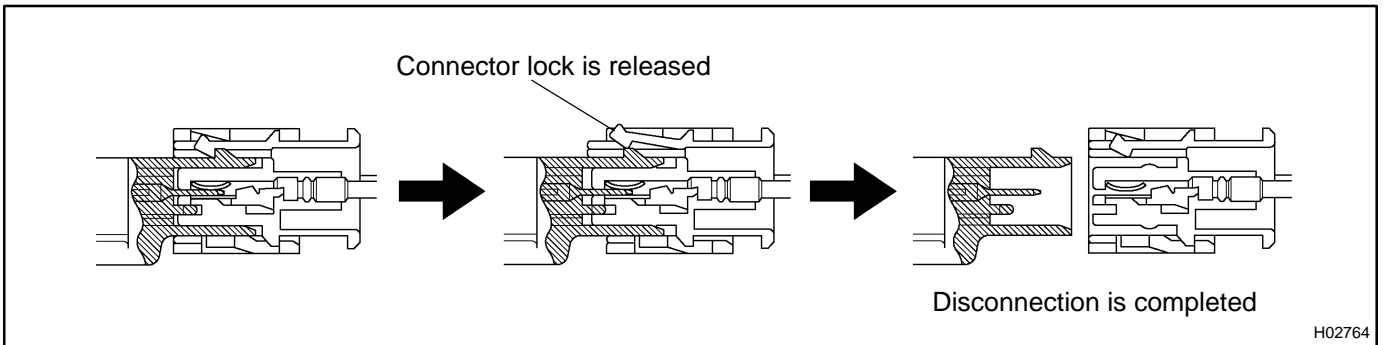

9. CONNECTION OF CONNECTORS FOR AIRBAG SENSOR FRONT, SIDE AIRBAG SENSOR AND AIRBAG SENSOR REAR

- (a) Connect the connector as shown in the illustration. (When locking, make sure that the outer returns to its original position and a click sound can be heard.)

HINT:

When connecting, the outer will slide. Be sure not to hold the outer while connecting, as it may result in an insecure fit.

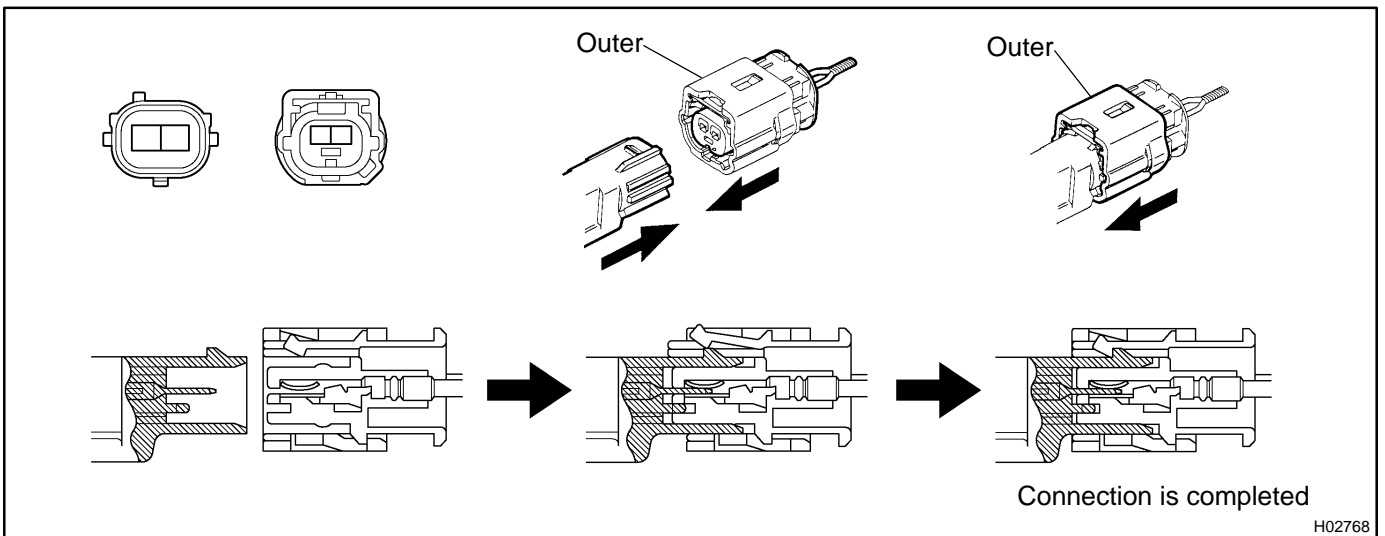

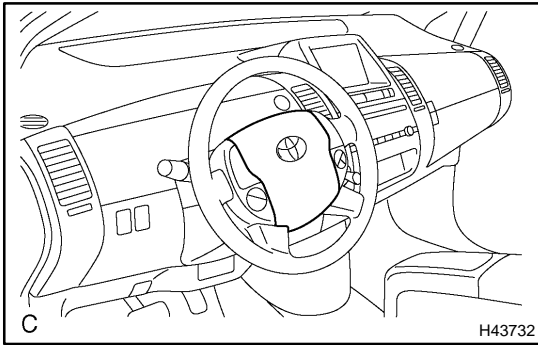

ON-VEHICLE INSPECTION

1. HORN BUTTON ASSY (VEHICLE NOT INVOLVED IN COLLISION)

- (a) Perform a diagnostic system check (see page 05-1402).
- (b) With the horn button assy installed on the vehicle, perform a visual check. If there are any defects as mentioned below, replace the horn button assy with a new one:
 - Cuts, minute cracks or marked discoloration on the horn button assy top surface or in the grooved portion.

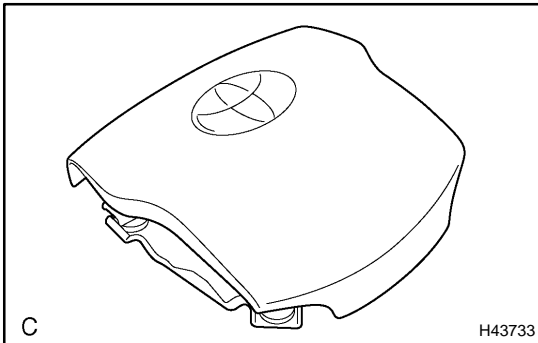

2. HORN BUTTON ASSY (VEHICLE INVOLVED IN COLLISION AND AIRBAG IS NOT DEPLOYED)

- (a) Perform a diagnostic system check (see page 05-1402).
- (b) With the horn button assy removed from the vehicle, perform a visual check. If there are any defects as mentioned below, replace the horn button assy or steering wheel assy with a new one:
 - Cuts, minute cracks or marked discoloration on the horn button assy top surface or in the grooved portion.
 - Cracks or other damage to the connectors.
 - Deformation of the steering wheel assy.

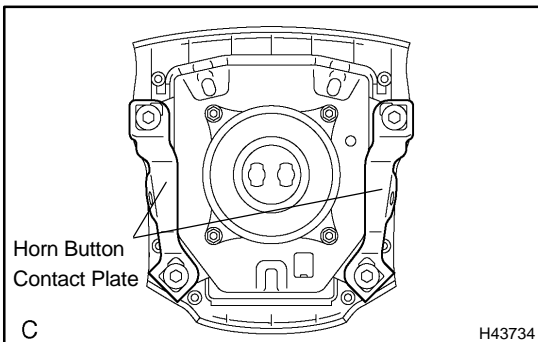

- Deformation of the horn button contact plate of the horn button assy.

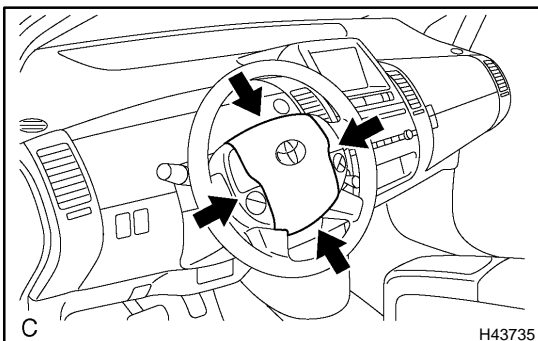

- There should be no interference between the horn button assy and steering wheel assy, and the clearance should be uniform all the way around when the new horn button assy is installed on the steering wheel assy.

CAUTION:

For removal and installation procedures of the horn button assy, see page 60-20, and be sure to follow the correct procedure.

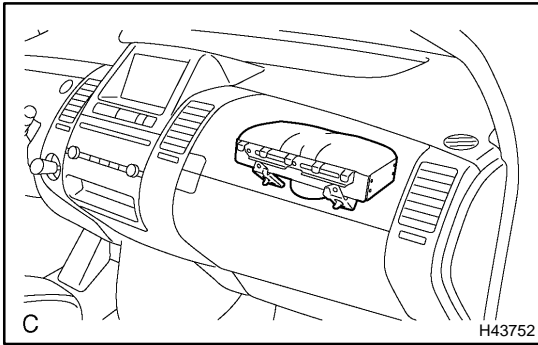

3. FRONT PASSENGER AIRBAG ASSY (VEHICLE NOT INVOLVED IN COLLISION)

- (a) Perform a diagnostic system check (see page 05-1402).
- (b) With the front passenger airbag assy installed on the vehicle, perform a visual check. If there are any defects as mentioned below, replace the instrument panel with a new one:

Cuts, minute cracks or marked discoloration on the instrument panel around the front passenger airbag assy.

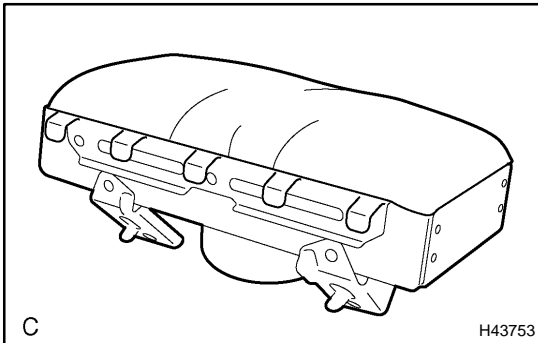

4. FRONT PASSENGER AIRBAG ASSY (VEHICLE INVOLVED IN COLLISION AND AIRBAG IS NOT DEPLOYED)

- (a) Perform a diagnostic system check (see page 05-1402).
- (b) With the front passenger airbag assy removed from the vehicle, perform a visual check. If there are any defects as mentioned below, replace the front passenger airbag assy, instrument panel or instrument panel reinforcement with a new one:

- Cuts, minute cracks or marked discoloration on the front passenger airbag assy.
 - Cracks or other damage to the connectors.
-
- Deformation or cracks on the instrument panel or instrument panel reinforcement.

CAUTION:

For removal and installation procedures of the front passenger airbag assy, see page 60-32, and be sure to follow the correct procedure.

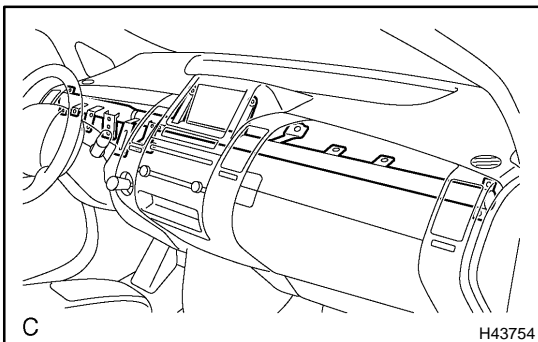

5. FRONT SEAT AIRBAG ASSY (VEHICLE NOT INVOLVED IN COLLISION)

- (a) Perform a diagnostic system check (see page 05-1402).
- (b) With the front seat airbag assy installed on the vehicle, perform a visual check. If there are any defects as mentioned below, replace the front seat back assy with a new one:

Cuts, minute cracks or marked discoloration on the front seat back assy around the front seat airbag assy.

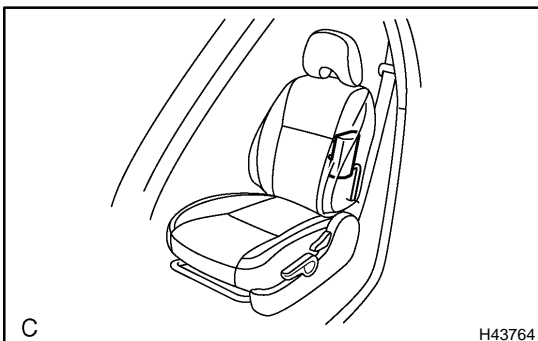

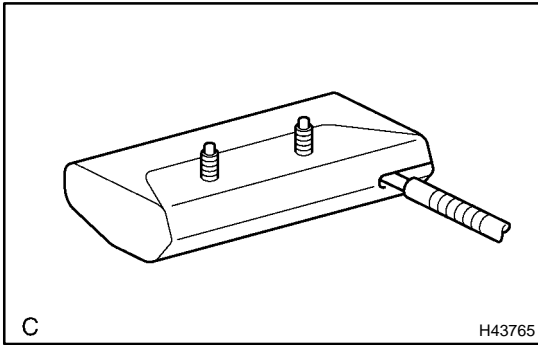

6. FRONT SEAT AIRBAG ASSY (VEHICLE INVOLVED IN COLLISION AND AIRBAG IS NOT DEPLOYED)

- (a) Perform a diagnostic system check (see page 05-1402).
- (b) With the front seat airbag assy removed from the vehicle, perform a visual check. If there are any defects as mentioned below, replace the front seat airbag assy with a new one:
 - Cuts, minute cracks or marked discoloration on the front seat airbag assy.
 - Cracks or other damage to the wire harness or connector.

CAUTION:

For removal and installation procedures of the front seat airbag assy, see page 72-2, and be sure to follow the correct procedure.

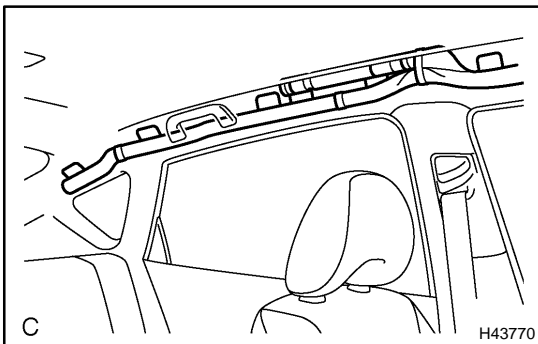

7. CURTAIN SHIELD AIRBAG ASSY (VEHICLE NOT INVOLVED IN COLLISION)

- (a) Perform a diagnostic system check (see page 05-1402).
- (b) With the curtain shield airbag assy installed on the vehicle, perform a visual check. If there are any defects as mentioned below, replace the front pillar garnish or roof headlining assy with a new one:
 - Cuts, minute cracks or marked discoloration on the front pillar garnish and roof headlining assy around the curtain shield airbag assy.

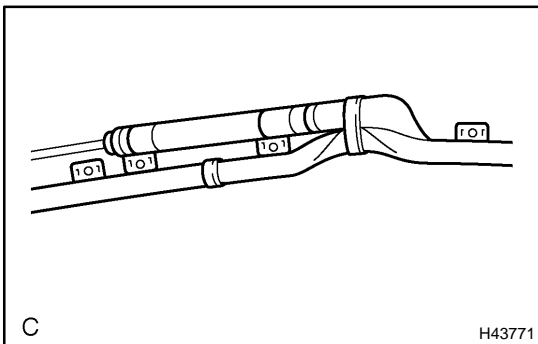

8. CURTAIN SHIELD AIRBAG ASSY (VEHICLE INVOLVED IN COLLISION AND AIRBAG IS NOT DEPLOYED)

- (a) Perform a diagnostic system check (see page 05-1402).
- (b) With the curtain shield airbag assy removed from the vehicle, perform a visual check. If there are any defects as mentioned below, replace the curtain shield airbag assy with a new one:
 - Cuts, minute cracks or marked discoloration on the curtain shield airbag assy.
 - Cracks or other damage to the connector.

CAUTION:

For removal and installation procedures of the curtain shield airbag assy, see page 60-41, and be sure to follow the correct procedure.

9. AIRBAG ECU ASSY (VEHICLE NOT INVOLVED IN COLLISION)

- (a) Perform a diagnostic system check (see page 05-1402).

10. AIRBAG ECU ASSY (VEHICLE INVOLVED IN COLLISION AND AIRBAG IS NOT DEPLOYED)

- (a) Perform a diagnostic system check (see page 05-1402).

11. AIRBAG ECU ASSY (VEHICLE INVOLVED IN COLLISION AND AIRBAG IS DEPLOYED)

- (a) Replace the airbag ECU assy.

CAUTION:

For removal and installation procedures of the airbag ECU assy, see page 60-54, and be sure to follow the correct procedure.

12. AIRBAG SENSOR FRONT (VEHICLE NOT INVOLVED IN COLLISION)

- (a) Perform a diagnostic system check (see page 05-1402).

13. AIRBAG SENSOR FRONT (VEHICLE INVOLVED IN COLLISION AND AIRBAG IS NOT DEPLOYED)

- (a) Perform a diagnostic system check (see page 05-1402).
- (b) When the front bumper of the vehicle or its periphery is damaged, check if there is any damage to the airbag sensor front. If there are any defects as mentioned below, replace the airbag sensor front with a new one:
- Cracks, dents or chips in the case.
 - Cracks or other damage to the connector.
 - Peeling off of the label or damage to the serial number.

CAUTION:

For removal and installation procedures of the airbag sensor front, see page 60-56, and be sure to follow the correct procedure.

14. AIRBAG SENSOR FRONT (VEHICLE INVOLVED IN COLLISION AND AIRBAG IS DEPLOYED)

- (a) Replace the airbag sensor front.

CAUTION:

For removal and installation procedures of the airbag sensor front, see page 60-56, and be sure to follow the correct procedure.

15. SIDE AIRBAG SENSOR ASSY (VEHICLE NOT INVOLVED IN COLLISION)

- (a) Perform a diagnostic system check (see page 05-1402).

16. SIDE AIRBAG SENSOR ASSY (VEHICLE INVOLVED IN COLLISION AND AIRBAG IS NOT DEPLOYED)

- (a) Perform a diagnostic system check (see page 05-1402).
- (b) When the center pillar of the vehicle or its periphery is damaged, check if there is any damage to the side airbag sensor assy. If there are any defects as mentioned below, replace the side airbag sensor assy with a new one:
- Cracks, dents or chips in the case.
 - Cracks or other damage to the connector.
 - Peeling off of the label or damage to the serial number.

CAUTION:

For removal and installation procedures of the side airbag sensor assy, see page 60-58, and be sure to follow the correct procedure.

17. SIDE AIRBAG SENSOR ASSY (VEHICLE INVOLVED IN COLLISION AND AIRBAG IS DEPLOYED)

- (a) Replace the side airbag sensor assy.

CAUTION:

For removal and installation procedures of the side airbag sensor assy, see page 60-58, and be sure to follow the correct procedure.

18. AIRBAG SENSOR REAR (VEHICLE NOT INVOLVED IN COLLISION)

- (a) Perform a diagnostic system check (see page 05-1402).

19. AIRBAG SENSOR REAR (VEHICLE INVOLVED IN COLLISION AND AIRBAG IS NOT DEPLOYED)

- (a) Perform a diagnostic system check (see page 05-1402).
- (b) When the quarter panel of the vehicle or its periphery is damaged, check if there is any damage to the airbag sensor rear. If there are any defects as mentioned below, replace the airbag sensor rear with a new one:
 - Cracks, dents or chips in the case.
 - Cracks or other damage to the connector.
 - Peeling off of the label or damage to the serial number.

CAUTION:

For removal and installation procedures of the airbag sensor rear, see page 60-60, and be sure to follow the correct procedure.

20. AIRBAG SENSOR REAR (VEHICLE INVOLVED IN COLLISION AND AIRBAG IS DEPLOYED)

- (a) Replace the airbag sensor rear.

CAUTION:

For removal and installation procedures of the airbag sensor rear, see page 60-60, and be sure to follow the correct procedure.

21. SEAT POSITION AIRBAG SENSOR (VEHICLE NOT INVOLVED IN COLLISION)

- (a) Perform a diagnostic system check (see page 05-1402).

22. SEAT POSITION AIRBAG SENSOR (VEHICLE INVOLVED IN COLLISION)

- (a) Perform a diagnostic system check (see page 05-1402).
- (b) Even if the airbag was not deployed, perform a visual check for damage to the seat position airbag sensor. If there are any defects as mentioned below, replace the seat position airbag sensor with a new one:
 - Cracks, dents or chips in the case.
 - Cracks or other damage to the connector.

CAUTION:

For removal and installation procedures of the seat position airbag sensor, see page 60-62, and be sure to follow the correct procedure.

23. WIRE HARNESS AND CONNECTOR (VEHICLE NOT INVOLVED IN COLLISION)

- (a) Perform a diagnostic system check (see page 05-1402).

24. WIRE HARNESS AND CONNECTOR (VEHICLE INVOLVED IN COLLISION)

- (a) Perform a diagnostic system check (see page 05-1402).
- (b) Check for breaks in all wires of the SRS wire harness and exposed conductors.
- (c) Check to see if the SRS wire harness connectors are cracked or chipped.

HINT:

The SRS wire harness is integrated with the engine room main wire, instrument panel wire, floor wire and floor wire No.2.

HORN BUTTON ASSY COMPONENTS

600KC-04

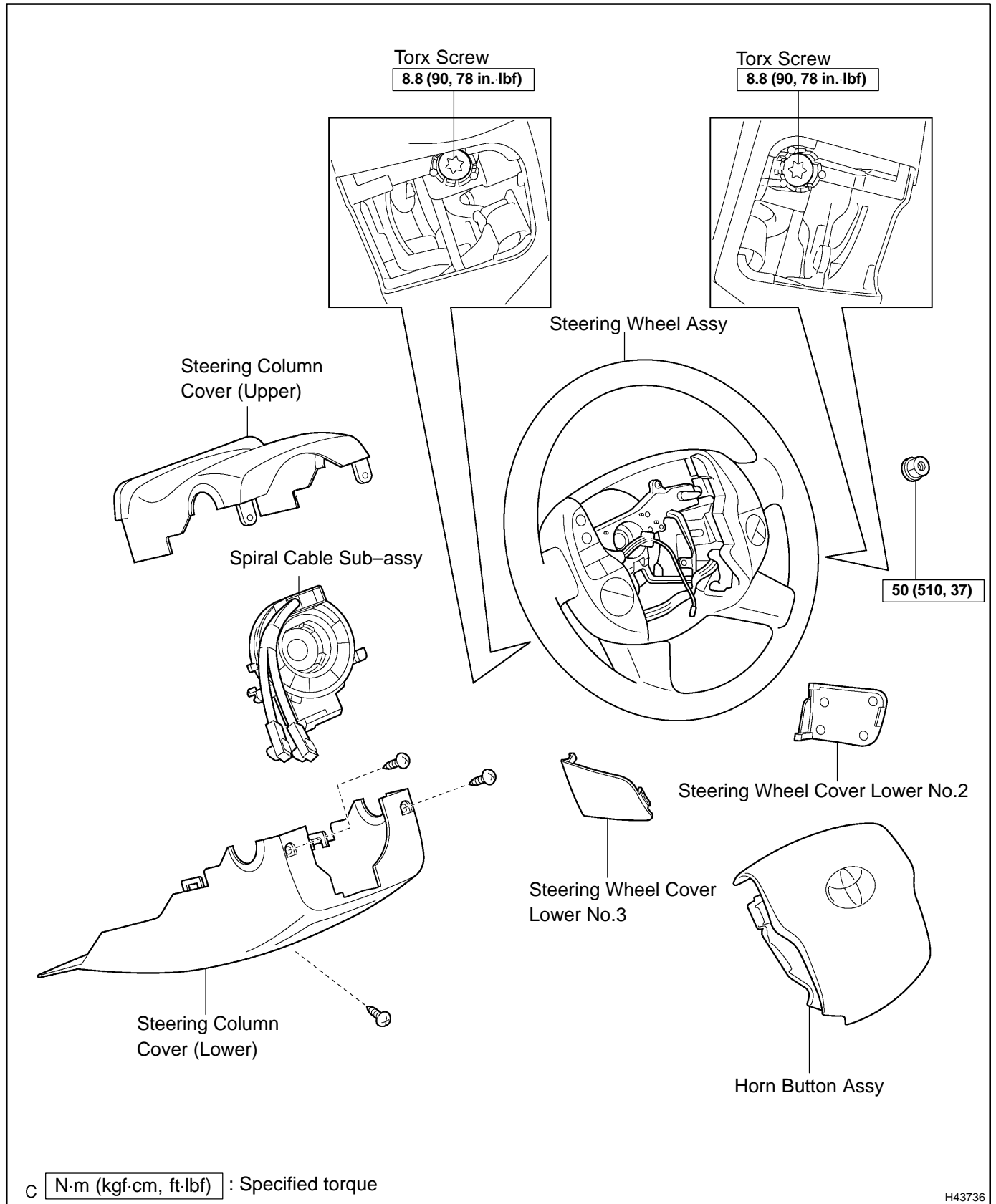

REPLACEMENT

HINT:

Installation is in the reverse order of removal.

1. **PRECAUTION (SEE PAGE 60-1)**
2. **DISCONNECT BATTERY NEGATIVE TERMINAL (SEE PAGE 60-1)**

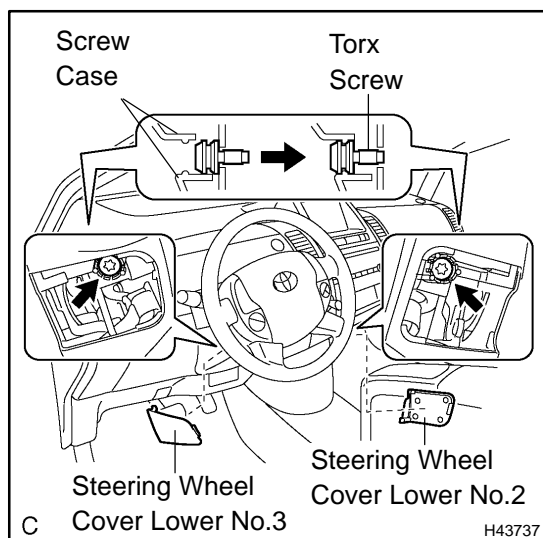

3. REMOVE STEERING WHEEL COVER LOWER NO.2

- (a) Using a screwdriver, remove the steering wheel cover lower No.2.

HINT:

Tape up the screwdriver tip before use.

4. REMOVE STEERING WHEEL COVER LOWER NO.3

- (a) Using a screwdriver, remove the steering wheel cover lower No.3.

HINT:

Tape up the screwdriver tip before use.

5. REMOVE HORN BUTTON ASSY

- (a) Place the front wheels facing straight ahead.
- (b) Using a torx socket wrench (T30), loosen the 2 torx screws until the groove along the screw circumference catches on the screw case.
- (c) Pull out the horn button assy from the steering wheel assy and support the horn button assy with one hand as shown in the illustration.

NOTICE:

When removing the horn button assy, do not pull the airbag wire harness.

- (d) Disconnect the horn connector.
- (e) Disconnect the connectors from the horn button assy.

NOTICE:

When handling the airbag connector, take care not to damage the airbag wire harness.

- (f) Remove the horn button assy.

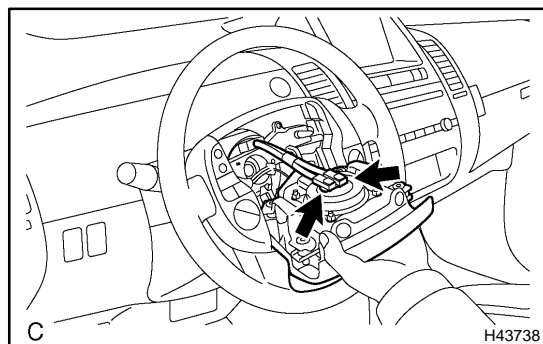

6. INSTALL HORN BUTTON ASSY

- (a) Support the horn button assy with one hand as shown in the illustration.
- (b) Connect the connectors to the horn button assy.

NOTICE:

When handling the airbag connector, take care not to damage the airbag wire harness.

- (c) Connect the horn connector.

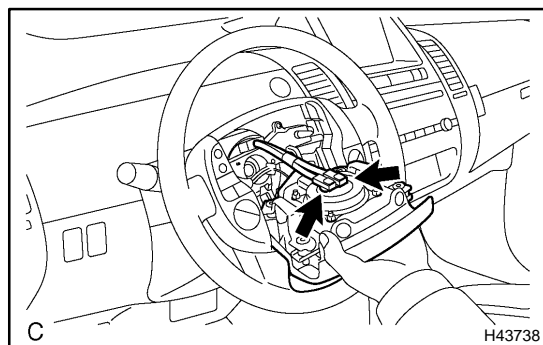

- (d) Confirm that the circumference groove of the torx screw fits in the screw case, and place the horn button assy onto the steering wheel assy.
- (e) Using a torx socket wrench (T30), tighten the 2 torx screws.

Torque: 8.8 N·m (90 kgf·cm, 78 in·lbf)

7. CONNECT BATTERY NEGATIVE TERMINAL

NOTICE:

When disconnecting the negative (-) battery terminal, initialize the following systems after the terminal is reconnected.

| System Name | See Page |
|-----------------------------|-----------------------|
| Power Window Control System | 01-28 |

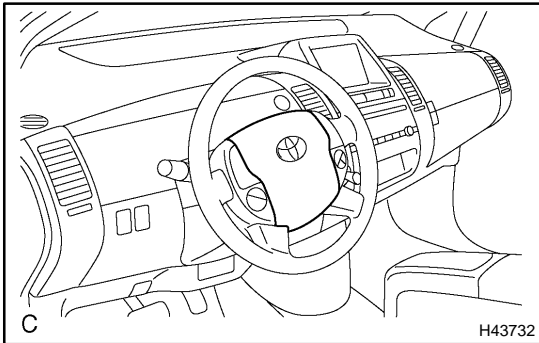

8. INSPECT HORN BUTTON ASSY

- (a) With the horn button assy installed on the vehicle, perform a visual check including the following:
Cuts, minute cracks or marked discoloration on the horn button assy top surface or in the grooved portion.
- (b) Make sure that the horn sounds.

HINT:

If the horn does not sound, inspect the horn system (see page [77-4](#)).

9. INSPECT SRS WARNING LIGHT (SEE PAGE [05-1397](#))

DISPOSAL

HINT:

When scrapping a vehicle equipped with the SRS or disposing of the horn button assy, be sure to deploy the airbag first in accordance with the procedure described below. If any abnormality occurs with the airbag deployment, contact the SERVICE DEPT. of TOYOTA MOTOR SALES, U.S.A., INC.

CAUTION:

- Never dispose of a horn button assy that has an undeployed airbag.
- The airbag produces an exploding sound when it is deployed, so perform the operation outdoors and where it will not create a nuisance to nearby residents.

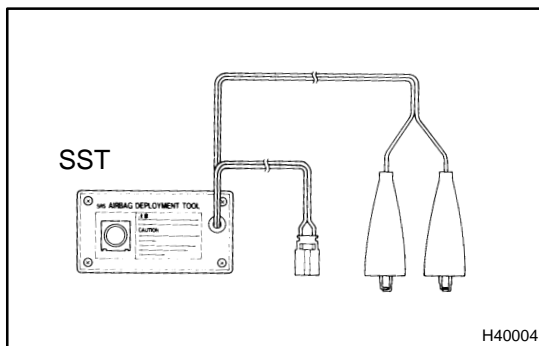

- When deploying the airbag, always use the specified SST (SRS Airbag Deployment Tool). Perform the operation in a place away from electrical noise.
- When deploying the airbag, perform the operation at least 10 m (33 ft) away from the horn button assy.
- The horn button assy becomes extremely hot when the airbag is deployed, so do not touch it for at least 30 minutes after deployment.
- Use gloves and safety glasses when handling a horn button assy with a deployed airbag.
- Do not apply water, etc. to a horn button assy with a deployed airbag.
- Always wash your hands with water after completing the operation.

1. DISPOSE OF HORN BUTTON ASSY (WHEN INSTALLED IN VEHICLE)

HINT:

Prepare a battery as the power source to deploy the airbag.

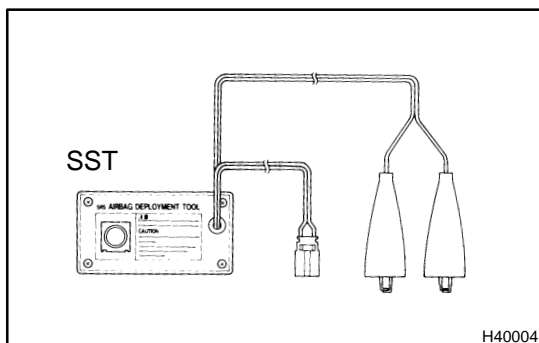

- (a) Check the function of the SST.

SST 09082-00700

CAUTION:

When deploying the airbag, always use the specified SST: SRS Airbag Deployment Tool.

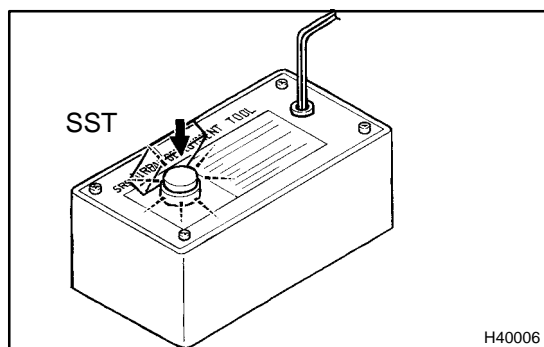
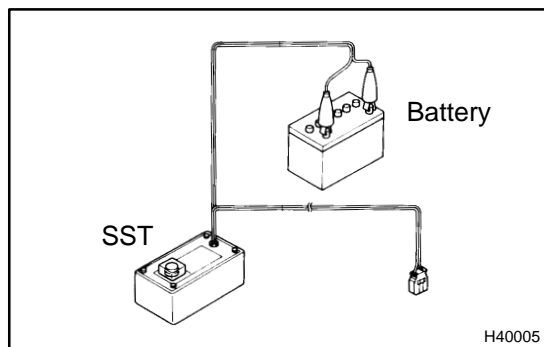

- (1) Connect the SST to the battery.
Connect the red clip of the SST to the battery positive (+) terminal and the black clip of the SST to the battery negative (-) terminal.

- (2) Check the function of the SST.
Press the SST activation switch, and check that the LED of the SST activation switch comes on.

CAUTION:

- Do not connect the SST connector (yellow colored one) to the airbag.
- If the LED comes on when the activation switch is not pressed, SST malfunction is possible, so be sure not to use the SST.

- (3) Disconnect the SST from the battery.

(b) Precaution (see page 60-1).

(c) Disconnect the battery negative terminal (see page 60-1).

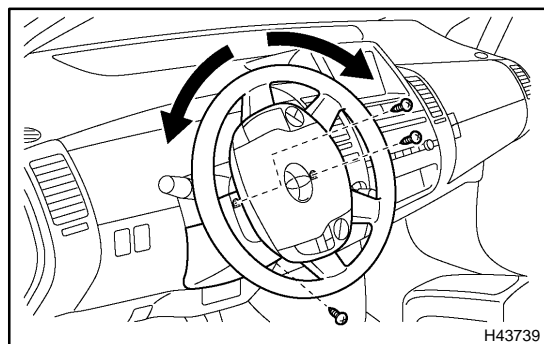

- (d) Remove the steering column cover (lower).

- (1) While turning the steering wheel assy to the right and left, remove the 3 screws and steering column cover (lower).

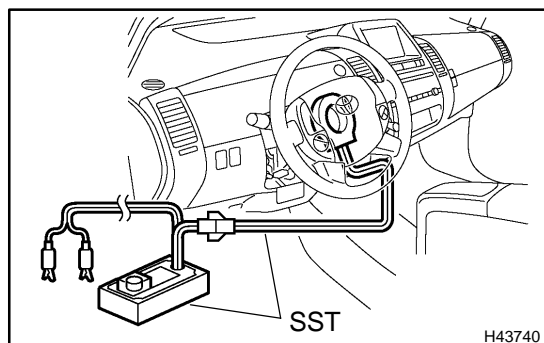

- (e) Install the SST.

CAUTION:

Check that there is no looseness in the steering wheel assy and horn button assy.

- (1) Disconnect the airbag connector (yellow colored one) from the spiral cable sub-assy.

NOTICE:

When handling the airbag connector, take care not to damage the airbag wire harness.

- (2) Connect the SST connector to the airbag connector of the spiral cable sub-assy.

SST 09082-00700, 09082-00780

NOTICE:

To avoid damaging the SST connector and wire harness, do not lock the secondary lock of the twin lock.

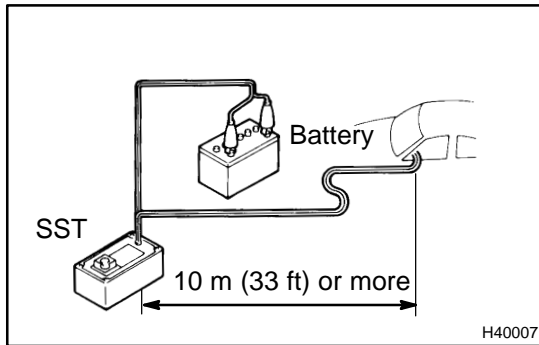

- (3) Move the SST at least 10 m (33 ft) away from the vehicle front side window.
- (4) Maintaining enough clearance for the SST wire harness in the front side window, close all doors and windows of the vehicle.

NOTICE:

Take care not to damage the SST wire harness.

- (5) Connect the red clip of the SST to the battery positive (+) terminal and the black clip of the SST to the negative (-) terminal.
- (f) Deploy the airbag.
 - (1) Check that no one is inside the vehicle or within a 10 m (33 ft) radius of the vehicle.
 - (2) Press the SST activation switch and deploy the airbag.

CAUTION:

- **When deploying the airbag, make sure that no one is near the vehicle.**
- **The horn button assy becomes extremely hot when the airbag is deployed, so do not touch it for at least 30 minutes after deployment.**
- **Use gloves and safety glasses when handling a horn button assy with a deployed airbag.**
- **Always wash your hands with water after completing the operation.**
- **Do not apply water, etc. to a horn button assy with a deployed airbag.**

HINT:

The airbag is deployed as the LED of the SST activation switch comes on.

2. DISPOSE OF HORN BUTTON ASSY (WHEN NOT INSTALLED IN VEHICLE)

NOTICE:

- **When disposing of the horn button assy, never use the customer's vehicle to deploy the airbag.**
- **Be sure to follow the procedure detailed below when deploying the airbag.**

HINT:

Prepare a battery as the power source to deploy the airbag.

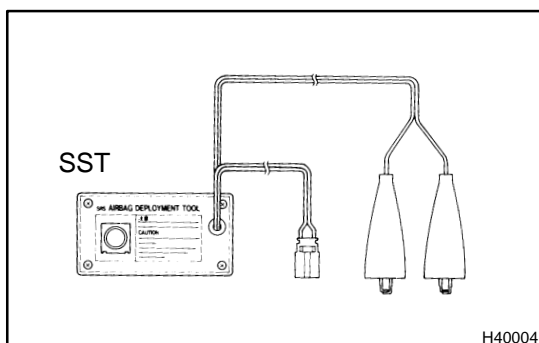

- (a) Check the function of the SST (see step 1-(a)).
- (b) Remove the horn button assy (see page 60-20).

CAUTION:

- **When removing the horn button assy, work must be started 90 seconds after the power switch is turned off and the negative (-) terminal cable is disconnected from the battery.**
- **When storing the horn button assy, keep the upper surface of the airbag deployment side facing upward.**

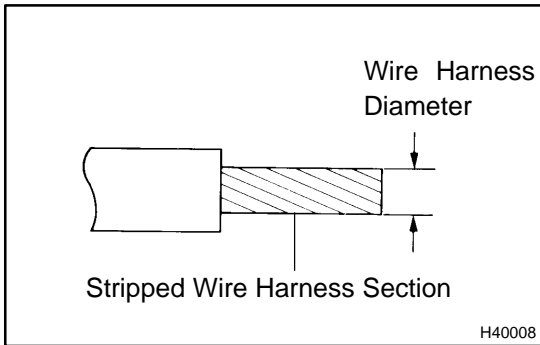

- (c) Using a service-purpose wire harness for the vehicle, tie down the horn button assy to the disc wheel.
Wire harness: Stripped wire harness section 1.25 mm² or more (0.0019 in². or more)

CAUTION:

If the wire harness is too thin or an alternative object is used to tie down the horn button assy, it may be snapped by the shock when the airbag is deployed. Always use a wire harness for vehicle use with an area of at least 1.25 mm² (0.0019 in²).

HINT:

To calculate the area of the stripped wire harness section:

$$\text{Area} = 3.14 \times (\text{Diameter})^2 \text{ divided by } 4$$

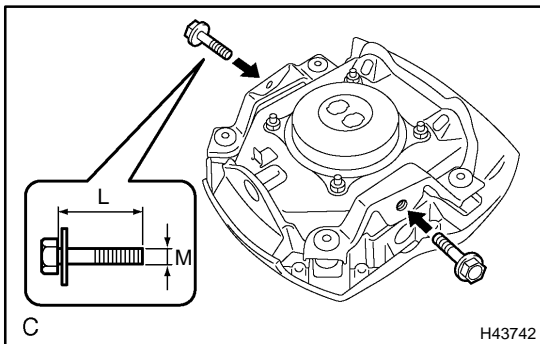

- (1) Install the 2 bolts with washers into the 2 bolt holes on the horn button assy.

Bolt:

L: 35.0 mm (1.378 in.)

M: 6.0 mm (0.236 in.)

Pitch: 1.0 mm (0.039 in.)

NOTICE:

- Tighten the bolts by hand until they become difficult to turn.
- Do not tighten the bolts excessively.

- (2) After connecting the SST below to each other, connect them to the horn button assy.

SST 09082-00802 (09082-10801, 09082-30801)

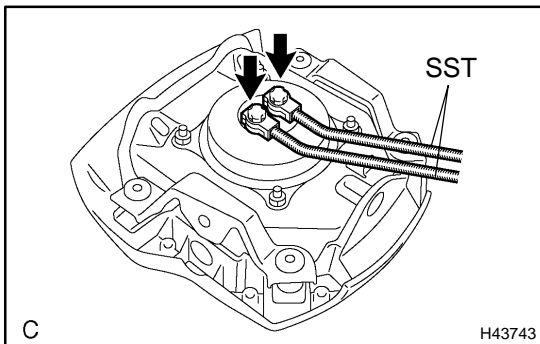

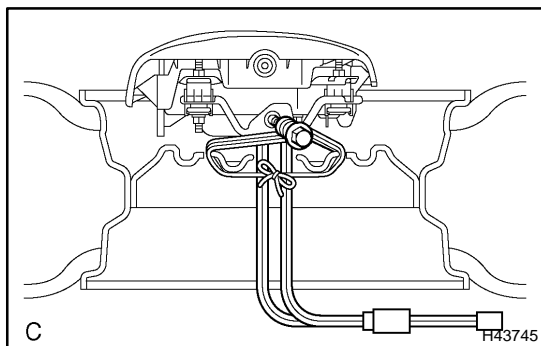
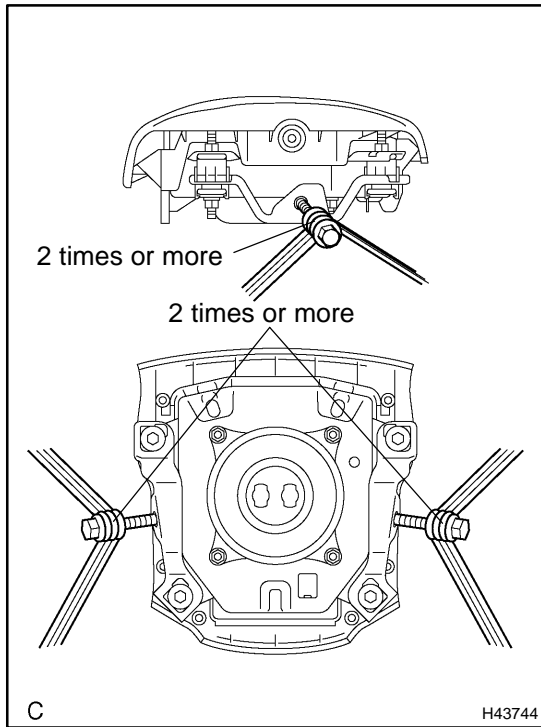

- (3) Using 3 wire harnesses, wind wire harness at least 2 times each around the bolts installed on the left and right sides of the horn button assy.

CAUTION:

- **Tightly wind the wire harness around the bolts so that there is no slack.**
- **Make sure that the wire harness is tight. If there is slack in wire harness, the horn button assy may become loose due to the shock when the airbag is deployed.**

- (4) Face the airbag deployment side of the horn button assy upward. Separately tie the left and right sides of the horn button assy to the disc wheel through the hub nut holes. Position the SST connector so that it hangs downward through the hub hole in the disc wheel.

CAUTION:

- **Make sure that the wire harness is tight. If there is slack in wire harness, the horn button assy may become loose due to the shock when the airbag is deployed.**
- **Always tie down the horn button assy with the airbag deployment side facing upward. It is highly dangerous if the horn button assy is tied down with the airbag deployment side facing downward as the wire harness will be cut by the shock caused by the airbag deployment and the horn button assy will be thrown into the air.**

NOTICE:

The disc wheel will be marked by the airbag deployment, so use an extra disc wheel.

SUPPLEMENTAL RESTRAINT SYSTEM - HORN BUTTON ASSY

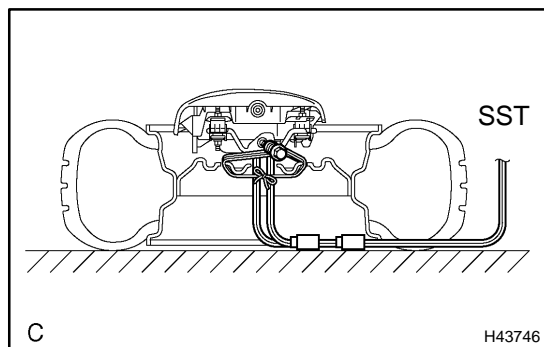

(d) Install the SST.

CAUTION:

Place the disc wheel on the level ground.

(1) Connect the SST connector.

SST 09082-00700

NOTICE:

To avoid damaging the SST connector and wire harness, do not lock the secondary lock of the twin lock. Also, secure some slack for the SST wire harness inside the disc wheel.

(2) Move the SST at least 10 m (33 ft) away from the horn button assy tied down to the disc wheel.

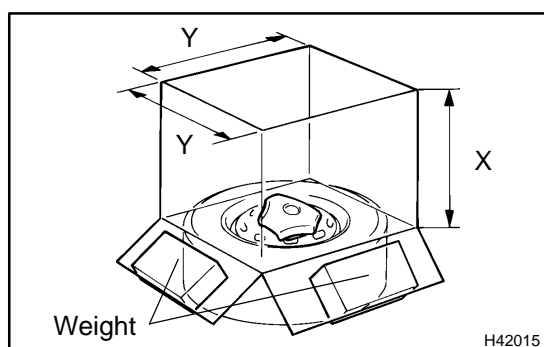
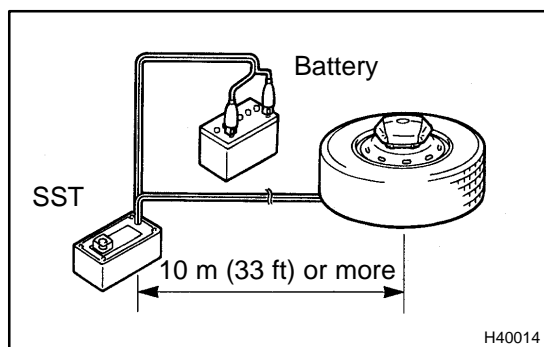

(e) Cover the horn button assy with a cardboard box or tires.

(1) Covering method using a cardboard box:

Cover the horn button assy with the cardboard box and place the weights on the cardboard box in 4 places with at least 190 N (19 kg, 43 lb).

Cardboard box size: Must exceed the following dimensions

X = 460 mm (18.11 in.)

Y = 650 mm (25.59 in.)

NOTICE:

- When dimension Y of the cardboard box exceeds the diameter of the disc wheel with tire which the horn button assy is tied to, X should be the following size.
X = 460 mm (18.11 in.) + width of tire
- If a cardboard box which is smaller than the specified size is used, the cardboard box will be broken by the shock from the airbag deployment.

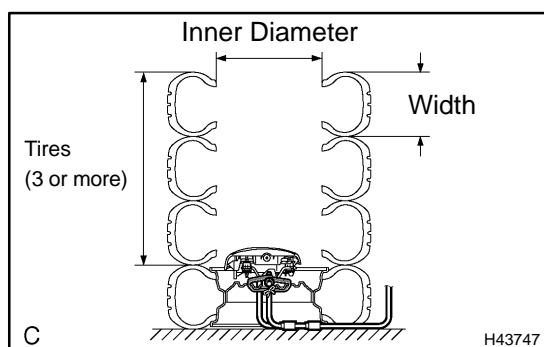

(2) Covering method using tires:

Place at least 3 tires without disc wheels on top of the tire with disc wheel which the horn button assy is tied to.

Tire size: Must exceed the following dimensions

Width: 185 mm (7.28 in.)

Inner diameter: 360 mm (14.17 in.)

CAUTION:

Do not use tires with disc wheels.

NOTICE:

- The tires may be marked by the airbag deployment, so use an extra tire.
 - Do not place the SST connector under the tire because it could be damaged.
- (3) Tie the tires together with 2 wire harnesses.

CAUTION:

Make sure that the wire harness is tight. It is highly dangerous when looseness in the wire harness results in the tires coming free due to the shock when the airbag is deployed.

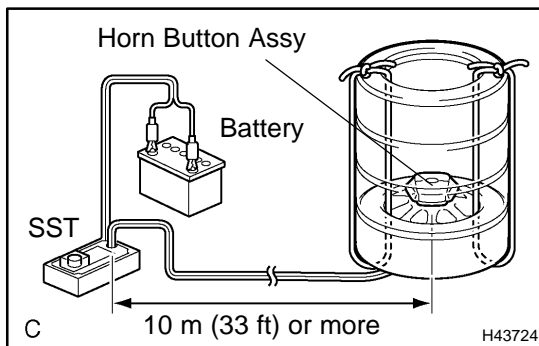
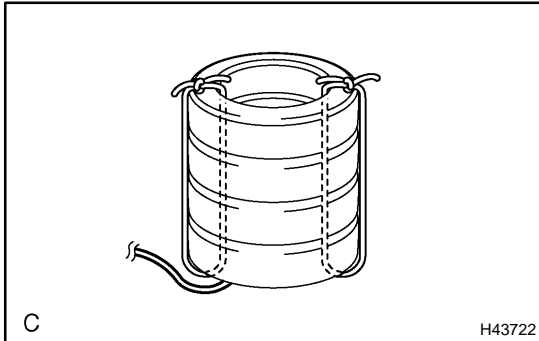

(f) Deploy the airbag.

- (1) Connect the red clip of the SST to the battery positive (+) terminal and the black clip of the SST to the battery negative (-) terminal.
- (2) Check that no one is within a 10 m (33 ft) radius of the disc wheel which the horn button assy is tied to.
- (3) Press the SST activation switch and deploy the airbag.

CAUTION:

When deploying the airbag, make sure that no one is near the tire.

HINT:

The airbag is deployed as the LED of the SST activation switch comes on.



(g) Dispose of the horn button assy.

CAUTION:

- The horn button assy becomes extremely hot when the airbag is deployed, so do not touch it for at least 30 minutes after deployment.
 - Use gloves and safety glasses when handling a horn button assy with a deployed airbag.
 - Do not apply water, etc. to a horn button assy with a deployed airbag.
 - Always wash your hands with water after completing the operation.
- (1) Remove the horn button assy from the disc wheel.
 - (2) Place the horn button assy in a plastic bag, tie it tightly and dispose of it as other general parts disposal.

SPIRAL CABLE SUB-ASSY REPLACEMENT

600RI-01

HINT:

- COMPONENTS: See page 60-19.
 - Installation is in the reverse order of removal.
1. **PRECAUTION (SEE PAGE 60-1)**
 2. **DISCONNECT BATTERY NEGATIVE TERMINAL (SEE PAGE 60-1)**
 3. **PLACE FRONT WHEELS FACING STRAIGHT AHEAD**
 4. **REMOVE STEERING WHEEL COVER LOWER NO.2 (SEE PAGE 60-20)**
 5. **REMOVE STEERING WHEEL COVER LOWER NO.3 (SEE PAGE 60-20)**
 6. **REMOVE HORN BUTTON ASSY (SEE PAGE 60-20)**
 7. **REMOVE STEERING WHEEL ASSY (SEE PAGE 50-8)**
SST 09950-50013 (09951-05010, 09952-05010, 09953-05020, 09954-05021)
 8. **REMOVE STEERING COLUMN COVER (SEE PAGE 50-8)**

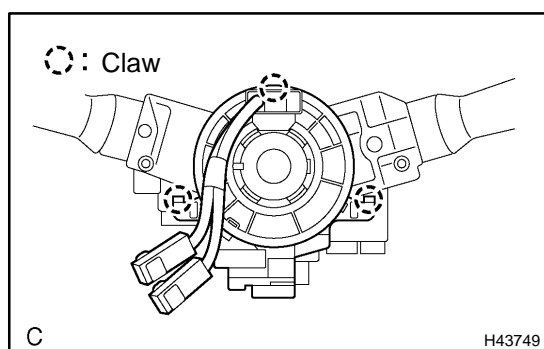

9. REMOVE SPIRAL CABLE SUB-ASSY

- (a) Disconnect the connectors from the spiral cable sub-assy.

NOTICE:

When handling the airbag connector, take care not to damage the airbag wire harness.

- (b) Disengage the 3 claws and remove the spiral cable sub-assy.

10. INSPECT SPIRAL CABLE SUB-ASSY

- (a) If any of the following conditions occur, replace the spiral cable sub-assy with a new one.

Condition:

Scratches or cracks on the connector

Cracks, dents or chips in the spiral cable sub-assy

11. INSTALL SPIRAL CABLE SUB-ASSY

- (a) Check that the front wheels are facing straight ahead.
- (b) Set the turn signal switch to the neutral position.

NOTICE:

Make sure that the turn signal switch is in the neutral position or the pin of the turn signal switch may be snapped.

- (c) Install the spiral cable sub-assy.

NOTICE:

When replacing the spiral cable sub-assy with a new one, remove the lock pin before installing the steering wheel assy.

- (d) Connect the connectors to the spiral cable sub-assy.

NOTICE:

When handling the airbag connector, take care not to damage the airbag wire harness.

12. INSTALL STEERING COLUMN COVER (SEE PAGE 50-8)

13. ADJUST SPIRAL CABLE SUB-ASSY

- (a) Check that the power switch is off.
- (b) Check that the battery negative (-) terminal is disconnected.

CAUTION:

After removing the terminal, wait for at least 90 seconds before starting the operation.

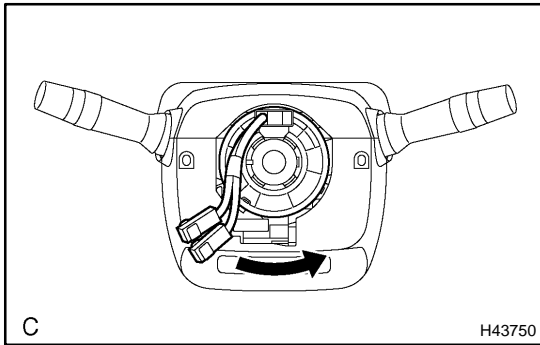

- (c) Turn the spiral cable sub-assy counterclockwise slowly by hand until it feels firm.

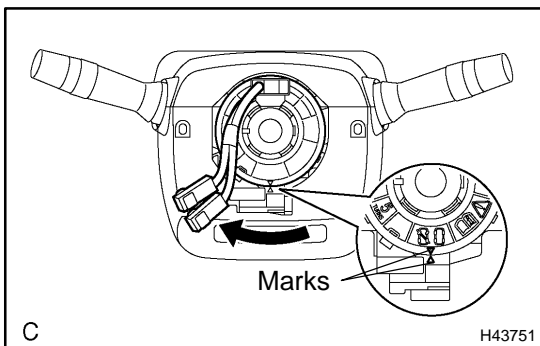

- (d) Rotate the spiral cable sub-assy clockwise approximately 2.5 turns to align the marks.

HINT:

The spiral cable sub-assy will rotate approximately 2.5 turns to both left and right of the center.

14. INSTALL STEERING WHEEL ASSY (SEE PAGE 50-8)

15. INSPECT STEERING WHEEL CENTER POINT

16. INSTALL HORN BUTTON ASSY (SEE PAGE 60-20)

17. CONNECT BATTERY NEGATIVE TERMINAL

NOTICE:

When disconnecting the negative (-) battery terminal, initialize the following systems after the terminal is reconnected.

| System Name | See Page |
|-----------------------------|----------|
| Power Window Control System | 01-28 |

18. INSPECT HORN BUTTON ASSY (SEE PAGE 60-14)

19. INSPECT SRS WARNING LIGHT (SEE PAGE 05-1397)

FRONT PASSENGER AIRBAG ASSY COMPONENTS

600RJ-01

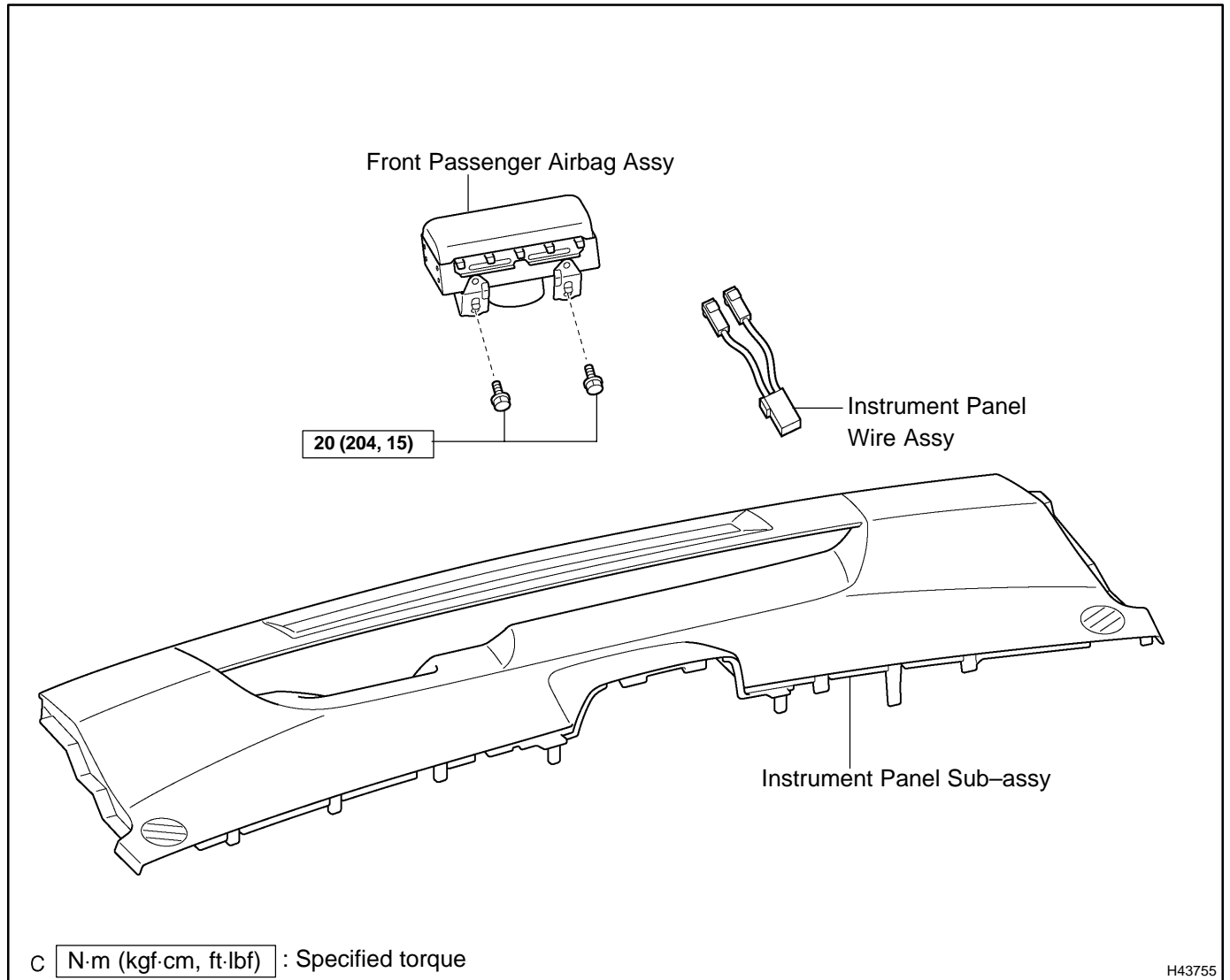

REPLACEMENT

HINT:

Installation is in the reverse order of removal.

1. **PRECAUTION (SEE PAGE 60-1)**
2. **DISCONNECT BATTERY NEGATIVE TERMINAL (SEE PAGE 60-1)**
3. **REMOVE GLOVE COMPARTMENT DOOR (SEE PAGE 71-7)**

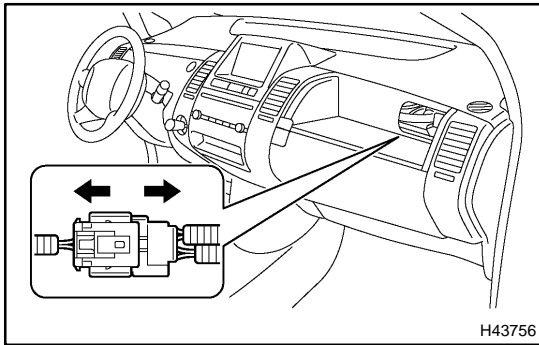

4. DISCONNECT FRONT PASSENGER AIRBAG ASSY CONNECTOR

- (a) Disconnect the connector.

NOTICE:

When handling the airbag connector, take care not to damage the airbag wire harness.

5. **REMOVE INSTRUMENT PANEL SUB-ASSY W/PASSENGER AIRBAG ASSY (SEE PAGE 71-7)**

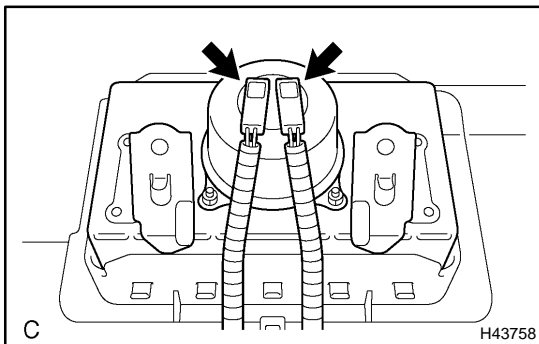

6. DISCONNECT INSTRUMENT PANEL WIRE ASSY

- (a) Disconnect the connectors from the front passenger airbag assy.

NOTICE:

When handling the airbag connector, take care not to damage the airbag wire harness.

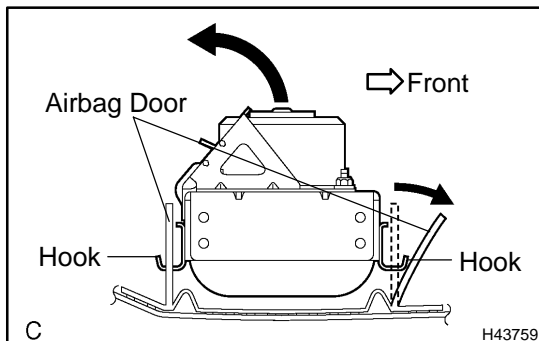

7. REMOVE FRONT PASSENGER AIRBAG ASSY

- (a) Release the front side wall of the airbag door from the hook by slightly deflecting it and roll the front passenger airbag assy rearward.
- (b) Release the rear side wall of the airbag door from the other hook and remove the front passenger airbag assy.

8. **INSPECT FRONT PASSENGER AIRBAG ASSY (SEE PAGE 60-14)**
9. **INSTALL FRONT PASSENGER AIRBAG ASSY**

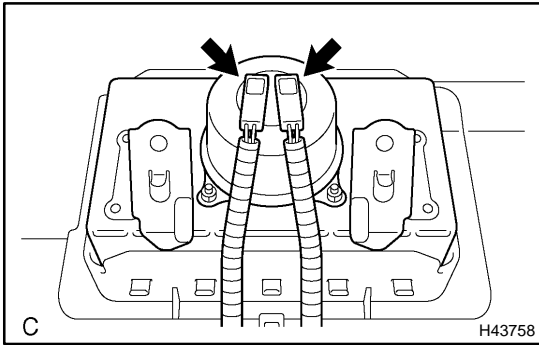

10. CONNECT INSTRUMENT PANEL WIRE ASSY

- (a) Connect the connectors to the front passenger airbag assy.

NOTICE:

When handling the airbag connector, take care not to damage the airbag wire harness.

11. INSTALL INSTRUMENT PANEL SUB-ASSY W/PASSENGER AIRBAG ASSY (SEE PAGE 71-7)

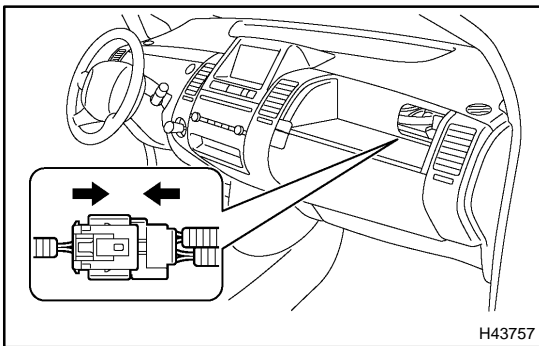

12. CONNECT FRONT PASSENGER AIRBAG ASSY CONNECTOR

- (a) Connect the connector.

NOTICE:

When handling the airbag connector, take care not to damage the airbag wire harness.

13. CONNECT BATTERY NEGATIVE TERMINAL

NOTICE:

When disconnecting the negative (-) battery terminal, initialize the following systems after the terminal is reconnected.

| System Name | See Page |
|-----------------------------|----------|
| Power Window Control System | 01-28 |

14. INSPECT SRS WARNING LIGHT (SEE PAGE 05-1397)

DISPOSAL

HINT:

When scrapping a vehicle equipped with the SRS or disposing of the front passenger airbag assy, be sure to deploy the airbag first in accordance with the procedure described below. If any abnormality occurs with the airbag deployment, contact the SERVICE DEPT. of TOYOTA MOTOR SALES, U.S.A., INC.

CAUTION:

- Never dispose of a front passenger airbag assy that has an undeployed airbag.
- The airbag produces an exploding sound when it is deployed, so perform the operation outdoors and where it will not create a nuisance to nearby residents.

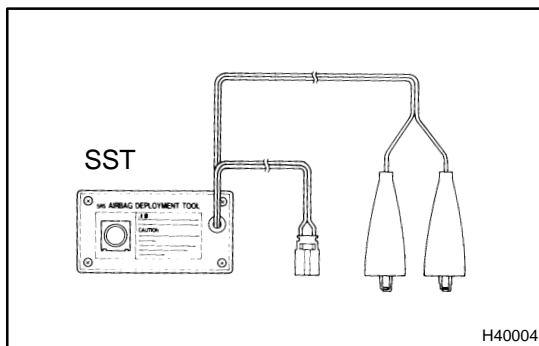

- When deploying the airbag, always use the specified SST (SRS Airbag Deployment Tool). Perform the operation in a place away from electrical noise.
 - When deploying the airbag, perform the operation at least 10 m (33 ft) away from the front passenger airbag assy.
 - The front passenger airbag assy becomes extremely hot when the airbag is deployed, so do not touch it for at least 30 minutes after deployment.
 - Use gloves and safety glasses when handling a front passenger airbag assy with a deployed airbag.
 - Do not apply water, etc. to a front passenger airbag assy with a deployed airbag.
 - Always wash your hands with water after completing the operation.
1. **DISPOSE OF FRONT PASSENGER AIRBAG ASSY (WHEN INSTALLED IN VEHICLE)**

HINT:

Prepare a battery as the power source to deploy the airbag.

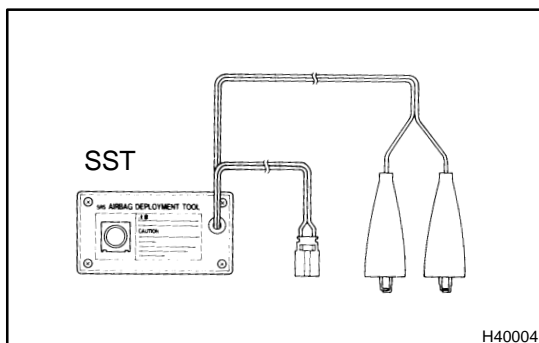

- (a) Check the function of the SST (see step 1-(a) on page 60-22).
- (b) Precaution (see page 60-1).
- (c) Disconnect the battery negative terminal (see page 60-1).
- (d) Remove the glove compartment door (see page 71-7).

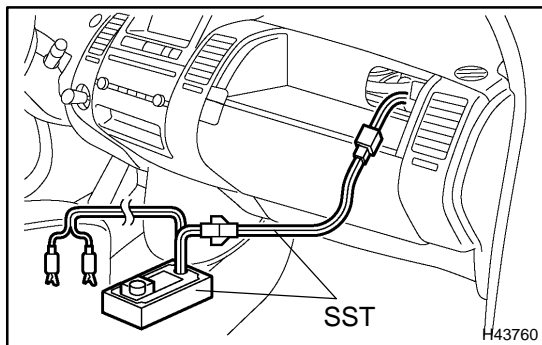

- (e) Install the SST.
- (1) Disconnect the connector from the front passenger airbag assy.

NOTICE:

When handling the airbag connector, take care not to damage the airbag wire harness.

- (2) Connect the SST connector to the front passenger airbag assy.

SST 09082-00700, 09082-00780

NOTICE:

To avoid damaging the SST connector and wire harness, do not lock the secondary lock of the twin lock.

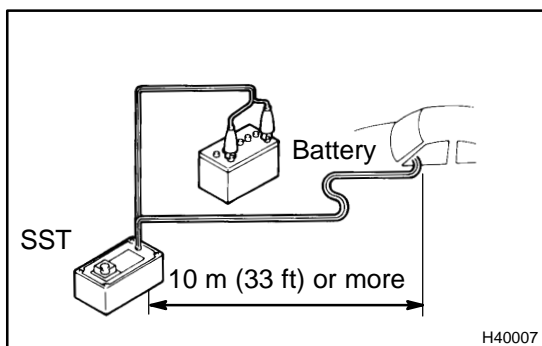

- (3) Move the SST at least 10 m (33 ft) away from the vehicle front side window.
- (4) Maintaining enough clearance for the SST wire harness in the front side window, close all doors and windows of the vehicle.

NOTICE:

Take care not to damage the SST wire harness.

- (5) Connect the red clip of the SST to the battery positive (+) terminal and the black clip of the SST to the negative (-) terminal.

- (f) Deploy the airbag.

- (1) Check that no one is inside the vehicle or within a 10 m (33 ft) radius of the vehicle.
- (2) Press the SST activation switch and deploy the airbag.

CAUTION:

- **When deploying the airbag, make sure that no one is near the vehicle.**
- **The front passenger airbag assy becomes extremely hot when the airbag is deployed, so do not touch it for at least 30 minutes after deployment.**
- **Use gloves and safety glasses when handling a front passenger airbag assy with a deployed airbag.**
- **Do not apply water, etc. to a front passenger airbag assy with a deployed airbag.**
- **Always wash your hands with water after completing the operation.**

HINT:

The airbag is deployed as the LED of the SST activation switch comes on.

2. DISPOSE OF FRONT PASSENGER AIRBAG ASSY (WHEN NOT INSTALLED IN VEHICLE)

NOTICE:

- When disposing of the front passenger airbag assy, never use the customer's vehicle to deploy the airbag.
- Be sure to follow the procedure detailed below when deploying the airbag.

HINT:

Prepare a battery as the power source to deploy the airbag.

- Check the function of the SST (see step 1-(a) on page 60-22).
- Remove the front passenger airbag assy (see page 60-32).

CAUTION:

- When removing the front passenger airbag assy, work must be started 90 seconds after the power switch is turned off and the negative (-) terminal cable is disconnected from the battery.
- When storing the front passenger airbag assy, keep the upper surface of the airbag deployment side facing upward.

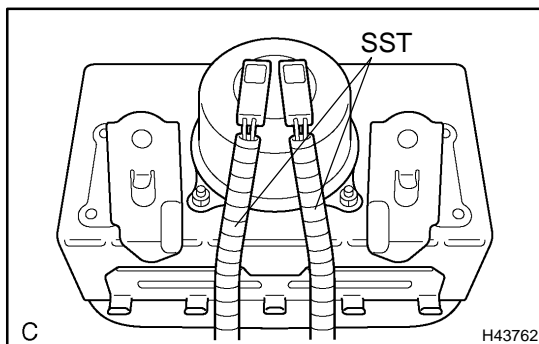
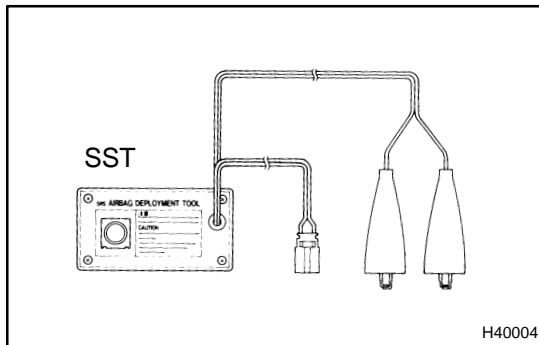

- Install the SST.
After connecting the SST below to each other, connect them to the front passenger airbag assy.
SST 09082-00802 (09082-10801, 09082-30801)

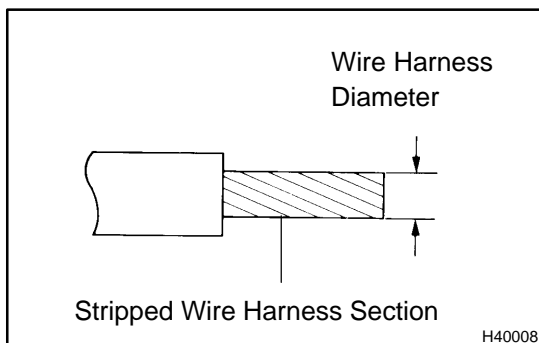

- Using a service-purpose wire harness for the vehicle, tie down the front passenger airbag assy to the tire.
Wire harness: Stripped wire harness section 1.25 mm² or more (0.0019 in.² or more)

CAUTION:

If the wire harness is too thin or an alternative object is used to tie down the front passenger airbag assy, it may be snapped by the shock when the airbag is deployed. Always use a wire harness for vehicle use with an area of at least 1.25 mm² (0.0019 in²).

HINT:

- To calculate the area of the stripped wire harness section:
Area = 3.14 x (Diameter)² divided by 4

- (1) Position the front passenger airbag assy inside the tire as shown in the illustration.

Tire size: Must exceed the following dimensions

Width: 185 mm (7.28 in.)

Inner diameter: 360 mm (14.17 in.)

CAUTION:

- Make sure that the wire harness is tight. If there is slack in wire harness, the front passenger airbag assy may become loose due to the shock when the airbag is deployed.
- Always tie down the front passenger airbag assy with the airbag deployment side facing inside the tire.

NOTICE:

The tire will be marked by the airbag deployment, so use an extra tire.

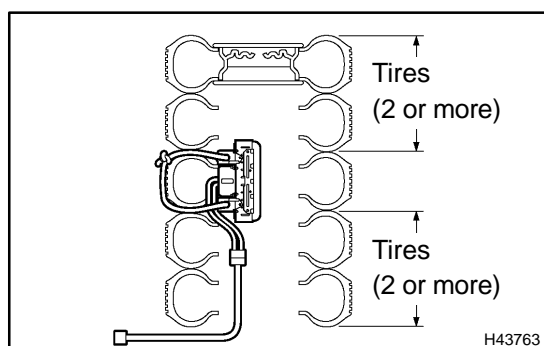
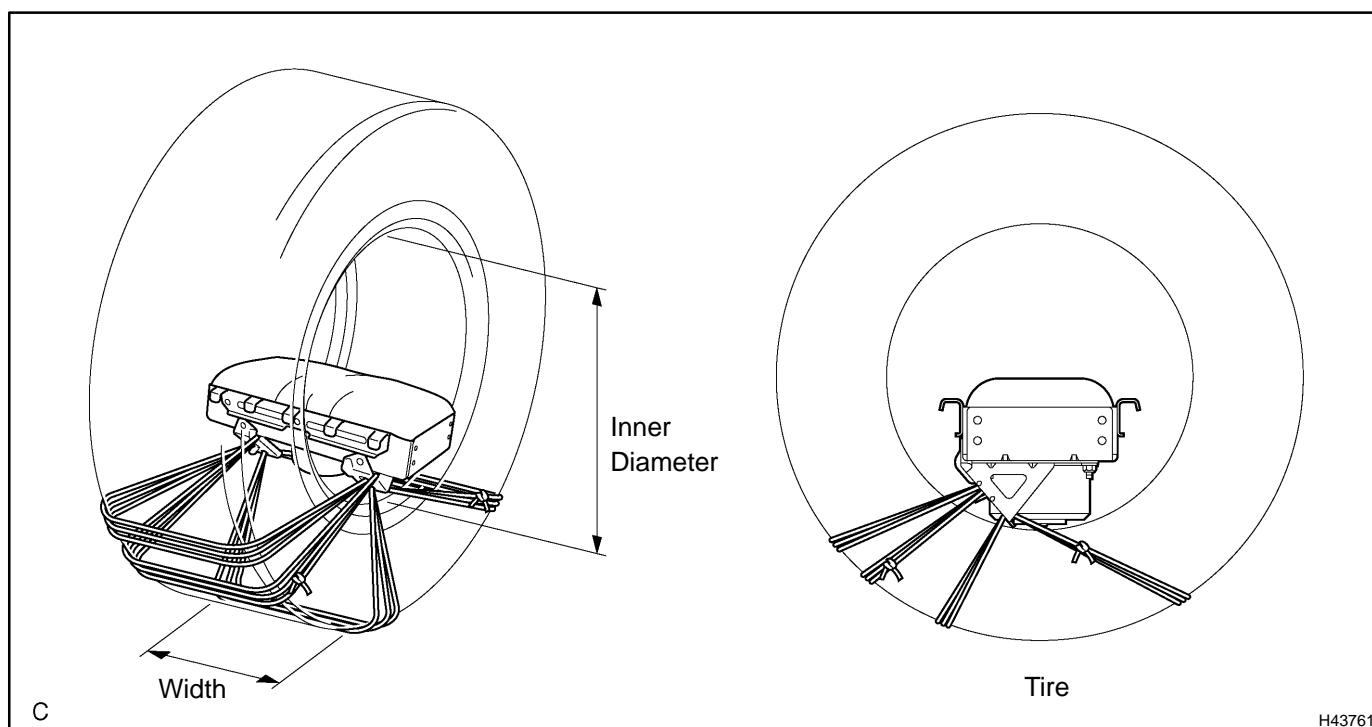

- (e) Place the tires.

- (1) Place at least 2 tires under the tire which the front passenger airbag assy is tied to.
- (2) Place at least 2 tires over the tire which the front passenger airbag assy is tied to. The top tire should have the disc wheel installed.

NOTICE:

Do not place the SST connector under the tire because it could be damaged.

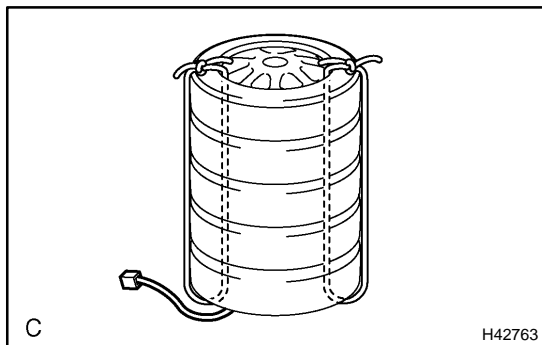

- (3) Tie the tires together with 2 wire harnesses.

CAUTION:

Make sure that the wire harness is tight. It is highly dangerous when looseness in the wire harness results in the tires coming free due to the shock when the airbag is deployed.

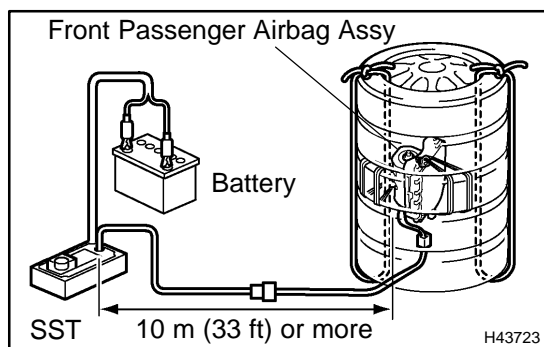

- (f) Install the SST.
Connect the SST connector.
SST 09082-00700

NOTICE:

To avoid damaging the SST connector and wire harness, do not lock the secondary lock of the twin lock. Also, secure some slack for the SST wire harness inside the tire.

- (g) Deploy the airbag.
- (1) Connect the red clip of the SST to the battery positive (+) terminal and the black clip of the SST to the battery negative (-) terminal.
 - (2) Check that no one is within a 10 m (33 ft) radius of the tire which the front passenger airbag assy is tied to.
 - (3) Press the SST activation switch and deploy the airbag.

CAUTION:

When deploying the airbag, make sure that no one is near the tire.

HINT:

The airbag is deployed as the LED of the SST activation switch comes on.



(h) Dispose of the front passenger airbag assy.

CAUTION:

- **The front passenger airbag assy becomes extremely hot when the airbag is deployed, so do not touch it for at least 30 minutes after deployment.**
- **Use gloves and safety glasses when handling a front passenger airbag assy with a deployed airbag.**
- **Do not apply water, etc. to a front passenger airbag assy with a deployed airbag.**
- **Always wash your hands with water after completing the operation.**
 - (1) Remove the front passenger airbag assy from the tire.
 - (2) Place the front passenger airbag assy in a plastic bag, tie it tightly and dispose of it as other general parts disposal.

CURTAIN SHIELD AIRBAG ASSY COMPONENTS

600RM-01

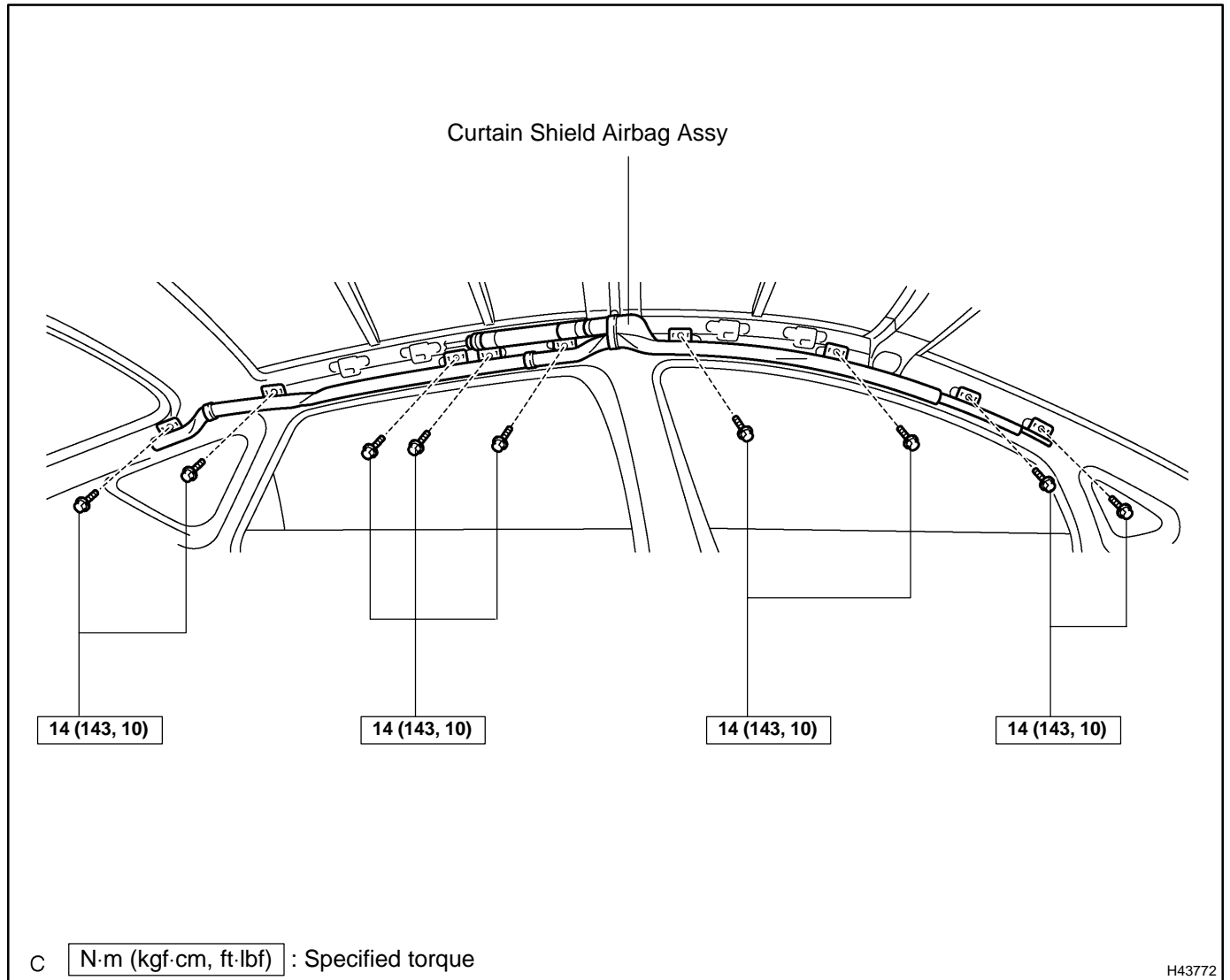

REPLACEMENT

HINT:

- Use the same procedures for the RH side and LH side.
- The procedures listed below are for the LH side.

1. **PRECAUTION (SEE PAGE 60-1)**
2. **DISCONNECT BATTERY NEGATIVE TERMINAL (SEE PAGE 60-1)**
3. **REMOVE ROOF HEADLINING ASSY (SEE PAGE 76-28)**
4. **REMOVE CURTAIN SHIELD AIRBAG ASSY**

(a) Disconnect the connector from the curtain shield airbag assy.

NOTICE:

When handling the airbag connector, take care not to damage the airbag wire harness.

- (b) Remove the 3 clips.
- (c) Remove the 9 bolts and the curtain shield airbag assy in the order shown in the illustration.

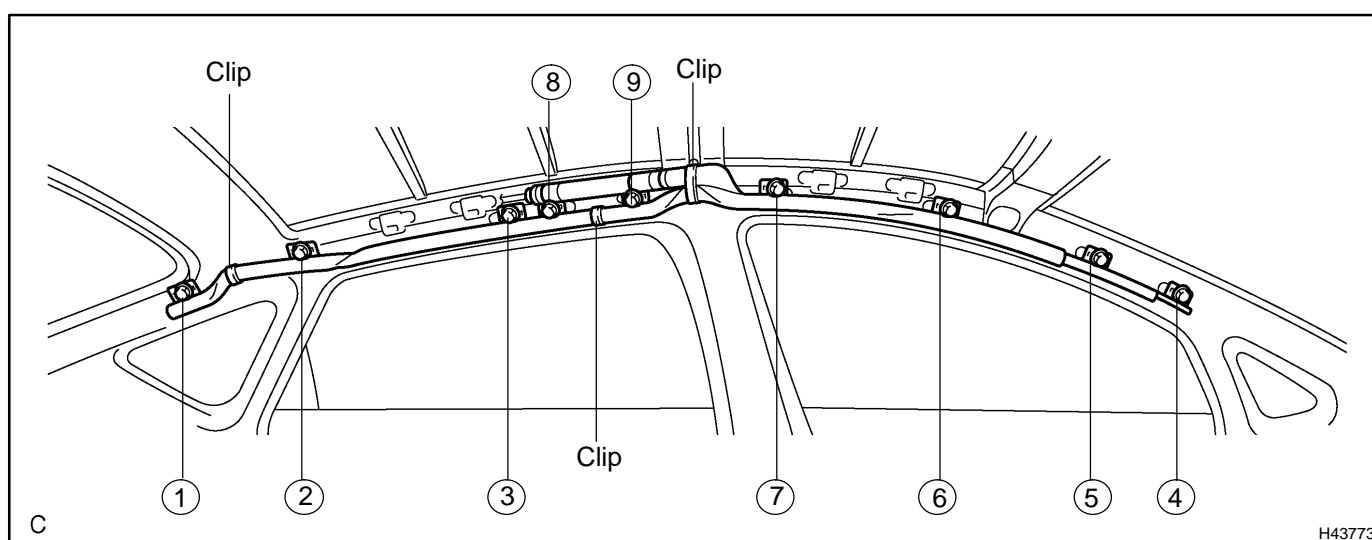

5. **INSPECT CURTAIN SHIELD AIRBAG ASSY (SEE PAGE 60-14)**

6. INSTALL CURTAIN SHIELD AIRBAG ASSY

- (a) Install the curtain shield airbag assy with the 9 bolts in the order shown in the illustration.
Torque: 14 N·m (143 kgf·cm, 10 ft·lbf)
- (b) Install the 3 clips.
- (c) Connect the connector to the curtain shield airbag assy.

NOTICE:

When handling the airbag connector, take care not to damage the airbag wire harness.

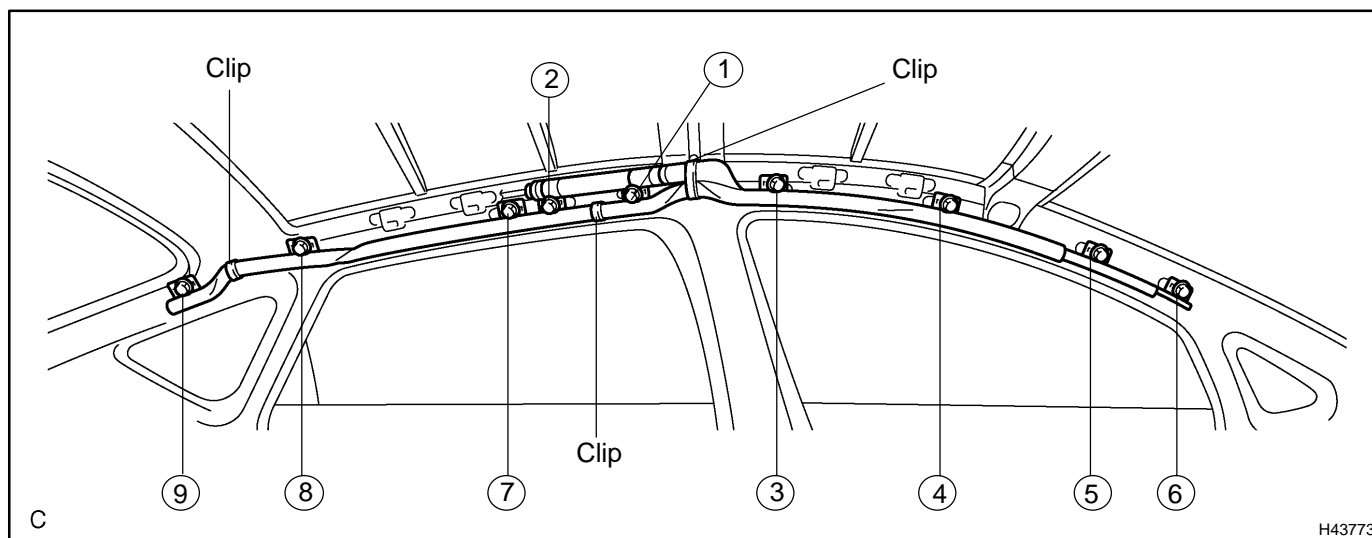
**7. INSTALL ROOF HEADLINING ASSY (SEE PAGE 76-28)****8. CONNECT BATTERY NEGATIVE TERMINAL****NOTICE:**

When disconnecting the negative (-) battery terminal, initialize the following systems after the terminal is reconnected.

| System Name | See Page |
|-----------------------------|----------|
| Power Window Control System | 01-28 |

9. INSPECT SRS WARNING LIGHT (SEE PAGE 05-1397)

DISPOSAL

HINT:

- Disposal procedure of the RH side is the same as that for the LH side.
- The procedures listed below are for the LH side.
- When scrapping a vehicle equipped with the SRS or disposing of the curtain shield airbag assy, be sure to deploy the airbag first in accordance with the procedure described below. If any abnormality occurs with the airbag deployment, contact the SERVICE DEPT. of TOYOTA MOTOR SALES, U.S.A., INC.

CAUTION:

- Never dispose of a curtain shield airbag assy that has an undeployed airbag.
- The airbag produces an exploding sound when it is deployed, so perform the operation outdoors and where it will not create a nuisance to nearby residents.

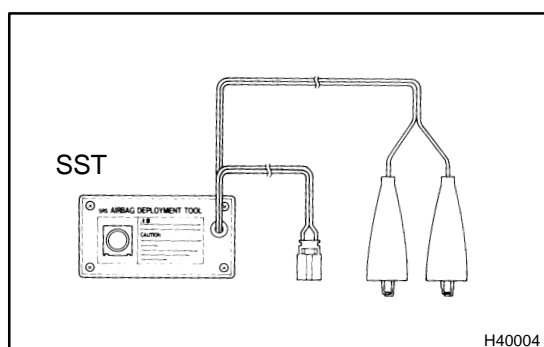

- When deploying the airbag, always use the specified SST (SRS Airbag Deployment Tool). Perform the operation in a place away from electrical noise.
- When deploying the airbag, perform the operation at least 10 m (33 ft) away from the curtain shield airbag assy.
- The curtain shield airbag assy becomes extremely hot when the airbag is deployed, so do not touch it for at least 30 minutes after deployment.
- Use gloves and safety glasses when handling a curtain shield airbag assy with a deployed airbag.
- Do not apply water, etc. to a curtain shield airbag assy with a deployed airbag.
- Always wash your hands with water after completing the operation.

1. DISPOSE OF CURTAIN SHIELD AIRBAG ASSY (WHEN INSTALLED IN VEHICLE)

HINT:

Prepare a battery as the power source to deploy the airbag.

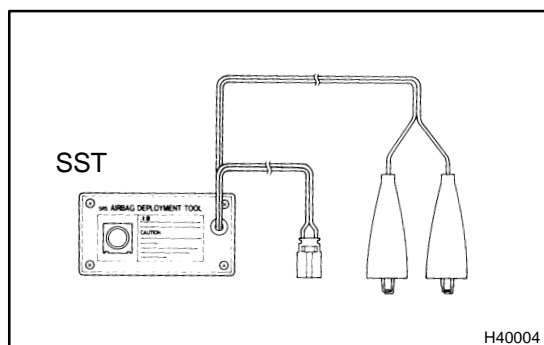

- Check the function of the SST (see step 1-(a) on page 60-22).
- Precaution (see page 60-1).
- Disconnect the battery negative terminal (see page 60-1).
- Remove the roof headlining assy (see page 76-28).

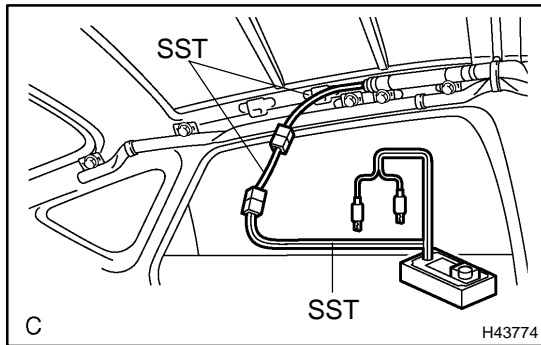

- (e) Install the SST.
- (1) Disconnect the connector from the curtain shield airbag assy.

NOTICE:

When handling the airbag connector, take care not to damage the airbag wire harness.

- (2) After connecting the SST below to each other, connect them to the curtain shield airbag assy.

SST 09082-00700, 09082-00802 (09082-10801, 09082-20801)

NOTICE:

To avoid damaging the SST connector and wire harness, do not lock the secondary lock of the twin lock.

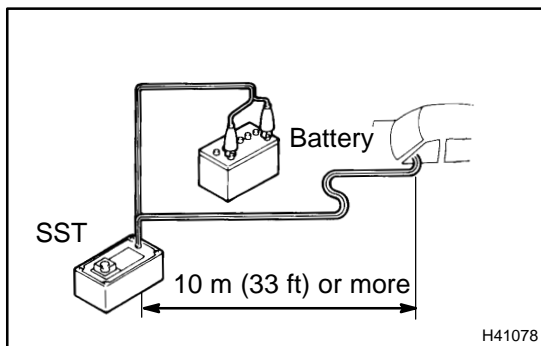

- (3) Move the SST at least 10 m (33 ft) away from the vehicle rear side window.
- (4) Maintaining enough clearance for the SST wire harness in the rear side window, close all doors and windows of the vehicle.

NOTICE:

Take care not to damage the SST wire harness.

- (5) Connect the red clip of the SST to the battery positive (+) terminal and the black clip of the SST to the negative (-) terminal.

- (f) Deploy the airbag.

- (1) Check that no one is inside the vehicle or within a 10 m (33 ft) radius of the vehicle.
- (2) Press the SST activation switch and deploy the airbag.

CAUTION:

- **When deploying the airbag, make sure that no one is near the vehicle.**
- **The curtain shield airbag assy becomes extremely hot when the airbag is deployed, so do not touch it for at least 30 minutes after deployment.**
- **Use gloves and safety glasses when handling a curtain shield airbag assy with a deployed airbag.**
- **Do not apply water, etc. to a curtain shield airbag assy with a deployed airbag.**
- **Always wash your hands with water after completing the operation.**

HINT:

The airbag is deployed as the LED of the SST activation switch comes on.

2. DISPOSE OF CURTAIN SHIELD AIRBAG ASSY (WHEN NOT INSTALLED IN VEHICLE)

NOTICE:

- When disposing of the curtain shield airbag assy, never use the customer's vehicle to deploy the airbag.
- Be sure to follow the procedure detailed below when deploying the airbag.

HINT:

Prepare a battery as the power source to deploy the airbag.

- Check the function of the SST (see step 1-(a) on page 60-22).
- Remove the curtain shield airbag assy (see page 60-41).

CAUTION:

When removing the curtain shield airbag assy, work must be started 90 seconds after the power switch is turned off and the negative (-) terminal cable is disconnected from the battery.

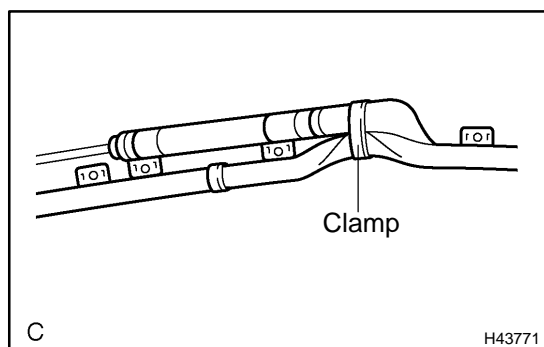
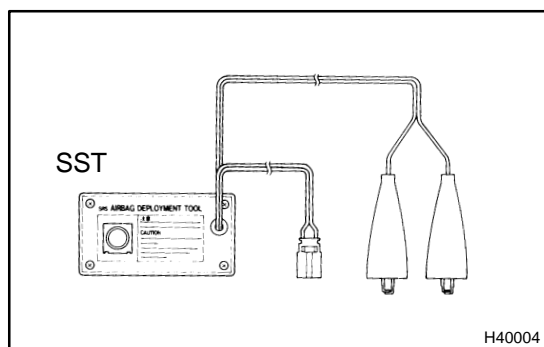

- Remove the clamp from the curtain shield airbag assy.

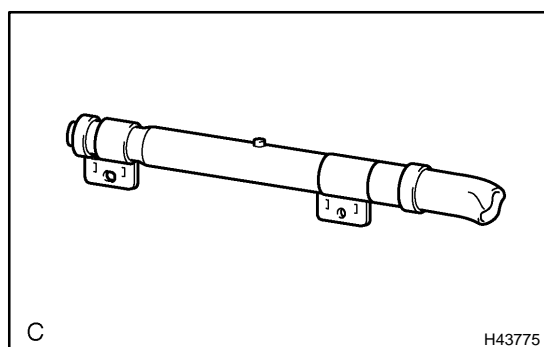

- Cut off the deployment section of the curtain shield airbag assy.

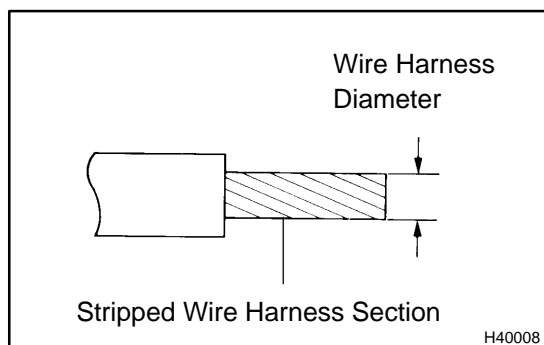

- Using a service-purpose wire harness for the vehicle, tie down the curtain shield airbag assy to the tire.
Wire harness: Stripped wire harness section 1.25 mm² or more (0.0019 in.² or more)

CAUTION:

If the wire harness is too thin or an alternative object is used to tie down the curtain shield airbag assy, it may be snapped by the shock when the airbag is deployed. Always use a wire harness for vehicle use with an area of at least 1.25 mm² (0.0019 in²).

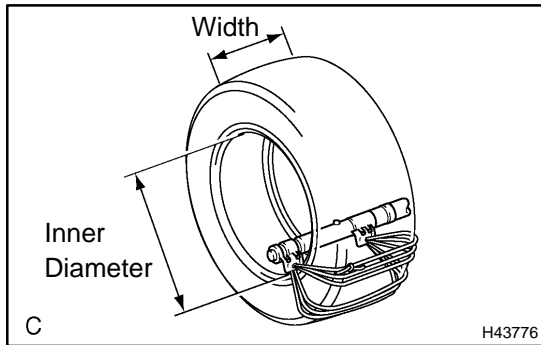
**HINT:**

- To calculate the area of the stripped wire harness section:
Area = 3.14 x (Diameter)² divided by 4
 - Position the curtain shield airbag assy inside the tire as shown in the illustration.

Tire size: Must exceed the following dimensions
Width: 185 mm (7.28 in.)
Inner diameter: 360 mm (14.17 in.)

CAUTION:

- Make sure that the wire harness is tight. If there is slack in wire harness, the curtain shield airbag assy may become loose due to the shock when the airbag is deployed.

NOTICE:

The tire will be marked by the airbag deployment, so use an extra tire.

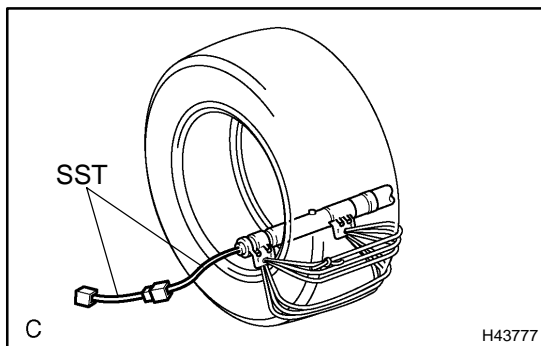

- Install the SST.
 After connecting the SST below to each other, connect them to the curtain shield airbag assy.
 SST 09082-00700, 09082-00802 (09082-10801, 09082-20801)

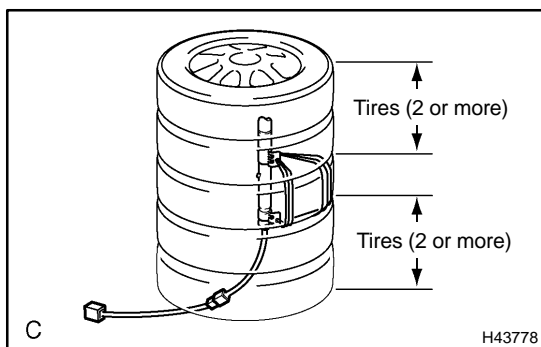

- Place the tires.
- CAUTION:**
Do not place the deployment direction of the curtain shield airbag assy facing toward the ground.
- Place at least 2 tires under the tire which the curtain shield airbag assy is tied to.
 - Place at least 2 tires over the tire which the curtain shield airbag assy is tied to. The top tire should have the disc wheel installed.

NOTICE:

Do not place the SST connector under the tire because it could be damaged.

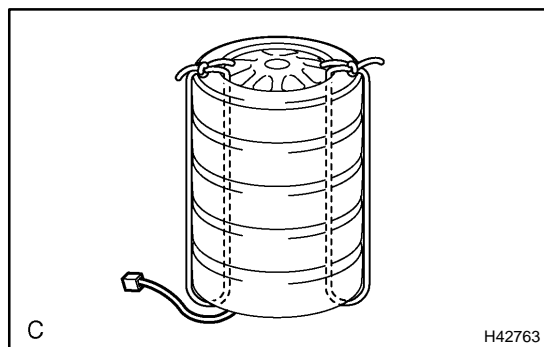

- (3) Tie the tires together with 2 wire harnesses.

CAUTION:

Make sure that the wire harness is tight. It is highly dangerous when looseness in the wire harness results in the tires coming free due to the shock when the airbag is deployed.

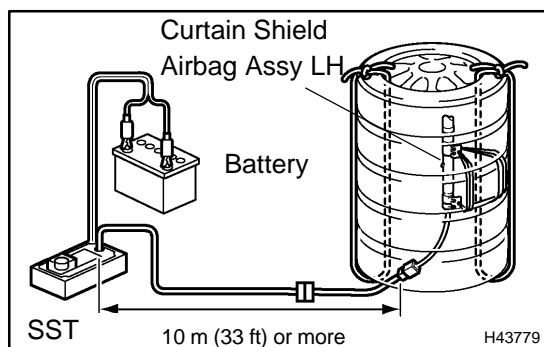

- (h) Install the SST.
Connect the SST connector.

NOTICE:

To avoid damaging the SST connector and wire harness, do not lock the secondary lock of the twin lock. Also, secure some slack for the SST wire harness inside the tire.

- (i) Deploy the airbag.
- (1) Connect the red clip of the SST to the battery positive (+) terminal and the black clip of the SST to the battery negative (-) terminal.
 - (2) Check that no one is within a 10 m (33 ft) radius of the tire which the curtain shield airbag assy is tied to.
 - (3) Press the SST activation switch and deploy the airbag.

CAUTION:

When deploying the airbag, make sure that no one is near the tire.

HINT:

The airbag is deployed as the LED of the SST activation switch comes on.

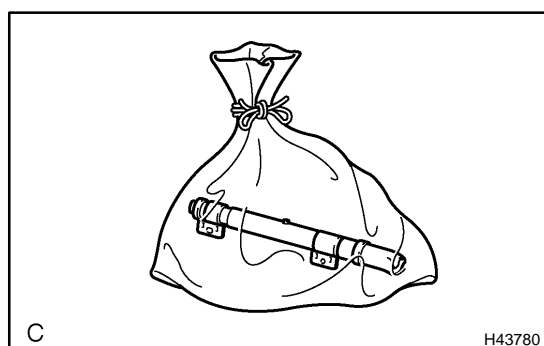

- (j) Dispose of the curtain shield airbag assy.

CAUTION:

- The curtain shield airbag assy becomes extremely hot when the airbag is deployed, so do not touch it for at least 30 minutes after deployment.
 - Use gloves and safety glasses when handling a curtain shield airbag assy with a deployed airbag.
 - Always wash your hands with water after completing the operation.
 - Do not apply water, etc. to a curtain shield airbag assy with a deployed airbag.
- (1) Remove the curtain shield airbag assy from the tire.
 - (2) Place the curtain shield airbag assy in a plastic bag, tie it tightly and dispose of it as other general parts disposal.

FRONT SEAT AIRBAG ASSY

600RP-01

DISPOSAL

HINT:

- Disposal procedure of the RH side is the same as that for the LH side.
- The procedures listed below are for the LH side.
- When scrapping a vehicle equipped with the SRS or disposing of the front seat airbag assy, be sure to deploy the airbag first in accordance with the procedure described below. If any abnormality occurs with the airbag deployment, contact the SERVICE DEPT. of TOYOTA MOTOR SALES, U.S.A., INC.

CAUTION:

- **Never dispose of a front seat airbag assy that has an undeployed airbag.**
- **The airbag produces an exploding sound when it is deployed, so perform the operation outdoors and where it will not create a nuisance to nearby residents.**

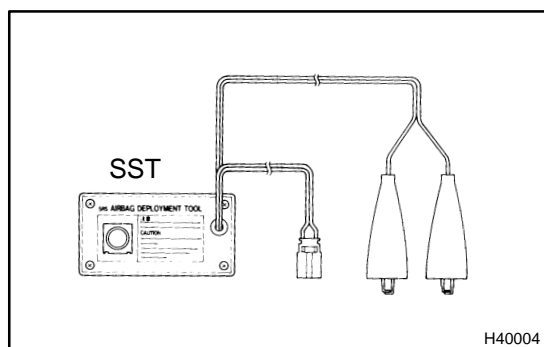

- **When deploying the airbag, always use the specified SST (SRS Airbag Deployment Tool). Perform the operation in a place away from electrical noise.**
- **When deploying the airbag, perform the operation at least 10 m (33 ft) away from the airbag assy.**
- **The front seat airbag assy becomes extremely hot when the airbag is deployed, so do not touch it for at least 30 minutes after deployment.**
- **Use gloves and safety glasses when handling a front seat airbag assy with a deployed airbag.**
- **Always wash your hands with water after completing the operation.**
- **Do not apply water, etc. to a front seat airbag assy with a deployed airbag.**

1. DISPOSE OF FRONT SEAT AIRBAG ASSY (WHEN INSTALLED IN VEHICLE)

HINT:

Prepare a battery as the power source to deploy the airbag.

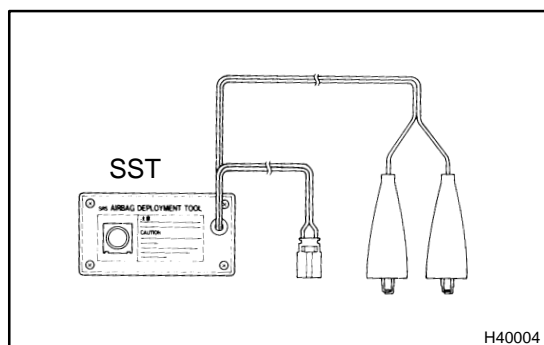

- Check the function of the SST (see step 1– (a) on page 60-22).
- Precaution (see page 60-1).
- Disconnect the battery negative terminal (see page 60-1).
- Remove the 4 bolts from the front seat assy (see page 72-2).

HINT:

Keep the front seat assy in the cabin.

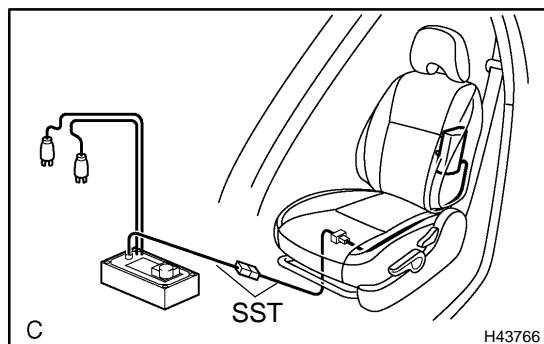

- (e) Install the SST.
- (1) Disconnect the connector (yellow colored one) from the front seat airbag assy.

NOTICE:

When handling the airbag connector, take care not to damage the airbag wire harness.

- (2) Connect the SST connector to the front seat airbag assy.

SST 09082-00700, 09082-00750

NOTICE:

To avoid damaging the SST connector and wire harness, do not lock the secondary lock of the twin lock.

- (3) Install the 4 bolts to the front seat assy.

Torque: 37 N·m (375 kgf·cm, 27 ft·lbf)

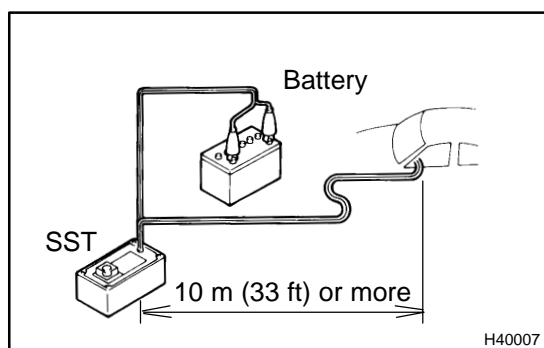

- (4) Move the SST at least 10 m (33 ft) away from the vehicle front side window.
- (5) Maintaining enough clearance for the SST wire harness in the front side window, close all doors and windows of the vehicle.

NOTICE:

Take care not to damage the SST wire harness.

- (6) Connect the red clip of the SST to the battery positive (+) terminal and the black clip of the SST to the battery negative (-) terminal.

- (f) Deploy the airbag.

- (1) Check that no one is inside the vehicle or within a 10 m (33 ft) radius of the vehicle.
- (2) Press the SST activation switch and deploy the airbag.

CAUTION:

- **When deploying the airbag, make sure that no one is near the vehicle.**
- **The front seat airbag assy becomes extremely hot when the airbag is deployed, so do not touch it for at least 30 minutes after deployment.**
- **Use gloves and safety glasses when handling a front seat airbag assy with a deployed airbag.**
- **Do not apply water, etc. to a front seat airbag assy with a deployed airbag.**
- **Always wash your hands with water after completing the operation.**

HINT:

The airbag is deployed as the LED of the SST activation switch comes on.

2. DISPOSE OF FRONT SEAT AIRBAG ASSY (WHEN NOT INSTALLED IN VEHICLE)

NOTICE:

- When disposing of the front seat airbag assy, never use the customer's vehicle to deploy the airbag.
- Be sure to follow the procedure detailed below when deploying the airbag.

HINT:

Prepare a battery as the power source to deploy the airbag.

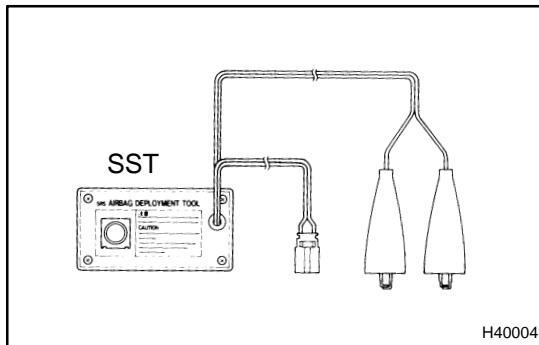

- Check the function of the SST (see step 1– (a) on page 60-22).
- Remove the front seat airbag assy.
 - Remove the front seat assy (see page 72-2).
 - Remove the 2 nuts and the front seat airbag assy from the seatback assy.

CAUTION:

- When removing the front seat airbag assy, work must be started 90 seconds after the power switch is turned off and the negative (–) terminal cable is disconnected from the battery.
- When storing the front seat airbag assy, keep the upper surface of the airbag deployment side facing upward.

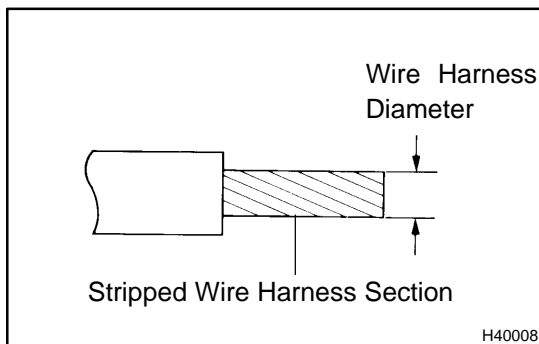

- Using a service-purpose wire harness for the vehicle, tie down the front seat airbag assy.

**Wire harness: Stripped wire harness section
1.25 mm² or more (0.0019 in² or more)**

HINT:

- To calculate the area of the stripped wire harness section:
Area = 3.14 x (Diameter)² divided by 4

CAUTION:

If the wire harness is too thin or an alternative object is used to tie down the front seat airbag assy, it may be snapped by the shock when the airbag is deployed. Always use a wire harness for vehicle use with an area of at least 1.25 mm² (0.0019 in²).

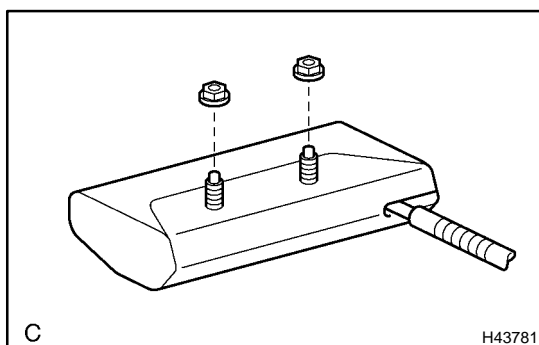

- Install the 2 nuts in the front seat airbag assy.

SUPPLEMENTAL RESTRAINT SYSTEM – FRONT SEAT AIRBAG ASSY

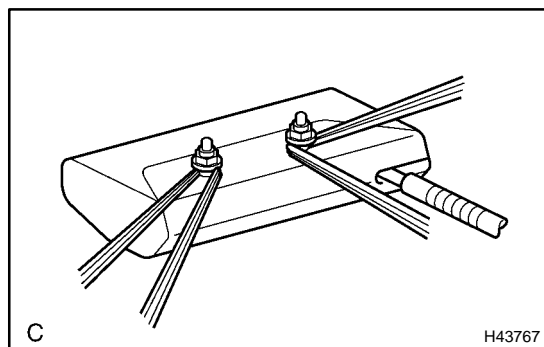

- (2) Wind the wire harness around the stud bolts of the front seat airbag assy as shown in the illustration.

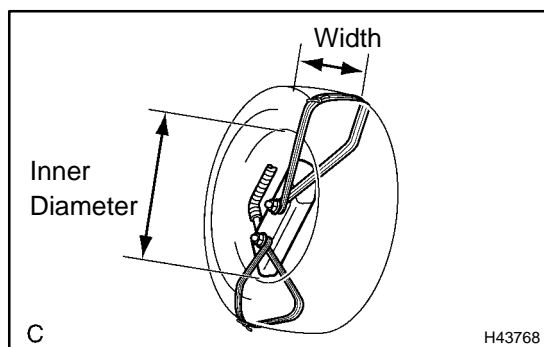

- (3) Position the front seat airbag assy inside the tire as shown in the illustration.

Tire size: Must exceed the following dimensions

Width: 185 mm (7.28 in.)

Inner diameter: 360 mm (14.17 in.)

CAUTION:

- **Make sure that the wire harness is tight. If there is slack in wire harness, the front seat airbag assy may become loose due to the shock when the airbag is deployed.**
- **Always tie down the front seat airbag assy with the airbag deployment direction facing inside the tire.**

NOTICE:

The tire will be marked by the airbag deployment, so use an extra tire.

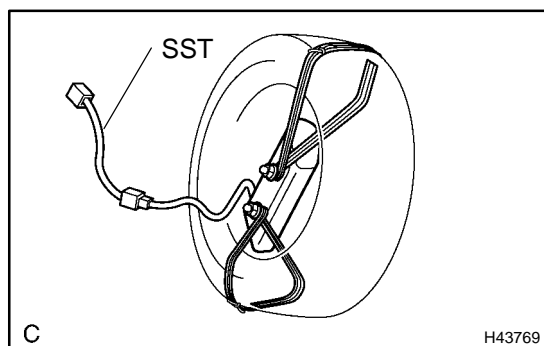

- (d) Install the SST.
Connect the SST connector to the front seat airbag assy connector.
SST 09082-00750

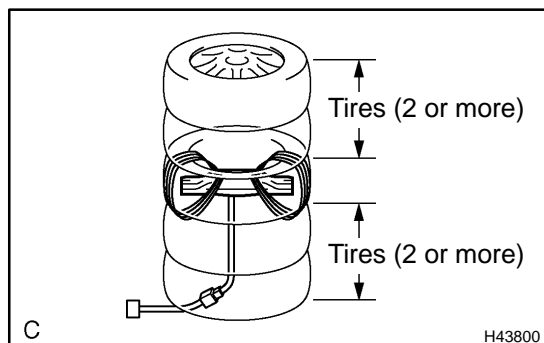

- (e) Place the tires.
- (1) Place at least 2 tires under the tire which the front seat airbag assy is tied to.
 - (2) Place at least 2 tires over the tire which the front seat airbag assy is tied to. The top tire should have the disc wheel installed.

NOTICE:

Do not place the SST connector under the tire because it could be damaged.

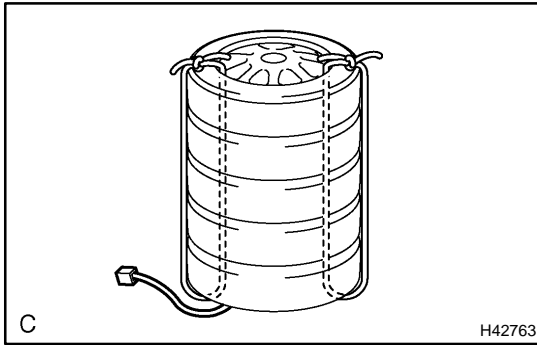

- (3) Tie the tires together with 2 wire harnesses.

CAUTION:

Make sure that the wire harness is tight. It is highly dangerous when looseness in the wire harness results in the tires coming free due to the shock when the airbag is deployed.

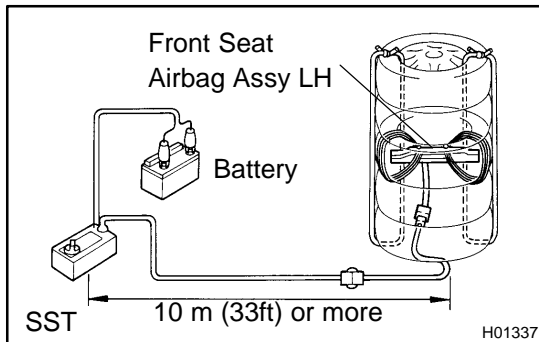

- (f) Install the SST.
Connect the SST connector.
SST 09082-00700

NOTICE:

To avoid damaging the SST connector and wire harness, do not lock the secondary lock of the twin lock. Also, secure some slack for the SST wire harness inside the tire.

- (g) Deploy the airbag.
- (1) Connect the red clip of the SST to the battery positive (+) terminal and the black clip of the SST to the battery negative (-) terminal.
 - (2) Check that no one is within a 10 m (33 ft) radius of the tire which the front seat airbag assy is tied to.
 - (3) Press the SST activation switch and deploy the airbag.

CAUTION:

When deploying the airbag, make sure that no one is near the tire.

HINT:

The airbag is deployed as the LED of the SST activation switch comes on.



- (h) Dispose of the front seat airbag assy.

CAUTION:

- The front seat airbag assy becomes extremely hot when the airbag is deployed, so do not touch it for at least 30 minutes after deployment.
 - Use gloves and safety glasses when handling a front seat airbag assy with a deployed airbag.
 - Always wash your hands with water after completing the operation.
 - Do not apply water, etc. to a front seat airbag assy with a deployed airbag.
- (1) Remove the front seat airbag assy from the tire.
 - (2) Place the front seat airbag assy in a plastic bag, tie it tightly and dispose of it as other general parts disposal.

AIR BAG ECU ASSY COMPONENTS

600KO-04

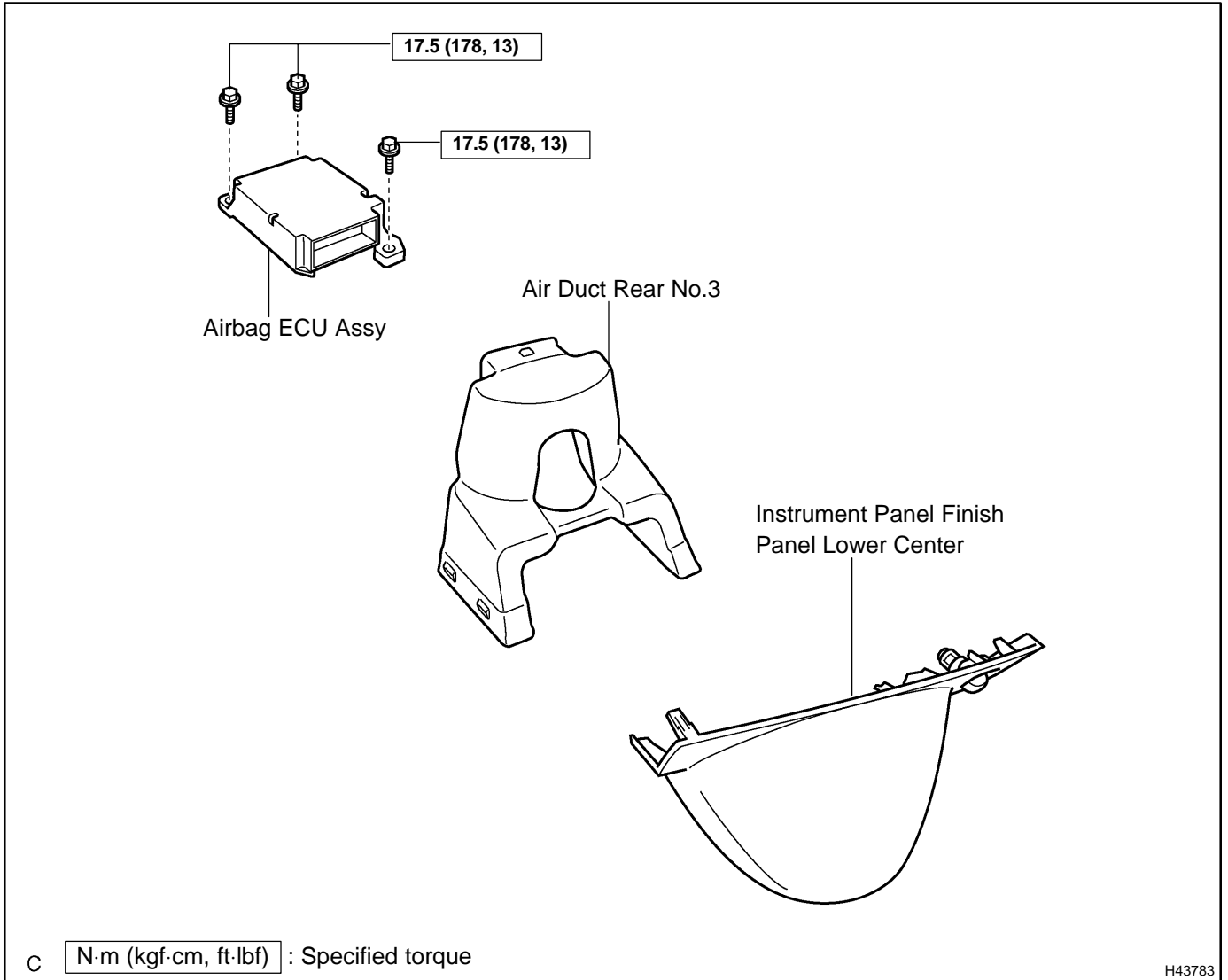

REPLACEMENT

HINT:

Installation is in the reverse order of removal.

1. **PRECAUTION (SEE PAGE 60-1)**
2. **DISCONNECT BATTERY NEGATIVE TERMINAL (SEE PAGE 60-1)**
3. **REMOVE INSTRUMENT PANEL FINISH PANEL LOWER CENTER (SEE PAGE 71-13)**
4. **REMOVE AIR DUCT REAR NO.3 (SEE PAGE 55-17)**

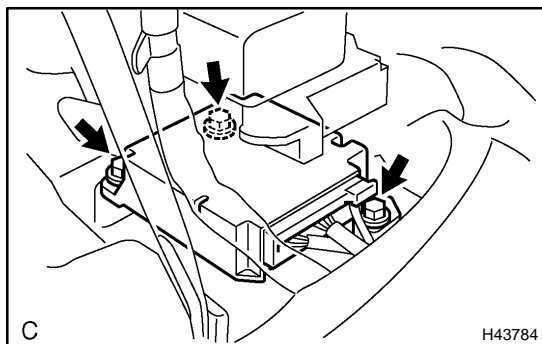

5. REMOVE AIR BAG ECU ASSY

- (a) Disconnect the holder (with connectors) from the airbag ECU assy.
- (b) Remove the 3 bolts and the airbag ECU assy.

6. INSTALL AIR BAG ECU ASSY

- (a) Check that the power switch is off.
- (b) Check that the battery negative (–) terminal is disconnected.

NOTICE:

After removing the terminal, wait for at least 90 seconds before starting the operation.

- (c) Install the airbag ECU assy with the 3 bolts.

Torque: 17.5 N·m (178 kgf·cm, 13 ft·lbf)

NOTICE:

- If the airbag ECU assy has been dropped, or there are any cracks, dents or other defects in the case, bracket or connector, replace it with a new one.
 - When installing the airbag ECU assy, be careful that the SRS wiring does not interfere with other parts and that it is not pinched between other parts.
- (d) Check that there is no looseness in the installation parts of the airbag ECU assy.
 - (e) Connect the holder (with connectors) to the airbag ECU assy.
 - (f) Check that the water-proof sheet is properly set.

7. CONNECT BATTERY NEGATIVE TERMINAL

NOTICE:

When disconnecting the negative (–) battery terminal, initialize the following systems after the terminal is reconnected.

| System Name | See Page |
|-----------------------------|----------|
| Power Window Control System | 01-28 |

8. INSPECT SRS WARNING LIGHT (SEE PAGE 05-1397)

AIRBAG SENSOR FRONT COMPONENTS

600KQ-05

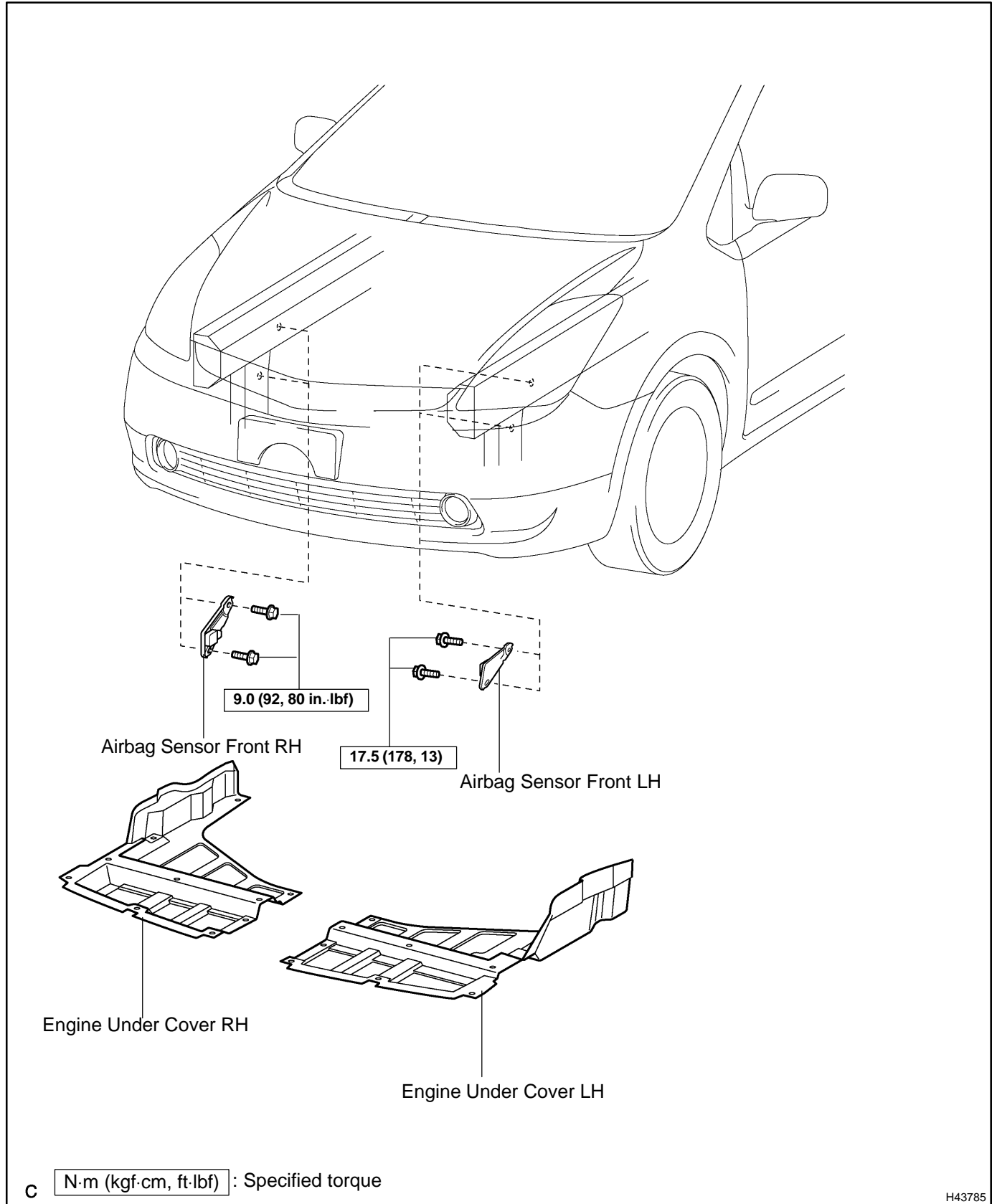

REPLACEMENT

HINT:

- Use the same procedures for the RH side and LH side.
 - The procedures listed below are for the LH side.
 - Installation is in the reverse order of removal.
1. **PRECAUTION (SEE PAGE 60-1)**
 2. **DISCONNECT BATTERY NEGATIVE TERMINAL (SEE PAGE 60-1)**
 3. **REMOVE ENGINE UNDER COVER (SEE PAGE 14-32)**

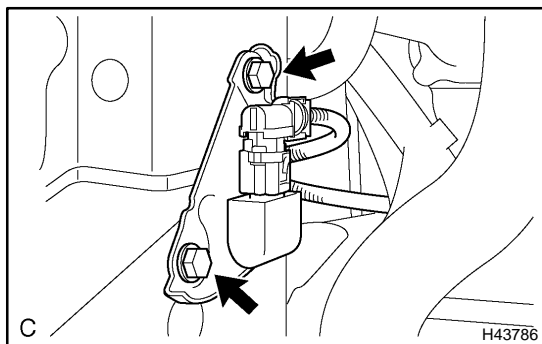

4. REMOVE AIRBAG SENSOR FRONT

- (a) Disconnect the connector from the airbag sensor front.
- (b) Remove the 2 bolts and the airbag sensor front.

5. INSTALL AIRBAG SENSOR FRONT

- (a) Check that the power switch is off.
- (b) Check that the battery negative (–) terminal is disconnected.

CAUTION:

After removing the terminal, wait for at least 90 seconds before starting the operation.

- (c) Install the airbag sensor front with the 2 bolts.

Torque:

LH Side: 17.5 N·m (178 kgf·cm, 13 ft·lbf)

RH Side: 9.0 N·m (92 kgf·cm, 80 in·lbf)

NOTICE:

- If the airbag sensor front has been dropped, or there are any cracks, dents or other defects in the case, bracket or connector, replace it with a new one.
 - When installing the airbag sensor front, be careful that the SRS wiring does not interfere with other parts and that it is not pinched between other parts.
- (d) Check that there is no looseness in the installation parts of the airbag sensor front.
 - (e) Connect the connector to the airbag sensor front.

6. CONNECT BATTERY NEGATIVE TERMINAL

NOTICE:

When disconnecting the negative (–) battery terminal, initialize the following systems after the terminal is reconnected.

| System Name | See Page |
|-----------------------------|----------|
| Power Window Control System | 01-28 |

7. INSPECT SRS WARNING LIGHT (SEE PAGE 05-1397)

SIDE AIRBAG SENSOR ASSY COMPONENTS

600RR-01

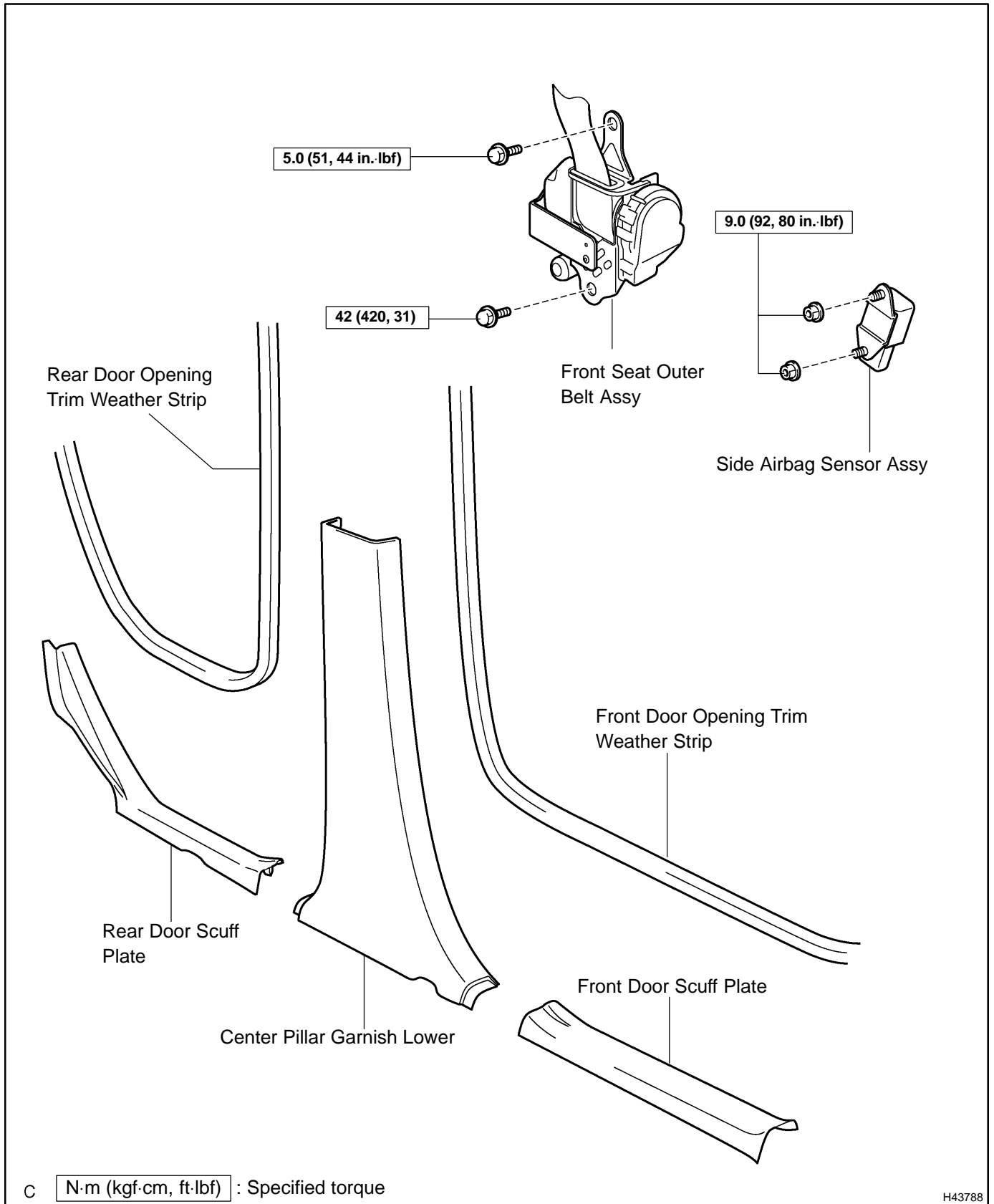

REPLACEMENT

HINT:

- Use the same procedures for the RH side and LH side.
 - The procedures listed below are for the LH side.
 - Installation is in the reverse order of removal.
1. **PRECAUTION (SEE PAGE 60-1)**
 2. **DISCONNECT BATTERY NEGATIVE TERMINAL (SEE PAGE 60-1)**
 3. **REMOVE FRONT DOOR SCUFF PLATE (SEE PAGE 61-9)**
 4. **REMOVE REAR DOOR SCUFF PLATE (SEE PAGE 61-9)**
 5. **REMOVE FRONT DOOR OPENING TRIM WEATHERSTRIP (SEE PAGE 61-9)**
 6. **REMOVE REAR DOOR OPENING TRIM WEATHERSTRIP (SEE PAGE 61-9)**
 7. **REMOVE CENTER PILLAR GARNISH LOWER (SEE PAGE 61-9)**
 8. **REMOVE FRONT SEAT OUTER BELT ASSY (SEE PAGE 61-9)**

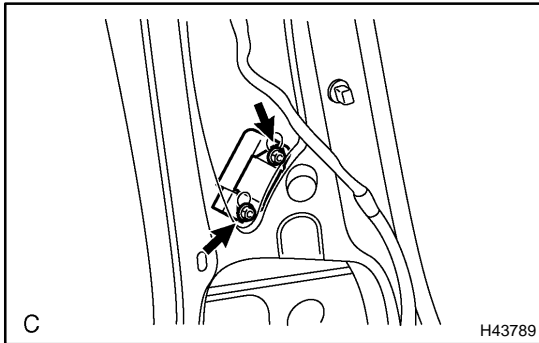

9. REMOVE SIDE AIRBAG SENSOR ASSY

- (a) Disconnect the connector from the side airbag sensor assy.
- (b) Remove the 2 nuts and the side airbag sensor assy.

10. INSTALL SIDE AIRBAG SENSOR ASSY

- (a) Check that the power switch is off.
- (b) Check that the battery negative (–) terminal is disconnected.

CAUTION:

After removing the terminal, wait for at least 90 seconds before starting the operation.

- (c) Install the side airbag sensor assy with the 2 nuts.

Torque: 9.0 N·m (92 kgf·cm, 80 in.·lbf)

NOTICE:

- If the side airbag sensor assy has been dropped, or there are any cracks, dents or other defects in the case, bracket or connector, replace it with a new one.
 - When installing the side airbag sensor assy, be careful that the SRS wiring does not interfere with other parts and that it is not pinched between other parts.
- (d) Check that there is no looseness in the installation parts of the side airbag sensor assy.
 - (e) Connect the connector to the side airbag sensor assy.

11. INSTALL FRONT SEAT OUTER BELT ASSY (SEE PAGE 61-9)

12. CONNECT BATTERY NEGATIVE TERMINAL

NOTICE:

When disconnecting the negative (–) battery terminal, initialize the following systems after the terminal is reconnected.

| System Name | See Page |
|-----------------------------|----------|
| Power Window Control System | 01-28 |

13. INSPECT SRS WARNING LIGHT (SEE PAGE 05-1397)

AIRBAG SENSOR REAR COMPONENTS

600KU-05

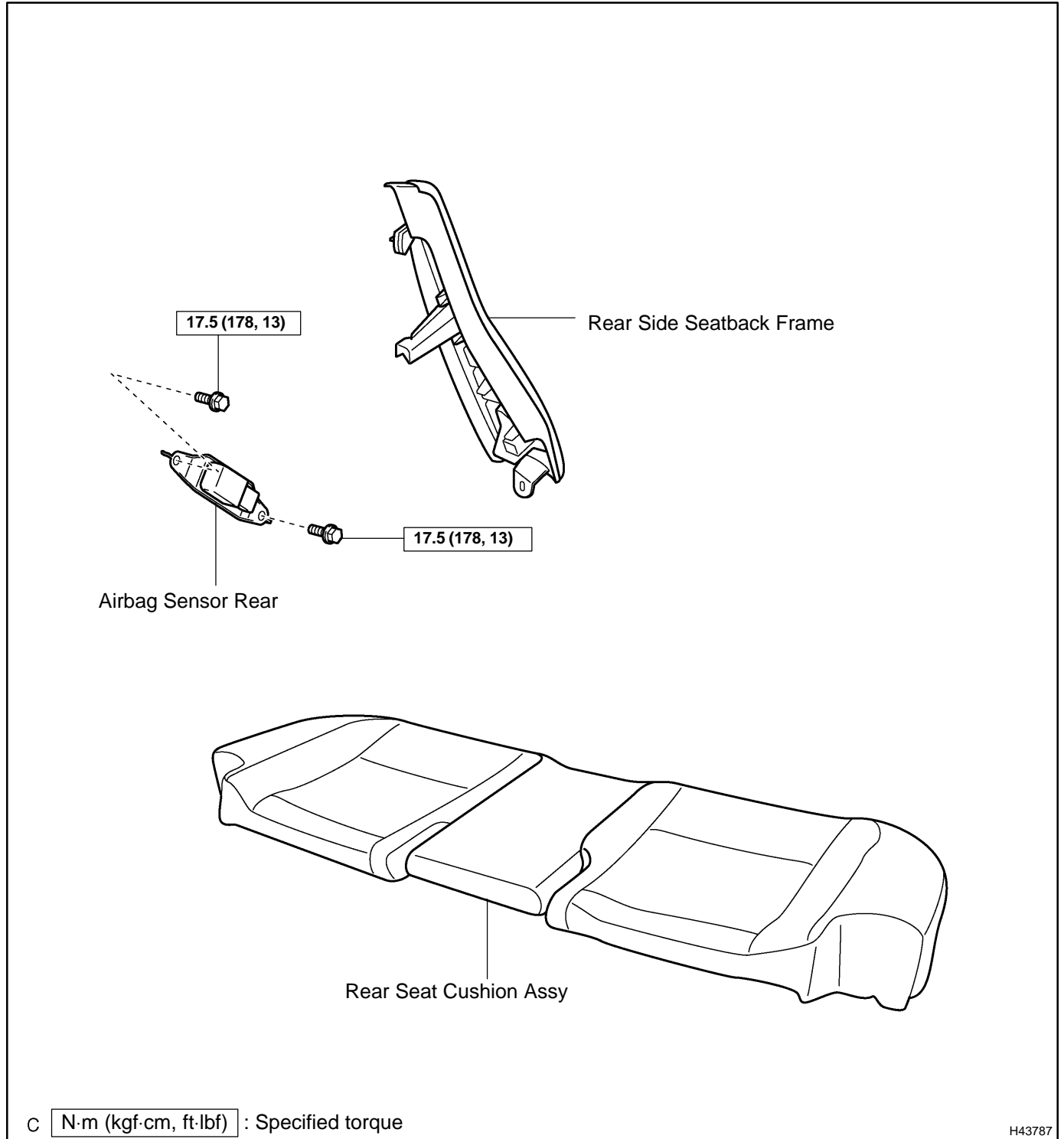

REPLACEMENT

HINT:

- Use the same procedures for the RH side and LH side.
 - The procedures listed below are for the LH side.
 - Installation is in the reverse order of removal.
1. **PRECAUTION (SEE PAGE 60-1)**
 2. **DISCONNECT BATTERY NEGATIVE TERMINAL (SEE PAGE 60-1)**
 3. **REMOVE REAR SEAT CUSHION ASSY (SEE PAGE 72-9)**
 4. **REMOVE REAR SIDE SEAT BACK FRAME (SEE PAGE 61-17)**

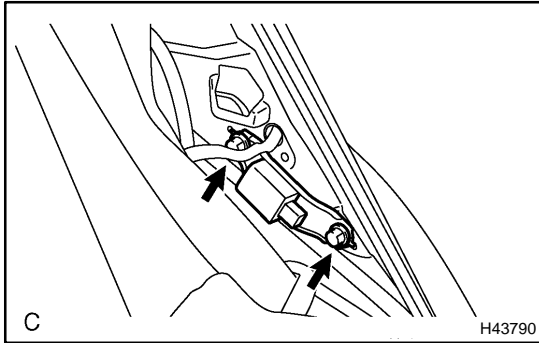

5. REMOVE AIRBAG SENSOR REAR

- (a) Disconnect the connector from the airbag sensor rear.
- (b) Remove the 2 bolts and the airbag sensor rear.

6. INSTALL AIRBAG SENSOR REAR

- (a) Check that the power switch is off.
- (b) Check that the battery negative (-) terminal is disconnected.

CAUTION:

After removing the terminal, wait for at least 90 seconds before starting the operation.

- (c) Install the airbag sensor rear with the 2 bolts.

Torque: 17.5 N·m (178 kgf·cm, 13 ft·lbf)

NOTICE:

- If the airbag sensor rear has been dropped, or there are any cracks, dents or other defects in the case, bracket or connector, replace it with a new one.
 - When installing the airbag sensor rear, be careful that the SRS wiring does not interfere with other parts and that it is not pinched between other parts.
- (d) Check that there is no looseness in the installation parts of the airbag sensor rear.
 - (e) Connect the connector to the airbag sensor rear.

7. CONNECT BATTERY NEGATIVE TERMINAL

NOTICE:

When disconnecting the negative (-) battery terminal, initialize the following systems after the terminal is reconnected.

| System Name | See Page |
|-----------------------------|----------|
| Power Window Control System | 01-28 |

8. INSPECT SRS WARNING LIGHT (SEE PAGE 05-1397)

SEAT POSITION AIR BAG SENSOR COMPONENTS

600KV-04

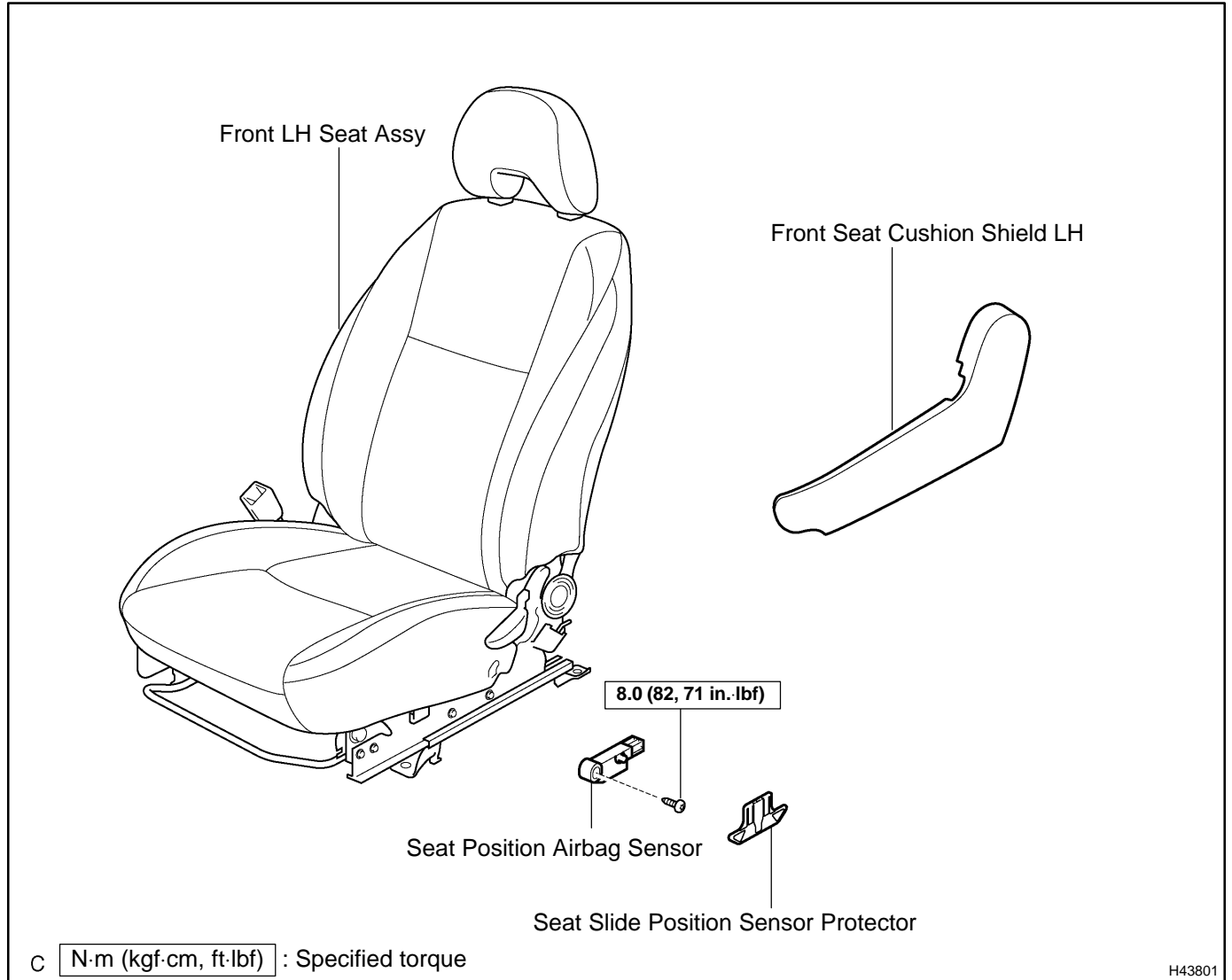

REPLACEMENT

1. PRECAUTION (SEE PAGE 60-1)
2. DISCONNECT BATTERY NEGATIVE TERMINAL (SEE PAGE 60-1)
3. REMOVE FRONT LH SEAT ASSY (SEE PAGE 72-2)
4. REMOVE FRONT SEAT CUSHION SHIELD LH (SEE PAGE 72-2)

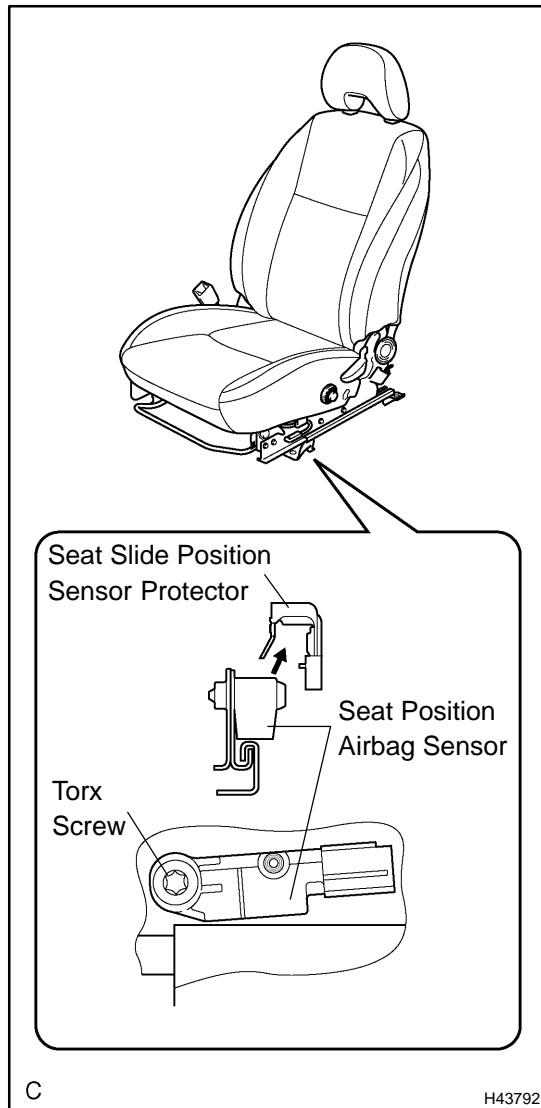

5. REMOVE SEAT SLIDE POSITION SENSOR PROTECTOR

- (a) Remove the seat slide position sensor protector from the seat position airbag sensor.

6. REMOVE SEAT POSITION AIR BAG SENSOR

- (a) Disconnect the connector from the seat position airbag sensor.
- (b) Using a torx socket wrench (T30), remove the torx screw and the seat position airbag sensor.

7. INSTALL SEAT POSITION AIR BAG SENSOR

- (a) Check that the power switch is off.
- (b) Check that the battery negative (-) terminal is disconnected.

CAUTION:

After removing the terminal, wait for at least 90 seconds before starting the operation.

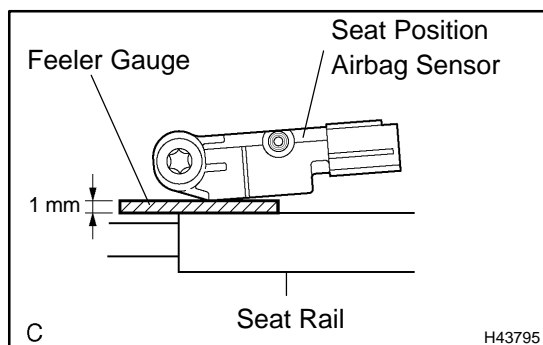

- (c) Using a feeler gauge 1 mm (0.039 in.), install the seat position airbag sensor.

NOTICE:

- If the seat position airbag sensor has been dropped, or there are any cracks, dents or other defects in the case, bracket or connector, replace the seat position airbag sensor with a new one.
- When installing the seat position airbag sensor, be careful that the SRS wiring does not interfere with other parts and that it is not pinched between other parts.

HINT:

Be sure to maintain a clearance between the seat position airbag sensor and the seat rail is within 0.6 mm (0.023 in.) to 2 mm (0.079 in.).

- (d) Using a torx socket wrench (T30), tighten the torx screw to install the seat position airbag sensor.
Torque: 8.0 N·m (82 kgf·cm, 71 in.-lbf)
- (e) Make sure that a clearance between the seat position airbag sensor and the seat rail is within 0.6 mm (0.023 in.) to 2 mm (0.079 in.).
- (f) Check that there is no looseness in the installation parts of the seat position airbag sensor.
- (g) Connect the connector to the seat position airbag sensor.

8. INSTALL FRONT LH SEAT ASSY (SEE PAGE 72-2)**9. CONNECT BATTERY NEGATIVE TERMINAL****NOTICE:**

When disconnecting the negative (-) battery terminal, initialize the following systems after the terminal is reconnected.

| System Name | See Page |
|-----------------------------|----------|
| Power Window Control System | 01-28 |

10. INSPECT SRS WARNING LIGHT (SEE PAGE 05-1397)