

ELECTRONICALLY CONTROLLED BRAKE SYSTEM

PRECAUTION

1. TROUBLESHOOTING PRECAUTION

- (a) When there is a malfunction with terminal contact points or part installation problems, removal and installation of the suspected problem parts may return the system to the normal condition either completely or temporarily.
- (b) In order to determine the malfunctioning area, be sure to check the conditions at the time the malfunction occurred, such as DTC output and the freeze frame data, and record it before disconnecting each connector or removing and installing parts.
- (c) Since the system may be influenced by malfunctions in systems other than the brake control system, be sure to check for DTCs in other systems.

2. HANDLING PRECAUTION

- (a) Do not remove or install the Enhanced VSC or Electronically Controlled Brake (ECB) parts such as the steering sensor, yaw rate sensor or brake pedal stroke sensor except when required, as they need to be adjusted correctly after removal or installation.
- (b) Be sure to perform preparation before work and confirmation after work is completed by following the directions in the repair manual when working on the Enhanced VSC or ECB system.
- (c) Be sure to remove and install the ECU, actuator, each sensor, etc. with the power switch OFF unless otherwise specified in the inspection procedure.
- (d) Be sure to remove the 2 main relays before removal and installation, or replacement of the Enhanced VSC or ECB parts.
- (e) The removal or installation of the actuator, master cylinder or stroke simulator as well as some other procedures can cause the fluid level to drop below the fluid reservoir port. If this happens when performing such work, be sure to remove the 2 motor relays until the bleeding of the air in the pipeline is completed.

HINT:

- When the pump motor is operated with the air in the brake actuator hose, bleeding the air becomes difficult due to air in the actuator.
- The skid control ECU may operate the stroke simulator and drive the pump motor even when the power switch is OFF.

- The ECB system has its own auxiliary power source. This system can be operated after disconnecting the negative terminal from the auxiliary battery (12 V) until the discharge is completed.
 - With the power switch OFF, the skid control ECU can be operated for 2 minutes after the brake operation is finished.
- (f) Removal of the main relay and motor relay
- (1) Wait for 2 minutes after turning the power switch OFF, stopping the brake pedal operation and closing the driver door before removing the 2 relays.
- HINT:
The above situation occurs when the pump motor operates to prepare for the next operation just before brake control system turns off.
- (g) When removing and installing the ECU, actuator and each sensor, be sure to check that the normal display is output in test mode inspection and in DTC output inspection after installing all the parts.

3. DTC PRECAUTION

- (a) Warnings for some DTCs cannot be cleared only by repairing the malfunctioning parts. If the warning is displayed after repair work, the DTC should be cleared after turning the power switch OFF.

NOTICE:

If a DTC is cleared but the malfunction still continues, the DTC is stored again.

4. FAIL-SAFE PRECAUTION

- (a) When trouble occurs in the brake control systems, the skid control ECU lights up the warning lights (ECB, ABS, Enhanced VSC and BRAKE) corresponding to the malfunctioning systems and prohibits ABS, Enhanced VSC and brake assist operation.
- (b) The control of the ECB can be continued by only the normal parts according to the malfunction.
- HINT:
- If control of the ECB for any of the 4 wheels is prohibited, that wheel loses brake booster function or braking ability.
 - If one of the 4 wheels loses brake booster function, the feel when depressing brake pedal changes as the stroke simulator (pedal reactive force generating solenoid) operation is prohibited.
 - If control of the ECB for all wheels is prohibited, the 2 front wheels lose brake booster function.

5. DRUM TESTER PRECAUTION

- (a) When using the drum tester, be sure to follow the procedures below to prohibit the Enhanced VSC operation.

NOTICE:

- **Make sure that the Enhanced VSC warning light is blinking (change to TEST MODE).**
- **Secure the vehicle with the lock chain for safety.**

6. CAN COMMUNICATION SYSTEM PRECAUTION

- (a) The CAN communication system is used for the data communication between the skid control ECU, the steering sensor, the yaw rate sensor (deceleration sensor included) and other ECUs. If there is trouble with the CAN communication line, corresponding DTCs in the communication line are output.
- (b) If a CAN communication line DTC is output, repair the malfunction in the communication line and troubleshoot the Enhanced VSC system while data communication is normal.
- (c) Since the CAN communication line has its own length and route, it cannot be repaired temporarily with a bypass wire, etc.

7. NOTICES FOR INITIALIZATION**NOTICE:**

When disconnecting the cable from the negative (-) battery terminal, initialize the following system after the cable is reconnected.

System Name	See Procedure
Power Window Control System	IN-32

8. NOTICES**(a) FOR HYBRID SYSTEM ACTIVATION**

- When the warning light is illuminated or the battery has been disconnected and reconnected, pressing the power switch may not start the system on the first try. If so, press the power switch again.
- With the power switch's power mode changed to ON (IG), disconnect the battery. If the key is not in the key slot during reconnection, DTC B2799 may be output.

PARTS LOCATION

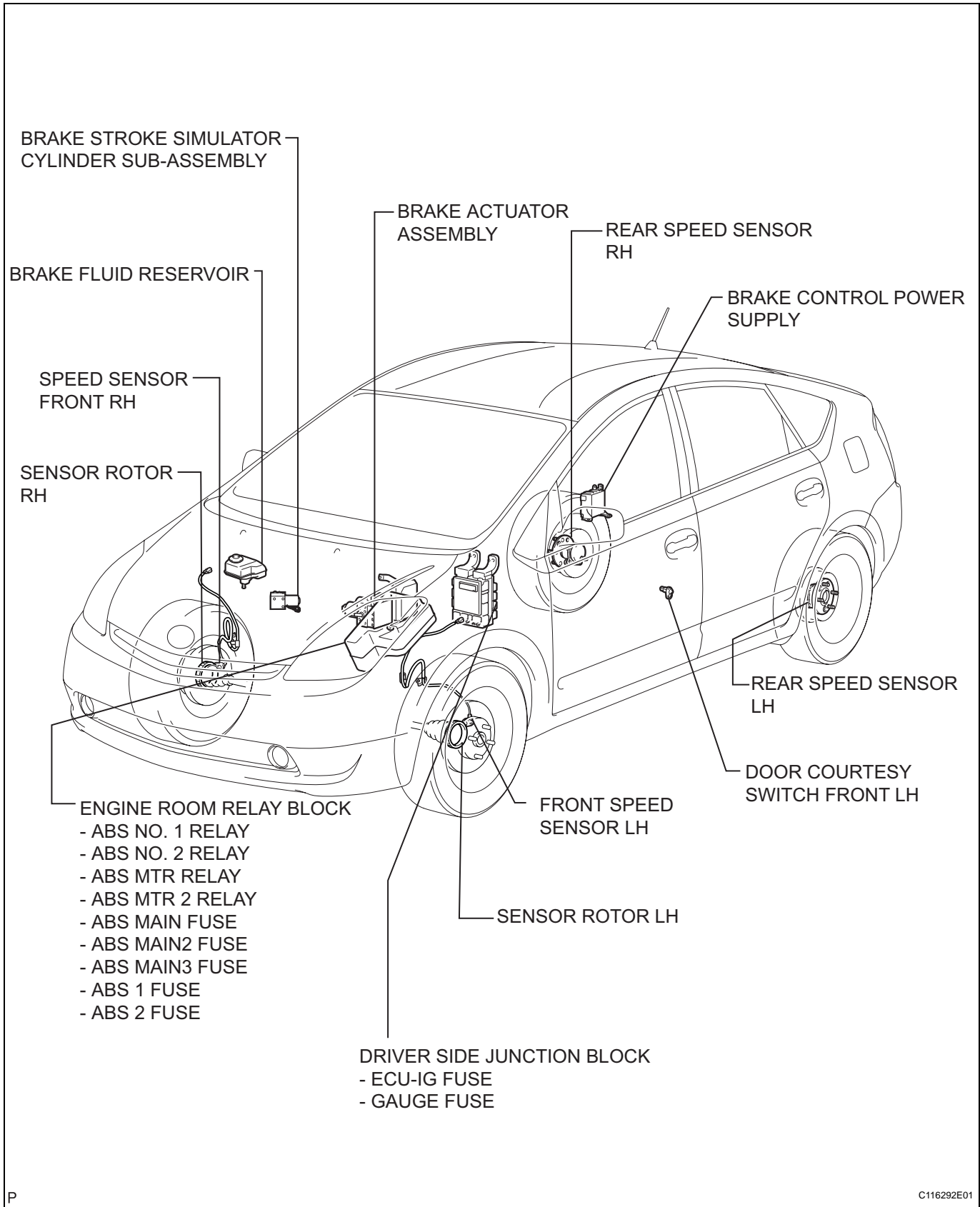

BC

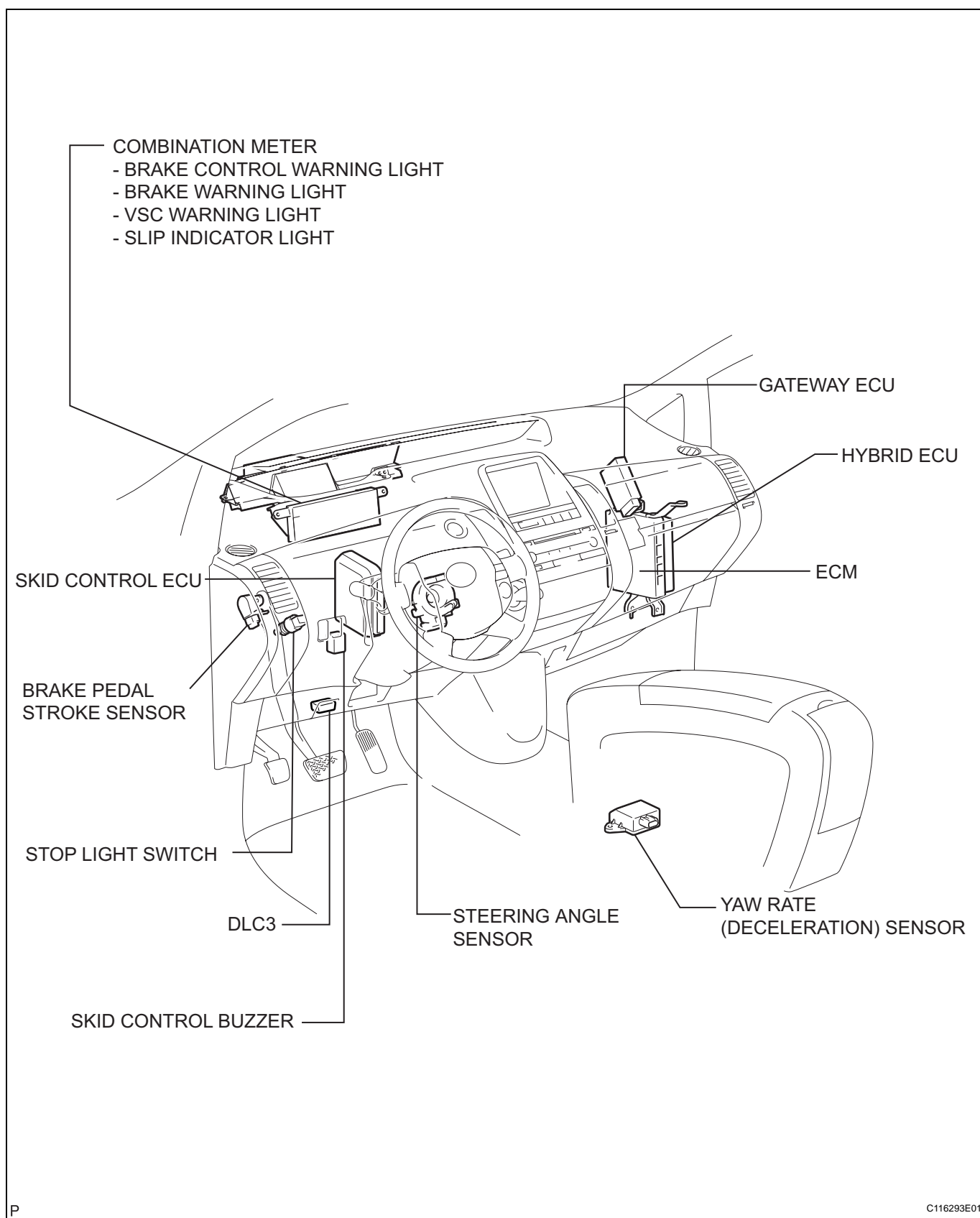

SYSTEM DIAGRAM

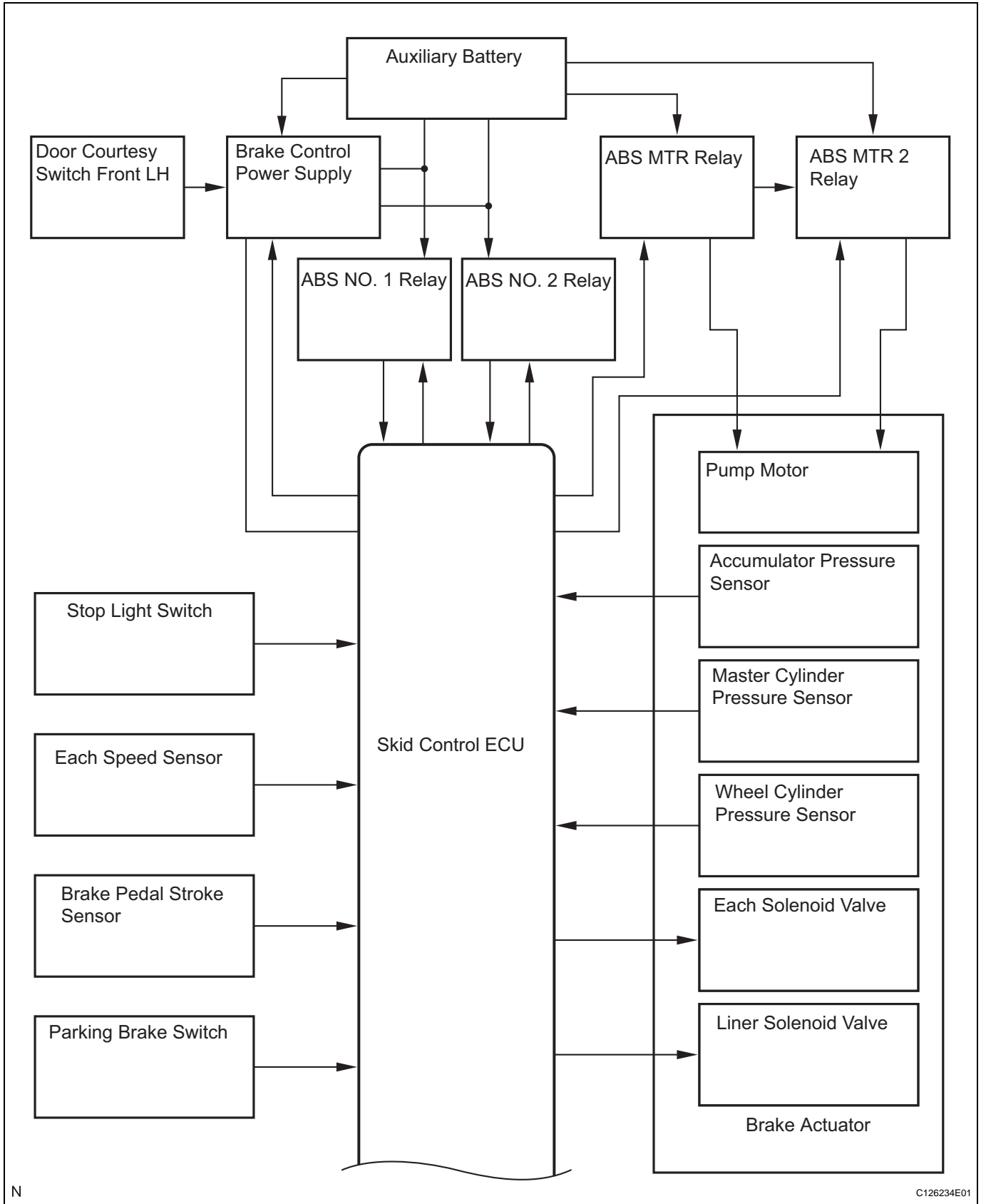

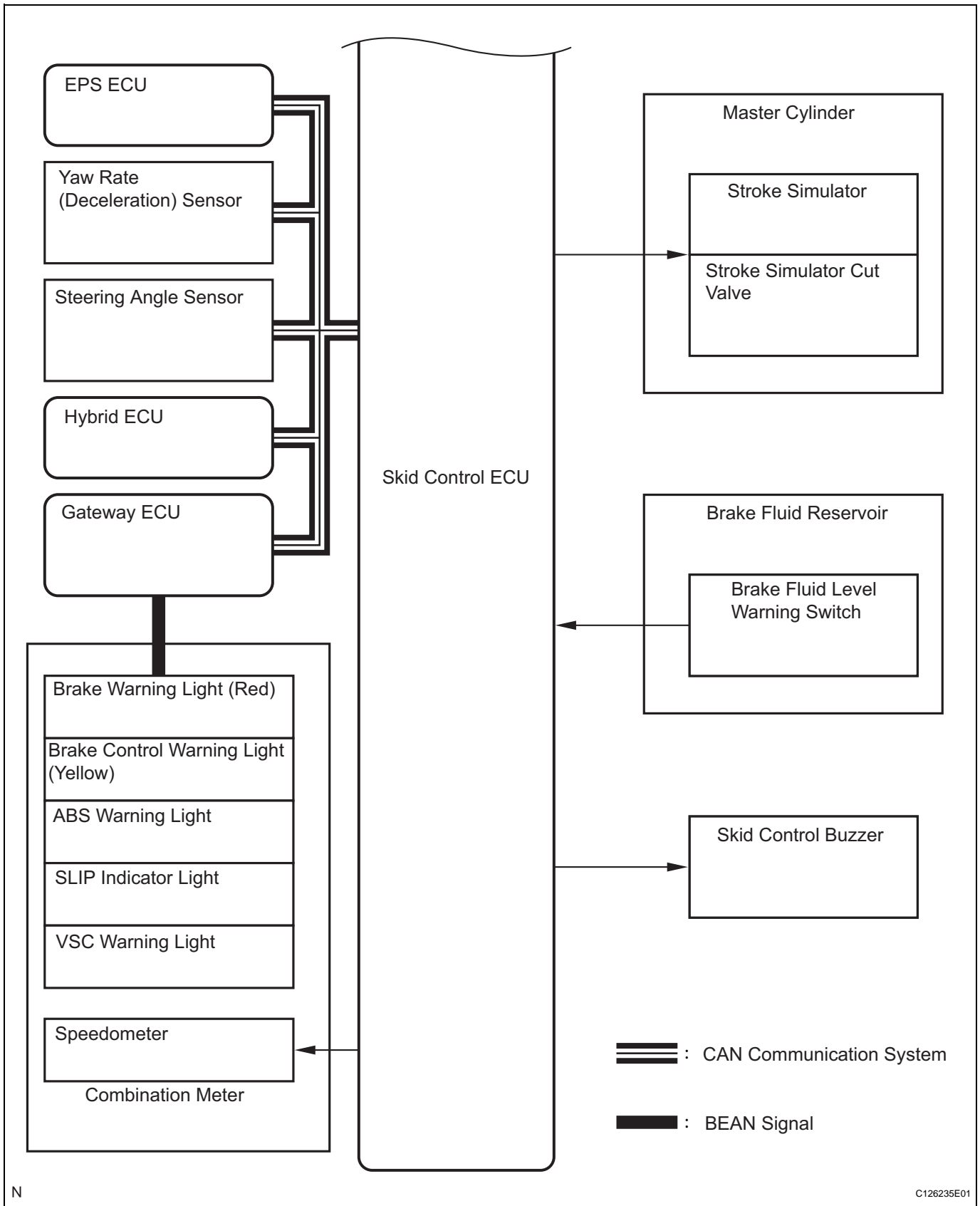

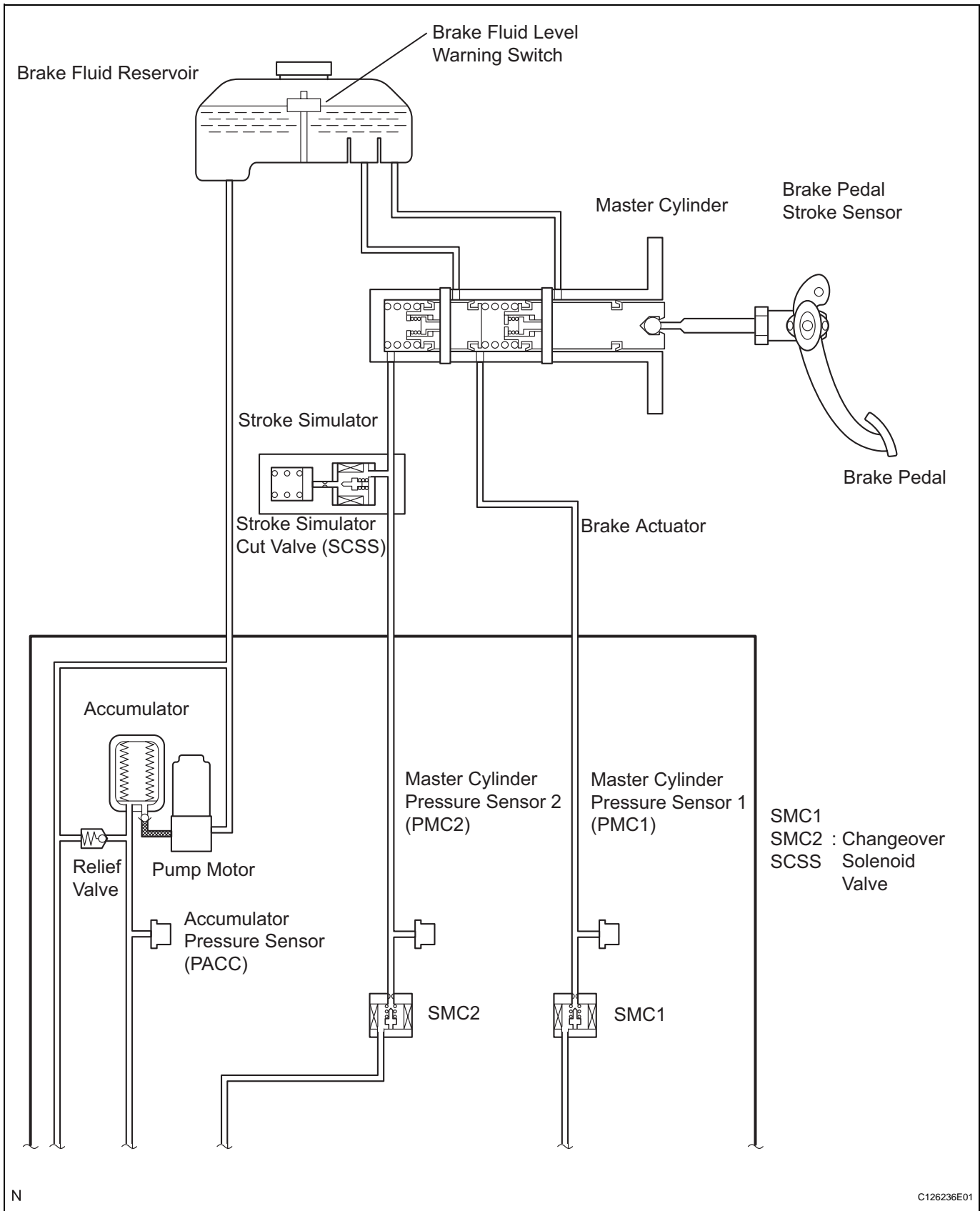

BC

N

C126236E01

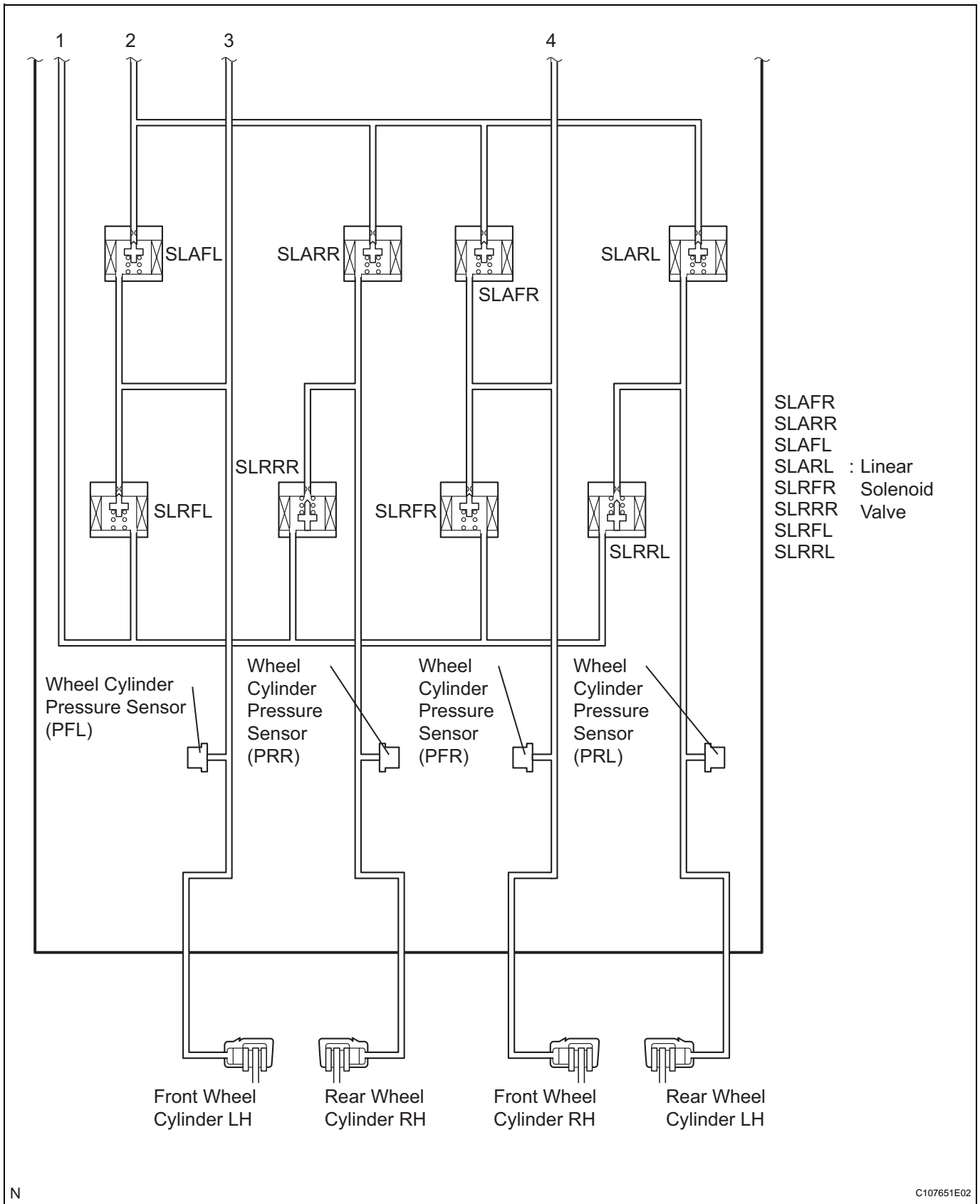

BC

N

C107651E02

Sender	Receiver	Signal	Line
Skid Control ECU	Gateway ECU	Warning signal	CAN communication
Skid Control ECU	Hybrid Control ECU	Vehicle wheel lock signal	CAN communication
Skid Control ECU	Hybrid Control ECU	Vehicle wheel speed sensor signal	CAN communication

Sender	Receiver	Signal	Line
Skid Control ECU	Hybrid Control ECU	Enhanced VSC, torque control signal	CAN communication
Skid Control ECU	Hybrid Control ECU	ABS operation signal	CAN communication
Skid Control ECU	Hybrid Control ECU	Cruise control cancel demand signal	CAN communication
Skid Control ECU	Hybrid Control ECU	Communication error signal (from HV to ECB)	CAN communication
Skid Control ECU	Hybrid Control ECU	Demand drive torque signal	CAN communication
Skid Control ECU	Hybrid Control ECU	Brake torque signal	CAN communication
Skid Control ECU	Hybrid Control ECU	Regeneration performing demand signal	CAN communication
Skid Control ECU	Hybrid Control ECU	STP SW signal	CAN communication
Skid Control ECU	Hybrid Control ECU	STP SW open signal	CAN communication
Skid Control ECU	Hybrid Control ECU	Parking brake signal	CAN communication
Skid Control ECU	Yaw Rate (Deceleration) Sensor	Yaw rate (deceleration) signal	CAN communication
Skid Control ECU	EPS ECU	Steering signal	CAN communication
Hybrid Control ECU	Skid Control ECU	Regeneration prohibit signal	CAN communication
Hybrid Control ECU	Skid Control ECU	Regeneration deterioration notice signal	CAN communication
Hybrid Control ECU	Skid Control ECU	Regeneration error signal	CAN communication
Hybrid Control ECU	Skid Control ECU	Performing torque recognition signal	CAN communication
Hybrid Control ECU	Skid Control ECU	Performing torque recognition signal	CAN communication
Hybrid Control ECU	Skid Control ECU	Destination signal	CAN communication
Hybrid Control ECU	Skid Control ECU	Throttle opening angle signal	CAN communication
Hybrid Control ECU	Skid Control ECU	Accelerator information signal (Idle SW)	CAN communication
Hybrid Control ECU	Skid Control ECU	Communication error signal (from ECB to HV)	CAN communication
Hybrid Control ECU	Skid Control ECU	Wheel lock braking start signal	CAN communication
Hybrid Control ECU	Skid Control ECU	Shift information signal	CAN communication
Hybrid Control ECU	Skid Control ECU	Ready condition signal	CAN communication
Hybrid Control ECU	Skid Control ECU	Braking torque demand signal	CAN communication
Hybrid Control ECU	Skid Control ECU	SLIP indicator ON demand signal	CAN communication

SYSTEM DESCRIPTION

1. COMPONENTS AND FUNCTION

Components	Functions
Skid control ECU*	Calculates brake control in accordance with sensor / ECU signals or communication with hybrid ECU
Brake control power supply assembly*	Charges capacitor inside unit and supplies power source to system by discharging when voltage of vehicle's power source drops
Speed sensor	Detects speed of each wheel and inputs data into skid control ECU
Pedal stroke sensor*	Detects brake pedal stroke and inputs data into skid control ECU
Yaw rate / deceleration sensor*	Detects forward / rearward and lateral acceleration, and then inputs data into skid control ECU
Steering angle sensor	Detects steering wheel angle and steering wheel direction, and then inputs data into skid control ECU
Accumulator	Accumulates fluid pressure generated by pump
Accumulator pressure sensor (PACC)	Detects accumulator pressure and inputs data into skid control ECU
Master cylinder	Generates pressure according to pedal effort
Brake fluid reservoir	Stores master cylinder system / power supply system brake fluid Brake fluid level warning switch built into reservoir detects decrease of brake fluid
Stroke simulator	Generates smooth pedal stroke in accordance with pedal effort during system control
Stroke simulator cut valve (SCSS)	Changes intake / cutoff of brake fluid from master cylinder to stroke simulator Sends oil pressure generated in master cylinder to stroke simulator during system control Cuts brake fluid flow from master cylinder to stroke simulator when system is not controlling
Master cylinder pressure sensor 1 (PMC) Master cylinder pressure sensor 2 (PMC2)	Detects fluid pressure inside master cylinder and inputs data into skid control ECU
Relief valve	Releases brake fluid into reservoir and prevents excessively high power supply system pressure when pump operates continuously due to malfunctions in parts such as accumulator oil pressure sensor
Wheel cylinder pressure sensor	Detects pressure in each wheel cylinder and inputs data into skid control ECU
ABS NO. 1 relay ABS NO. 2 relay	Supplies power to each solenoid according to skid control ECU signals Supplies power to skid control ECU Supplies electricity and maintains operating condition for brake system when power switch is OFF
ABS MTR relay ABS MTR 2 relay	Supplies power to each motor according to skid control ECU signals Drives relay 1 under normal condition and drives relay 2 under ABS operation Substitutes relay operation when one relay malfunctions
Changeover solenoid valve (SMC1, SMC2)	Changeover solenoid valve switches brake hydraulic pressure passage depending on whether system is in operation or not operation
Linear solenoid valve (SLA##, SLR##)	Controls wheel cylinder hydraulic pressure according to regenerative braking force in order to generate braking force required by driver under normal brake operation Controls hydraulic pressure of each wheel cylinder under ABS, VSC brake operation SLA## adjusts pressure increase level SLR## adjusts pressure decrease level
Stop light switch	Illuminates brake light when brake pedal is depressed (sends brake ON signal to skid control ECU)
BRAKE warning light (Red)	Informs driver that there is trouble with ECB (normal brake) by turning on Informs driver when parking brake is applied and brake fluid level drops by turning on

Components	Functions
BRAKE warning light ((Yellow) Brake Control warning light)	Informs driver when there is trouble with ECB or problem with brake system that has no influence on driving, by turning on
ABS warning light	Informs driver that there is trouble with ABS by illuminating light
VSC warning light	Informs driver that there is trouble with Enhanced VSC by illuminating light
SLIP indicator	Informs driver that Enhanced VSC and ABS are operating by blinking light
Skid control buzzer	Informs driver when there is trouble with hydraulic pressure source or power source by continuous buzzer sound Informs that Enhanced VSC is operating by intermittent buzzer sound

HINT:

*: The "initialization of linear solenoid valve and calibration" must be performed when the skid control ECU, actuator, stroke sensor, yaw rate (deceleration) sensor, brake control power supply assembly, and steering sensor are replaced (see page [BC-19](#)). It is necessary to perform zero point calibration of the yaw rate (deceleration) sensor (see page [BC-21](#)).

2. OPERATION DESCRIPTION

(a) ECB (Electronically Controlled Brake):

The skid control ECU receives signals from the pedal stroke sensor, master cylinder sensor and wheel cylinder pressure sensor. Based on these signals, the skid control ECU calculates necessary braking force for each wheel. The necessary hydraulic pressure braking force signal is sent to the hybrid control ECU via CAN communication. The skid control ECU receives a braking force (regenerative braking force) signal from the hybrid control motor via CAN communication. The ECU calculates the necessary hydraulic pressure braking force based on the necessary braking force and regenerative braking force.

Necessary hydraulic pressure is supplied to each wheel by adjusting the brake accumulator (hydraulic pressure source) pressure with each solenoid valve. If there is a problem with the braking function, the normally operating parts will maintain brake control as a fail-safe.

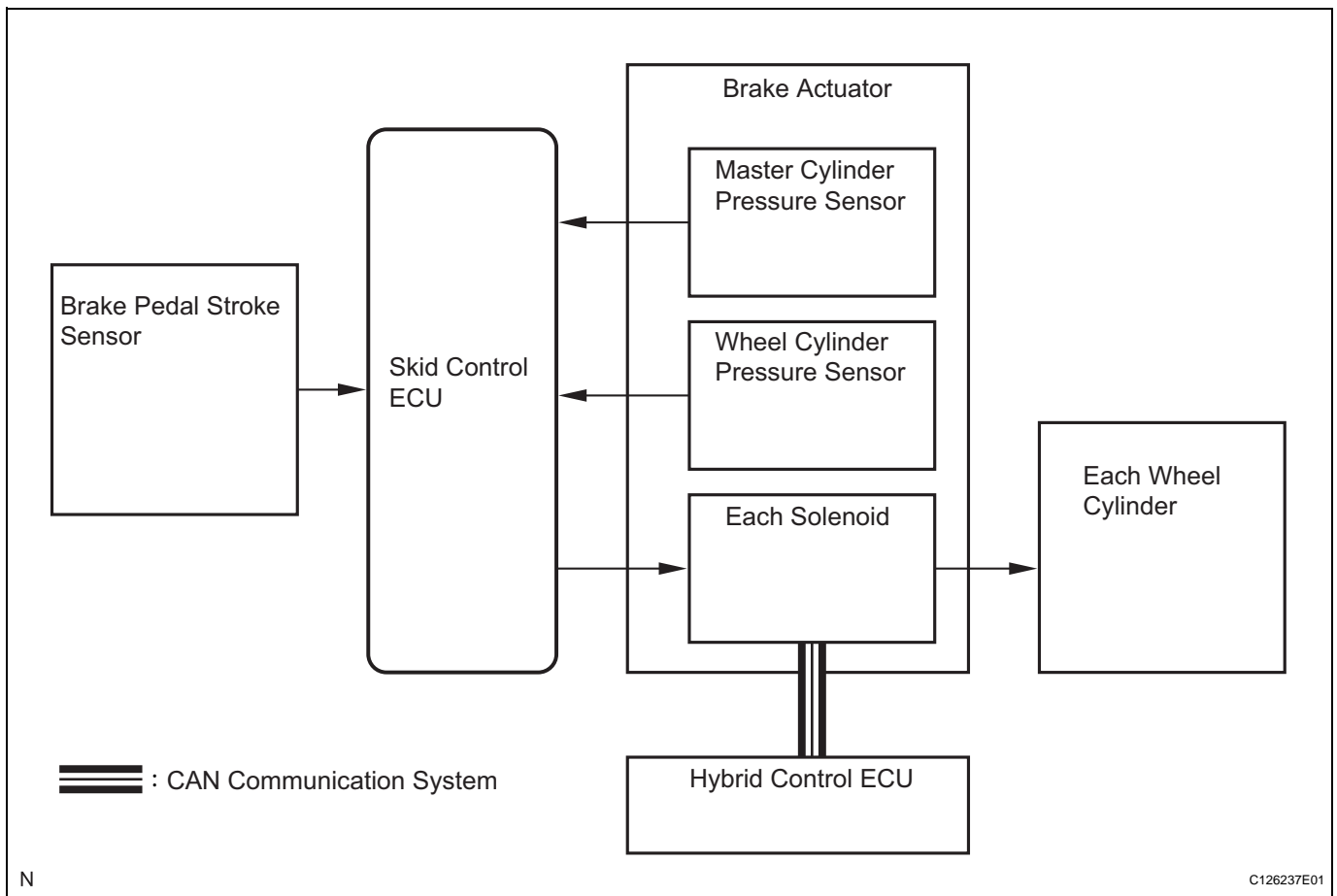

- (b) ABS with EBD and Enhanced VSC:
The skid control ECU receives a vehicle speed signal from each speed sensor and detects wheel's slip condition and then sends a control signal to the solenoid.
The solenoid valve controls each wheel cylinder's hydraulic pressure and optimizes hydraulic pressure allocation to each wheel cylinder.

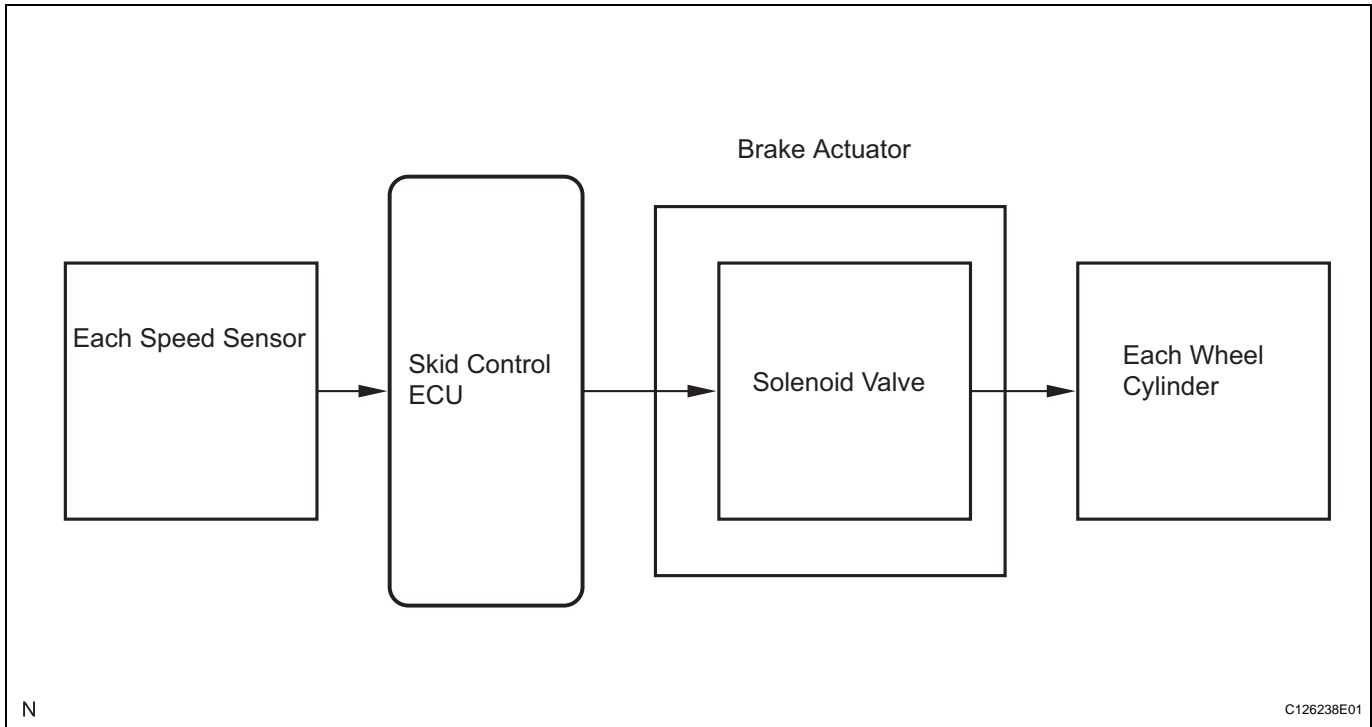

- (c) BA (Brake Assist):
The skid control ECU receives the brake pedal stroke sensor signal and hydraulic pressure signal from the master cylinder pressure sensor and determines whether brake assist operation is necessary or not. If it is determined that brake assist operation is necessary, the ECU changes target hydraulic pressure applied to each wheel.

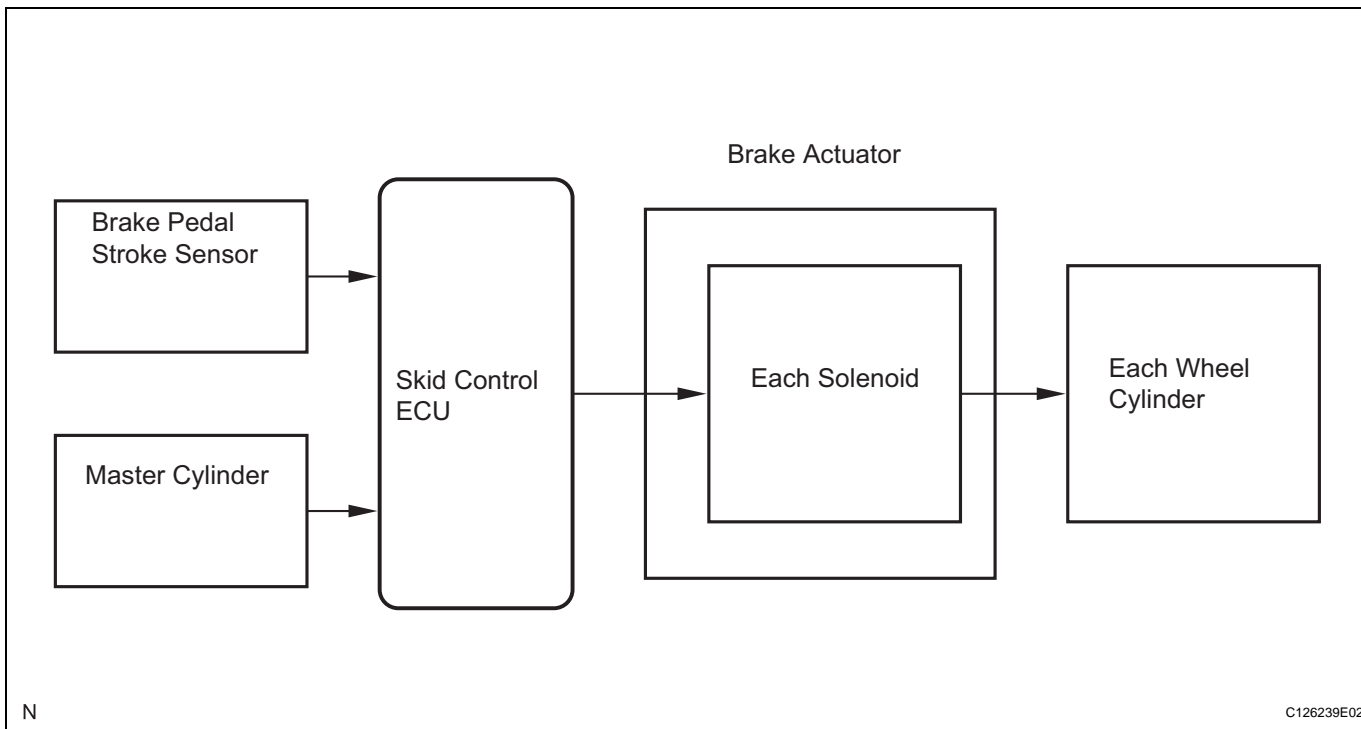

HOW TO PROCEED WITH TROUBLESHOOTING

HINT:

- Use these procedures to troubleshoot the electronically controlled brake system.
- *: Use the intelligent tester.

1 VEHICLE BROUGHT TO WORKSHOP

NEXT

2 CUSTOMER PROBLEM ANALYSIS

NEXT

3 CHECK DTC AND FREEZE FRAME DATA*

NEXT

4 CLEAR DTC AND FREEZE FRAME DATA*

NEXT

5 PROBLEM SYMPTOM CONFIRMATION

Result

Result	Proceed to
Symptom does not occur	A
Symptom occur	B

B

GO TO STEP 7

A

6 SYMPTOM SIMULATION

NEXT

7 CHECK FOR DTC*

Result

Result	Proceed to
There is no output	A
There is output	B

B **GO TO STEP 9**

A

8 **PROBLEM SYMPTOMS TABLE**

NEXT

CHECK FOR FLUID LEAKAGE AND GO TO STEP 11

9 **SYMPTOM SIMULATION**

NEXT

10 **DTC CHART**

NEXT

11 **CIRCUIT INSPECTION***

NEXT

12 **IDENTIFICATION OF PROBLEM**

NEXT

13 **REPAIR OR REPLACE**

NEXT

14 **CONFIRMATION TEST***

NEXT

END

CHECK FOR INTERMITTENT PROBLEMS

1. CHECK FOR INTERMITTENT PROBLEMS

HINT:

A momentary interruption (open circuit) in the connectors and / or wire harness between the sensors and ECUs can be detected in the ECU data monitor function of the intelligent tester.

- (a) Turn the power switch OFF and connect the intelligent tester (with CAN VIM) to the DLC3.

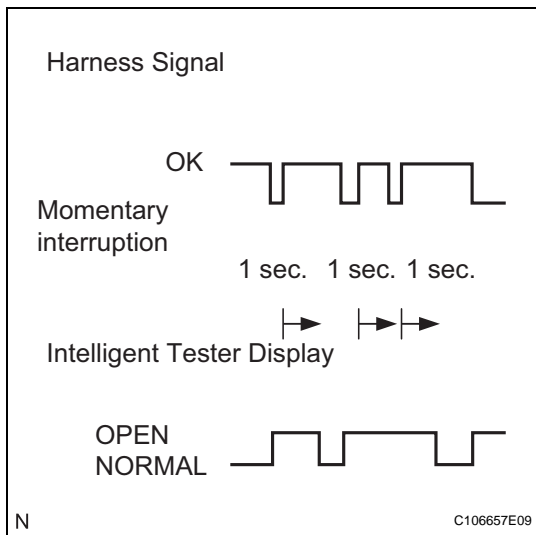
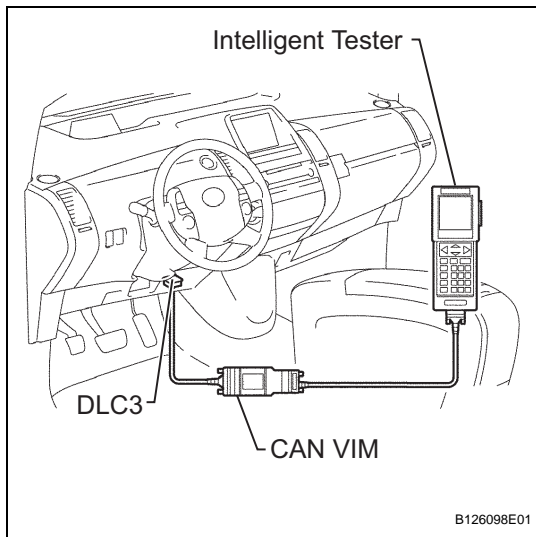

- (b) Turn the power switch ON (READY). Follow the on-screen directions on the intelligent tester (with CAN VIM) to display the DATA LIST and select areas where momentary interruption should be monitored.

HINT:

A momentary interruption (open circuit) cannot be detected for 3 seconds after the power switch is turned ON (READY) (initial check).

Item	Measurement Item / Range (Display)	Normal Condition	Diagnostic Note
SPD SEN FR	FR speed sensor open detection / OPEN or NORMAL	NORMAL: Normal condition	-
SPD SEN FL	FL speed sensor open detection / OPEN or NORMAL	NORMAL: Normal condition	-
SPD SEN RR	RR speed sensor open detection / OPEN or NORMAL	NORMAL: Normal condition	-
SPD SEN RL	RL speed sensor open detection / OPEN or NORMAL	NORMAL: Normal condition	-
YAWRATE SEN	Yaw rate sensor open detection	NORMAL: Normal condition	-
DECELE SEN	G sensor open detection	NORMAL: Normal condition	-

Item	Measurement Item / Range (Display)	Normal Condition	Diagnostic Note
STEERING SEN	Steering sensor open detection	NORMAL: Normal condition	-
M/C SEN 1	Master cylinder pressure sensor 1 open detection	NORMAL: Normal condition	-
M/C SEN 2	Master cylinder pressure sensor 1 open detection	NORMAL: Normal condition	-
STROKE SEN 1	Pedal stroke 1 open	NORMAL: Normal condition	-
FR W/C SEN	FR wheel cylinder open	NORMAL: Normal condition	-
FL W/C SEN	FL wheel cylinder open	NORMAL: Normal condition	-
RR W/C SEN	RR wheel cylinder open	NORMAL: Normal condition	-
RL W/C SEN	RL wheel cylinder open	NORMAL: Normal condition	-
HV COM	HV communication open detection	NORMAL: Normal condition	-
ACC SEN	Accumulator pressure sensor open detection	NORMAL: Normal condition	-

HINT:

- If the status remains on, check the continuity between the ECU and the sensors, or between ECUs.
- The OPEN display on the intelligent tester remains on for 1 second after the harness signal changes from momentary interruption (open circuit) to normal condition.

- (c) While observing the screen, gently jiggle the connector or wire harness between the ECU and sensors, or between ECUs.

Result:

Display does not change.

HINT:

The connector and / or wire harness will have momentary interruptions (open circuit) if the chart fluctuates. Repair or replace connector and / or wire harness as one of them is faulty.

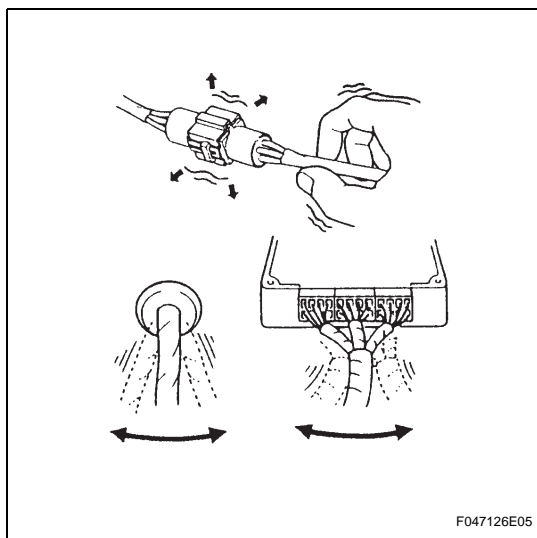

F047126E05

INITIALIZATION

1. INITIALIZATION OF LINEAR SOLENOID VALVE AND CALIBRATION

HINT:

- Perform "initialization of linear solenoid valve and calibration" when the skid control ECU, brake actuator or brake pedal stroke sensor is replaced.
- First perform the pedal stroke sensor zero point calibration and then "initialization of linear solenoid valve and calibration" when the brake stroke sensor is removed / installed or the brake pedal height is adjusted (see page [BR-22](#)).
- First bleed air and then perform initialization of linear solenoid valve and calibration when the brake actuator is replaced.
- "Initialization of linear solenoid valve and calibration" cannot be performed again once it is stored unless the data is cleared or damaged. Perform "initialization of linear solenoid valve and calibration" after the stored value is initialized, except when replacing the skid control ECU.
- DTC C1259/59 is stored and ECB control is partly prohibited when the power switch is turned ON (READY) while the service plug grip of the HV battery is removed, preventing "initialization of linear solenoid valve and calibration" from being normally performed. In this case, connect the service plug grip with the power switch OFF and turn the power switch ON (READY) again to cancel the warning (ECB control prohibition).
- If there is a problem with auxiliary battery (12 V) voltage, "initialization of linear solenoid valve and calibration" cannot be completed normally. Make sure to check battery voltage before performing "initialization of linear solenoid valve and calibration".
- If the actuator's temperature is high, "initialization of linear solenoid valve and calibration" may not be completed normally. In that case, wait until the temperature decreases and then perform "initialization of linear solenoid valve and calibration".
- Do not depress the brake pedal during the "initialization of linear solenoid valve and calibration" procedure.

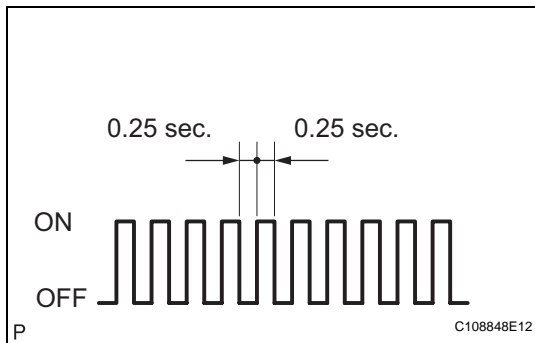
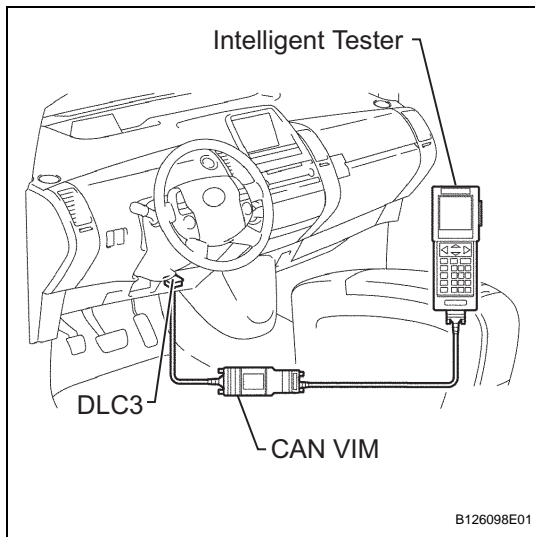

- (a) Clear stored value of "initialization of linear solenoid valve and calibration".
 - (1) Connect the intelligent tester (with CAN VIM) to the DLC3 with the power switch OFF.
 - (2) Turn the power switch ON (READY) with the brake pedal released.
 - (3) Check that the P position switch indicator (P) is on.
 - (4) Turn the intelligent tester ON and clear the stored value of "initialization of linear solenoid valve and calibration" following the screen.
- (b) Perform "initialization of linear solenoid valve and calibration".
 - (1) Connect the intelligent tester to the DLC3 with the power switch OFF.
 - (2) Turn the power switch ON (READY) with the brake pedal released.
 - (3) Check that the main switch (parking switch) indicator (P) is on.
 - (4) Turn the power switch ON (READY) with the brake pedal depressed to display the READY indicator on the meter.
 - (5) Select the SIGNAL CHECK following the intelligent tester screen.
 - (6) Leave the vehicle stationary without depressing the brake pedal for 1 to 2 minutes. Check that the interval between blinks of the Brake Control warning light (BRAKE warning (Yellow)) changes from 1 second to 0.25 seconds.

NOTICE:

- Leave the meter's "READY" indicator on during the "initialization of linear solenoid valve and calibration". Do not drive the vehicle or depress the brake pedal.
- A DTC that indicates trouble with "initialization of linear solenoid valve and calibration" is stored if entering the TEST MODE with the shift lever in any position other than P.

HINT:

- The time needed to complete "initialization of linear solenoid valve and calibration" varies depending on battery voltage.
- The Brake Control warning light (BRAKE warning (Yellow)) blinks at 1 second intervals during the "initialization of linear solenoid valve and calibration" and changes to the TEST MODE display when it is completed.
- The Brake Control warning light (BRAKE warning (Yellow)) blinks at 0.25 second intervals if the TEST MODE is normal.

- (7) Check that DTC C1346/66 that indicates trouble with stroke sensor zero point learning is not output when the Brake Control warning light changes to the TEST MODE display upon "initialization of linear solenoid valve and calibration" completion.
- (8) Enter the NORMAL MODE from the SIGNAL CHECK following the intelligent tester screen.

2. YAW RATE SENSOR / DECELERATION SENSOR INITIALIZATION

HINT:

The zero point data of the yaw rate/deceleration sensor stored in the skid control ECU must be cleared when the yaw rate/deceleration sensor is replaced (see page [BC-21](#)).

CALIBRATION

1. DESCRIPTION

- (a) Zero point calibration is not performed until the data is cleared when the zero point is once stored. Zero point calibration should be performed after the zero point is cleared if the yaw rate (deceleration) sensor is replaced.
- (b) Steering sensor zero point calibration is automatically performed with the vehicle driving straight.
- (c) Follow the chart to perform calibration.

Replacing Parts	Necessary Operation
Skid Control ECU	Yaw rate (deceleration) sensor zero point calibration.
Yaw Rate (Deceleration) Sensor	1. Clearing zero point calibration data. 2. Yaw rate sensor and deceleration sensor zero point calibration.

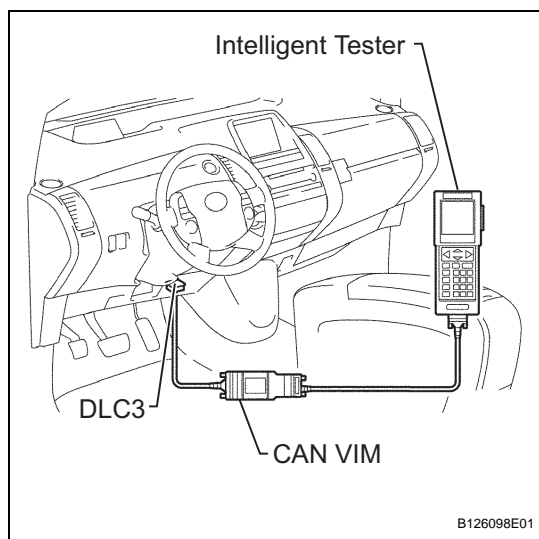

2. CLEAR ZERO POINT CALIBRATION

- (a) Clearing the DTCs.
 - (1) Connect the intelligent tester (with CAN VIM) to the DLC3.
 - (2) Turn the power switch ON (READY).
 - (3) Operate the intelligent tester (with CAN VIM) to erase the codes.
- HINT:
Refer to the intelligent tester Operator's Manual for further details.

3. PERFORM ZERO POINT CALIBRATION OF YAW RATE SENSOR AND DECELERATION SENSOR

NOTICE:

- While obtaining the zero point, do not vibrate the vehicle by tilting, moving or shaking it and keep it in a stationary condition. Do not start the engine.
 - Be sure to do this on a level surface (with an inclination less than 1 degree).
- (a) Check that the steering wheel is in the centered position and move the shift lever to the P position.
 - (b) Connect the intelligent tester (with CAN VIM) to the DLC3.
 - (c) Turn the power switch ON (READY).
 - (d) Operate the intelligent tester (with CAN VIM) to test mode.
 - (e) Obtain the zero point of the yaw rate sensor and deceleration sensor.
 - (1) Keep the vehicle in the stationary condition on a level surface for 2 seconds or more.
 - (2) Check that the VSC warning light blinks.
- HINT:
- If the VSC warning light does not blink, perform the zero point calibration again.
 - The zero point calibration is performed only once after the system enters the test mode.
 - Calibration cannot be performed again until the stored data is cleared once.
- (f) Turn the power switch OFF.

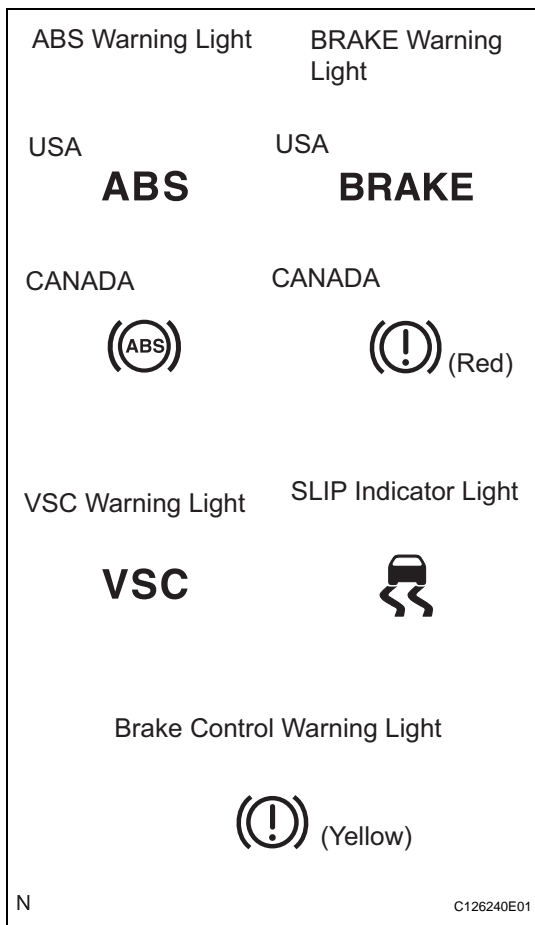

TEST MODE PROCEDURE

1. CHECK WARNING LIGHT AND INDICATOR LIGHT

- (a) Release the parking brake pedal.

NOTICE:

When releasing the parking brake, move the P position switch into the P position to hold the vehicle for safety.

HINT:

When the parking brake is applied or the level of the brake fluid is low, the BRAKE warning light comes on.

- (b) When the power switch is ON (READY), check that the ABS warning light, VSC warning light, BRAKE warning light, Brake Control warning light and SLIP indicator light come on for approximately 3 seconds.

HINT:

- If the indicator check result is not normal, proceed to troubleshooting for the ABS warning light circuit, VSC warning light circuit, BRAKE warning light circuit, Brake Control warning light circuit or SLIP indicator light circuit.
- If the indicator remains on, proceed to troubleshooting for the light circuit below.

Trouble Area	See procedure
ABS warning light circuit	BC-170
VSC warning light circuit	BC-171
BRAKE warning light circuit	BC-176
Brake Control warning light circuit	BC-182
SLIP indicator light circuit	BC-187

2. CHECK SENSOR SIGNAL BY TEST MODE

HINT:

- Set the vehicle in the TEST MODE and perform the following procedures to check operation of the deceleration sensor, master cylinder pressure sensor, speed sensor and yaw rate sensor.
- Check results are indicated by DTCs output only in the TEST MODE.
- Perform the following procedures (step 1 to step 5) as a set.
- When entering the test mode, the skid control ECU records all the test mode codes and clears the codes judged to be normal.
- During test mode, Enhanced VSC does not operate regardless of whether or not the sensor check result is normal or if there is a malfunction.
- When the mode returns to the normal mode, all the test mode codes are cleared.
- The ABS warning light and VSC warning light comes on if the sensor has a malfunction.

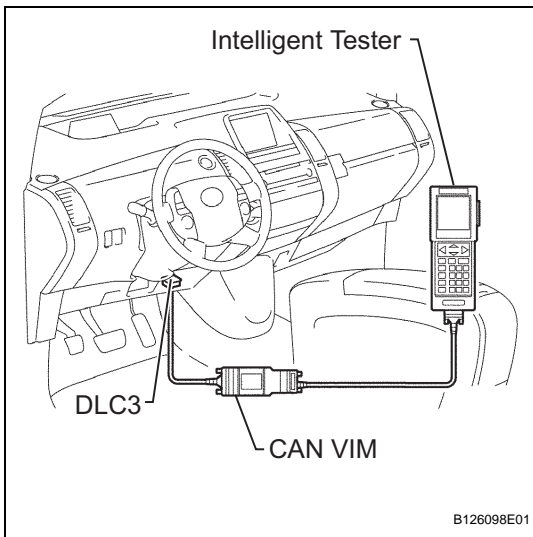

- (a) Step 1: Procedures for test mode
- (1) Turn the power switch OFF.
 - (2) Connect the intelligent tester (with CAN VIM) to the DLC3.
 - (3) Check that the steering wheel is in the centered position and move the shift lever to the P position.
 - (4) Turn the power switch ON (READY).

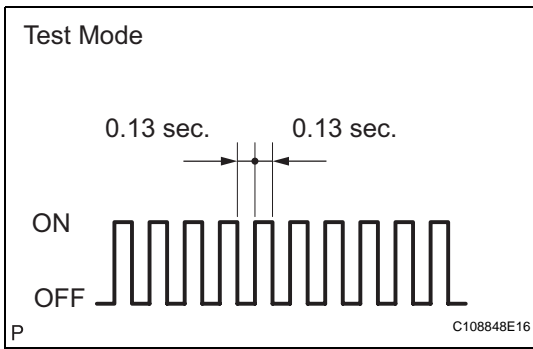

- (5) Select the SIGNAL CHECK following the intelligent tester screen.
- (6) Check that the ABS warning light and VSC warning light indicates TEST MODE.
HINT:
If the ABS warning light and VSC warning light do not blink, inspect the ABS warning light circuit and VSC warning light circuit.

Trouble Area	See Procedure
ABS warning light circuit	BC-170
VSC warning light circuit	BC-175

- (7) Start the engine.
- (b) Step 2: Check deceleration sensor
 - (1) Check that the ABS warning light is blinking in TEST MODE.
 - (2) Keep the vehicle in the stationary condition on a level surface for 1 second or more.
HINT:
The blinking pattern of the ABS warning light and VSC warning light do not change. When the sensor is normal and in the test mode, if the above conditions are met, the check is completed.

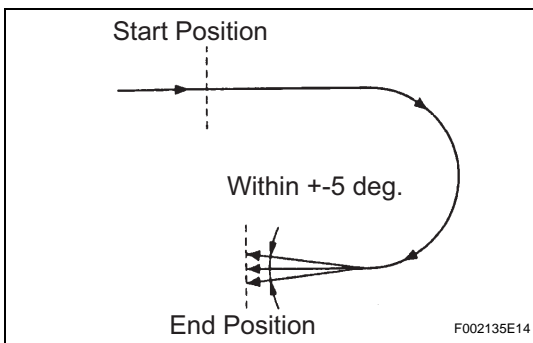

- (c) Step 3: Check yaw rate sensor
 - (1) Shift the shift lever to the D range and drive the vehicle at the vehicle speed of approx. 5 km/h (3 mph), turn the steering wheel either to left or right 90° or more, and drive in a half-circle pattern.
NOTICE:
 - The vehicle direction at the end should be 180 +/- 5 ° or less.
 - While turning do not move the shift lever to the P position. Do not turn the power switch OFF.
 - HINT:
 - The turning direction is not important.

- Turning should be completed within 2.0 seconds. However, it is possible to change the vehicle speed, stop or more backward.
- (2) Stop the vehicle and move the shift lever to the P position, check that the skid control buzzer sounds for 3 seconds.

HINT:

- If the skid control buzzer sounds, the sensor check is completed normally.
 - If the skid control buzzer does not sound, check the skid control buzzer circuit (see page [BC-191](#)), then perform the sensor check again.
 - If the skid control buzzer still will not sound, there is a malfunction in the Enhanced VSC sensor, so check the DTC.
 - Drive the vehicle in a half-circle pattern. At the end of the turn, the direction of the vehicle should be within $180 \pm 5^\circ$ of its start position.
 - Do not spin the wheels.
- (d) Step 4: Check master cylinder pressure sensor
- (1) Check that the ABS warning light is blinking in TEST MODE.
 - (2) Leave the vehicle in a stationary condition and the brake pedal in a free condition for 1 second or more, and quickly depress the brake pedal with a force of 98 N (10 kgf, 22 lbf) or more for 1 second or more.
 - (3) While the vehicle is stopped, release the brake pedal.
 - (4) While the vehicle is stopped, quickly depress the brake pedal once or more and check the ABS warning light is lit for 3 seconds.

HINT:

- While the ABS warning light is lit, maintain the condition a brake pedal load of approximately 98 N or more is applied.
- During the test mode, the ABS warning light comes on for 3 seconds every time the above pedal operation.
- If the master cylinder pressure sensor check is not completed, randomly depressing the brake pedal will cause the negative pressure to decrease further and the sensor check will be difficult to be completed.
- If the negative pressure is insufficient, the master cylinder pressure sensor check may not be completed. In this case, turn the engine idle to make the negative pressure sufficient.
- Strongly depress the brake pedal when the negative pressure is insufficient. The brake warning light may come on with the fail-safe function.

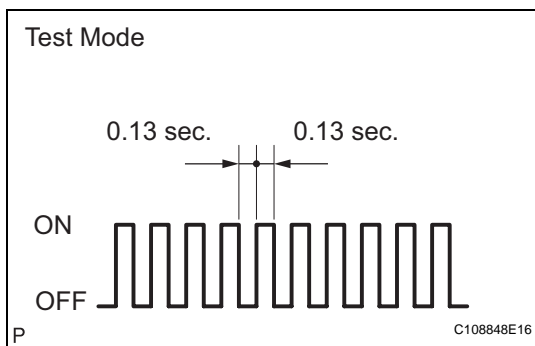

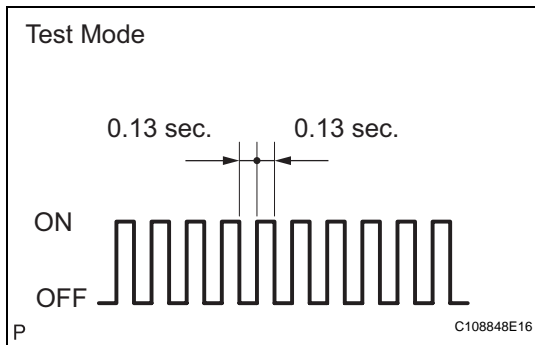

- (e) Step 5: Check speed sensor
- (1) Check the ABS warning light is blinking of TEST MODE.
 - (2) Start the sensor signal check.
 - (3) Drive the vehicle straight forward. Drive the vehicle at a speed of 45 to 80 km/h (28 to 50 mph) or higher for several seconds and check that the ABS warning light goes off.

Vehicle Speed	Test	Check
0 to 45 km/h (0 to 28 mph)	Low speed test	Response of sensors
45 to 80 km/h (28 to 50 mph)	Middle speed test	Deviations of sensor signal

NOTICE:

- Before the speed sensor check, the yaw rate sensor, deceleration sensor and master cylinder pressure sensor checks should be completed.
- Before the speed sensor check, the yaw rate sensor, deceleration sensor and master cylinder pressure sensor checks should be completed.
- After the warning light goes off, driving at 50 mph (80 km/h) or more will cause the test mode codes to be recorded again, before the speed reaches at 50 mph (80 km/h), decelerate and stop the vehicle.
- If the sensor check is not completed, the ABS warning light blinks even while driving and the ABS does not operate.

HINT:

If the speed sensor check is completed, the ABS warning light does not come on while driving and blinks at test mode when the vehicle stops.

- (f) Step 6: Check end of sensor
- (1) If the sensor check is completed, the ABS warning light blinks (test mode) when the vehicle stops and the warning light is off when the vehicle is driving.

NOTICE:

- When the yaw rate sensor, deceleration sensor, speed sensor and master cylinder pressure sensor checks are completed, the sensor check is completed.
- If the sensor check is not completed, the ABS warning light blinks even while the vehicle is driving and the ABS does not operate.
- If a DTC is detected during the test mode, the ABS warning light and VSC warning light comes on.

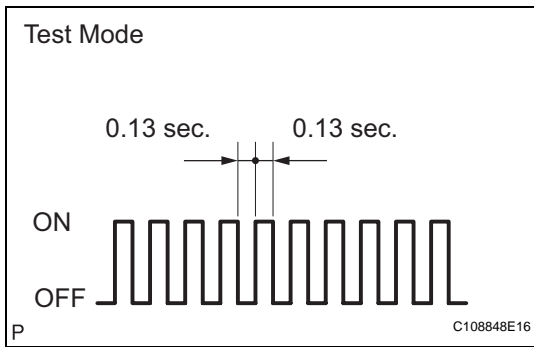

(g) Step 7: Read test mode

(1) Using intelligent tester (with CAN VIM), check the DTCs in the test mode (refer to step 8).

NOTICE:

- If only the DTCs are displayed, repair the malfunctioning area and clear the DTC. Check if the ABS warning light and VSC warning light are normal.
- If only the test mode codes are displayed, perform the test mode again.
- If DTCs or test mode codes are displayed, repair the malfunction area, clear the DTCs and perform the test mode inspection.

HINT:

- The test mode codes and DTCs are displayed.
- If the ABS is normal, the ABS warning light comes on for 0.25 seconds and goes off for 0.25 seconds repeatedly.

(h) Step 8: DTC of test mode

DTC of ABS sensor check function

Code No.	Diagnosis	Trouble Area
C1271/71	Low output voltage of right front speed sensor	<ul style="list-style-type: none"> • Right front speed sensor • Sensor installation • Sensor rotor
C1272/72	Low output voltage of left front speed sensor	<ul style="list-style-type: none"> • Left front speed sensor • Sensor installation • Sensor rotor
C1273/73	Low output voltage of right rear speed sensor	<ul style="list-style-type: none"> • Right rear speed sensor • Sensor installation • Sensor rotor
C1274/74	Low output voltage of left rear speed sensor	<ul style="list-style-type: none"> • Left rear speed sensor • Sensor installation • Sensor rotor
C1275/75	Abnormal change in output voltage of right front speed sensor	Right front sensor rotor
C1276/76	Abnormal change in output voltage of left front speed sensor	Left front speed sensor rotor
C1277/77	Abnormal change in output voltage of right rear speed sensor	Right rear sensor rotor
C1278/78	Abnormal change in output voltage of left rear speed sensor	Left rear speed sensor rotor
C1279/79	Deceleration sensor is faulty	<ul style="list-style-type: none"> • Yaw rate (Deceleration) sensor • Sensor installation
C1281/81	Master cylinder pressure sensor output signal is faulty	Master cylinder pressure sensor
C0371/71	Signal malfunction	Yaw rate sensor (Deceleration sensor)

HINT:

The code in this table are output only in test mode.

PROBLEM SYMPTOMS TABLE

HINT:

Use the table below to help determine the cause of the problem symptom. The potential causes of the symptoms are listed in order of probability in the "Suspected area" column of the table. Check each symptom by checking the suspected areas in the order they are listed. Replace parts as necessary.

Electronically controlled brake system

Symptom	Suspected area	See page
ABS does not operate, BA does not operate, EBD does not operate	1. Check the DTC again and make sure that the normal code is output.	BC-38
	2. IG power source circuit and ground circuit	BC-84
	3. Front speed sensor circuit	BC-54
	4. Rear speed sensor circuit	BC-61
	5. Check the brake actuator with an intelligent tester (with CAN VIM). (Check brake actuator operation using the ACTIVE TEST (Check brake actuator operation using the ACTIVE TEST function.) If abnormal, check the hydraulic circuit for leakage.	BC-205
	6. If the symptoms still occur even after the above suspected areas are inspected and proved to be normal, replace the skid control ECU.	-
ABS does not operate efficiently, BA does not operate efficiently, EBD does not operate efficiently	1. Check the DTC again and make sure that the normal code is output.	BC-38
	2. Front speed sensor circuit	BC-54
	3. Rear speed sensor circuit	BC-61
	4. Stop light switch circuit	BC-104
	5. Check the brake actuator with an intelligent tester. If abnormal, check the hydraulic circuit for leakage.	BC-205
	6. If the symptoms still occur even after the above suspected areas are inspected and proved to be normal, replace the skid control ECU.	-
ABS warning light abnormal (Remains on)	1. ABS warning light circuit	BC-166
	2. Skid control ECU	-
ABS warning light abnormal (Does not come on)	1. ABS warning light circuit	BC-170
	2. Skid control ECU	-
DTC of ABS check cannot be done	1. Check the DTC again and make sure that the normal code is output.	BC-38
	2. TC and CG terminal circuit	BC-194
	3. If the symptoms still occur even after the above suspected areas are inspected and proved to be normal, replace the skid control ECU.	-
Sensor signal check cannot be done	1. TS and CG terminal circuit	BC-198
	2. Skid control ECU	-

Symptom	Suspected area	See page
VSC does not operate	1. Check the DTC again and make sure that the normal code is output.	BC-38
	2. IG power source circuit and ground circuit	BC-84
	3. Check the hydraulic circuit for leakage.	-
	4. Front speed sensor circuit	BC-54
	5. Rear speed sensor circuit	BC-61
	6. Yaw rate / Deceleration sensor circuit	BC-70
	7. Steering sensor circuit	BC-75
	8. If the symptoms still occur even after the above suspected areas are inspected and proved to be normal, replace the skid control ECU.	-
SLIP indicator light abnormal	1. SLIP indicator light circuit	BC-187
	2. Skid control ECU	-
DTC of VSC check cannot be done	1. Check the DTC again and make sure that the normal code is output.	BC-38
	2. TC terminal circuit	BC-194
	3. If the symptoms still occur even after the above suspected areas are inspected and proved to be normal, replace the skid control ECU.	-
VSC warning light abnormal (Remains on)	1. Check the DTC again and make sure that the normal code is output.	BC-38
	2. VSC warning circuit	BC-171
	3. If the symptoms still occur even after the above suspected areas are inspected and proved to be normal, replace the skid control ECU.	-
VSC warning light abnormal (Does not come on)	1. Check the DTC again and make sure that the normal code is output.	BC-38
	2. VSC warning circuit	BC-175
	3. If the symptoms still occur even after the above suspected areas are inspected and proved to be normal, replace the skid control ECU.	-
Brake Control warning light abnormal (Remains on)	1. Check the DTC again and make sure that the normal code is output.	BC-38
	2. Brake Control warning circuit	BC-182
	3. If the symptoms still occur even after the above suspected areas are inspected and proved to be normal, replace the skid control ECU.	-
Brake Control warning light abnormal (Does not come on)	1. Check the DTC again and make sure that the normal code is output.	BC-38
	2. Brake Control warning circuit	BC-186
	3. If the symptoms still occur even after the above suspected areas are inspected and proved to be normal, replace the skid control ECU.	-

TERMINALS OF ECU

1. CHECK BATTERY VOLTAGE

- (a) Measure the battery voltage.

Standard voltage:
10 to 14 V

2. CHECK SKID CONTROL ECU

- (a) Measure the voltage and resistance between each terminal or between each terminal and the body ground.
- (b) Connect the intelligent tester (with CAN VIM) to the DLC3, and check the communication condition with the skid control ECU.
- (c) Using an oscilloscope, check that the pulse generates between each terminal or between each terminal and the body ground.

NOTICE:

- Each inspection should be performed from the back of the connector with the connector connected to the skid control ECU.
- The voltage between the terminals of the brake actuator assembly may become 0 V due to the fail-safe function when the ECB warning light comes on (malfunctioning).

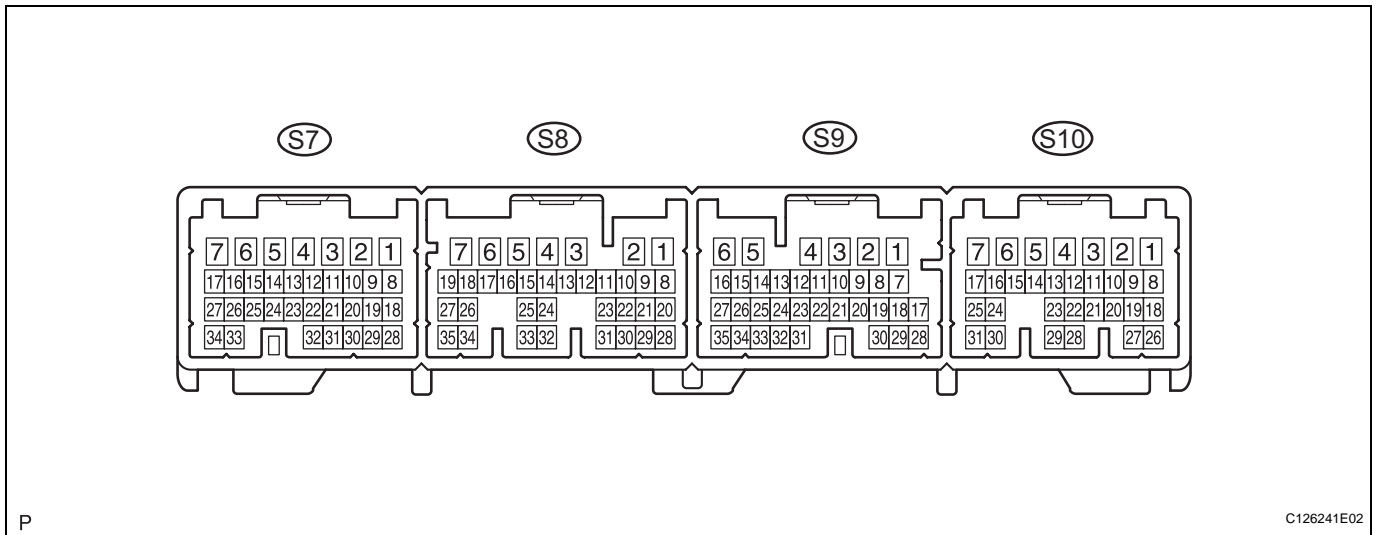

P

C126241E02

HINT:

Inspect the ECU from the wire harness side while the connector is connected.

Symbols (Terminal No.)	Wiring Color	Terminal Description	Condition	Specified Condition
R1+ (S7-2) - GND (S7-1)	P - W	Main relay power 1	Push power switch ON (READY)	9.1 to 13.6 V
BS1 (S7-3) - GND (S7-1)	B - W	Battery source 1	Push power switch ON (READY) Approx. 1.5 sec. after pushing power switch ON (READY)	8.8 to 14 V

Symbols (Terminal No.)	Wiring Color	Terminal Description	Condition	Specified Condition
SMC1 (S7-4) - GND (S7-1)	Y - W	Master cut solenoid 1 output	Push power switch ON (READY) Brake pedal depressed approx. 1.5 sec. after pushing power switch ON (READY)	Below 1.5 V
+BCTY (S7-5) - GND (S7-1)	V - W	Courtesy power input	Driver door open → close	Approx. 5 sec. 8 to 16 V → Below 1 V
SLAFR- (S7-6) - GND (S7-1)	W - W	FR solenoid (-) output	Push power switch ON (READY) Approx. 1.5 sec. after pushing power switch ON (READY)	Below 1.5 V
SLAFR+ (S7-7) - GND (S7-1)	R - W	FR solenoid (+) output	Push power switch ON (READY) Brake pedal depressed approx. 1.5 sec. after pushing power switch ON (READY)	Pulse generation (see waveform 1)
E (S7-8) - GND (S7-1)	L - W	Pressure sensor ground	Push power switch OFF	Below 1 Ω
VCM1 (S7-9) - GND (S7-1)	P - W	Pressure sensor power	Push power switch ON (READY)	4.75 to 5.25 V
MR1+ (S7-11) - GND (S7-1)	GR - W	Motor relay power 1	Push power switch ON (READY) Approx. 1.5 sec. after pushing power switch ON (READY)	8.8 to 14 V
SR1 (S7-12) - GND (S7-1)	L - W	Main relay output 1	Push power switch ON (READY) Approx. 1.5 sec. or more after pushing power switch ON (READY)	Below 1 V
SCSS (S7-13) - GND (S7-1)	BR - W	Stroke simulator cut solenoid output	Push power switch ON (READY) Brake pedal depressed	Below 1.5 V
SLARL+ (S7-15) - GND (S7-1)	L - W	RL solenoid (+) output	Push power switch ON (READY) Brake pedal depressed approx. 1.5 sec. after pushing power switch ON (READY)	Pulse generation (see waveform 1)
SLRRL+ (S7-16) - GND (S7-1)	W - W	RL solenoid (+) output	Push power switch ON (READY) Brake pedal depressed approx. 1.5 sec. after pushing power switch ON (READY)	Pulse generation (see waveform 1)
SLRFR+ (S7-17) - GND (S7-1)	Y - W	FR solenoid (+) output	Push power switch ON (READY) After approx. 1.5 sec., brake pedal depressed → released	Pulse generation (see waveform 2)
PRL (S7-18) - GND (S7-1)	G - W	RL pressure sensor input	Push power switch ON (READY) Brake pedal released	0.3 to 0.8 V
SG1 (S7-20) - GND (S7-1)	BR - W	Pressure sensor shield ground 1	Push power switch OFF	Below 1 Ω
PACC (S7-21) - GND (S7-1)	W - W	Accumulator pressure sensor input	Push power switch ON (READY) After pump motor operates and stops by pedal operation	3.3 to 4.7 V
FR- (S7-22) - GND (S7-1)	L - W	FR sensor (-) input	Push power switch OFF	Below 1 Ω

Symbols (Terminal No.)	Wiring Color	Terminal Description	Condition	Specified Condition
PFR (S7-23) - GND (S7-1)	Y - W	FR pressure sensor input	Push power switch ON (READY) Brake pedal released	0.3 to 0.8 V
MR1 (S7-25) - GND (S7-1)	L - W	Motor relay output 1	Push power switch ON (READY) Pump motor is operating	Below 1.5 V
SLRRL- (S7-26) - GND (S7-1)	P - W	RL solenoid (-) output	Push power switch ON (READY) Approx. 1.5 sec. after pushing power switch ON (READY)	Below 1.5 V
SLARL- (S7-27) - GND (S7-1)	LG - W	RL solenoid (-) output	Push power switch ON (READY) Approx. 1.5 sec. after pushing power switch ON (READY)	Below 1.5 V
MTT (S7-29) - GND (S7-1)	R - W	Motor test input	Push power switch ON (READY) Pump motor is operating	3.5 V or higher
PMC1 (S7-30) - GND (S7-1)	R - W	Master pressure sensor input 1	Push power switch ON (READY) Brake pedal released	0.3 to 0.8 V
PCK1 (S7-31) - GND (S7-1)	B - W	Pressure sensor check output 1	Push power switch ON (READY) Approx. 1.5 sec. after pushing power switch ON (READY)	4.75 to 5.25 V
FR+ (S7-32) - GND (S7-1)	P - W	FR sensor (+) input	Vehicle speed input	Pulse generation (see waveform 3)
SLRFR- (S7-34) - GND (S7-1)	B - W	FR solenoid (-) output	Push power switch ON (READY) Approx. 1.5 sec. after pushing power switch ON (READY)	Below 1.5 V
+BI1 (S8-3) - GND (S8-1, 2)	B - W	Main relay power input 1	Push power switch OFF	10 to 14 V
+BO1 (S8-5) - GND (S8-1, 2)	Y - W	Main relay power output 1	Push power switch ON (IG)	8.8 to 14 V
IG1 (S8-7) - GND (S8-1, 2)	B - W	IG1 power	Push power switch ON (IG)	10 to 14 V
RSS (S8-10) - GND (S8-1, 2)	BR - W	Speed sensor shield ground	Push power switch OFF	Below 1 Ω
BZ (S8-12) - GND (S8-1, 2)	BR - W	Warning buzzer output	Push power switch ON (READY) Buzzer is operating	Below 1 V
STP (S8-14) - GND (S8-1, 2)	R - W	Stop light switch signal input	Push power switch ON (READY) Brake pedal depressed → released	8 to 14 V → Below 1 V
CAN-L (S8-18) - GND (S8-1, 2)	W - W	CAN communication (Send and receive-)	Check DTC using intelligent tester	CAN communication's DTC is not output
CAN-H (S8-19) - GND (S8-1, 2)	B - W	CAN communication (Send and receive+)	Check DTC using intelligent tester	CAN communication's DTC is not output
FAIL (S8-20) - GND (S8-1, 2)	P - W	Capacitor communication (Receive)	Push power switch ON (READY) Approx. 1.5 sec. after pushing power switch ON (READY)	Pulse generation (See waveform 5)
SP1 (S8-22) - GND (S8-1, 2)	V - W	Speed meter output	Vehicle speed input	Pulse generation (See waveform 4)

Symbols (Terminal No.)	Wiring Color	Terminal Description	Condition	Specified Condition
RL- (S8-27) - GND (S8-1, 2)	B - W	RL sensor (-) input	Push power switch OFF	Below 1 Ω
D/G (S8-28) - GND (S8-1, 2)	W - W	Diagnosis output	Push power switch ON (READY)	9.1 to 13.6 V
ENA (S8-30) - GND (S8-1, 2)	B - W	Capacitor communication (Send)	Push power switch ON (READY) Approx. 1.5 sec. after pushing power switch ON (READY)	Pulse generation (See waveform 6)
TS (S8-32) - GND (S8-1, 2)	L - W	Sensor diagnosis check input	Push power switch ON (READY)	Below 1.5 V → 9.1 to 13.6 V
VBZ (S8-33) - GND (S8-1, 2)	B - W	Warning buzzer power	Push power switch ON (READY)	9.1 to 13.6 V
RL+ (S8-35) - GND (S8-1, 2)	W - W	RL sensor (+) input	Vehicle speed input	Pulse generation (See waveform 3)
+BO2 (S9-4) - GND (S9-1, 2)	W - W-B	Main relay power output 2	Push power switch ON (READY)	8.8 to 14 V
+BI2 (S9-5) - GND (S9-1, 2)	R - W-B	Main relay power input 2	Push power switch OFF	10 to 14 V
VCSK (S9-6) - GND (S9-1, 2)	B - W-B	Stroke sensor power	Push power switch ON (READY)	3.75 to 4.95 V
SSK (S9-7) - GND (S9-1, 2)	Shielded - W-B	Stroke sensor shield ground	Push power switch OFF	Below 1 Ω
SKG (S9-8) - GND (S9-1, 2)	W - W-B	Stroke sensor ground	Push power switch OFF	Below 1 Ω
PKB (S9-14) - GND (S9-1, 2)	R - W-B	Parking brake signal input	Parking brake applied → released	Below 1.5 V → 9.1 to 13.6 V
SKS1 (S9-21) - GND (S9-1, 2)	R - W-B	Stroke sensor signal input 1	Push power switch ON (READY) Brake pedal released	0.46 to 1.35 V
SKS2 (S9-22) - GND (S9-1, 2)	G - W-B	Stroke sensor signal input 2	Push power switch ON (READY) Brake pedal released	2.56 to 4.35 V
RR- (S9-23) - GND (S9-1, 2)	B - W-B	RR sensor (-) input	Push power switch OFF	Below 1 Ω
RR+ (S9-31) - GND (S9-1, 2)	W - W-B	RR sensor (+) input	Vehicle speed input	Pulse generation (See waveform 3)
SLAFL+ (S10-1) - GND (S10-4)	P - W-B	FL solenoid (+) output	Push power switch ON (READY) Brake pedal depressed approx. 1.5 sec. after pushing power switch ON (READY)	Pulse generation (See waveform 1)
SLAFL- (S10-2) - GND (S10-4)	O - W-B	FL solenoid (-) output	Push power switch ON (READY) Approx. 1.5 sec. after pushing power switch ON (READY)	Below 1.5 V
SMC2 (S10-3) - GND (S10-4)	LG - W-B	Master cut solenoid 2 output	Push power switch ON (READY) Brake pedal depressed approx. 1.5 sec. after pushing power switch ON (READY)	Below 1.5 V
IG2 (S10-5) - GND (S10-4)	O - W-B	IG2 power	Push power switch ON (READY)	10 to 14 V
LBL (S10-6) - GND (S10-4)	P - W-B	Brake fluid level switch input	Reservoir level switch OFF → ON	4 to 4.65 V → Below 1.5 V

Symbols (Terminal No.)	Wiring Color	Terminal Description	Condition	Specified Condition
BS2 (S10-7) - GND (S10-4)	P - W-B	Battery source 2	Push power switch ON (READY) Approx. 1.5 sec. after pushing power switch ON (READY)	8.8 to 14 V
SLRFL+ (S10-8) - GND (S10-4)	Y - W-B	FL solenoid (+) output	Push power switch ON (READY) After approx. 1.5 sec., brake pedal depressed → released	Pulse generation (See waveform 2)
SLARR- (S10-9) - GND (S10-4)	P - W-B	RR solenoid (-) output	Push power switch ON (READY) Approx. 1.5 sec. after pushing power switch ON (READY)	Below 1.5 V
SG2 (S10-12) - GND (S10-4)	Shielded - W-B	Pressure sensor shield ground 2	Push power switch OFF	Below 1 Ω
FSS (S10-13) - GND (S10-4)	BR - W-B	Speed sensor shield ground	Push power switch OFF	Below 1 Ω
VCM2 (S10-14) - GND (S10-4)	B - W-B	Pressure sensor power 2	Push power switch ON (READY)	4.75 to 5.25 V
SR2 (S10-15) - GND (S10-4)	V - W-B	Main relay output 2	Push power switch ON (READY) Approx. 1.5 sec. after pushing power switch ON (READY)	Below 1 V
R2+ (S10-17) - GND (S10-4)	Y - W-B	Main relay power 2	Push power switch ON (READY)	9.1 to 13.6 V
SLRRR- (S10-18) - GND (S10-4)	BR - W-B	RR solenoid (-) output	Push power switch ON (READY) Approx. 1.5 sec. after pushing power switch ON (READY)	Below 1.5 V
SLARR+ (S10-19) - GND (S10-4)	V - W-B	RR solenoid (+) output	Push power switch ON (READY) Brake pedal depressed approx. 1.5 sec. after pushing power switch ON (READY)	Pulse generation (See waveform 1)
SLRRR+ (S10-20) - GND (S10-4)	R - W-B	RR solenoid (+) output	Push power switch ON (READY) Brake pedal depressed approx. 1.5 sec. after pushing power switch ON (READY)	Pulse generation (See waveform 1)
PCK2 (S10-21) - GND (S10-4)	L - W-B	Pressure sensor check output 2	Push power switch ON (READY)	4.75 to 5.25 V
FL- (S10-22) - GND (S10-4)	G - W-B	FL sensor (-) input	Push power switch OFF	Below 1 Ω
PFL (S10-23) - GND (S10-4)	R - W-B	FL pressure sensor input	Push power switch ON (READY) Brake pedal released	0.3 to 0.8 V
MR2+ (S10-25) - GND (S10-4)	R - W-B	Motor relay power 2	Push power switch ON (READY) Approx. 1.5 sec. after pushing power switch ON (READY)	8.8 to Below 14 V
SLRFL- (S10-26) - GND (S10-4)	L - W-B	FL solenoid (-) output	Push power switch ON (READY) Approx. 1.5 sec. after pushing power switch ON (READY)	Below 1.5 V

Symbols (Terminal No.)	Wiring Color	Terminal Description	Condition	Specified Condition
PMC2 (S10-27) - GND (S10-4)	W - W-B	Master pressure sensor input 2	Push power switch ON (READY) Brake pedal released	0.3 to 0.8 V
FL+ (S10-28) - GND (S10-4)	R - W-B	FL sensor (+) input	Vehicle speed input	Pulse generation (See waveform 3)
E2 (S10-29) - GND (S10-4)	G - W-B	Pressure sensor ground 2	Push power switch OFF	Below 1 Ω
MR2 (S10-30) - GND (S10-4)	G - W-B	Motor relay output 2	Push power switch ON (READY) Pump motor is operating	Below 1.5 V
PRR (S10-31) - GND (S10-4)	Y - W-B	RR pressure sensor input	Push power switch ON (READY) Brake pedal released	0.3 to 0.8 V

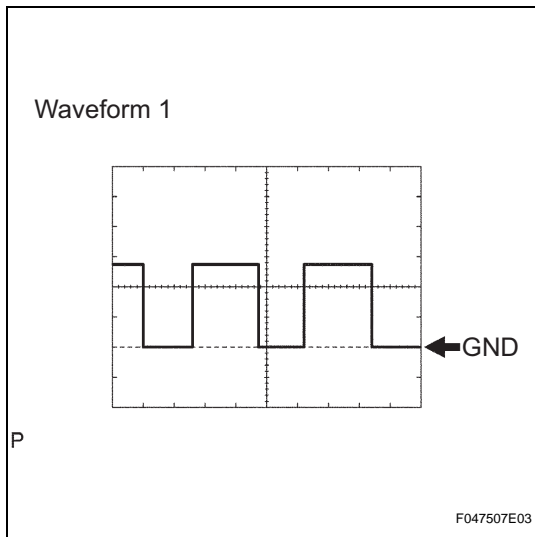

(d) Using an oscilloscope, check the waveform 1.
Waveform 1 (Reference)

Item	Content
Symbols (Terminal No.)	SLAFR+ (S7-7) - GND (S7-1) SLARL+ (S7-15) - GND (S7-1) SLRRL+ (S7-16) - GND (S7-1) SLAFL+ (S10-2) - GND (S10-4) SLARR+ (S10-19) - GND (S10-4) SLRRR+ (S10-20) - GND (S10-4)
Tool Setting	5 V/DIV., 200 msec./DIV.
Condition	Brake pedal depressed

NOTICE:
Normal waveform is output only when BS 1 and 2 voltages are normal (10 to 14 V).

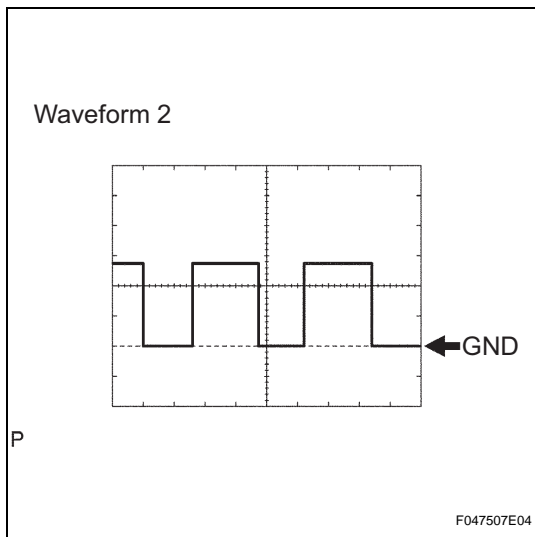

(e) Using an oscilloscope, check the waveform 2.
Waveform 2 (Reference)

Item	Content
Symbols (Terminal No.)	SLRFR+ (S7-17) - GND (S7-1) SLRFL+ (S10-8) - GND (S10-4)
Tool Setting	5 V/DIV., 200 msec./DIV.
Condition	Brake pedal depressed → released

NOTICE:
Normal waveform is output only when BS 1 and 2 voltages are normal (10 to 14 V).

(f) Using an oscilloscope, check the waveform 3.

Waveform 3 (Reference)

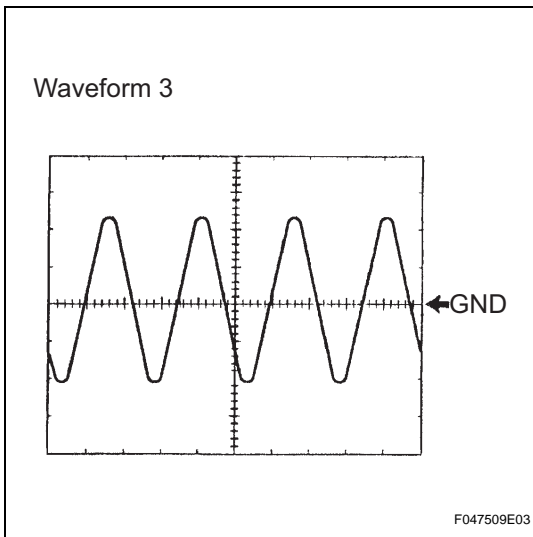

Item	Content
Symbols (Terminal No.)	FR+ (S7-32) - GND (S7-1) RL+ (S8-35) - GND (S8-1, 2) RR+ (S9-31) - GND (S9-1, 2) FL+ (S10-28) - GND (S10-4)
Tool Setting	1 V/DIV., 200 msec./DIV.
Condition	While driving at approximately 18 mph (30 km/h)

NOTICE:

As the vehicle speed (tire rotating speed) becomes faster, the cycle becomes shorter and the output voltage becomes larger.

(g) Using an oscilloscope, check the waveform 4.

Waveform 4 (Reference)

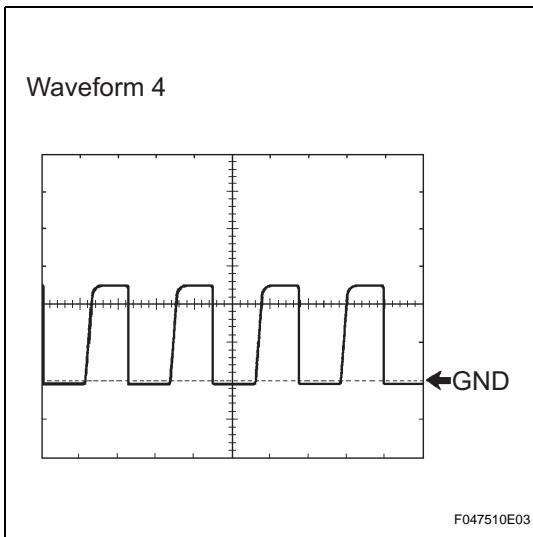

Item	Content
Symbols (Terminal No.)	SP1 (S8-22) - GND (S8-1, 2)
Tool Setting	5 V/DIV., 50 msec./DIV.
Condition	While driving at approximately 12 mph (20 km/h)

NOTICE:

As the vehicle speed (tire rotating speed) becomes faster, the cycle becomes shorter.

(h) Using an oscilloscope, check the waveform 5.

Waveform 5 (Reference)

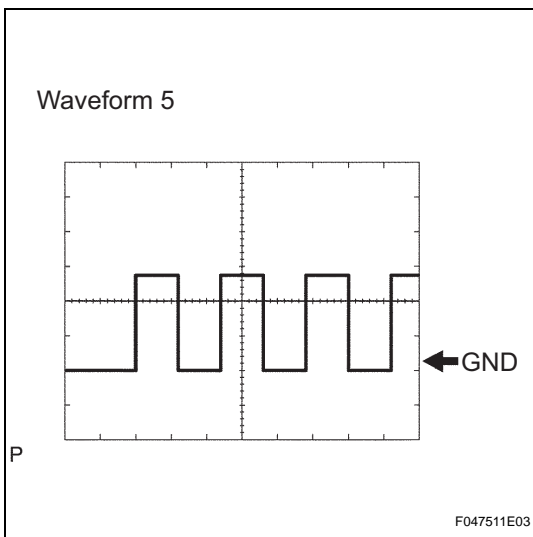

Item	Content
Symbols (Terminal No.)	FAIL (S8-20) - GND (S8-1, 2)
Tool Setting	5 V/DIV., 200 msec./DIV.
Condition	Power switch ON (READY)

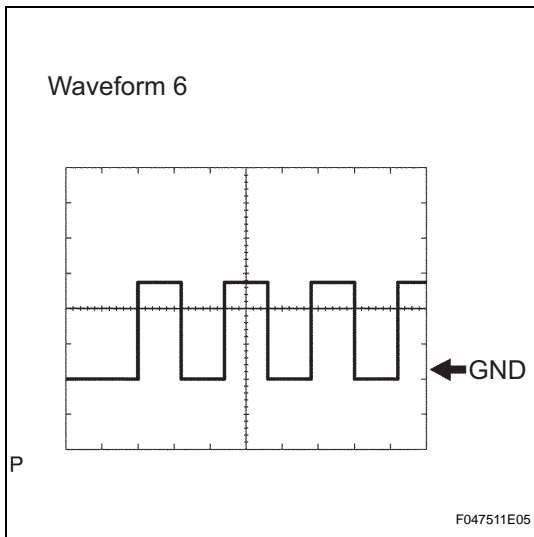

(i) Using an oscilloscope, check the waveform 6.
Waveform 6 (Reference)

Item	Content
Symbols (Terminal No.)	ENA (S8-30) - GND (S8-1, 2)
Tool Setting	5 V/DIV., 100 msec./DIV.
Condition	Power switch ON (READY)

ABS Warning Light	BRAKE Warning Light
USA	USA
ABS	BRAKE
CANADA	CANADA
(ABS)	(!) (Red)
VSC Warning Light	SLIP Indicator Light
VSC	
Brake Control Warning Light	
(!) (Yellow)	

N C126240E01

DIAGNOSIS SYSTEM

1. DIAGNOSIS FUNCTION

On the combination meter, the BRAKE warning light (Red), BRAKE warning light ((Yellow) Brake Control warning light), ABS warning light or VSC warning light come on to inform the driver if trouble occurs in the skid control ECU input signal or actuator system. If there is trouble in the oil pressure source (pump motor, accumulator) or the vehicle power supply is insufficient, the skid control buzzer sounds to warn the driver.

Item	Condition
ABS Warning Light	Comes on when a failure in ABS, EBD or Enhanced VSC occurs
VSC Warning Light	Comes on when a failure in Enhanced VSC occurs
SLIP Indicator Light	Comes on while operating ABS or Enhanced VSC
BRAKE Warning Light ((Yellow) Brake Control Warning Light)	Comes on when a minor failure that does not affect normal driving occurs in the brake control system
BRAKE Warning Light (Red)	Comes on when a failure in the brake control system Comes on when the parking brake is applied or the brake fluid level is low.

2. DIAGNOSIS DISPLAY FUNCTION

DTCs detected by the ECU can be read by connecting the intelligent tester and performing the read command. The DTC has a detailed code that can be checked on the freeze frame data screen.

3. BRAKE SYSTEM DISPLAY INITIAL CHECK

Turn the power switch ON (READY) and check that the ABS warning light, VSC warning light, Brake Control warning light, BRAKE warning light and SLIP indicator light come on, and then go off after approximately 3 seconds.

If any of the lights do not come on, check the bulb and the multiplex communication diagnosis.

DTC CHECK / CLEAR

1. CHECK DTC (When Using Intelligent Tester)

- (a) Connect the intelligent tester (with CAN VIM) to the DLC3.
- (b) Turn the power switch ON (READY).
- (c) Read the DTCs following the prompts on the tester screen.

HINT:

Refer to the intelligent tester operator's manual for further details.

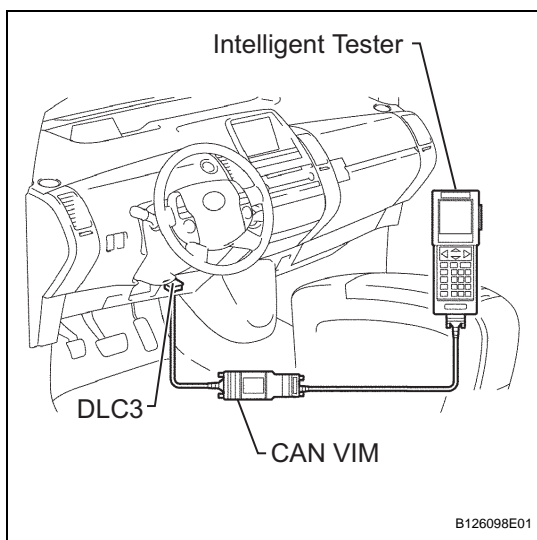

2. CHECK DTC (When not Using Intelligent Tester)

- (a) Using SST, connect terminals TC and CG of the DLC3.

SST 09843-18040

- (b) Turn the power switch ON (READY).

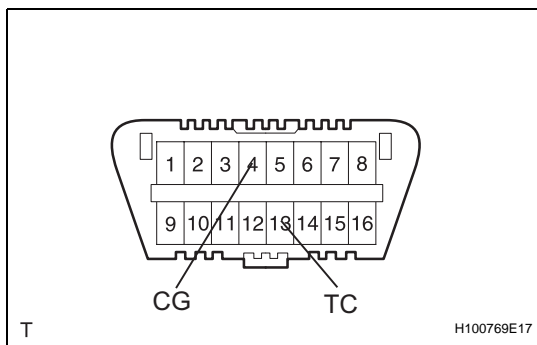

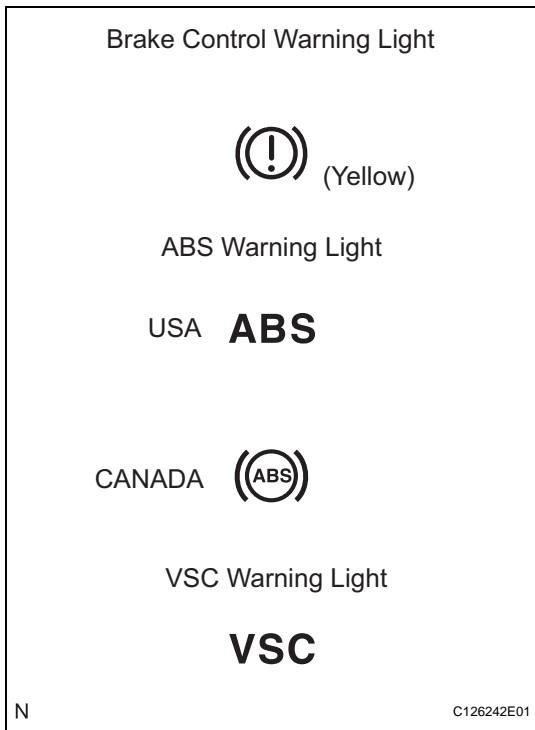

(c) Read the DTC from the Brake Control warning light, ABS warning light and VSC warning light on the combination meter.

Light	Read DTC
Brake Control warning light	DTC of ECB system
ABS warning light	DTC of ABS system
VSC warning light	DTC of Enhanced VSC system

HINT:

- If no code appears, inspect the diagnostic circuit or ABS warning light circuit.

Trouble Area	See procedure
TC and CG terminal circuit	BC-194
Brake Control warning light circuit	BC-182
ABS warning light circuit	BC-166
VSC warning light circuit	BC-171

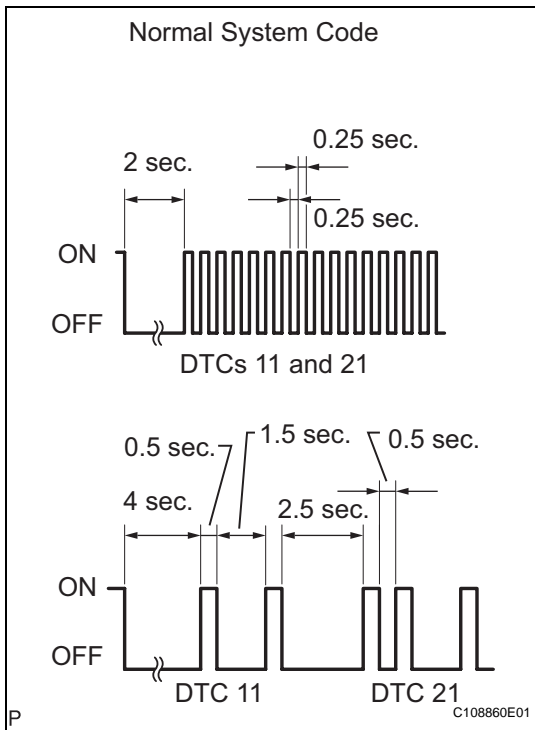

- As an example, the illustration below shows the blinking patterns of the normal system code and trouble codes 11 and 21.

(d) Codes are explained in the Diagnostic Trouble Code (see page [BC-47](#)).

(e) After completing the check, disconnect terminals TC and CG of the DLC3, and turn off the display. If 2 or more DTCs are detected at the same time, the DTCs will be displayed in ascending order.

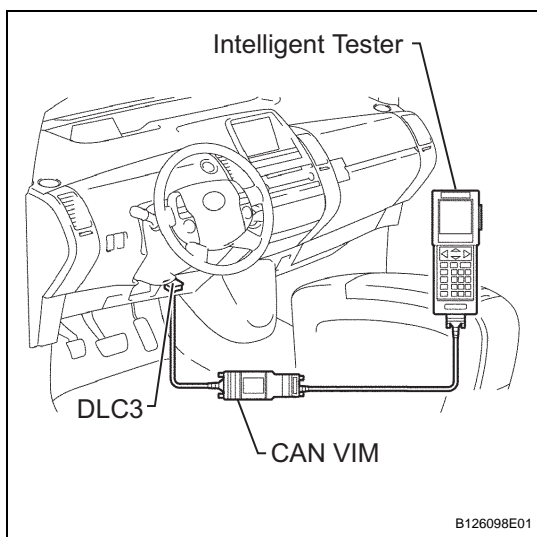

3. CLEAR DTC (When Using Intelligent Tester)

- (a) Connect the intelligent tester (with CAN VIM) to the DLC3.
- (b) Turn the power switch ON (READY).
- (c) Operate the intelligent (with CAN VIM) tester to clear the codes.

HINT:

Refer to the intelligent tester operator's manual for further details.

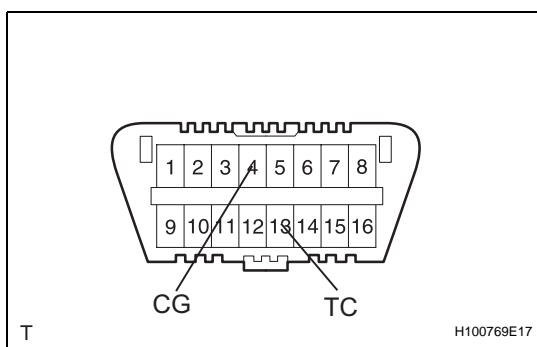

4. CLEAR DTC (When not Using Intelligent Tester)

- (a) Using SST, connect terminals TC and CG of the DLC3.

SST 09843-18040

- (b) Turn the power switch ON (READY).

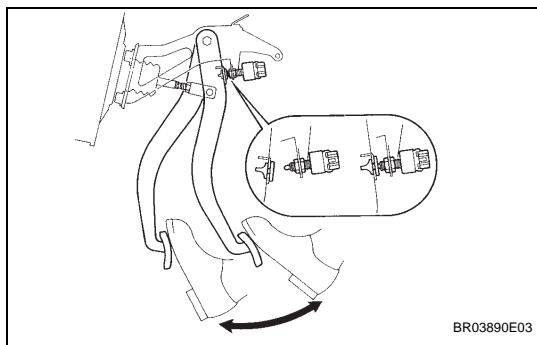

- (c) Clear the DTCs stored in the ECU by depressing the brake pedal 8 times or more within 5 seconds.
- (d) Check that the warning light indicates a normal system code.
- (e) Remove SST.

HINT:

Clearing the DTCs cannot be performed by removing the cable from the negative (-) battery terminal or the ECU-IG fuse.

5. END OF CHECK/CLEAR

- (a) Turn the power switch ON (READY).
- (b) Check that the Brake Control warning light, ABS warning light and VSC warning light go off within approximately 3 seconds.

FREEZE FRAME DATA

1. FREEZE FRAME DATA

HINT:

- Whenever a DTC is detected or the ABS operates, the skid control ECU stores the current vehicle (sensor) state as freeze frame data.
- The skid control ECU stores the number of times (maximum: 31) the power switch has been turned from OFF to the ON (IG or READY) position since the last time ABS was activated. However, if the vehicle was stopped or at low speed (4.3 mph (7 km/h) or less), or if a DTC is detected, the skid control ECU will not count the number since then.
- Freeze frame data at the time the ABS operates: The skid control ECU stores and updates data whenever the ABS system operates. When the ECU stores data at the time a DTC is detected, the data stored when the ABS operated is erased.
- Freeze frame data at the time a DTC is detected: When the skid control ECU stores data at the time a DTC is detected, no updates will be performed until the data is cleared.
 - (a) Connect the intelligent tester (with CAN VIM) to the DLC3.
 - (b) Turn the power switch ON (READY).
 - (c) From the display on the tester, select the FREEZE FRAME DATA.

Intelligent Tester Display	Measurement Item	Reference Value
BUZZER	Buzzer	Buzzer ON: ON, OFF: OFF
RESERVOIR SW	Reservoir level warning switch	Reservoir level warning switch ON: ON, OFF: OFF
PKB SW	Parking brake switch	Parking brake switch ON: ON, OFF: OFF
SHIFT POSITION	Shift position	Fail P, N R D (M) 4 3 2 L
VSC/TRC OFF SW	VSC OFF switch	VSC OFF switch ON: ON, OFF: OFF
STOP LIGHT SW	Stop light switch	Stop light switch ON: ON, OFF: OFF
SYSTEM	SYSTEM	ABS VSC (TRC) BA HAB FAIL SAFE PBA PB NO SYS
# IG ON	# IG ON	0 to 31
VEHICLE SPD	Vehicle speed	Speed indicated on speedometer
STEERING ANG	Steering sensor	Left turn: Increase Right turn: Drop (Deceleration)
YAW RATE	Yaw rate sensor	-128 to 127
MAS CYL PRESS	Master cylinder pressure	0 to 5 V

Intelligent Tester Display	Measurement Item	Reference Value
PEDAL STROKE	Stroke sensor	0 to 5.1 V
THROTTLE	Throttle position sensor	Release accelerator pedal: Approx. 0 deg. Depress accelerator pedal: Approx. 125 deg.
MAS PRESS GRADE	Master pressure sensor grade	30 to 225 Mpa/s
G (RIGHT & LEFT)	Right and left G	-1869 to 1869
G (BACK & FORTH)	Back and forth G	-1869 to 1869
SPD GRADE	Vehicle speed grade	-1869 to 1869
FR W/C SENS	FR wheel cylinder pressure sensor	0 to 5 V
FL W/C SENS	FL wheel cylinder pressure sensor	0 to 5 V
RR W/C SENS	RR wheel cylinder pressure sensor	0 to 5 V
RL W/C SENS	RL wheel cylinder pressure sensor	0 to 5 V
ACCUM PRESS	Accumulator pressure sensor	0 to 5 V
MAS CYL PRESS 2	Master cylinder pressure sensor 2	0 to 5 V
PEDAL STROKE 2	Stroke sensor 2	0 to 5 V
MTT	MTT	0 to 5 V
IG1 VOLTAGE	Voltage value of IG1	0 to 20 V
IG2 VOLTAGE	Voltage value of IG2	0 to 20 V
BS1	BS1	0 to 20 V
BS2	BS2	0 to 20 V
VM1	VM1	0 to 20 V
VM2	VM2	0 to 20 V
+B1	+B1	0 to 5 V
+B2	+B2	0 to 5 V
FR TARGET OIL	Target oil pressure (FR)	0 to 20 V
FL TARGET OIL	Target oil pressure (FL)	0 to 20 V
RR TARGET OIL	Target oil pressure (RR)	0 to 20 V
RL TARGET OIL	Target oil pressure (RL)	0 to 20 V
SLAFR CUR	Current of SLAFR solenoid	0 to 1.5 A
SLAFL CUR	Current of SLAFL solenoid	0 to 1.5 A
SLARR CUR	Current of SLARR solenoid	0 to 1.5 A
SLARL CUR	Current of SLARL solenoid	0 to 1.5 A
SLRFR CUR	Current of SLRFR solenoid	0 to 1.5 A
SLRFL CUR	Current of SLRFL solenoid	0 to 1.5 A
SLRRR CUR	Current of SLRRR solenoid	0 to 1.5 A
SLRRL CUR	Current of SLRRL solenoid	0 to 1.5 A
WHEEL SPD FR	Front right wheel speed	0 to 255 km/h
WHEEL SPD FL	Front left wheel speed	0 to 255 km/h
WHEEL SPD RR	Rear right wheel speed	0 to 255 km/h
WHEEL SPD RL	Rear left wheel speed	0 to 255 km/h
CAPA MODE	Capacitor mode	ON: ON, OFF: OFF
SCSS	SCSS	ON: ON, OFF: OFF
SMC2	SMC2	ON: ON, OFF: OFF
SMC1	SMC1	ON: ON, OFF: OFF
MOTOR RELAY 2	Motor relay 2	ON: ON, OFF: OFF
MOTOR RELAY 1	Motor relay 1	ON: ON, OFF: OFF
MAIN RELAY 2	Main relay 2 for ECB	ON: ON, OFF: OFF
MAIN RELAY 1	Main relay 1 for ECB	ON: ON, OFF: OFF
DETAILED CODE	Detailed code for freeze DTC	0 to 65535

FAIL-SAFE CHART

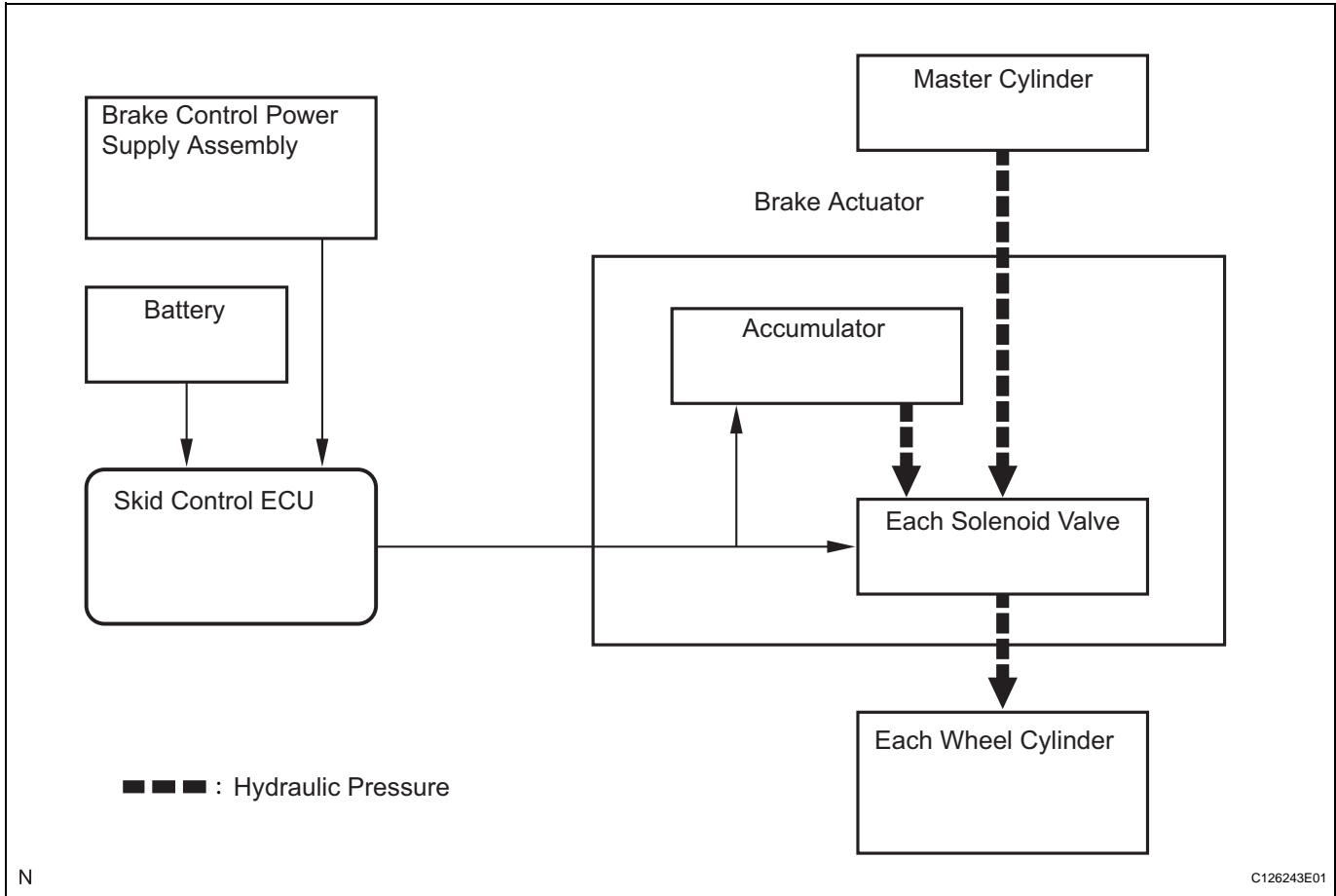

1. FAIL-SAFE FUNCTION

- (a) If a malfunction occurs in the skid control ECU, sensor signal, or actuator, the normally operating parts will maintain brake control.
- (b) If the brake control is stopped under such conditions as when trouble occurs with a hydraulic pressure source, the pressure generated in the master cylinder by the driver is applied to the wheel cylinder to ensure braking force.
- (c) A power back-up unit is built in as an additional power source to supply stable power to the system.
- (d) If the regenerative brake alone does not operate under such conditions as a communication error with the HV ECU, control is switched so that all braking force is generated with the hydraulic pressure brake.

BC

Trouble Area	Generated Braking Force
Skid control ECU	Normally operating parts will control brake and generate braking force
Hydraulic pressure controlling parts	Normally operating parts will control brake and generate braking force
Hydraulic pressure source	Braking force generated by the driver

DATA LIST / ACTIVE TEST

1. READ DATA LIST

HINT:

Using the intelligent tester's DATA LIST allows switch, sensor, actuator and other item values to be read without removing any parts. Reading the DATA LIST early in troubleshooting in one way to save time.

(a) Connect the intelligent tester (with CAN VIM) to the DLC3.

(b) Turn the power switch ON (IG).

(c) Turn the intelligent tester on.

(d) Read the DATA LIST according to the display on the tester.

Skid control ECU

Item	Measurement Item / Range (Display)	Normal Condition	Diagnostic Note
YAW RATE	Yaw rate sensor / Min.: -128 deg/s, Max.: 128 deg/s	Min.: -128 deg/s Max.: 128 deg/s	-
YAW ZERO VALUE	Memorized zero value / Min.: -128 deg/s, Max.: 128 deg/s	Min.: -128 deg/s Max.: 128 deg/s	-
STEERING ANG	Steering sensor / Min.: -1152 deg, Max.: 1150.875 deg	Left turn: Increase Right turn: Decrease	-
1 SYS BRAKE	1 system brake / OPERATE or BEFORE	OPERATE: During operation	-
REGEN CO OPRT	Regenerate co operation / OPERATE or BEFORE	OPERATE: During operation	-
AIR BLD SUPPORT	Air bleed availability / SUPPORT or NOT SUP	SUPPORT: During support	-
PKB SW	Parking brake switch / ON or OFF	ON: Parking brake applied OFF: Parking brake released	-
STOP LIGHT SW	Stop light switch / ON or OFF	ON: Brake pedal depressed OFF: Brake pedal released	-
TEST MODE	Test mode / NORMAL or TEST	NORMAL: Normal mode TEST: During test mode	-
RESERVOIR SW	Reservoir level warning switch / ON or OFF	ON: Reservoir level Normal OFF: Reservoir level Low	-
WHEEL SPD FR	Wheel speed sensor (FR) reading / Min.: 0 km/h (0 mph), Max.: 326 km/h (202 mph)	Actual wheel speed	Similar speed as indicated on speedometer
WHEEL SPD FL	Wheel speed sensor (FL) reading / Min.: 0 km/h (0 mph), Max.: 326 km/h (202 mph)	Actual wheel speed	Similar speed as indicated on speedometer
WHEEL SPD RR	Wheel speed sensor (RR) reading / Min.: 0 km/h (0 mph), Max.: 326 km/h (202 mph)	Actual wheel speed	Similar speed as indicated on speedometer
WHEEL SPD RL	Wheel speed sensor (RL) reading / Min.: 0 km/h (0 mph), Max.: 326 km/h (202 mph)	Actual wheel speed	Similar speed as indicated on speedometer
VEHICLE SPD	Maximum wheel speed sensor reading / Min.: 0 km/h (0 mph), Max.: 326 km/h (202 mph)	Actual vehicle speed	Speed indicated on speedometer
IG VOLTAGE	ECU power supply voltage / TOO HIGH, TOO LOW or NORMAL	TOO HIGH: 9.5 V or over NORMAL: 9.5 V TOO LOW: Below 9.5 V	-
DECELERAT SENS	Deceleration sensor 1 reading / Min.: -1.869 G, Max.: 1.869 G	Approximately 0 +/-0.13 G when vehicle is still	Reading changes when vehicle is bounced
DECELERAT SENS2	Deceleration sensor 2 reading / Min.: -1.869 G, Max.: 1.869 G	Approximately 0 +/-0.13 G when vehicle is still	Reading changes when vehicle is bounced

Item	Measurement Item / Range (Display)	Normal Condition	Diagnostic Note
MAS CYL PRS 1	Master cylinder pressure sensor 1 reading / Min.: 0 V, Max.: 5 V	When brake pedal is released: 0.3 to 0.9 V	Reading increases when brake pedal is depressed
MAS CYL PRS 2	Master cylinder pressure sensor 2 reading / Min.: 0 V, Max.: 5 V	When brake pedal is released: 0.3 to 0.9 V	Reading increases when brake pedal is depressed
SLAFR CUR	Current of SLAFR solenoid / Min.: 0 A, Max.: 3 A	When brake pedal is released: 0 A	-
SLAFL CUR	Current of SLAFL solenoid / Min.: 0 A, Max.: 3 A	When brake pedal is released: 0 A	-
SLARR CUR	Current of SLARR solenoid / Min.: 0 A, Max.: 3 A	When brake pedal is released: 0 A	-
SLARL CUR	Current of SLARL solenoid / Min.: 0 A, Max.: 3 A	When brake pedal is released: 0 A	-
SLRFR CUR	Current of SLRFR solenoid / Min.: 0 A, Max.: 3 A	When brake pedal is released: 0 A	-
SLRFL CUR	Current of SLRFL solenoid / min.: 0 A, max.: 3 A	When brake pedal is released: 0 A	-
SLRRR CUR	Current of SLRRR solenoid/ Min.: 0 A, Max.: 3 A	When brake pedal is released: 0 A	-
SLRRL CUR	Current of SLRRL solenoid / Min.: 0 A, Max.: 3 A	When brake pedal is released: 0 A	-
PEDAL STROKE	Stroke sensor / Min.: 0 V, Max.: 5 V	When brake pedal is released: 0.7 to 1.3 V	-
PEDAL STROKE 2	Stroke sensor 2 / Min.: 0 V, Max.: 5 V	When brake pedal is released: 3.7 to 4.3 V	-
MC 2	MC2 / ON or OFF	ON: Operate	-
MC 1	MC1 / ON or OFF	ON: Operate	-
SSC	SSC / ON or OFF	ON: Operate	-
PATTERN	A pattern drive is under enforcement / ON or OFF	ON: Operate	-
MAIN RELAY 2	Main relay 2 for ECB / ON or OFF	ON: Operate	-
MAIN RELAY 1	Main relay 1 for ECB / ON or OFF	ON: Operate	-
ACC PRESS SENS 1	Accumulator pressure sensor 1 / Min.: 0 V, Max.: 5 V	Specified value: 3.2 to 4.0 V	-
FR PRESS SENS	Front right pressure sensor / Min.: 0 V, Max.: 5 V	When brake pedal is released: 0.3 to 0.9 V	-
FL PRESS SENS	Front left pressure sensor / Min. 0 V, Max.: 5 V	When brake pedal is released: 0.3 to 0.9 V	-
RR PRESS SENS	Rear right pressure sensor / Min.: 0 V, Max.: 5 V	When brake pedal is released: 0.3 to 0.9 V	-
RL PRESS SENS	Rear left pressure sensor / Min. 0 V, Max.: 5 V	When brake pedal is released: 0.3 to 0.9 V	-
MOTOR RELAY 2	Motor relay 2 / ON or OFF	ON: Motor relay ON	-
MOTOR RELAY 1	Motor relay 1 / ON or OFF	ON: Motor relay ON	-
VSC	Existence of VSC / WITH or WITHOUT	WITH: WITH Enhanced VSC System	-
2 FRAMES	There is two or more frame for freeze frame data / YES or NO	YES: There are two or more freeze frame data	-
REGEN TORQ FR	Regenerative request torque (FR) / Min.: 0 N*m, Max.: 4080 N*m	ECB is not operate: 0 N*m	-
REGEN TORQ FL	Regenerative request torque (FL) / Min.: 0 N*m, Max.: 4080 N*m	ECB is not operate: 0 N*m	-
REGEN TORQ RR	Regenerative request torque (RR) / Min.: 0 N*m, Max.: 4080 N*m	-	-
REGEN TORQ RL	Regenerative request torque (RL) / Min.: 0 N*m, Max.: 4080 N*m	-	-

Item	Measurement Item / Range (Display)	Normal Condition	Diagnostic Note
SPD SEN FR	FR speed sensor open detection / OPN-DET or NORMAL	NORMAL: Normal condition	-
SPD SEN FL	FL speed sensor open detection / OPN-DET or NORMAL	NORMAL: Normal condition	-
SPD SEN RR	RR speed sensor open detection / OPN-DET or NORMAL	NORMAL: Normal condition	-
SPD SEN RL	RL speed sensor open detection / OPN-DET or NORMAL	NORMAL: Normal condition	-
YAW RATE SEN	Yaw rate sensor open detection / OPN-DET or NORMAL	NORMAL: Normal condition	-
DECELE SEN	Deceleration sensor open detection / OPN-DET or NORMAL	NORMAL: Normal condition	-
STEERING SEN	Steering sensor open detection / OPN-DET or NORMAL	NORMAL: Normal condition	-
M/C SEN 1	Master cylinder pressure sensor 1 open detection / OPN-DET or NORMAL	NORMAL: Normal condition	-
M/C SEN 2	Master cylinder pressure sensor 2 open detection / OPN-DET or NORMAL	NORMAL: Normal condition	-
STROKE SEN 1	Stroke sensor open detection / OPN-DET or NORMAL	NORMAL: Normal condition	-
FR W/C SEN	FR wheel cylinder pressure sensor open detection / OPN-DET or NORMAL	NORMAL: Normal condition	-
FL W/C SEN	FL wheel cylinder pressure sensor open detection / OPN-DET or NORMAL	NORMAL: Normal condition	-
RR W/C SEN	RR wheel cylinder pressure sensor open detection / OPN-DET or NORMAL	NORMAL: Normal condition	-
RL W/C SEN	RL wheel cylinder pressure sensor open detection / OPN-DET or NORMAL	NORMAL: Normal condition	-
HV COM	HV communication open detection / OPN-DET or NORMAL	NORMAL: Normal condition	-
ACC SEN	Accumulator pressure sensor open detection / ERROR or NORMAL	ERROR: Momentary interruption NORMAL: Normal condition	-
BUZZER	Buzzer / ON or OFF	ON: Buzzer ON OFF: Buzzer OFF	-
RESERVOIR SW	Reservoir level warning switch / ON or OFF	ON: Reservoir level normal OFF: Reservoir level low	-
SHIFT POSITION	Shift position / FAIL / L / 2 / 3 / 4 / D (M) / R / P.N	-	-
VSC/TRC OFF SW	TRAC control switch / ON or OFF	ON: TRAC control switch ON	-
STOP LIGHT SW	Stop light switch / ON or OFF	ON: Operate	-
SYSTEM	SYSTEM / ABS / VSC (TRAC) / BA / HAB / FAIL SAFE / PB / NOSYS	-	-
# IG ON	# IG ON / 0 to 31	0	-
STEERING ANG	Steering sensor / Min.: -1152 deg, Max.: 1150.875 deg	Left turn: Increase Right turn: Decrease	-
YAW RATE	Yaw rate sensor/ Min.: -128 deg/s, Max.: 128 deg/s	Min.: -128 deg/s Max.: 128 deg/s	-

Item	Measurement Item / Range (Display)	Normal Condition	Diagnostic Note
MAS CYL PRESS	Master cylinder pressure / Min.: 0 V, Max.: 5 V	When brake pedal is released: 0.3 to 0.9 V	Reading increases when brake pedal is depressed
PEDAL STROKE	Stroke sensor / Min.: 0 V, Max.: 5 V	When brake pedal is released (SKS1): 0.7 to 1.5 V When brake pedal is released (SKS2): 3.7 to 4.3 V	-
THROTTLE	Throttle position sensor / Min.: 0 deg, Max.: 125 deg	Release accelerator pedal: Approx. 0 deg. Depress accelerator pedal: Approx. 90 deg.	-
MAS PRESS GRADE	Master pressure sensor grade / Min.: -30Mpa/s, Max.: 225 Mpa/s	When brake pedal is released: 0 MPa	-
G (RIGHT & LEFT)	Right and left G / Min.: -1.869 G, Max.: 1.869 G	Approximately 0 +/-0.13 G when vehicle is still	-
G (BACK & FORTH)	Back and forth G / Min.: -1.869 G, Max.: 1.869 G	Approximately 0 +/-0.13 G when vehicle is still	-
SPD GRADE	Vehicle speed grade / Min.: -1.869 G, Max.: 1.869 G	Approximately 0 +/-0.13 G when vehicle is still	-
# CODES	Number of DTC recorded / Min.: 0, Max.: 255	Min.: 0, max.: 39	-

2. PERFORM ACTIVE TEST

HINT:

Performing the intelligent tester's ACTIVE TEST allows relay, VSV, actuator and other items to be operated without removing any parts. Performing the ACTIVE TEST early in troubleshooting is one way to save time. The DATA LIST can be displayed during the ACTIVE TEST.

- (a) Connect the intelligent tester (with CAN VIM) to the DLC3.
- (b) Turn the power switch ON (READY).
- (c) Perform the ACTIVE TEST according to the display on the tester.

Skid control ECU

Item	Test Details	Diagnostic Note
ABS WARN LIGHT	Turns ABS warning light ON / OFF	Observe combination meter
VSC WARN LIGHT	Turns VSC warning light ON / OFF	Observe combination meter
SLIP INDI LIGHT	Turns SLIP indicator light ON / OFF	Observe combination meter
BRAKE WARN LIGHT	Turns BRAKE warning light ON / OFF	Observe combination meter
VSC/BR WARN BUZ	Turns VSC / BRAKE warning buzzer ON / OFF	Buzzer can be heard
ECB INDI LIGHT	Turns Brake Control warning light ON / OFF	Observe combination meter
MAIN RELAY 1	Turns MAIN RELAY 1 ON / OFF	Operation of solenoid (clicking sound) can be heard
MAIN RELAY 2	Turns MAIN RELAY 2 ON / OFF	Operation of solenoid (clicking sound) can be heard
MC 1	Turns Master cut valve 1 activation ON / OFF	Operation of solenoid (clicking sound) can be heard
MC 2	Turns Master cut valve 2 activation ON / OFF	Operation of solenoid (clicking sound) can be heard
MOTOR RELAY 1	Turns MOTOR RELAY 1 ON / OFF	Operation of solenoid (clicking sound) can be heard
MOTOR RELAY 2	Turns MOTOR RELAY 2 ON / OFF	Operation of solenoid (clicking sound) can be heard

Item	Test Details	Diagnostic Note
ECB INVALID	Turns ECB invalid ON / OFF	Operation of solenoid (clicking sound) can be heard
ACC PATTERN	Actuator air bleeding pattern activation ON / OFF	Operation of solenoid (clicking sound) can be heard
SCC PATTERN	Stroke simulator cut valve pattern activation ON / OFF	Operation of solenoid (clicking sound) can be heard
POWER SUPPLY 1	Power supply air bleeding pattern activation 1 ON / OFF	Operation of solenoid (clicking sound) can be heard
POWER SUPPLY 2	Power supply air bleeding pattern activation 2 ON / OFF	Operation of solenoid (clicking sound) can be heard
RL AIR BLEEDING	RL wheel air bleeding pattern activation ON / OFF	Operation of solenoid (clicking sound) can be heard
RR AIR BLEEDING	RR wheel air bleeding pattern activation ON / OFF	Operation of solenoid (clicking sound) can be heard
ZERO DOWN	Accumulator zero down activation ON / OFF	Operation of solenoid (clicking sound) can be heard
PUMP PATTERN	Pump check pattern activation ON / OFF	Operation of solenoid (clicking sound) can be heard
DRAIN PATTERN	Drain system air bleeding pattern activation ON / OFF	Operation of solenoid (clicking sound) can be heard

DIAGNOSTIC TROUBLE CODE CHART

HINT:

If a malfunction code is displayed during the DTC check, check the circuit indicated by the DTC. For details of each code, refer to the respective "DTC No." in the DTC chart.

DTC chart of ABS

DTC No.	Detection Item	INF Code	Trouble Area	See page
C0200/31	Front Speed Sensor RH Circuit	251 252 253 254 256 257 258 259 260 261 262	- Right front speed sensor - Speed sensor circuit - Sensor rotor - Sensor installation	BC-54
C0205/32	Front Speed Sensor LH Circuit	264 265 266 267 268 269 270 271 272 273 274 275	- Left front speed sensor - Speed sensor circuit - Sensor rotor - Sensor installation	BC-54
C0210/33	Rear Speed Sensor RH Circuit	277 278 279 280 281 282 283 284 285 286 287 288	- Right rear speed sensor - Speed sensor circuit - Sensor rotor - Sensor installation	BC-61
C0215/34	Rear Speed Sensor LH Circuit	290 291 292 293 294 295 296 297 298 299 300 301	- Left rear speed sensor - Speed sensor circuit - Sensor rotor - Sensor installation	BC-61
C1235/35	Foreign Object is Attached on Tip of Front Speed Sensor RH	302	- Right front speed sensor - Speed sensor circuit - Sensor installation	BC-79
C1236/36	Foreign Object is Attached on Tip of Front Speed Sensor LH	303	- Left front speed sensor - Speed sensor circuit - Sensor installation	BC-79
C1238/38	Foreign Object is Attached on Tip of Rear Speed Sensor RH	304	- Right rear speed sensor - Speed sensor circuit - Sensor installation	BC-79

DTC No.	Detection Item	INF Code	Trouble Area	See page
C1239/39	Foreign Object is Attached on Tip of Rear Speed Sensor LH	305	- Left rear speed sensor - Speed sensor circuit - Sensor installation	BC-79
C1243/43	Acceleration Sensor Stuck Malfunction	317	- Yaw rate (deceleration) sensor - Skid control ECU	BC-70
C1244/44	Open or Short in Acceleration Sensor Circuit	314	- Yaw rate (deceleration) sensor - Yaw rate (deceleration) sensor installation - Zero point calibration not done - Skid control ECU	BC-70
C1245/45	Acceleration Sensor Output Malfunction	313	- Yaw rate (deceleration) sensor - Zero point calibration not done - Skid control ECU	BC-70
C1381/97	Yaw Rate and / or Acceleration Sensor Power Supply Voltage Malfunction	315	- Yaw rate (deceleration) sensor circuit - Harness and connector - Skid control ECU	BC-70

1. Drive the vehicle at the vehicle speed of (50 km/h) 31 mph and keep depressing the brake pedal strongly for approximately 3 seconds.
2. Repeat the above operation 3 times or more and check that the ABS warning light goes off.
3. Clear the DTC.

HINT:

In some cases, the intelligent tester cannot be used when ABS warning light remains on.

DTC chart of Enhanced VSC

DTC No.	Detection Item	INF Code	Trouble Area	See page
C1210/36	Zero Point Calibration of Yaw Rate Sensor Undone	336	- Zero point calibration undone (Perform zero point calibration and check DTC. If DTC is not output again, the sensor is normal.)	BC-70
C1231/31	Steering Angle Sensor Circuit Malfunction	341 342 343 344 345 346 347 348 349	- Steering angle sensor - Skid control ECU	BC-75
C1232/32	Stuck in Acceleration Sensor	311 312	- Yaw rate (deceleration) sensor - Skid control ECU	BC-70
C1234/34	Yaw Rate Sensor Malfunction	331 332 333 334 335 337	- Yaw rate (deceleration) sensor	BC-70
C1310/51	Malfunction in HV system	156	- Hybrid control system (Enhanced VSC, TRAC system)	BC-119

DTC No.	Detection Item	INF Code	Trouble Area	See page
C1336/39	Zero Point Calibration of Acceleration Sensor Undone	318	- Zero point calibration undone (Perform zero point calibration and check DTC. If DTC is not output again, the sensor is normal.)	BC-70

DTC chart of ECB

DTC No.	Detection Item	INF Code	Trouble Area	See page
C1202/68	Master Reservoir Level Malfunction	511 512	- Brake fluid level - Brake fluid level warning switch - Harness and connector - Skid control ECU	BC-66
C1203/95	ECM Communication Circuit Malfunction	-	- Skid control ECU	BC-69
C1241/41	Low Battery Positive Voltage or Abnormally High Battery Positive Voltage	81 82 83 84	- ABS NO. 1 relay - ABS NO. 2 relay - Harness and connector - Skid control power supply circuit - Brake control power supply assembly - Hybrid control system	BC-84
C1242/42	Open in IG1 / IG2 Power Source Circuit	87 88	- ABS NO. 1 relay - ABS NO. 2 relay - Harness and connector - Skid control power supply circuit - Brake control power supply assembly - Hybrid control system	BC-84
C1246/46	Master Cylinder Pressure Sensor Malfunction	191 192 194 195 197 198 199 200 201 202 205	- Brake actuator assembly - Skid control ECU - Harness and connector	BC-92
C1247/47	Stroke Sensor Malfunction	171 172 173 174 175 176 177 179 180	- Brake pedal stroke sensor - Skid control ECU - Harness and connector	BC-99
C1249/49	Open in Stop Light Switch Circuit	520	- Stop light switch - Stop light switch control - Stop light bulb	BC-104
C1252/52	Brake Booster Pump Motor on Time Abnormally Long	130	- Brake actuator assembly	BC-109
C1253/53	Hydro Booster Pump Motor Relay Malfunction	132 133 134 136 137 138 140	- ABS MTR relay - ABS MTR 2 relay - Harness and connector - Brake actuator assembly	BC-109

DTC No.	Detection Item	INF Code	Trouble Area	See page
C1256/57	Accumulator Low Pressure	141 143	- Brake actuator assembly (accumulator pressure, accumulator pressure sensor, pump motor)	BC-117
C1259/58	HV System Regenerative Malfunction	150	- Hybrid control system	BC-119
C1300	Skid Control ECU Malfunction	-	- Skid control ECU	BC-121
C1311/11	Open in Main Relay 1 Circuit	1	- ABS NO. 1 relay - Skid control ECU - Harness and connector	BC-122
C1312/12	Short in Main Relay 1 Circuit	3	- ABS NO. 1 relay - Skid control ECU - Harness and connector	BC-122
C1313/13	Open in Main Relay 2 Circuit	4	- ABS NO. 2 relay - Skid control ECU - Harness and connector	BC-122
C1314/14	Short in Main Relay 2 Circuit	6	- ABS NO. 2 relay - Skid control ECU - Harness and connector	BC-122
C1315/31	SMC1 Changeover Solenoid Malfunction	61 62 63 64	- Brake actuator assembly (SMC1) - Skid control ECU - Harness and connector	BC-129
C1316/32	SMC2 Changeover Solenoid Malfunction	66 67 68 69	- Brake actuator assembly (SMC2) - Skid control ECU - Harness and connector	BC-129
C1319/35	SCSS Changeover Solenoid Malfunction	71 72 73 74	- Stroke simulator - Skid control ECU - Harness and connector	BC-137
C1341/62	Front Hydraulic System RH Malfunction	551 552 553 554 555	- Fluid leakage - Brake actuator assembly - Disc rotor	BC-141
C1342/63	Front Hydraulic System LH Malfunction	561 562 563 564 565	- Fluid leakage - Brake actuator assembly - Disc rotor	BC-141
C1343/64	Rear Hydraulic System RH Malfunction	571 572 573 574 575	- Fluid leakage - Brake actuator assembly - Disc rotor	BC-141
C1344/65	Rear Hydraulic System LH Malfunction	581 582 583 584 585	- Fluid leakage - Brake actuator assembly - Disc rotor	BC-141
C1345/66	Linear Solenoid Valve Offset Learning Undone	501 502 503 504	- Initialization of linear solenoid valve and calibration undone	BC-149
C1352/21	Front Increasing Pressure Solenoid RH Malfunction	11 12 13 14	- Brake actuator assembly - Skid control ECU - Harness and connector	BC-129

DTC No.	Detection Item	INF Code	Trouble Area	See page
C1353/23	Front Increasing Pressure Solenoid LH Malfunction	21 22 23 24	- Brake actuator assembly - Skid control ECU - Harness and connector	BC-129
C1354/25	Rear Increasing Pressure Solenoid RH Malfunction	31 32 33 34	- Brake actuator assembly - Skid control ECU - Harness and connector	BC-129
C1355/27	Rear Increasing Pressure Solenoid LH Malfunction	41 42 43 44	- Brake actuator assembly - Skid control ECU - Harness and connector	BC-129
C1356/22	Front Decreasing Pressure Solenoid RH Malfunction	16 17 18 19	- Brake actuator assembly - Skid control ECU - Harness and connector	BC-129
C1357/24	Front Decreasing Pressure Solenoid LH Malfunction	26 27 28 29	- Brake actuator assembly - Skid control ECU - Harness and connector	BC-129
C1358/26	Rear Decreasing Pressure Solenoid RH Malfunction	36 37 38 39	- Brake actuator assembly - Skid control ECU - Harness and connector	BC-129
C1359/28	Rear Decreasing Pressure Solenoid LH Malfunction	46 47 48 49	- Brake actuator assembly - Skid control ECU - Harness and connector	BC-129
C1364/61	Wheel Cylinder Pressure Sensor Malfunction	221 222 224 225 226 227 228 230 231 232 233 234 236 237 238 239 240 242 243 244	- Brake actuator assembly - Skid control ECU - Harness and connector	BC-92
C1365/54	Accumulator Pressure Sensor Malfunction	211 212 214 215 216	- Brake actuator assembly (accumulator pressure sensor) - Skid control ECU	BC-150
C1368/67	Linear Solenoid Valve Offset Malfunction	505	- Initialization of linear solenoid valve and calibration undone - Skid control ECU	BC-149

DTC No.	Detection Item	INF Code	Trouble Area	See page
C1377/43	Capacitor Malfunction	101 102 103 105 106 108 109 110 113	- Brake control power supply - Harness and connector - ABS MAIN1 fuse - ABS MAIN2 fuse - ABS MAIN3 fuse - Apply high voltage	BC-154
C1378/44	Capacitor Communication Malfunction	112	- Harness and connector - Skid control ECU	BC-160
C1391/69	Accumulator Leak Malfunction	591	- Fluid leakage - Brake actuator assembly	BC-164
C1392/48	Stroke Sensor Zero Point Calibration Undone	-	- Brake pedal stroke sensor zero point calibration undone (initialization of linear solenoid valve and calibration undone) - Skid control ECU	BC-99

DTC of test mode

DTC No.	Detection Item	INF Code	Trouble Area	See page
C0371/71	Yaw Rate Sensor (Test Mode DTC)		Yaw rate sensor (Deceleration sensor)	BC-70
C1271/71	Low Output Signal of Front Speed Sensor RH (Test Mode DTC)		- Right front speed sensor - Speed sensor circuit - Sensor installation - Sensor rotor	BC-54
C1272/72	Low Output Signal of Front Speed Sensor LH (Test Mode DTC)		- Left front speed sensor - Speed sensor circuit - Sensor installation - Sensor rotor	BC-54
C1273/73	Low Output Signal of Rear Speed Sensor RH (Test Mode DTC)		- Right rear speed sensor - Speed sensor circuit - Sensor installation - Sensor rotor	BC-61
C1274/74	Low Output Signal of Rear Speed Sensor LH (Test Mode DTC)		- Left rear speed sensor - Speed sensor circuit - Sensor installation - Sensor rotor	BC-61
C1275/75	Abnormal Change in Output Signal of Front Speed Sensor RH (Test Mode DTC)		- Right front speed sensor - Speed sensor circuit - Sensor installation	BC-79
C1276/76	Abnormal Change in Output Signal of Front Speed Sensor LH (Test Mode DTC)		- Left front speed sensor - Speed sensor circuit - Sensor installation	BC-79
C1277/77	Abnormal Change in Output Signal of Rear Speed Sensor RH (Test Mode DTC)		- Right rear speed sensor - Speed sensor circuit - Sensor installation	BC-79
C1278/78	Abnormal Change in Output Signal of Rear Speed Sensor LH (Test Mode DTC)		- Left rear speed sensor - Speed sensor circuit - Sensor installation	BC-79
C1279/79	Acceleration Sensor Output Voltage Malfunction (Test Mode DTC)		- Yaw rate (deceleration) sensor - Yaw rate (deceleration) sensor circuit	BC-70

DTC No.	Detection Item	INF Code	Trouble Area	See page
C1281/81	Master Cylinder Pressure Sensor Output Malfunction (Test Mode DTC)		- Brake actuator assembly - Skid control ECU	BC-92

HINT:

The codes in this table are output only in test mode.

DTC	C0200/31	Front Speed Sensor RH Circuit
DTC	C0205/32	Front Speed Sensor LH Circuit
DTC	C1271/71	Low Output Signal of Front Speed Sensor RH (Test Mode DTC)
DTC	C1272/72	Low Output Signal of Front Speed Sensor LH (Test Mode DTC)

DESCRIPTION

The speed sensor detects wheel speed and sends the appropriate signals to the ECU. These signals are used to control the ABS control system. The front and rear rotors have 48 serrations, respectively. When the rotors rotate, the magnetic field emitted by the permanent magnet in the speed sensor generates an AC voltage. Since the frequency of this AC voltage changes in direct proportion to the speed of the rotor, the frequency is used by the ECU to detect the speed of each wheel.

DTCs C1271/71 and C1272/72 can be deleted when the speed sensor sends a vehicle speed signal or the Test Mode ends. DTCs C1271/71 and C1272/72 are output only in the test mode.

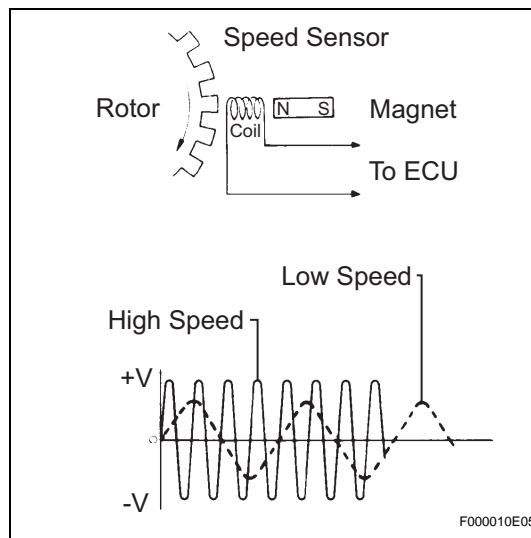

DTC No.	INF Code	DTC Detection Condition	Trouble Area
C0200/31	251 252 253 254 255 256 257 258 259 260 261 262	When one of following conditions is met: <ul style="list-style-type: none"> • Speed of a malfunctioning wheel is 0 km/h (0 mph) for at least 15 sec. when vehicle speed is 10 km/h (6 mph) or more. • Speed of the slowest wheel is less than 1/7th of the 2nd slowest wheel for at least 15 sec. when vehicle speed is 10 km/h (6 mph) or more. • Abnormal high wheel speed pulse is input for at least 15 sec. • Abnormal high wheel speed pulse is input at least 7 times when ECU is on. • Speed sensor pulse signal is instantly cut 7 times or more. • Speed sensor signal line is open for at least 0.5 sec. 	<ul style="list-style-type: none"> • Right front and left front speed sensor • Each speed sensor circuit • Sensor rotor • Sensor installation
C0205/32	264 265 266 267 268 269 270 271 272 273 274 275	When one of following conditions is met: <ul style="list-style-type: none"> • Speed of a malfunctioning wheel is 0 km/h (0 mph) for at least 15 sec. when vehicle speed is 10 km/h (6 mph) or more. • Speed of the slowest wheel is less than 1/7th of the 2nd slowest wheel for at least 15 sec. when vehicle speed is 10 km/h (6 mph) or more. • Abnormal high wheel speed pulse is input for at least 15 sec. • Abnormal high wheel speed pulse is input at least 7 times when ECU is on. • Speed sensor pulse signal is instantly cut 7 times or more. • Speed sensor signal line is open for at least 0.5 sec. 	<ul style="list-style-type: none"> • Right front and left front speed sensor • Each speed sensor circuit • Sensor rotor • Sensor installation
C1271/71 C1272/72	-	Detected only during test mode.	<ul style="list-style-type: none"> • Front speed sensor • Front speed sensor circuit • Sensor rotor • Sensor installation

HINT:

- DTC C0200/31 is for the right front speed sensor.
- DTC C0205/32 is for the left front speed sensor.
- The BRAKE warning light comes on when speed sensor malfunctions are detected in 2 or more wheels.

WIRING DIAGRAM

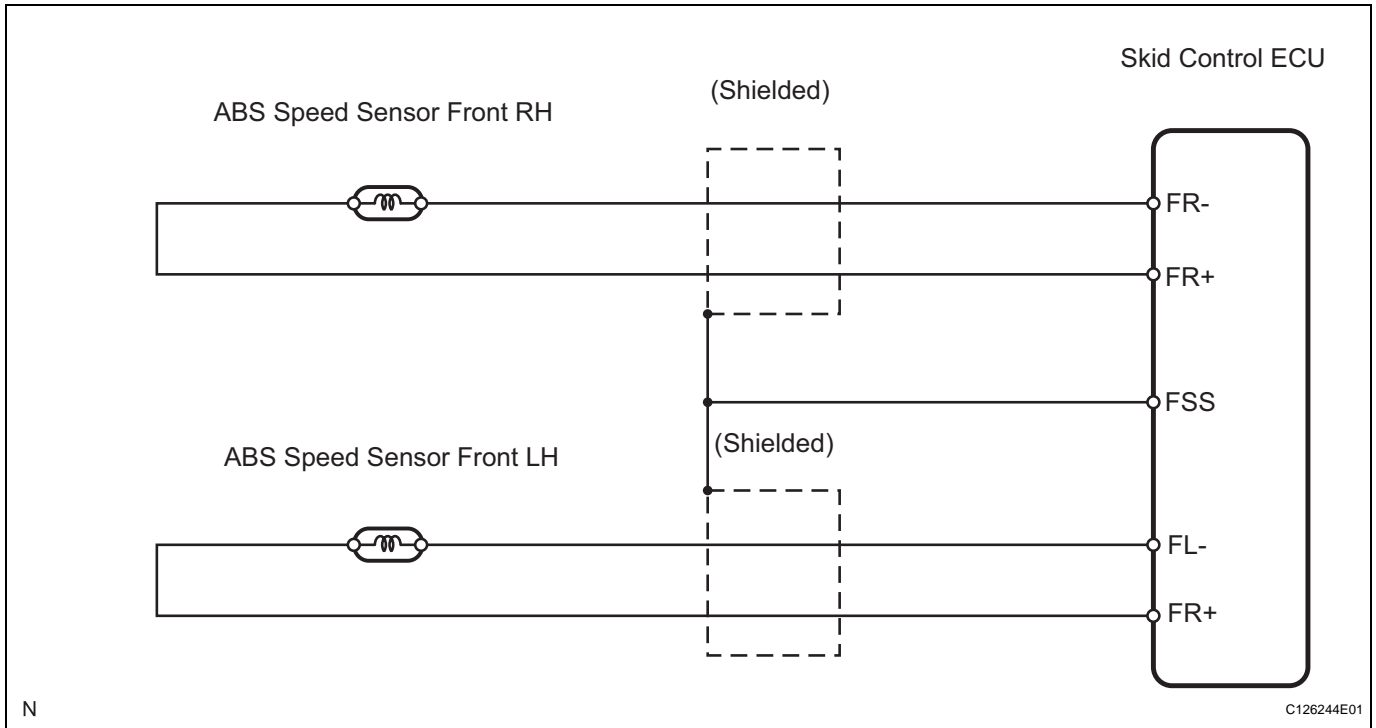

INSPECTION PROCEDURE

NOTICE:

When replacing the skid control ECU, perform initialization of linear solenoid valve and calibration (see page BC-19).

1 CHECK HARNESS AND CONNECTOR (MOMENTARY INTERRUPTION)

- (a) Using the intelligent tester, check for any momentary interruption in the wire harness and connector corresponding to a DTC (see page BC-17).

Skid control ECU

Item	Measurement Item / Range (Display)	Normal Condition	Diagnostic Note
SPD SEN FR	FR speed sensor open detection / OPEN or NORMAL	NORMAL: Normal condition	-
SPD SEN FL	FL speed sensor open detection / OPEN or NORMAL	NORMAL: Normal condition	-

OK:

There are no momentary interruptions.

HINT:

Perform the above inspection before removing the sensor and connector.

BC

NG

Go to step 5

OK

2 READ VALUE OF INTELLIGENT TESTER (FRONT SPEED SENSOR)

- (a) Check the DATA LIST for proper functioning of the front speed sensor.

Skid control ECU

Item	Measurement Item / Range (Display)	Normal Condition	Diagnostic Note
WHEEL SPD FR	Wheel speed sensor (FR) reading / min.: 0 km/h (0 mph), max.: 326 km/h (202 mph)	Actual wheel speed	Similar speed as indicated on speedometer
WHEEL SPD FL	Wheel speed sensor (FL) reading / min.: 0 km/h (0 mph), max.: 326 km/h (202 mph)	Actual wheel speed	Similar speed as indicated on speedometer

OK:

There is almost no difference from the displayed speed value.

HINT:

There is tolerance of +/-10% in the speedometer indication.

NG

Go to step 4

OK

3 CHECK SPEED SENSOR AND SENSOR ROTOR SERRATIONS

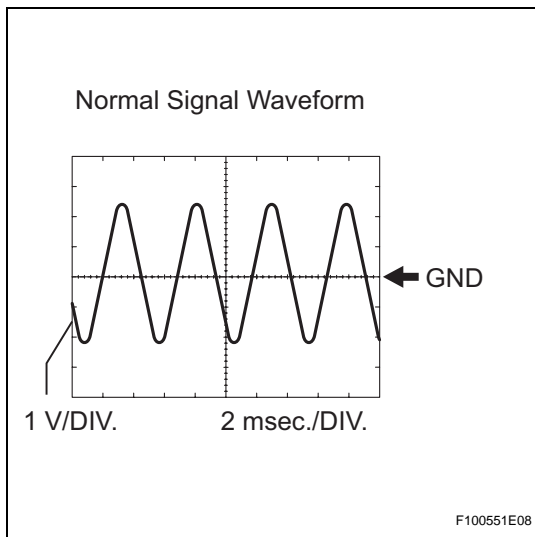

- (a) Connect the oscilloscope to terminal FR+ and FR-, or FL+ and FL- of the skid control ECU.
 (b) Drive the vehicle at approximately 30 km/h (19 mph), and check the signal waveform.

OK:

A waveform as shown should be output.

HINT:

- As the vehicle speed (wheel revolution speed) increases, a cycle of the waveform narrows and the fluctuation in the output voltage becomes greater.
- When noise is identified in the waveform on the oscilloscope, error signals are generated due to the speed sensor rotor's scratches, looseness or foreign matter deposited on it.

NG

Go to step 6

OK

REPLACE SKID CONTROL ECU

4 INSPECT FRONT SPEED SENSOR

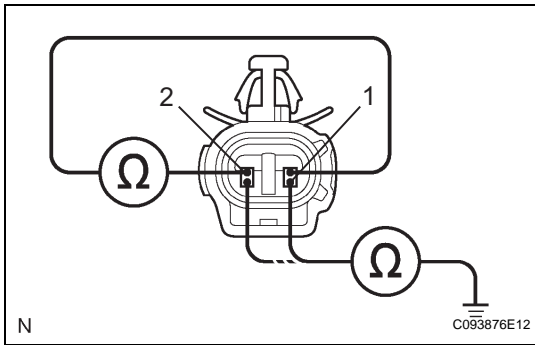

- (a) Disconnect the speed sensor connector.
- (b) Measure the resistance of the sensors.

**Standard resistance:
for LH**

Tester Connection	Specified Condition
2 (FL+) - 1 (FL-)	1.4 to 1.8 kΩ
1 (FL-) - Body ground	10 kΩ or higher
2 (FL+) - Body ground	10 kΩ or higher

for RH

Tester Connection	Specified Condition
2 (FR+) - 1 (FR-)	1.4 to 1.8 kΩ
1 (FR-) - Body ground	10 kΩ or higher
2 (FR+) - Body ground	10 kΩ or higher

NOTICE:

Check the speed sensor signal after replacement (see page [BC-23](#)).

NG → **REPLACE FRONT SPEED SENSOR**

OK

5 CHECK WIRE HARNESS (SKID CONTROL ECU - FRONT SPEED SENSOR)

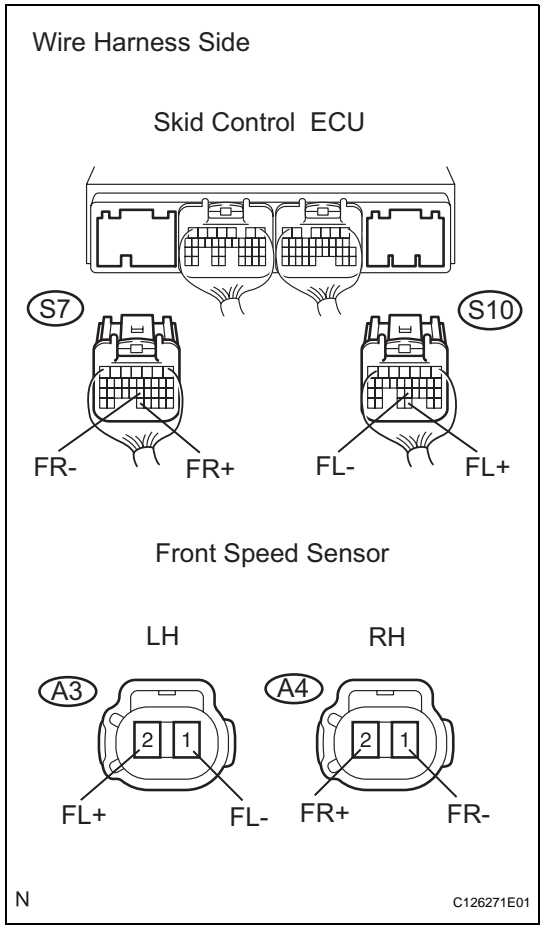

- (a) Disconnect the S7 and S10 ECU connectors.
- (b) Disconnect the A3 and A4 sensor connectors.
- (c) Measure the resistance of the wire harness side connectors.

Standard resistance:
for LH

Tester Connection	Specified Condition
A3-1 (FL-) - S10-22 (FL-)	Below 1 Ω
A3-2 (FL+) - S10-28 (FL+)	Below 1 Ω
A3-2 (FL+) - Body ground	10 kΩ or higher
A3-1 (FL-) - Body ground	10 kΩ or higher

for RH

Tester Connection	Specified Condition
A4-1 (FR-) - S7-22 (FR-)	Below 1 Ω
A4-2 (FR+) - S7-32 (FR+)	Below 1 Ω
A4-2 (FR+) - Body ground	10 kΩ or higher
A4-1 (FR-) - Body ground	10 kΩ or higher

NG **REPAIR OR REPLACE HARNESS AND CONNECTOR**

OK

6 CHECK SPEED SENSOR AND SENSOR ROTOR SERRATIONS

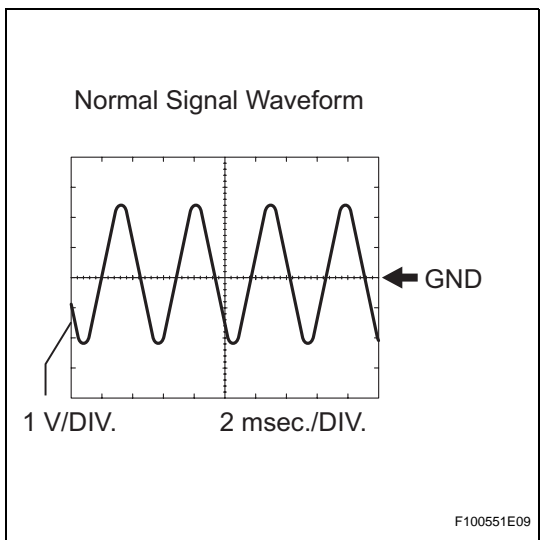

- (a) Connect the oscilloscope to terminals FR+ and FR-, or FL+ and FL- of the skid control ECU.
- (b) Drive the vehicle at approximately 30 km/h (19 mph), and check the signal waveform.

OK:
A waveform as shown should be output.

HINT:

- As the vehicle speed (wheel revolution speed) increases, a cycle of the waveform narrows and the fluctuation in the output voltage becomes greater.
- When noise is identified in the waveform on the oscilloscope, error signals are generated due to the speed sensor rotor's scratches, looseness or foreign matter deposited on it.

NG **Go to step 7**

OK

REPLACE SKID CONTROL ECU

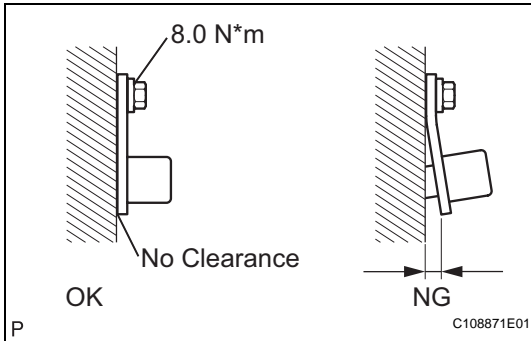
7 INSPECT FRONT SPEED SENSOR INSTALLATION

(a) Check the speed sensor installation.

OK:

The installation bolt is tightened properly and there is no clearance between the sensor and front steering knuckle.

Torque: 8.0 N*m (82 kgf*cm, 71 in.*lbf)**NOTICE:**

Check the speed sensor signal after the replacement (see page [BC-23](#)).

NG

REPLACE FRONT SPEED SENSOR

OK

REPLACE SKID CONTROL ECU

DTC	C0210/33	Rear Speed Sensor RH Circuit
DTC	C0215/34	Rear Speed Sensor LH Circuit
DTC	C1273/73	Low Output Signal of Rear Speed Sensor RH (Test Mode DTC)
DTC	C1274/74	Low Output Signal of Rear Speed Sensor LH (Test Mode DTC)

DESCRIPTION

Refer to DTC C0200/31 and C0205/32 (see page [BC-54](#)).

DTCs C1273/73 and C1274/74 can be deleted when the speed sensor sends a vehicle speed signal or the Test Mode ends. DTCs C1273/73 and C1274/74 are output only in the Test Mode.

DTC No.	INF Code	DTC Detection Condition	Trouble Area
C0210/33	277 278 279 280 281 282 283 284 285 286 287 288	When one of following conditions is met: <ul style="list-style-type: none"> Speed of a malfunctioning wheel is 0 mph (0 km/h) for at least 15 sec. when vehicle speed is 6 mph (10 km/h) or more. Speed of the slowest wheel is less than 1/7th of the 2nd slowest wheel for at least 15 sec. when vehicle speed is 6 mph (10 km/h) or more. Abnormal high wheel speed pulse is input for at least 15 sec. Abnormal high wheel speed pulse is input at least 7 times when ECU is on. Speed sensor pulse signal is instantly cut 7 times or more. Speed sensor signal line is open for at least 0.5 sec. 	<ul style="list-style-type: none"> Right rear and left rear speed sensor Each speed sensor circuit Sensor rotor Sensor installation Skid control ECU
C0215/34	290 291 292 293 294 295 296 297 298 299 300 301	When one of following conditions is met: <ul style="list-style-type: none"> Speed of a malfunctioning wheel is 0 mph (0 km/h) for at least 15 sec. when vehicle speed is 6 mph (10 km/h) or more. Speed of the slowest wheel is less than 1/7th of the 2nd slowest wheel for at least 15 sec. when vehicle speed is 6 mph (10 km/h) or more. Abnormal high wheel speed pulse is input for at least 15 sec. Abnormal high wheel speed pulse is input at least 7 times when ECU is on. Speed sensor pulse signal is instantly cut 7 times or more. Speed sensor signal line is open for at least 0.5 sec. 	<ul style="list-style-type: none"> Right rear and left rear speed sensor Each speed sensor circuit Sensor rotor Sensor installation Skid control ECU

DTC No.	INF Code	DTC Detection Condition	Trouble Area
C1273/73 C1274/74	-	Detected only during test mode	<ul style="list-style-type: none"> • Rear speed sensor • Rear speed sensor circuit • Sensor rotor • Sensor installation

HINT:

- DTC C0210/33 is for the right rear speed sensor.
- DTC C0215/34 is for the left rear speed sensor.
- The BRAKE warning light comes on when speed sensor malfunctions are detected in two or more wheels.

WIRING DIAGRAM

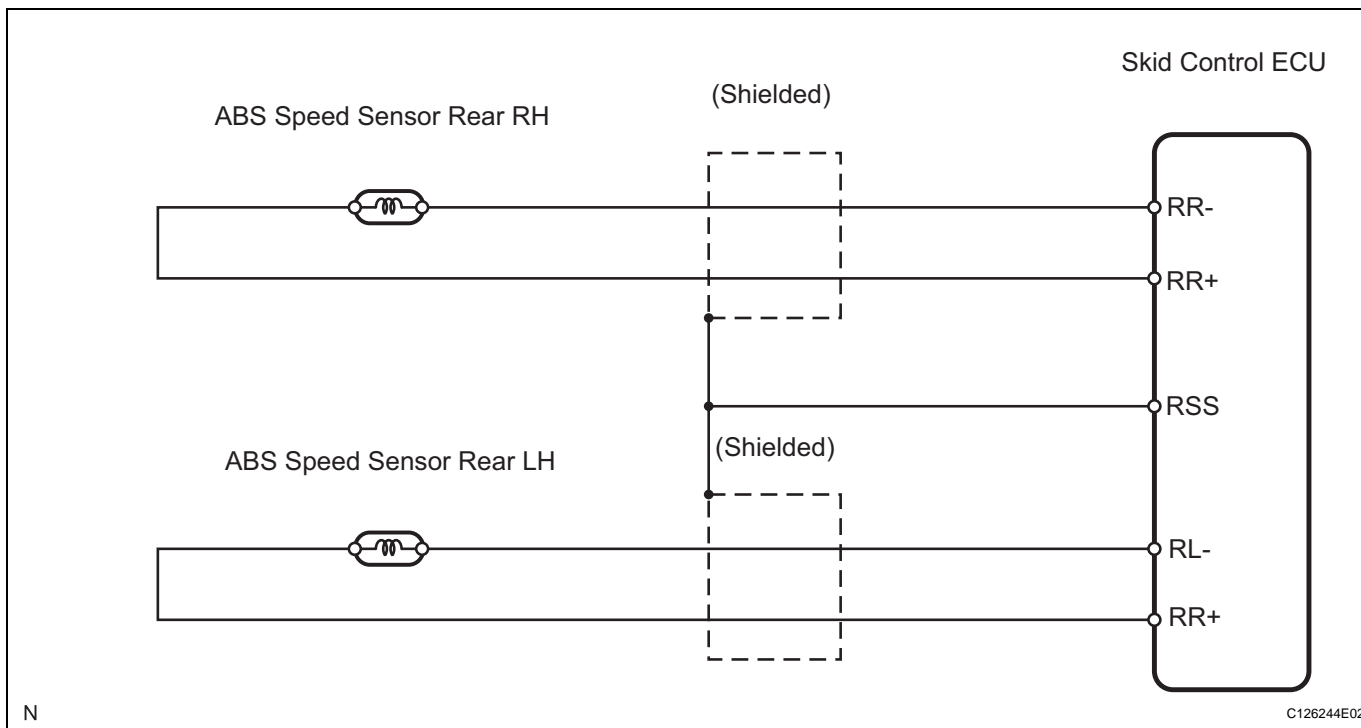

INSPECTION PROCEDURE

NOTICE:

When replacing the skid control ECU, perform initialization of linear solenoid valve and calibration (see page BC-19).

1	CHECK HARNESS AND CONNECTOR (MOMENTARY INTERRUPTION)
----------	---

- (a) Using the intelligent tester, check for any momentary interruption in the wire harness and connector corresponding to a DTC (see page BC-17).

Skid control ECU

Item	Measurement Item / Range (Display)	Normal Condition	Diagnostic Note
SPD SEN RR	RR speed sensor open detection / OPEN or NORMAL	NORMAL: Normal condition	-
SPD SEN RL	RL speed sensor open detection / OPEN or NORMAL	NORMAL: Normal condition	-

OK:

There are no momentary interruption.

HINT:

Perform the above inspection before removing the sensor and connector.

NG

Go to step 5

OK

2 READ VALUE OF INTELLIGENT TESTER (REAR SPEED SENSOR)

- (a) Check the DATA LIST for proper functioning of the rear speed sensor.

Skid control ECU

Item	Measurement Item / Range (Display)	Normal Condition	Diagnostic Note
WHEEL SPD RL	Wheel speed sensor (RL) reading / min.: 0 km/h (0 mph), max.: 326 km/h (202 mph)	Actual wheel speed	Similar speed as indicated on speedometer
WHEEL SPD RR	Wheel speed sensor (RR) reading / min.: 0 km/h (0 mph), max.: 326 km/h (202 mph)	Actual wheel speed	Similar speed as indicated on speedometer

OK:

There is almost no difference in the displayed speed value.

HINT:

There is tolerance of +/-10% in the speedometer indication.

NG

Go to step 4

OK

3 INSPECT SPEED SENSOR AND SENSOR ROTOR SERRATIONS

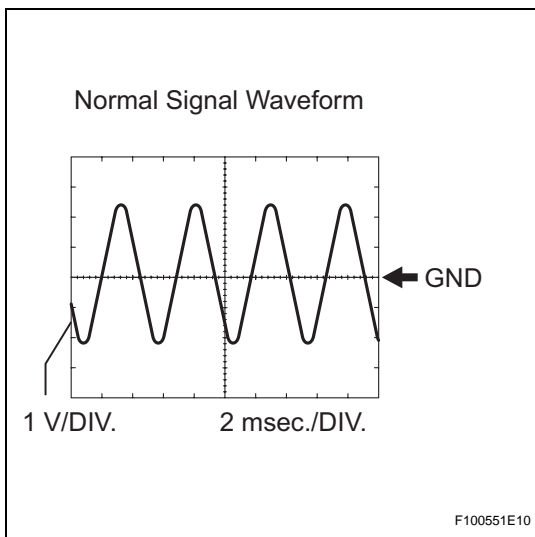

- (a) Connect the oscilloscope to terminals RR+ and RR-, or RL+ and RL- of the skid control ECU.
- (b) Drive the vehicle at approximately 30 km/h (19 mph), and check the signal waveform.

OK:

A waveform as shown should be output.

HINT:

- As the vehicle speed (wheel revolution speed) increases, a cycle of the waveform narrows and the fluctuation in the output voltage becomes greater.
- When noise is identified in the waveform on the oscilloscope, error signals are generated due to the speed sensor rotor's scratches, looseness or foreign matter deposited on it.

NG

Go to step 7

OK

REPLACE SKID CONTROL ECU

4 INSPECT REAR SPEED SENSOR

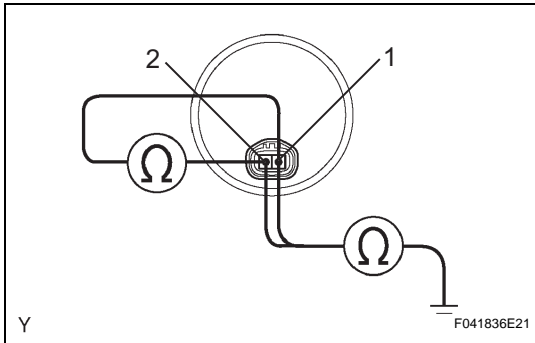

- (a) Disconnect the rear speed sensor connector.
- (b) Measure the resistance of the sensor.

Standard resistance

Tester Connection	Specified Condition
1 - 2	1.04 to 1.30 kΩ
1 - Body ground	10 kΩ or higher
2 - Body ground	10 kΩ or higher

NG → **REPLACE REAR SPEED SENSOR**

OK

5 CHECK WIRE HARNESS (SKID CONTROL ECU - REAR SPEED SENSOR)

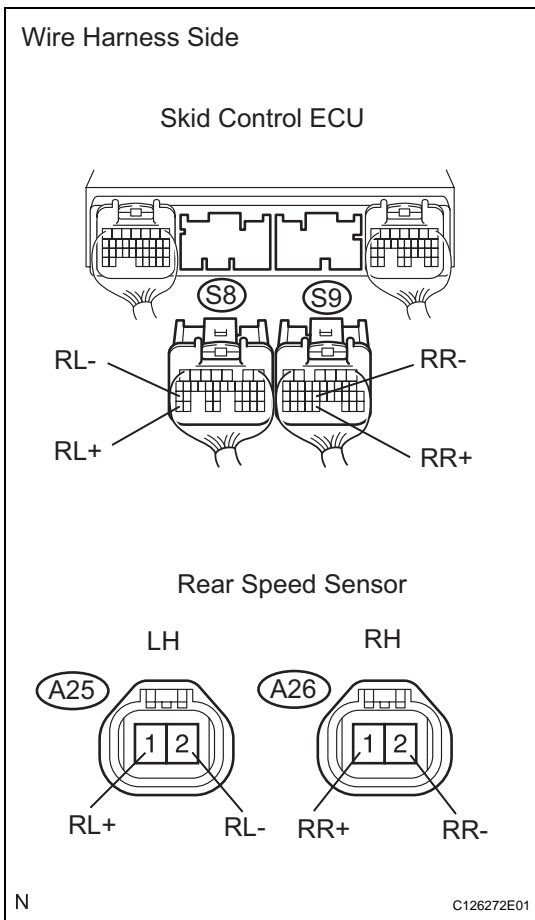

- (a) Disconnect the S8 and S9 ECU connectors.
- (b) Disconnect the A25 and A26 sensor connectors.
- (c) Measure the resistance of the wire harness side connectors.

Standard resistance:
for LH

Tester Connection	Specified Condition
A25-1 (RL+) - S8-35 (RL+)	Below 1 Ω
A25-2 (RL-) - S8-27 (RL-)	Below 1 Ω
A25-1 (RL+) - Body ground	10 kΩ or higher
A25-2 (RL-) - Body ground	10 kΩ or higher

for RH

Tester Connection	Specified Condition
A26-1 (RR+) - S9-31 (RR+)	Below 1 Ω
A26-2 (RR-) - S9-23 (RR-)	Below 1 Ω
A26-1 (RR+) - Body ground	10 kΩ or higher
A26-2 (RR-) - Body ground	10 kΩ or higher

NG → **REPAIR OR REPLACE HARNESS AND CONNECTOR**

OK

6 INSPECT SPEED SENSOR AND SENSOR ROTOR SERRATIONS

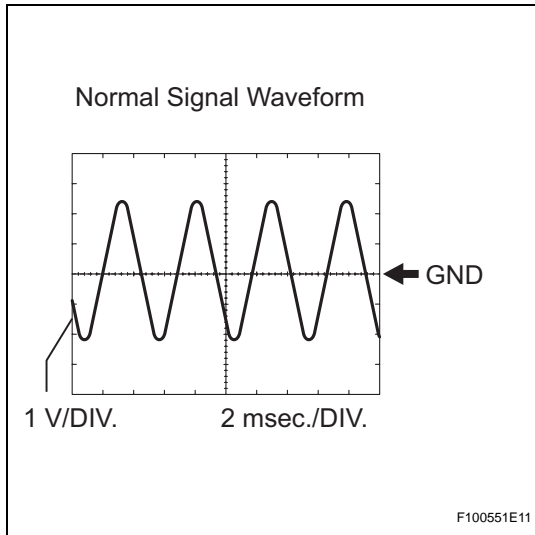

- Connect the oscilloscope to terminals RR+ and RR-, or RL+ and RL- of the skid control ECU.
- Drive the vehicle at approximately 30 km/h (19 mph), and check the signal waveform.

OK:

A waveform as shown should be output.

HINT:

- As vehicle speed (wheel revolution speed) increases, a cycle of the waveform narrows and the fluctuation in the output voltage becomes greater.
- When noise is identified in the waveform on the oscilloscope, error signals are generated due to the speed sensor rotor's scratches, looseness or foreign matter deposited on it.

NG

Go to step 7

OK

REPLACE SKID CONTROL ECU

7 REPLACE SKID CONTROL ECU

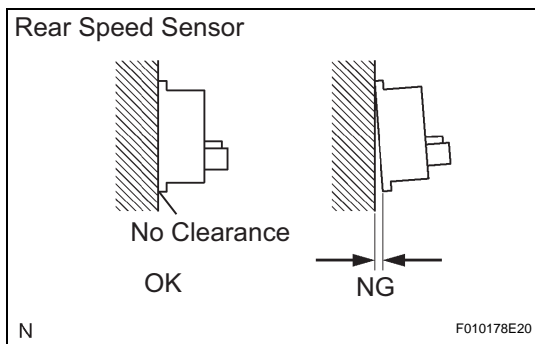

- Check the sensor installation.

OK:

There is no clearance between the sensor and rear axle carrier.

NOTICE:

Check the speed sensor signal after the replacement (see page [BC-23](#)).

NG

REPLACE REAR SPEED SENSOR

OK

DTC	C1202/68	Master Reservoir Level Malfunction
------------	-----------------	---

DESCRIPTION

When a fluid level drop in the master cylinder reservoir is detected, the signal is input to the skid control ECU. When the DTC for the fluid level drop is memorized, the warning is canceled if the fluid level returns to normal and the other DTCs are not input.

DTC No.	INF Code	DTC Detection Condition	Trouble Area
C1202/68	511	When either condition below is met: <ul style="list-style-type: none"> • Pump motor operates for specified period when reservoir level drops • Brake operation signal is input when the reservoir level is abnormal and the power switch is on. 	<ul style="list-style-type: none"> • Brake fluid level • Brake fluid level warning switch • Harness and connector • Skid control ECU
C1202/68	512	Open in switch signal circuit continues for 2 seconds or more.	<ul style="list-style-type: none"> • Brake fluid level switch • Harness and connector • Skid control ECU

WIRING DIAGRAM

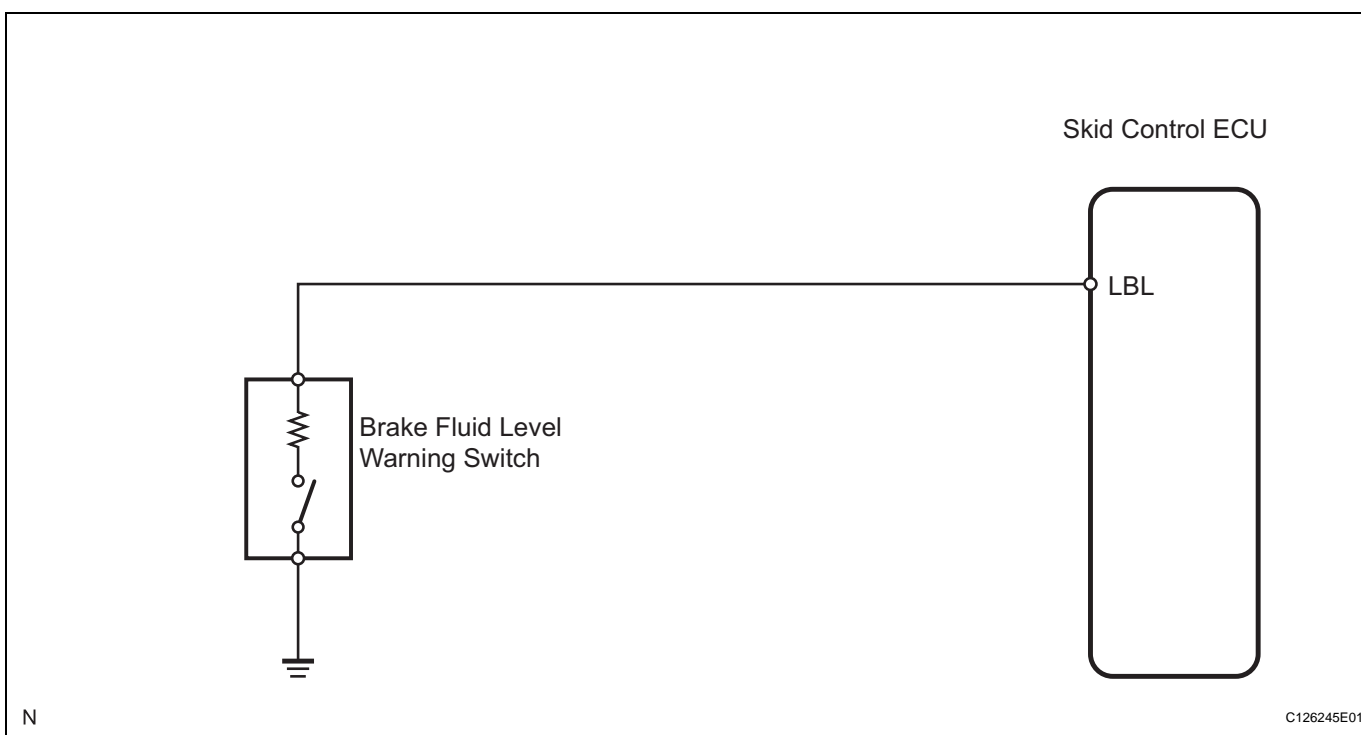

INSPECTION PROCEDURE

NOTICE:

When replacing the skid control ECU, perform initialization of linear solenoid valve and calibration (see page BC-19).

HINT:

When releasing the parking brake, set wheel chocks to hold the vehicle for safety.

1	CHECK BRAKE FLUID LEVEL IN RESERVOIR
----------	---

(a) Check that the brake fluid level is sufficient.

HINT:

- If the fluid level drops, check for a fluid leak, and repair if found.
- If no leaks exist, add and adjust fluid and then check that the trouble code is not output again.

OK:

Brake fluid level is proper.

NG → **ADD BRAKE FLUID**

OK

2 INSPECT BRAKE FLUID LEVEL WARNING SWITCH

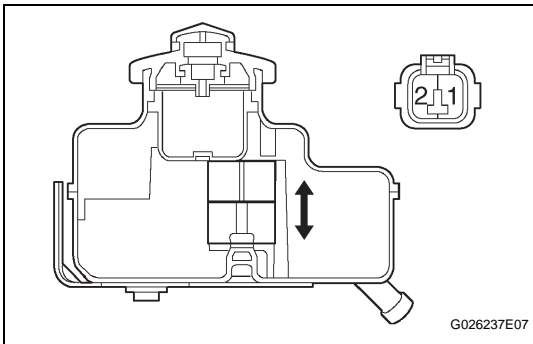

- Remove the reservoir tank cap and strainer.
- Disconnect the brake fluid level warning switch connector.
- Measure the resistance of the switch.

Standard resistance

Tester Connection	Fluid Level	Specified Condition
1 - 2	Proper	1.8 to 2.16 kΩ
1 - 2	Below minimum level	Below 1 Ω

NG → **REPLACE BRAKE MASTER CYLINDER RESERVOIR SUB-ASSEMBLY**

OK

3 CHECK WIRE HARNESS (SKID CONTROL ECU - BRAKE FLUID LEVEL WARNING SWITCH)

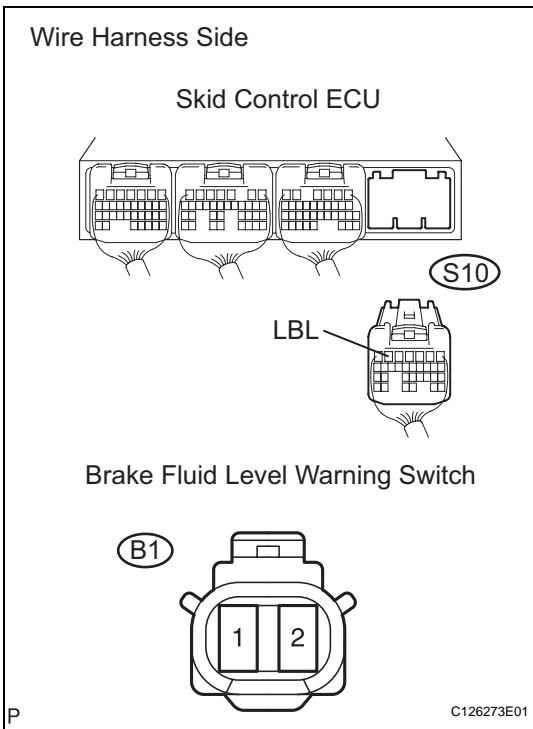

- Disconnect the S10 ECU connector.
- Disconnect the B1 switch connector.
- Measure the resistance of the wire harness side connectors.

Standard resistance

Tester Connection	Specified Condition
S10-6 (LBL) - B1-2	Below 1 Ω
S10-6 (LBL) - Body ground	10 kΩ or higher

NG → **REPAIR OR REPLACE HARNESS AND CONNECTOR**

OK

4 RECONFIRM DTC

- (a) Clear the DTCs (see page [BC-38](#)).
- (b) Turn the power switch ON (READY).
- (c) Check that the same DTCs are recorded (see page [BC-38](#)).

HINT:

This DTC may be memorized due to a malfunction in the connector terminal connection, etc.

Result

Result	Proceed to
DTC is output	A
DTC is not output	B

B

END

A

REPLACE SKID CONTROL ECU

DTC**C1203/95****ECM Communication Circuit Malfunction****DESCRIPTION**

DTC No.	INF Code	DTC Detection Condition	Trouble Area
C1203/95	-	When one of following conditions is met: <ul style="list-style-type: none"> No stored information for destination. No stored information whether VSC is in operation or not. Destination information from HV-ECU does not match with stored value. 	Skid control ECU

INSPECTION PROCEDURE**NOTICE:**

When replacing the skid control ECU, perform initialization of linear solenoid valve and calibration (see page [BC-19](#)).

1 CHECK DTC (HYBRID CONTROL SYSTEM)

- (a) Check if a hybrid control system DTC is output (see page [HV-55](#)).

Result

Result	Proceed to
DTC is not output	A
DTC is output	B

B**REPAIR HYBRID CONTROL SYSTEM****A****2 CHECK DTC (ELECTRONICALLY CONTROLLED BRAKE SYSTEM)**

- (a) Check if C1300/- is output.

Result

Result	Proceed to
C1300/- is not output	A
C1300/- is output	B

B**GO TO DTC C1300****A****REPLACE SKID CONTROL ECU**

DTC	C1210/36	Zero Point Calibration of Yaw Rate Sensor Undone
DTC	C0371/71	Yaw Rate Sensor (Test Mode DTC)
DTC	C1232/32	Stuck in Acceleration Sensor
DTC	C1234/34	Yaw Rate Sensor Malfunction
DTC	C1243/43	Acceleration Sensor Stuck Malfunction
DTC	C1244/44	Open or Short in Acceleration Sensor Circuit
DTC	C1245/45	Acceleration Sensor Output Malfunction
DTC	C1279/79	Acceleration Sensor Output Voltage Malfunction (Test Mode DTC)
DTC	C1336/39	Zero Point Calibration of Acceleration Sensor Undone
DTC	C1381/97	Yaw Rate and / or Acceleration Sensor Power Supply Voltage Malfunction

DESCRIPTION

The yaw rate (deceleration) sensor detects any gravity applied to the vehicle and transmit the signal to the skid control ECU via CAN communication system (vehicle equipped with Enhanced VSC). The deceleration sensor is built into the yaw rate sensor and detects the vehicle condition in the 2 systems (GL1, GL2).

When a malfunction occurs in the communication line with the yaw rate sensor, DTC U0123/62 (yaw rate sensor communication malfunction) and DTC U0124/95 (deceleration sensor communication malfunction) are output.

DTCs C0371/71 and C1279/79 are deleted when the yaw rate and deceleration sensor sends a yaw rate and/or deceleration signal or test mode ends. DTCs C0371/71 and C1279/79 are output only in test mode.

DTC No.	NF Code	DTC Detection Condition	Trouble Area
C1210/36	336	Yaw rate sensor zero point calibration is unfinished.	Zero point calibration undone (Perform zero point calibration and check DTC. If DTC is not output again, the sensor is normal.)
C0731/71	-	Detected only during test mode	<ul style="list-style-type: none"> Yaw rate (deceleration) sensor Yaw rate (deceleration) sensor circuit

DTC No.	NF Code	DTC Detection Condition	Trouble Area
C1232/32	311 312	One GL1/2 signal fluctuation is within 80 mV and the other is 1.9 V or more for at least 30 sec. when vehicle speed is 10 km/h (6 mph)	<ul style="list-style-type: none"> Yaw rate (deceleration) sensor Skid control ECU
C1234/34	331 332 333 334 335 337	Signal of malfunction that is detected at sensor self-check is received when communication with the sensors is valid.	Yaw rate (deceleration) sensor
C1243/43	317	Sensor sticking can be seen 16 times or more in a series at a speed between 30 km/h (18 mph) and 0 km/h (0 mph).	<ul style="list-style-type: none"> Yaw rate (deceleration) sensor Skid control ECU
C1244/44	314	Difference between GL1 and GL2 is not less than 0.4 G for at least 60 sec. after the difference is 0.6 G or more when the vehicle speed is 0 km/h (0 mph). Malfunction signal from deceleration sensor is received.	<ul style="list-style-type: none"> Yaw rate (deceleration) sensor Yaw rate (deceleration) sensor installation Zero point calibration not done Skid control ECU
C1245/45	313	Difference between the G value calculated from deceleration sensor value and vehicle speed exceeds 0.35 G for at least 60 sec. when vehicle speed is 30 km/h (18 mph).	<ul style="list-style-type: none"> Yaw rate (deceleration) sensor Yaw rate (deceleration) sensor installation Zero point calibration not done Skid control ECU
C1279/79	-	Detected only during test mode	<ul style="list-style-type: none"> Yaw rate (deceleration) sensor Yaw rate (deceleration) sensor circuit
C1336/39	318	Vehicle speed increases with unfinished zero point calibration. Zero point calculation is not within specified range when zero point calibration is finished.	Zero point calibration undone (Perform zero point calibration and check DTC. If DTC is not output again, the sensor is normal.)
C1381/97	315	Power source voltage is not within specified range when communication between skid control ECU and sensor is valid.	<ul style="list-style-type: none"> Yaw rate (deceleration) sensor circuit Harness and connector Skid control ECU

WIRING DIAGRAM

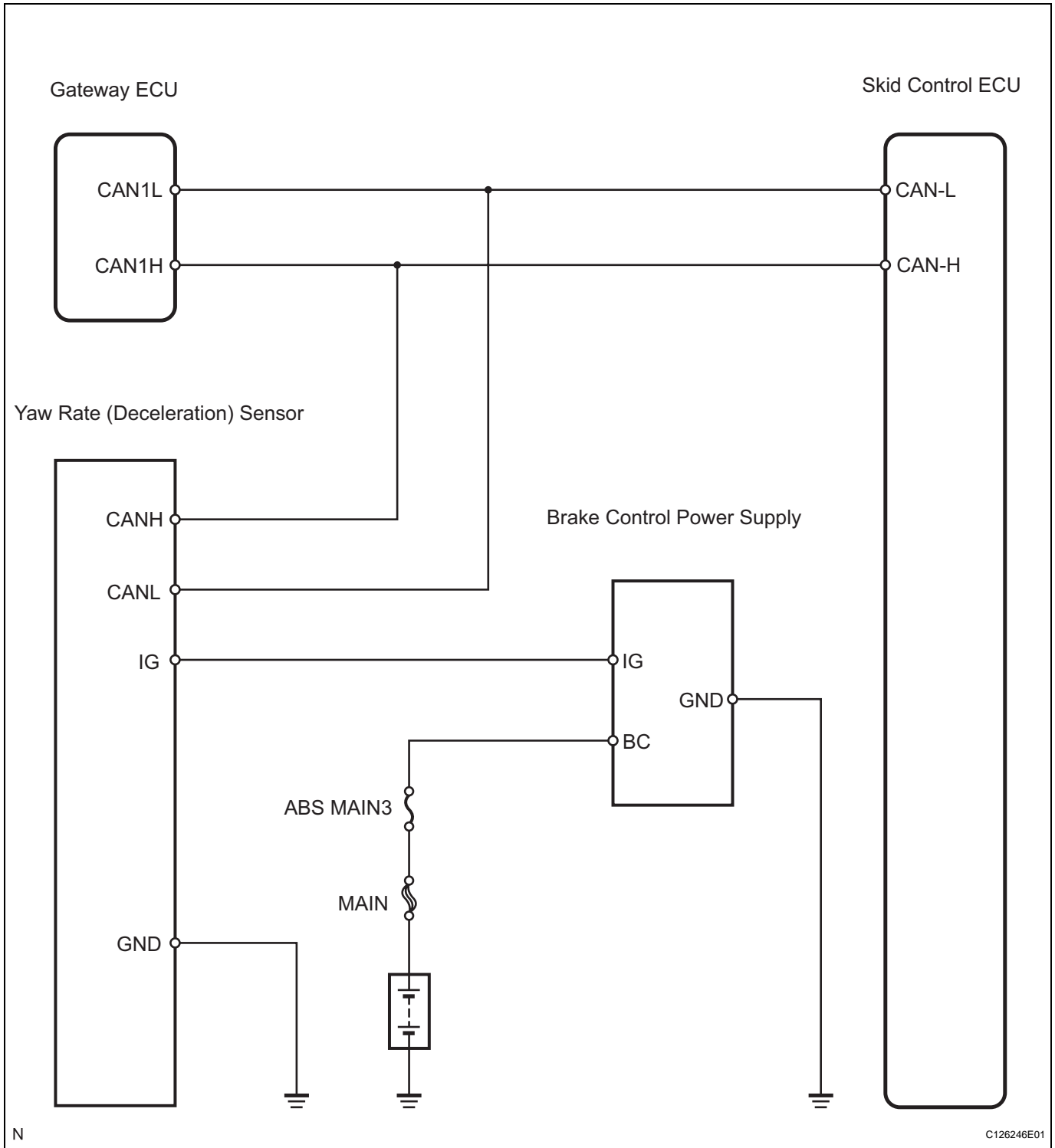

BC

INSPECTION PROCEDURE

1	CHECK DTC
----------	------------------

- (a) Clear the DTCs (see page [BC-38](#)).
- (b) Turn the power switch ON (READY).

- (c) Check that the trouble code for CAN communication DTCs U0073/94 and U0123/62 are not output.

Result

Result	Proceed to
CAN communication DTCs are not output.	A
CAN communication DTC U0073 or U0123/62 is output.	B
Only unfinished zero point calibration DTC C1210/36 or C1336/36 is output.	C

B → **REPAIR CIRCUIT INDICATED BY OUTPUT CODE**

C → **Go to step 5**

A

2 CHECK SENSOR INSTALLATION (YAW RATE (DECELERATION) SENSOR)

- (a) Check that the yaw rate (deceleration) sensor has been installed properly.

OK:

The sensor should be tightened to the specified torque.

The sensor should not be tilted.

NG → **INSTALL YAW RATE SENSOR CORRECTLY**

OK

3 CHECK WIRE HARNESS (YAW RATE SENSOR - BATTERY)

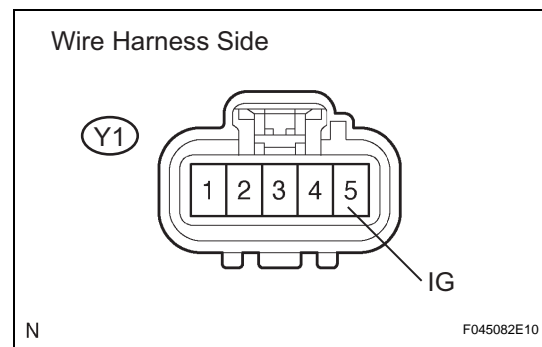

- (a) Disconnect the Y1 sensor connector.
- (b) Turn the power switch ON (READY).
- (c) Measure the voltage of the wire harness side connector.

Standard voltage

Tester Connection	Specified Condition
Y1-5 (IG) - Body ground	10 to 14 V

NG → **REPAIR OR REPLACE HARNESS AND CONNECTOR**

OK

4 CHECK WIRE HARNESS (YAW RATE SENSOR - BODY GROUND)

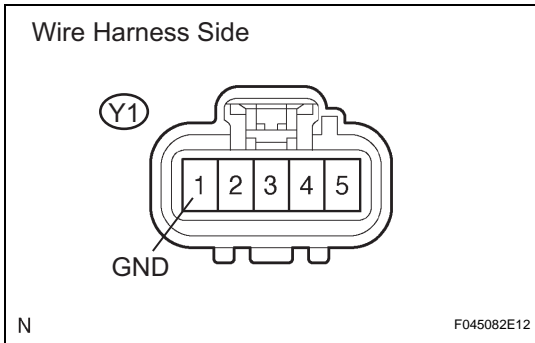

- (a) Disconnect the Y1 sensor connector.
- (b) Measure the resistance of the wire harness side connector.

Standard resistance

Tester Connection	Specified Condition
Y1-1 (GND) - Body ground	Below 1 Ω

NG → **REPAIR OR REPLACE HARNESS AND CONNECTOR**

OK

REPLACE YAW RATE SENSOR

5 PERFORM ZERO POINT CALIBRATION OF YAW RATE SENSOR AND DECELERATION SENSOR

- (a) Perform the zero point calibration of the yaw rate (deceleration) sensor (see page BC-21).

NEXT

6 RECONFIRM DTC

- (a) Clear the DTCs (see page BC-38).
- (b) Turn the power switch ON (READY).
- (c) Check the same DTCs are recorded (see page BC-38).

Result

Result	Proceed to
DTC is not output	A
DTC is output	B

HINT:

This DTC may be memorized due to a malfunction in the connector terminal.

B → **REPLACE YAW RATE SENSOR**

A

END

DTC**C1231/31****Steering Angle Sensor Circuit Malfunction****DESCRIPTION**

The skid control ECU inputs the steering sensor signal through the CAN communication. When a malfunction occurs in the communication line with the steering sensor, DTC U0126/63 (malfunction in communication with steering angle sensor) is output.

DTC No.	INF Code	DTC Detection Condition	Trouble Area
C1231/31	341 342 343 344 345 346 347 348 349	When either condition below is met: <ul style="list-style-type: none"> Steering angle sensor malfunction signal is received when data transmission is valid (internal malfunction is detected at sensor self-check). A signal of +B open in steering angle sensor is received when communication with sensor is valid. 	<ul style="list-style-type: none"> Steering angle sensor Skid control ECU

WIRING DIAGRAM

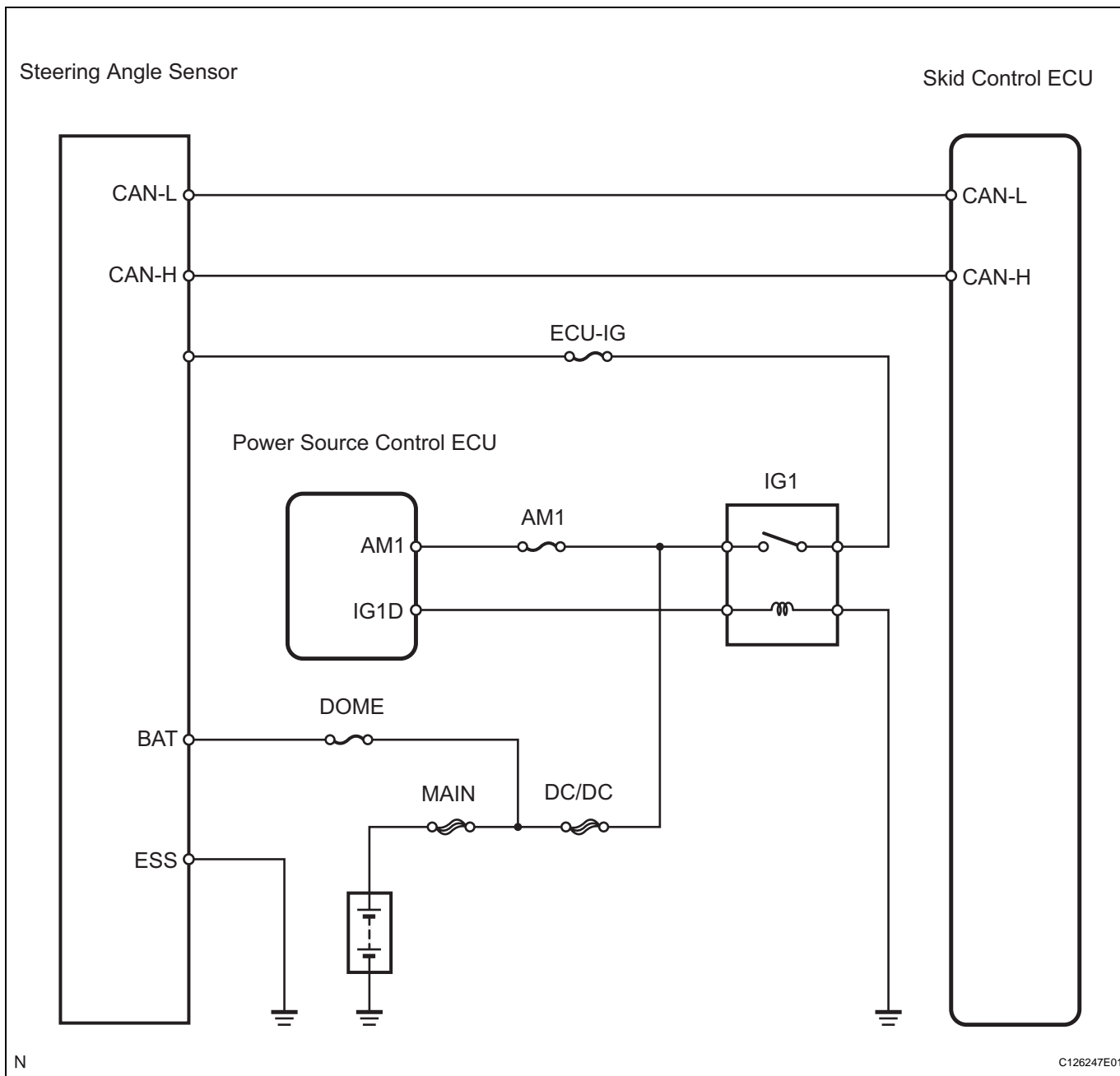

INSPECTION PROCEDURE

NOTICE:

When replacing the skid control ECU, perform initialization of linear solenoid valve and calibration (see page BC-19).

HINT:

- When U0126 is output together with C1231/31, inspect and repair the trouble areas indicated by U0126/63 first.
- When the speed sensor or the yaw rate (deceleration) sensor has trouble, DTCs for the steering angle sensor may be output even when the steering angle sensor is normal. When DTCs for the speed sensor or yaw rate sensor are output together with other DTCs for the steering angle sensor, inspect and repair the speed sensor and yaw rate (deceleration) sensor first, and then inspect and repair the steering angle sensor.

1 CHECK HARNESS AND CONNECTOR (MOMENTARY INTERRUPTION)

- (a) Using the intelligent tester, check for any momentary interruption in the wire harness and connectors between the skid control ECU and steering angle sensor (see page BC-17).

Skid control ECU

Item	Measurement Item / Range (Display)	Normal Condition	Diagnostic Note
STEERING SEN	Steering sensor open detection / OPN-DET or NORMAL	NORMAL: Normal condition	-

OK:
There are no momentary interruptions.

NG → **REPAIR OR REPLACE HARNESS AND CONNECTOR**

OK

2 READ VALUE OF INTELLIGENT TESTER (STEERING ANGLE SENSOR)

- (a) Check the DATA LIST for proper functioning of the steering angle sensor.

Skid control ECU

Item	Measurement Item / Range (Display)	Normal Condition	Diagnostic Note
STEERING ANG	Steering sensor / Min.: -1152 deg, Max.: 1150.875 deg	Left turn: Increase Right turn: Decrease	-

OK:
Steering angle value should change.

OK → **REPLACE SKID CONTROL ECU**

NG

3 CHECK WIRE HARNESS (STEERING ANGLE SENSOR - BATTERY AND BODY GROUND)

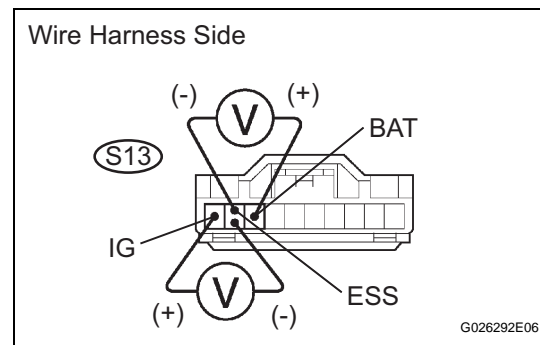

- (a) Remove the steering wheel and the column lower cover.
- (b) Disconnect the S13 sensor connector.
- (c) Turn the power switch ON (READY).
- (d) Measure the voltage of the wire harness side connector.

Standard voltage

Tester Connection	Specified Condition
S13-1 (IG) - S13-2 (ESS)	10 to 14 V
S13-3 (BAT) - S13-2 (ESS)	10 to 14 V

NG → **REPAIR OR REPLACE HARNESS AND CONNECTOR**

OK

REPLACE STEERING ANGLE SENSOR

DTC	C1235/35	Foreign Object is Attached on Tip of Front Speed Sensor RH
DTC	C1236/36	Foreign Object is Attached on Tip of Front Speed Sensor LH
DTC	C1238/38	Foreign Object is Attached on Tip of Rear Speed Sensor RH
DTC	C1239/39	Foreign Object is Attached on Tip of Rear Speed Sensor LH
DTC	C1275/75	Abnormal Change in Output Signal of Front Speed Sensor RH (Test Mode DTC)
DTC	C1276/76	Abnormal Change in Output Signal of Front Speed Sensor LH (Test Mode DTC)
DTC	C1277/77	Abnormal Change in Output Signal of Rear Speed Sensor RH (Test Mode DTC)
DTC	C1278/78	Abnormal Change in Output Signal of Rear Speed Sensor LH (Test Mode DTC)

DESCRIPTION

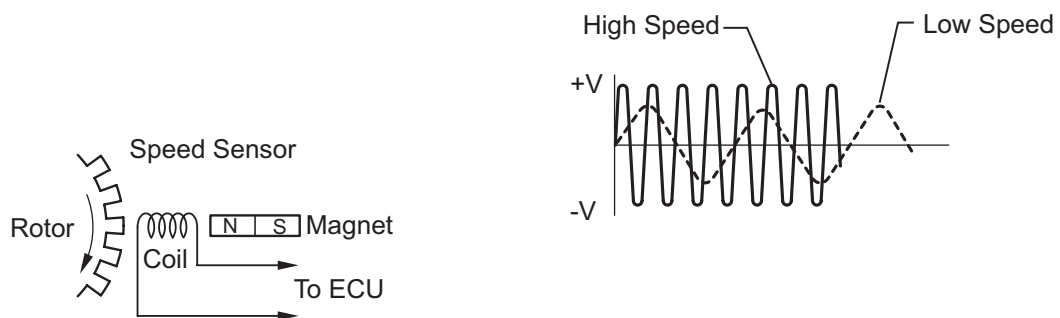

C108865E02

The speed sensor detects wheel speed and sends the appropriate signals to the ECU. These signals are used to control the ABS control system. The front and rear rotors have 48 serrations respectively.

When the rotors rotate, the magnetic field emitted by the permanent magnet in the speed sensor generates an AC voltage. Since the frequency of this AC voltage changes in direct proportion to the speed of the rotor, the frequency is used by the ECU to detect the speed of each wheel. When foreign matter adheres to the speed sensor tip or sensor rotor, or the rotor teeth are chipped, these DTCs are output. An abnormal waveform input from the sensor determines these conditions.

These DTCs may be detected when a malfunction occurs in the connector terminals or wire harness of the speed sensor circuit.

DTCs C1275/75, C1276/76, C1277/77 and C1278/78 can be deleted when the speed sensor sends a vehicle speed signal or the test mode ends. DTCs C1275/75, C1276/76, C1277/77 and C1278/78 are output only in the test mode.

DTC No.	INF Code	DTC Detection Condition	Trouble Area
C1235/35	302	Pulse waveform of speed sensor signal is abnormal for at least 5 sec. when vehicle speed is 20 km/h (12 mph) or more.	<ul style="list-style-type: none"> • Right front speed sensor • Each speed sensor circuit • Sensor installation • Skid control ECU
C1236/36	303	Pulse waveform of speed sensor signal is abnormal for at least 5 sec. when vehicle speed is 20 km/h (12 mph) or more.	<ul style="list-style-type: none"> • Left front speed sensor • Each speed sensor circuit • Sensor installation • Skid control ECU
C1238/38	304	Pulse waveform of speed sensor signal is abnormal for at least 5 sec. when vehicle speed is 20 km/h (12 mph) or more.	<ul style="list-style-type: none"> • Right rear speed sensor • Each speed sensor circuit • Skid control ECU
C1239/39	305	Pulse waveform of speed sensor signal is abnormal for at least 5 sec. when vehicle speed is 20 km/h (12 mph) or more.	<ul style="list-style-type: none"> • Left rear speed sensor • Each speed sensor circuit • Skid control ECU
C1275/75 C1276/76	-	Detected only during test mode	<ul style="list-style-type: none"> • Front speed sensor • Front speed sensor circuit • Sensor installation
C1275/77 C1276/78	-	Detected only during test mode	<ul style="list-style-type: none"> • Rear speed sensor • Rear speed sensor circuit • Sensor installation

HINT:

- DTC C1235/35 is for the right front speed sensor.
- DTC C1236/36 is for the left front speed sensor.
- DTC C1238/38 is for the right rear speed sensor.
- DTC C1239/39 is for the left rear speed sensor.

WIRING DIAGRAM

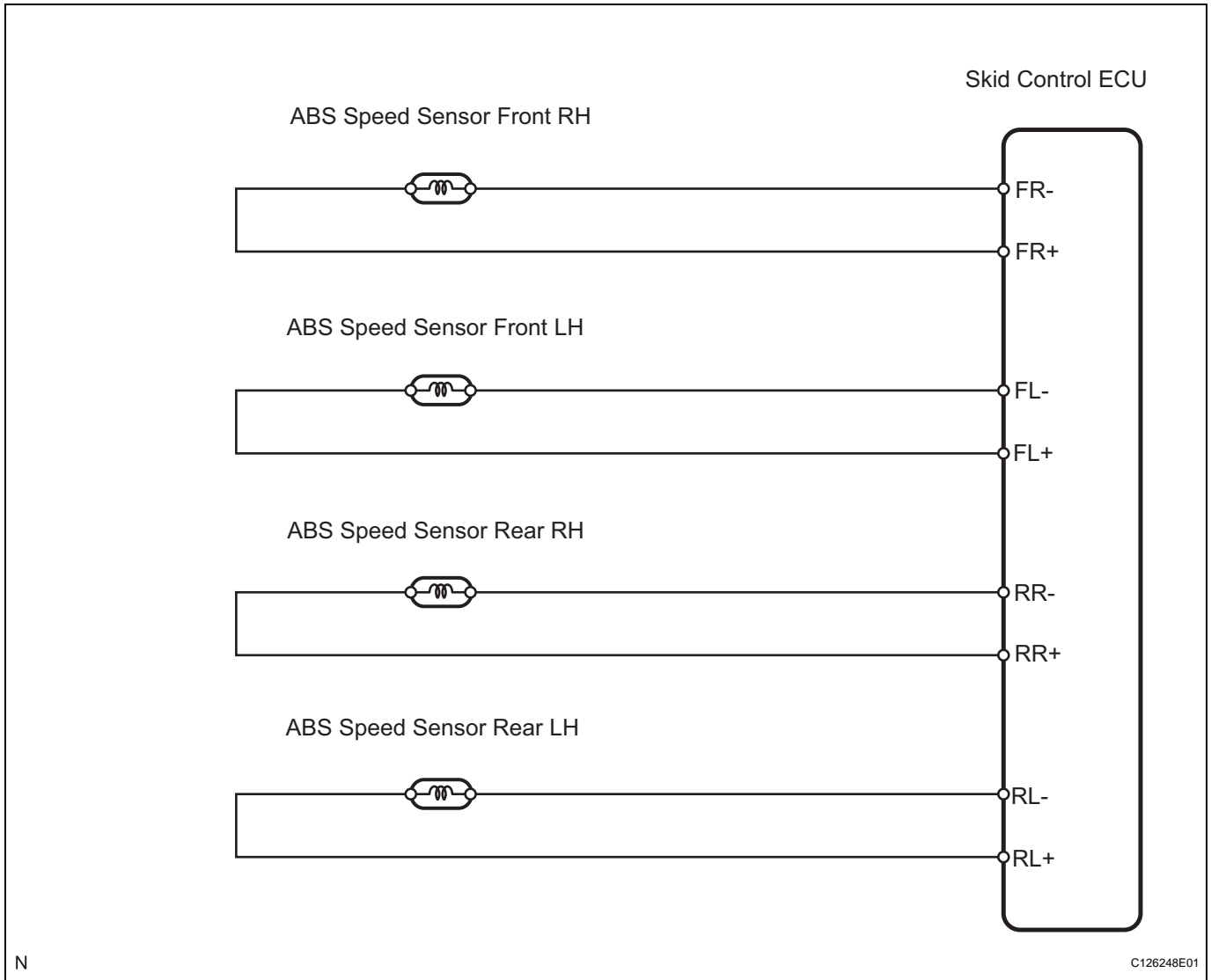

INSPECTION PROCEDURE

1 CHECK SPEED SENSOR AND SENSOR ROTOR SERRATIONS

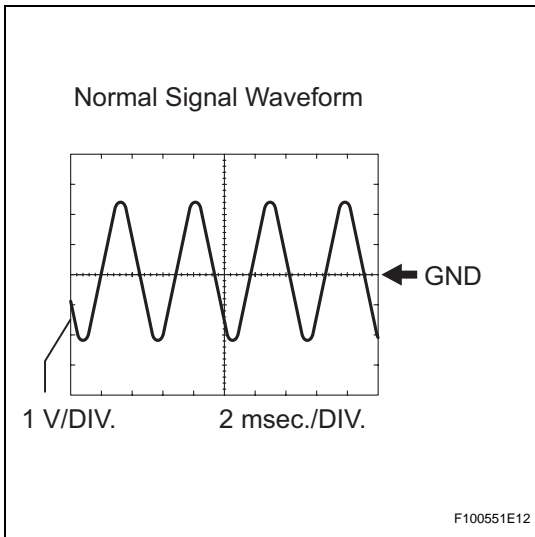

- (a) Connect the oscilloscope to terminal FR+ and FR-, or FL+ and FL- of the skid control ECU.
- (b) Drive the vehicle at approximately 30 km/h (19 mph), and check the signal waveform.

OK:

A waveform as shown should be output.

- As the vehicle speed (wheel revolution speed) increases, a cycle of the waveform narrows and the fluctuation in the output voltage becomes greater.
- When noise is identified in the waveform on the oscilloscope, error signals are generated due to the speed sensor rotor's scratches, looseness or foreign matter deposited on it.

NG → **Go to step 4**

OK

2 CHECK SPEED SENSOR AND SENSOR ROTOR SERRATIONS

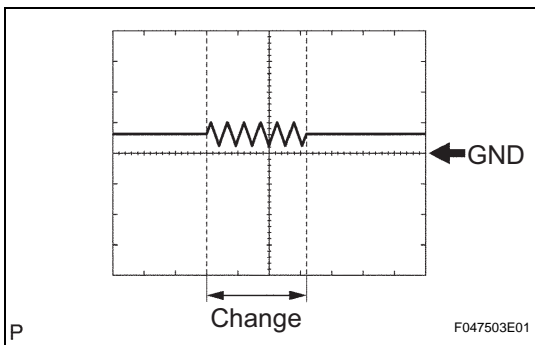

- (a) Connect the oscilloscope to terminal FR+ and FR-, or FL+ and FL- of the skid control ECU.
- (b) Check if the oscilloscope has any change when the wire harness connector is subject to vibration while the vehicle is stopped and the power switch is ON (IG). (If the connector is poorly connected, vibration of the wire harness connector may cause a temporary stop in current flow.)

OK:

There is no change in a waveform.

NG → **REPAIR OR REPLACE HARNESS AND CONNECTOR**

OK

3 RECONFIRM DTC

- (a) Clear the DTCs (see page [BC-38](#)).
- (b) Turn the power switch ON (READY).
- (c) Check the same DTCs are recorded (see page [BC-38](#)).

Result

Result	Proceed to
DTC is not output	A
DTC is output	B

B → **REPLACE SKID CONTROL ECU**

A

PROCEED TO NEXT CIRCUIT INSPECTION SHOWN IN PROBLEM SYMPTOMS TABLE

4 INSPECT SPEED SENSOR TIP

- (a) Remove the front axle hub and front speed sensor.
- (b) Check the sensor tip.

OK:**No scratches or foreign matter on the sensor tip.****NOTICE:****Check the speed sensor signal after the replacement (see page BC-23).**

NG

CLEAN OR REPLACE SPEED SENSOR

OK

5 INSPECT SPEED SENSOR ROTOR

- (a) Remove the front axle hub and front speed sensor rotor.
- (b) Check the sensor rotor serrations.

OK:**No scratches, missing teeth or foreign matter on the rotors.****HINT:**

If there is foreign matter in the rotor, remove it and check the output waveform after reassembly.

NOTICE:**Check the speed sensor signal after the replacement (see page BC-23).**

NG

CLEAN OR REPLACE SPEED SENSOR ROTOR

OK

REPLACE SPEED SENSOR

DTC	C1241/41	Low Battery Positive Voltage or Abnormally High Battery Positive Voltage
------------	-----------------	---

DTC	C1242/42	Open in IG1 / IG2 Power Source Circuit
------------	-----------------	---

DESCRIPTION

These codes are memorized when the power source voltage for the skid control ECU drops or the voltage for the ABS NO. 1, ABS NO. 2 relay operation drops.

Codes may be memorized when the voltage of the auxiliary battery temporarily drops.

When the power source voltage is too high, the skid control ECU stops functioning and outputs no DTCs, and the ABS and BRAKE warning light remain on.

HINT:

DTC C1256/56 (accumulator low voltage malfunction) may be memorized if the power source voltage drops.

DTC No.	Detailed Code	DTC Detection Condition	Trouble Area
C1241/41	81	System 1 is under the following conditions when READY is on: <ul style="list-style-type: none"> Linear solenoid cannot receive enough current (brake is applied). BS voltage is less than 8.9 V for at least 3 sec. (brake is not applied). 12 V-power source voltage inside ECU is less than 8.5 V when main relay is opened or VCM voltage is less than 4.7 V or 5 V or more for at least 0.05 sec. 	<ul style="list-style-type: none"> ABS NO. 1 relay Harness and connector Skid control power supply circuit Brake control power supply assembly Hybrid control system
C1241/41	82	System 2 is under the following conditions when READY is on: <ul style="list-style-type: none"> Linear solenoid cannot receive enough current (brake is applied). BS voltage is less than 8.9 V for at least 3 sec. (brake is not applied). 12 V-power source voltage inside ECU is less than 8.5 V when main relay is opened or VCM voltage is less than 4.7 V or 5.3 V or more for at least 0.05 sec. 	<ul style="list-style-type: none"> ABS NO. 2 relay Harness and connector Skid control power supply circuit Brake control power supply assembly Hybrid control system
C1241/41	83	Capacitor mode signal is received from brake control power supply for 3 sec. or more when READY is on.	<ul style="list-style-type: none"> Brake control power supply assembly Brake control power supply Hybrid control system
C1241/41	84	ABS is requested to operate when the power source voltage of the main relay system is dropping.	<ul style="list-style-type: none"> ABS NO. 1 relay ABS NO. 2 relay Harness and connector
C1242/42	87	Voltage is applied to IG2 terminal, but not applied to IG1 terminal for at least 4 sec.	<ul style="list-style-type: none"> ABS NO. 1 relay Harness and connector Skid control power supply circuit Brake control power supply assembly Hybrid control system

DTC No.	Detailed Code	DTC Detection Condition	Trouble Area
C1242/42	88	Voltage is applied to IG1 terminal, but not applied to IG2 terminal for at least 4 sec.	<ul style="list-style-type: none">• ABS NO. 2 relay• Harness and connector• Skid control power supply circuit• Brake control power supply assembly• Hybrid control system

WIRING DIAGRAM

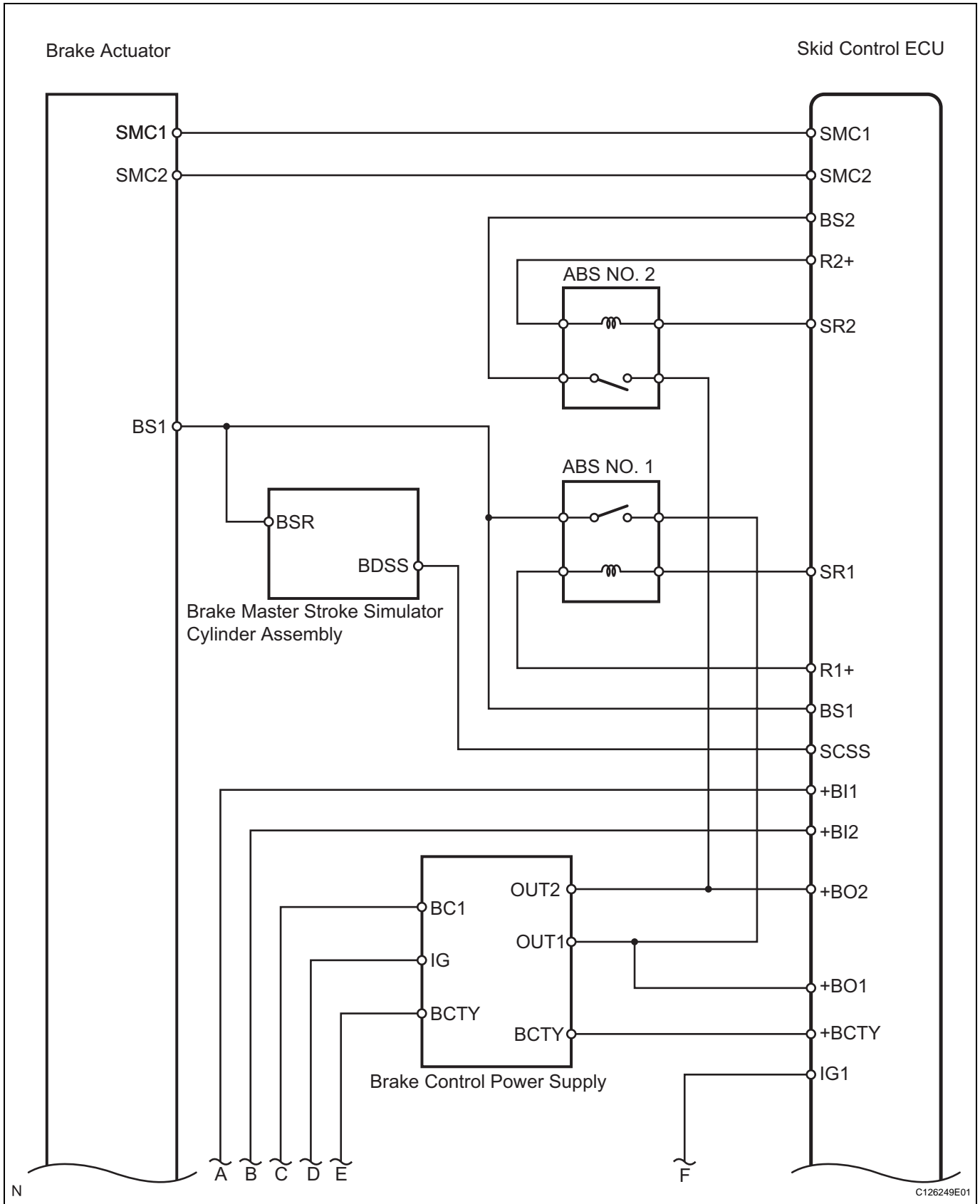

BC

C126249E01

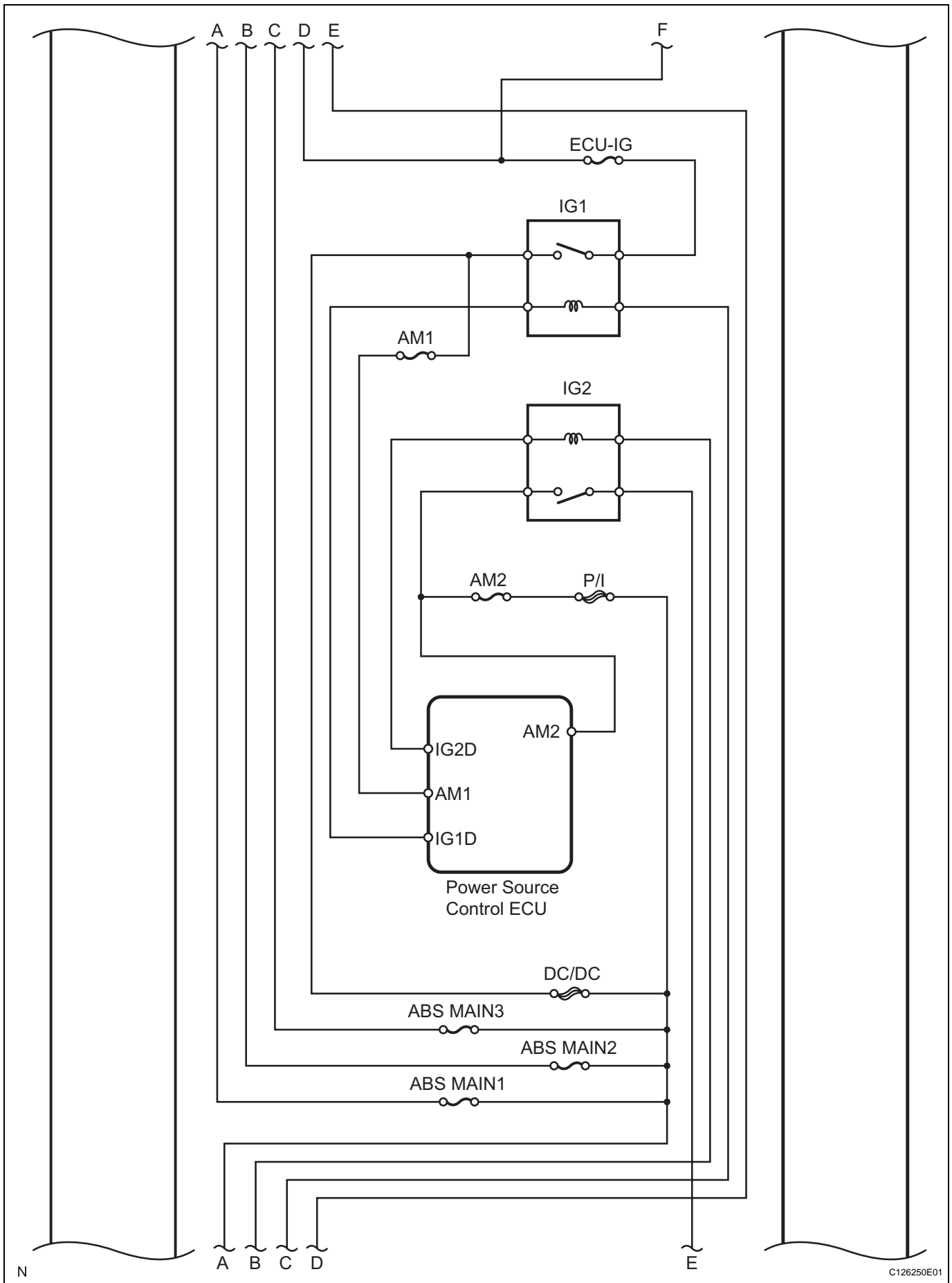

BC

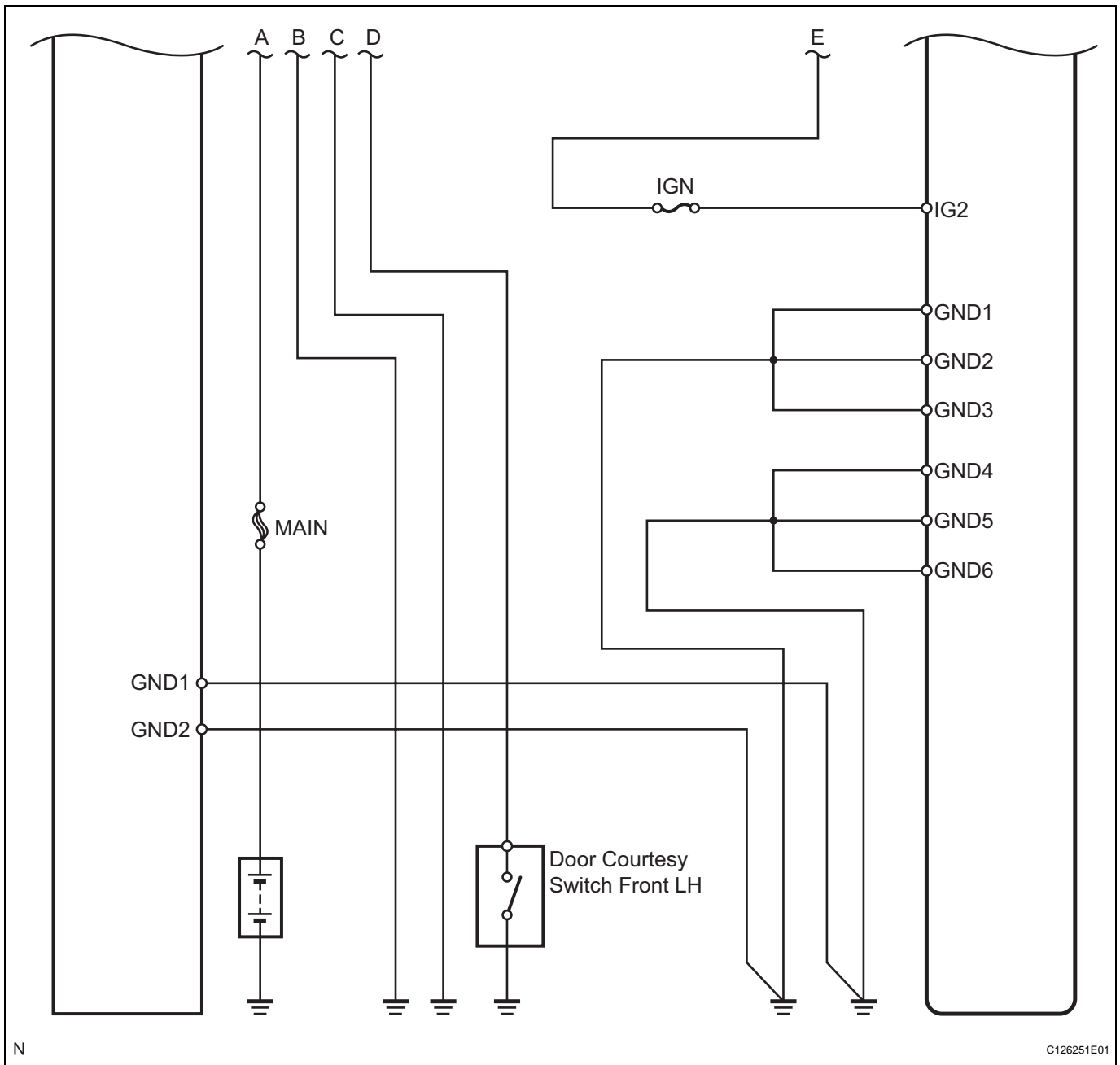

INSPECTION PROCEDURE

1 CHECK DTC (HYBRID CONTROL SYSTEM)

BC

(a) Check that hybrid control system DTCs are output.

Result

Result	Proceed to
DTC is not output	A
DTC is output	B

B REPAIR HYBRID CONTROL SYSTEM

A

2 CHECK AUXILIARY BATTERY VOLTAGE

(a) Check the auxiliary battery voltage.

Standard voltage:

10 to 14 V

NG → **CHARGE OR REPLACE AUXILIARY BATTERY**

OK

3 CHECK BRAKE CONTROL POWER SUPPLY (IG VOLTAGE)

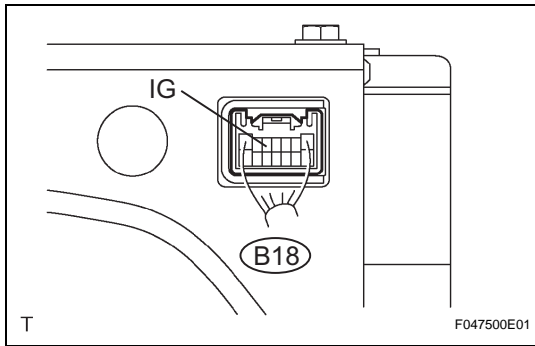

(a) Measure the voltage of the connector.

Standard voltage

Tester Connection	Condition	Specified Condition
B18-5 (IG) - Body ground	Power switch ON (READY)	10 to 14 V

NG → **REPLACE BRAKE CONTROL POWER SUPPLY**

OK

4 CHECK SKID CONTROL ECU

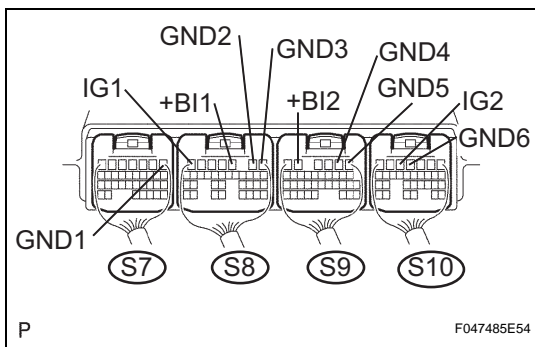

(a) Measure the voltage of the connectors.

HINT:

Measure the voltage from behind the connector with the connector connected to the skid control ECU.

Standard voltage

Tester Connection	Condition	Specified Condition
S8-7 (IG1) - Body ground	Power switch ON (READY)	10 to 14 V
S10-5 (IG2) - Body ground	Power switch ON (READY)	10 to 14 V
S8-3 (+BI1) - Body ground	Always	10 to 14 V
S9-5 (+BI2) - Body ground	Always	10 to 14 V

(b) Measure the resistance of the connectors.

Standard resistance

Tester Connection	Specified Condition
S7-1 (GND1) - Body ground	Below 1 Ω
S8-2 (GND2) - Body ground	Below 1 Ω
S8-1 (GND3) - Body ground	Below 1 Ω
S9-2 (GND4) - Body ground	Below 1 Ω
S9-1 (GND5) - Body ground	Below 1 Ω
S10-4 (GND6) - Body ground	Below 1 Ω

NG **REPAIR OR REPLACE HARNESS AND CONNECTOR**

OK

5 CHECK SKID CONTROL ECU (BS1, R1+, SR1, BS2, R2+, DSR2 VOLTAGE)

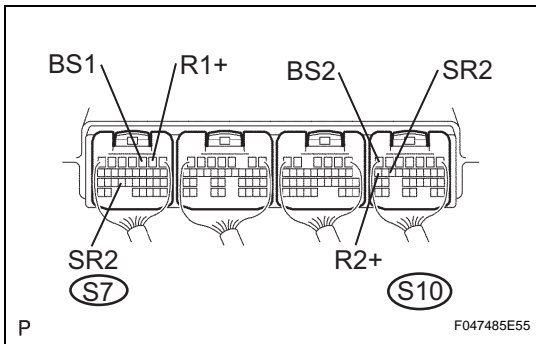

(a) Measure the voltage of the connectors.
HINT:
 Measure the voltage from behind the connector with the connector connected to the skid control ECU.
Standard voltage

Tester Connection	Condition	Specified Condition
S7-2 (R1+) - Body ground	Power switch ON (READY)	8 to 13 V
S10-17 (R2+) - Body ground	Power switch ON (READY)	8 to 13 V
S7-12 (SR1) - Body ground	Power switch ON (READY)	Below 1.5 V
S10-15 (SR2) - Body ground	Power switch ON (READY)	Below 1.5 V
S7-3 (BS1) - Body ground	Power switch ON (READY)	10 to 14 V
S10-7 (BS2) - Body ground	Power switch ON (READY)	10 to 14 V

Result

Result	Proceed to
All OK	A
NG (R1+, R2+)	B
NG (SR1, SR2, BS1, BS2)	C

B **REPLACE SKID CONTROL ECU**

C **REPAIR OR REPLACE HARNESS AND CONNECTOR**

A

6 RECONFIRM DTC

- (a) Clear the DTCs (see page [BC-38](#)).
- (b) Turn the power switch ON (READY).
- (c) Check the same DTCs are recorded (see page [BC-38](#)).

Result

Result	Proceed to
DTC is not output	A
DTC is output	B

B **REPLACE SKID CONTROL ECU**



END (DTC MAY BE STORED DUE TO TEMPORARY POWER SOURCE VOLTAGE DROP)

DTC	C1246/46	Master Cylinder Pressure Sensor Malfunction
DTC	C1281/81	Master Cylinder Pressure Sensor Output Malfunction (Test Mode DTC)
DTC	C1364/61	Wheel Cylinder Pressure Sensor Malfunction

DESCRIPTION

The master cylinder pressure sensor and the wheel cylinder pressure sensor are built into the brake actuator, and measure the master cylinder pressure and the wheel cylinder pressure sent to the skid control ECU.

DTC C1281/81 can be detected when the master cylinder pressure sensor sends a master cylinder pressure signal or test mode ends. DTC C1281/81 is output only in test mode.

DTC No.	INF Code	DTC Detection Condition	Trouble Area
C1246/46	191	Sensor power source 1 (VCM1) voltage is less than 4.7 V or 5.3 V or more for at least 0.05 sec.	<ul style="list-style-type: none"> • Brake actuator assembly • Skid control ECU • Harness and connector
C1246/46	192	Ratio of master pressure sensor output voltage 1 (PMC1) to sensor power source (VCM1) is less than 5% or 90.5% or more for at least 0.05 sec.	<ul style="list-style-type: none"> • Brake actuator assembly • Skid control ECU • Harness and connector
C1246/46	194	Sensor power source 2 (VCM2) voltage is less than 4.7 V or 5.3 V or more for at least 0.05 sec.	<ul style="list-style-type: none"> • Brake actuator assembly • Skid control ECU • Harness and connector
C1246/46	195	Ratio of master pressure sensor output voltage 2 (PMC2) to sensor power source (VCM2) is less than 5% or 90.5% or more for at least 0.05 sec.	<ul style="list-style-type: none"> • Brake actuator assembly • Skid control ECU • Harness and connector
C1246/46	197	Master pressure sensor output voltage 1 (PMC1) is abnormal.	<ul style="list-style-type: none"> • Brake actuator assembly • Skid control ECU
C1246/46	198	Master pressure sensor output voltage 2 (PMC2) is abnormal.	<ul style="list-style-type: none"> • Brake actuator assembly • Skid control ECU
C1246/46	199	Master pressure sensor output 1 (PMC1) is not approx. 0 Mpa when not braking.	<ul style="list-style-type: none"> • Brake actuator assembly • Skid control ECU • Harness and connector • Stop input signal
C1246/46	200	Master pressure sensor output 2 (PMC2) is not approx. 0 Mpa when not braking.	<ul style="list-style-type: none"> • Brake actuator assembly • Skid control ECU • Harness and connector • Stop input signal
C1246/46	201	PMC1 and PMC2 voltages are different when braking.	<ul style="list-style-type: none"> • Brake actuator assembly • Skid control ECU • Harness and connector
C1246/46	202	Master pressure sensor 1 data (PMC1) is invalid.	<ul style="list-style-type: none"> • Brake actuator assembly • Skid control ECU • Harness and connector
C1246/46	205	Master pressure sensor 2 data (PMC2) is invalid.	<ul style="list-style-type: none"> • Brake actuator assembly • Skid control ECU • Harness and connector
C1281/81	-	Detected only during test mode.	<ul style="list-style-type: none"> • Brake actuator assembly • Skid control ECU
C1364/61	221	Sensor power source 1 (VCM1) voltage is less than 4.7 V or 5.3 V or more for at least 0.05 sec.	<ul style="list-style-type: none"> • Harness and connector • Skid control ECU

DTC No.	INF Code	DTC Detection Condition	Trouble Area
C1364/61	222	Ratio of FR right sensor output voltage (PFR) to sensor power source (VCM1) is less than 5% or 90.5% or more for at least 0.05 sec.	<ul style="list-style-type: none"> • Brake actuator assembly • Skid control ECU • Harness and connector
C1364/61	224	When one of following conditions is met: <ul style="list-style-type: none"> • FR right sensor output (PFR) is not approx. 0 Mpa when not braking. • FR right sensor (PFR) zero point malfunction. • Open or short in FR right sensor (PFR) circuit. 	<ul style="list-style-type: none"> • Brake actuator assembly • Skid control ECU • Harness and connector
C1364/61	225	Ratio of FR right sensor output voltage (PFR) to sensor power source (VCM1) is less than 90.5% for at least 0.1 sec. when self-diagnosis signal is output.	<ul style="list-style-type: none"> • Brake actuator assembly • Skid control ECU • Harness and connector
C1364/61	226	Voltage difference before and after changing the pull-up resistance in the sensor signal input circuit is 0.3 V or more (poor connection).	<ul style="list-style-type: none"> • Brake actuator assembly • Skid control ECU • Harness and connector
C1364/61	227	Sensor power source 2 (VCM2) voltage is less than 4.7 V or 5.3 V or more for at least 0.05 sec.	<ul style="list-style-type: none"> • Brake actuator assembly • Skid control ECU • Harness and connector
C1364/61	228	Ratio of FR left sensor output voltage (PFL) to sensor power source (VCM2) is less than 5% or 90.5% or more for at least 0.05 sec.	<ul style="list-style-type: none"> • Brake actuator assembly • Skid control ECU • Harness and connector
C1364/61	230	When one of following conditions is met: <ul style="list-style-type: none"> • FR left sensor (PFL) is not approx. 0 Mpa when not braking. • FR left sensor (PFL) zero point malfunction • Open or short in FR right sensor (PFL) circuit. 	<ul style="list-style-type: none"> • Brake actuator assembly • Skid control ECU • Harness and connector
C1364/61	231	Ratio of FR left sensor output voltage (PFL) to sensor power source (VCM2) is less than 90.5% for at least 0.1 sec. when self-diagnosis signal is output.	<ul style="list-style-type: none"> • Brake actuator assembly • Skid control ECU • Harness and connector
C1364/61	232	Voltage difference before and after changing the pull-up resistance in the sensor signal input circuit is 0.3 V or more (poor connection).	<ul style="list-style-type: none"> • Brake actuator assembly • Skid control ECU • Harness and connector
C1364/61	233	Sensor power source 2 (VCM2) voltage is less than 4.7 V or 5.3 V or more for at least 0.05 sec.	<ul style="list-style-type: none"> • Brake actuator assembly • Skid control ECU • Harness and connector
C1364/61	234	Ratio of RR right sensor output voltage (PRR) to sensor power source (VCM2) is less than 5% or 90.5% or more for at least 0.05 sec.	<ul style="list-style-type: none"> • Brake actuator assembly • Skid control ECU • Harness and connector

DTC No.	INF Code	DTC Detection Condition	Trouble Area
C1364/61	236	When one of following conditions is met: <ul style="list-style-type: none"> RR right sensor output voltage (PRR) is not approx. 0 Mpa when not braking. RR right sensor (PRR) zero point malfunction. Open or short in RR sensor (PRR) circuit. 	<ul style="list-style-type: none"> Brake actuator assembly Skid control ECU Harness and connector
C1364/61	237	Ratio of RR right sensor output voltage (PRR) to sensor power source (VCM2) is less than 90.5% for at least 0.1 sec. when self-diagnosis signal is output.	<ul style="list-style-type: none"> Brake actuator assembly Skid control ECU Harness and connector
C1364/61	238	Voltage difference before and after changing the pull-up resistance in the sensor signal input circuit is 0.3 V or more (poor connection).	<ul style="list-style-type: none"> Brake actuator assembly Skid control ECU Harness and connector
C1364/61	239	Sensor power source (VCM1) voltage is less than 4.7 V or 5.3 V or more for at least 0.05 sec.	<ul style="list-style-type: none"> Brake actuator assembly Skid control ECU Harness and connector
C1364/61	240	Ratio of RR left sensor output voltage (PRL) to sensor power source (VCM1) is less than 5% or 90.5% or more for at least 0.05 sec.	<ul style="list-style-type: none"> Brake actuator assembly Skid control ECU Harness and connector
C1364/61	242	When one of following conditions is met: <ul style="list-style-type: none"> RR left sensor output (PRL) is not approx. 0 Mpa when not braking. RR left sensor (PRL) zero point malfunction. Open or short in RR left sensor (PRL) circuit. 	<ul style="list-style-type: none"> Brake actuator assembly Skid control ECU Harness and connector
C1364/61	243	Ratio of RR left sensor output voltage (PRL) to sensor power source (VCM1) is less than 90.5% for at least 0.1 sec. when self-diagnosis signal is output.	<ul style="list-style-type: none"> Brake actuator assembly Skid control ECU Harness and connector
C1364/61	244	Voltage difference before and after changing the pull-up resistance in the sensor signal input circuit is 0.3 V or more (poor connection).	<ul style="list-style-type: none"> Brake actuator assembly Skid control ECU Harness and connector

WIRING DIAGRAM

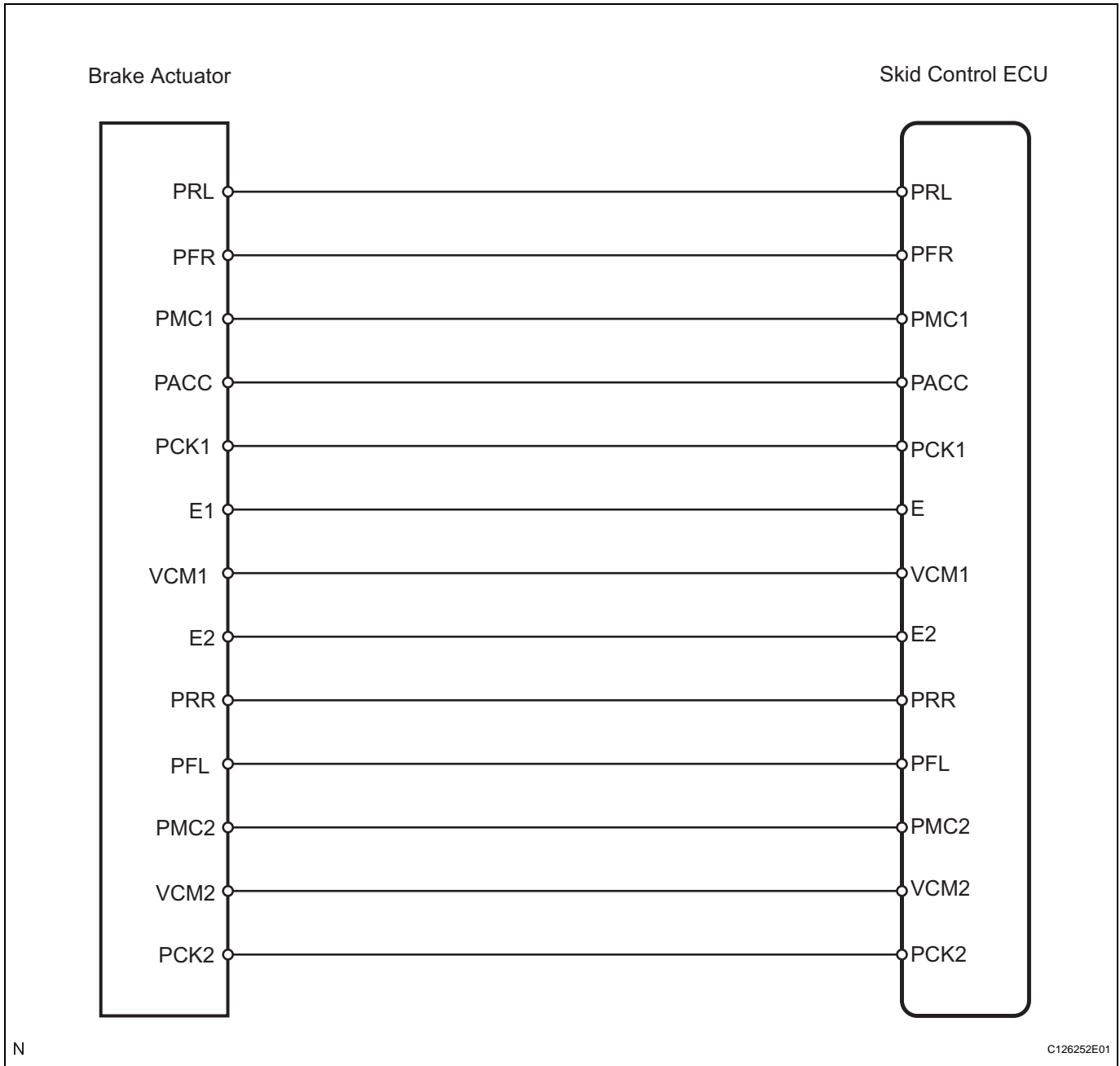

INSPECTION PROCEDURE

NOTICE:

When replacing the skid control ECU, perform initialization of linear solenoid valve and calibration (see page BC-19).



1 CHECK WIRE HARNESS (SKID CONTROL ECU - BRAKE ACTUATOR)

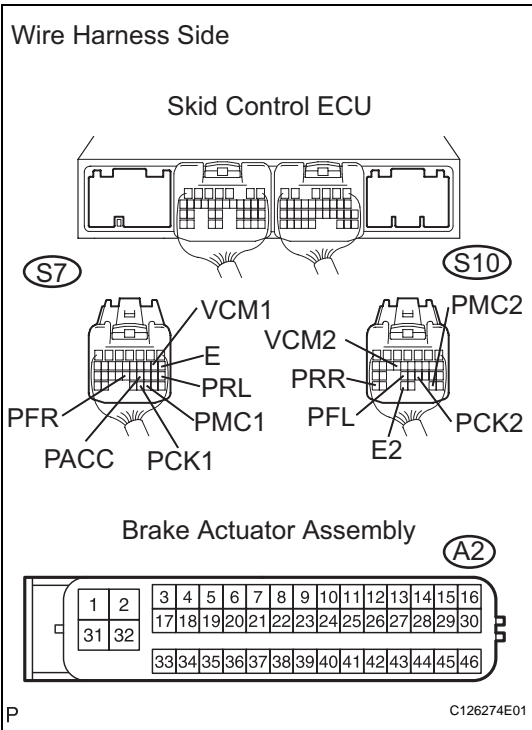

- (a) Disconnect the S7 and S10 ECU connectors.
- (b) Disconnect the A2 actuator connector.
- (c) Measure the resistance of the wire harness side connectors.

Standard resistance

Tester Connection	Specified Condition
S7-8 (E) - A2-45 (E1)	Below 1 Ω
S7-9 (VCM1) - A2-35 (VCM1)	Below 1 Ω
S7-18 (PRL) - A2-36 (PRL)	Below 1 Ω
S7-21 (PACC) - A2-46 (PACC)	Below 1 Ω
S7-23 (PFR) - A2-34 (PFR)	Below 1 Ω
S7-30 (PMC1) - A2-38 (PMC1)	Below 1 Ω
S7-31 (PCK1) - A2-37 (PCK1)	Below 1 Ω
S10-14 (VCM2) - A2-40 (VCM2)	Below 1 Ω
S10-21 (PCK2) - A2-42 (PCK2)	Below 1 Ω
S10-23 (PFL) - A2-39 (PFL)	Below 1 Ω
S10-27 (PMC2) - A2-43 (PMC2)	Below 1 Ω
S10-29 (E2) - A2-44 (E2)	Below 1 Ω
S10-31 (PRR) - A2-41 (PRR)	Below 1 Ω
S7-8 (E) - Body ground	10 kΩ or higher
S7-9 (VCM1) - Body ground	10 kΩ or higher
S7-18 (PRL) - Body ground	10 kΩ or higher
S7-21 (PACC) - Body ground	10 kΩ or higher
S7-23 (PFR) - Body ground	10 kΩ or higher
S7-30 (PMC1) - Body ground	10 kΩ or higher
S7-31 (PCK1) - Body ground	10 kΩ or higher
S10-14 (VCM2) - Body ground	10 kΩ or higher
S10-21 (PCK2) - Body ground	10 kΩ or higher
S10-27 (PMC2) - Body ground	10 kΩ or higher
S10-29 (E2) - Body ground	10 kΩ or higher
S10-31 (PRR) - Body ground	10 kΩ or higher

NG REPAIR OR REPLACE HARNESS AND CONNECTOR

OK

2 CHECK SKID CONTROL ECU

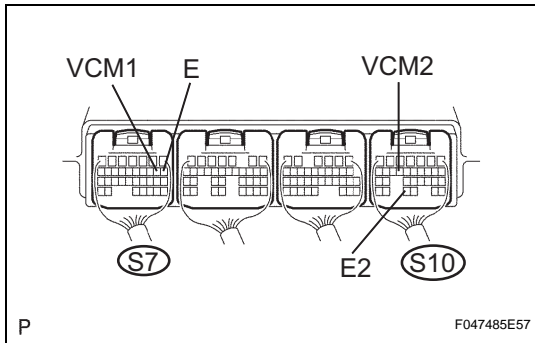

(a) Measure the voltage of the connectors.

HINT:

Measure the voltage from behind the connector with the connector connected to the skid control ECU.

Standard voltage

Tester Connection	Condition	Specified Condition
S7-9 (VCM1) - Body ground	Power switch ON (READY)	4.75 to 5.25 V
S10-14 (VCM2) - Body ground	Power switch ON (READY)	4.75 to 5.25 V

(b) Measure the resistance of the connectors.

Standard resistance

Tester Connection	Specified Condition
S7-8 (E) - Body ground	Below 1 Ω
S10-29 (E2) - Body ground	Below 1 Ω

NG → **REPLACE SKID CONTROL ECU**

OK

3 READ VALUE OF INTELLIGENT TESTER (MASTER CYLINDER PRESSURE SENSOR)

(a) Check the DATA LIST for proper functioning of the master cylinder pressure sensor.

Skid control ECU

Item	Measurement Item / Range (Display)	Normal Condition	Diagnostic Note
MAS CYL PRS 1	Master cylinder pressure sensor 1 reading / Min.: 0 V, Max.: 5 V	When brake pedal is released: 0.3 to 0.9 V	Reading increases when brake pedal is depressed
MAS CYL PRS 2	Master cylinder pressure sensor 2 reading / Min.: 0 V, Max.: 5 V	When brake pedal is released: 0.3 to 0.9 V	Reading increases when brake pedal is depressed

OK:

When the pedal is depressed, displayed voltage on the intelligent tester increase.

NG → **REPLACE BRAKE ACTUATOR ASSEMBLY**

OK

BC

4 READ VALUE OF INTELLIGENT TESTER (WHEEL CYLINDER PRESSURE SENSOR)

(a) Connect the pedal effort gauge.

(b) Install the LSPV gauge (SST) and bleed air (see page [BC-205](#)).

SST 09709-29018

(c) Select the DATA LIST mode on the intelligent tester.

Skid control ECU

Item	Measurement Item / Range (Display)	Normal Condition	Diagnostic Note
FR PRESS SENS	Front right pressure sensor / Min.: 0 V, Max.: 5 V	When brake pedal is released: 0.3 to 0.9 V	-
FL PRESS SENS	Front left pressure sensor / Min. 0 V, Max.: 5 V	When brake pedal is released: 0.3 to 0.9 V	-
RR PRESS SENS	Rear right pressure sensor / Min.: 0 V, Max.: 5 V	When brake pedal is released: 0.3 to 0.9 V	-
RL PRESS SENS	Rear left pressure sensor / Min. 0 V, Max.: 5 V	When brake pedal is released: 0.3 to 0.9 V	-

(d) Check the output value the wheel cylinder pressure sensor at each fluid pressure during the ECB control.

Standard voltage:

Front wheel cylinder pressure sensor

Fluid Pressure	FR PRESS SENS (DATA-LIST)	FL PRESS SENS (DATA-LIST)
1 MPa (10.2 kgf/cm ² , 145.0 psi)	0.65 to 0.75 V	0.65 to 0.75 V
3 MPa (30.6 kgf/cm ² , 435.2 psi)	1.05 to 1.2 V	1.05 to 1.2 V
7 MPa (71.4 kgf/cm ² , 1015.5 psi)	1.8 to 2.05 V	1.8 to 2.05 V
10 MPa (102.0 kgf/cm ² , 1450.7 psi)	2.4 to 2.7 V	2.4 to 2.7 V

Rear wheel cylinder pressure sensor

Fluid Pressure	RR PRESS SENS (DATA-LIST)	RL PRESS SENS (DATA-LIST)
1 MPa (10.2 kgf/cm ² , 145.0 psi)	0.65 to 0.75 V	0.65 to 0.75 V
3 MPa (30.6 kgf/cm ² , 435.2 psi)	1.05 to 1.2 V	1.05 to 1.2 V

NG **REPLACE BRAKE ACTUATOR ASSEMBLY**

OK

REPLACE SKID CONTROL ECU

DTC	C1247/47	Stroke Sensor Malfunction
------------	-----------------	----------------------------------

DTC	C1392/48	Stroke Sensor Zero Point Calibration Undone
------------	-----------------	--

DESCRIPTION

The stroke sensor inputs the pedal stroke into the skid control ECU.

DTC No.	INF Code	DTC Detection Condition	Trouble Area
C1247/47	171	Sensor power source voltage (VCSK) is 3.6 V or less or 4.95 V or more for at least 1.2 sec.	<ul style="list-style-type: none"> Brake pedal stroke sensor Skid control ECU Harness and connector
C1247/47	172	Ratio of sensor output voltage 1 (SKS1) to sensor power source voltage (VCSK) is less than 3% or 97% or more for at least 1.2 sec.	<ul style="list-style-type: none"> Brake pedal stroke sensor Skid control ECU Harness and connector
C1247/47	173	Ratio of sensor output voltage 2 (SKS2) to sensor power source voltage (VCSK) is less than 3% or 97% or more for at least 1.2 sec.	<ul style="list-style-type: none"> Brake pedal stroke sensor Skid control ECU Harness and connector
C1247/47	174	Sensor output 1 (SKS1) calculation value becomes 20 mm or more for at least 1.2 sec. at an interval of 0.006 sec. (changes due to interference).	<ul style="list-style-type: none"> Brake pedal stroke sensor Skid control ECU Harness and connector
C1247/47	175	Sensor output 2 (SKS2) calculation value becomes 20 mm or more for at least 1.2 sec. at an interval of 0.006 sec. (changes due to interference).	<ul style="list-style-type: none"> Brake pedal stroke sensor Skid control ECU Harness and connector
C1247/47	176	Zero point stored value (ratio to power source voltage) of sensor output 1 (SKS1) is 0.46 or more or 0.03 or less.	<ul style="list-style-type: none"> Brake pedal stroke sensor Skid control ECU Harness and connector
C1247/47	177	Zero point stored value (ratio to power source voltage) of sensor output 2 (SKS2) is 0.97 or more or 0.48 or less.	<ul style="list-style-type: none"> Brake pedal stroke sensor Skid control ECU Harness and connector
C1247/47	179	When either condition below is met: <ul style="list-style-type: none"> Sum of SKS1/VCSK and SKS2/VCSK is 1.155 or more or 0.845 or less for at least 1 sec. Difference between sensor output 1 (SKS1) and sensor output 2 (SKS2) is excessively large for at least 0.2 sec. 	<ul style="list-style-type: none"> Brake pedal stroke sensor Skid control ECU Harness and connector
C1247/47	180	When either condition below is met: <ul style="list-style-type: none"> Difference between zero point output value and stored value is 0.5 or more for at least 0.05 sec. Short between SKS1 and SKS2 output line. 	<ul style="list-style-type: none"> Brake pedal stroke sensor Skid control ECU Harness and connector
C1392/48	178	Zero point calibration of stroke sensor is unfinished.	<ul style="list-style-type: none"> Brake pedal stroke sensor zero point calibration undone (initialization of linear solenoid valve and calibration undone) Skid control ECU

WIRING DIAGRAM

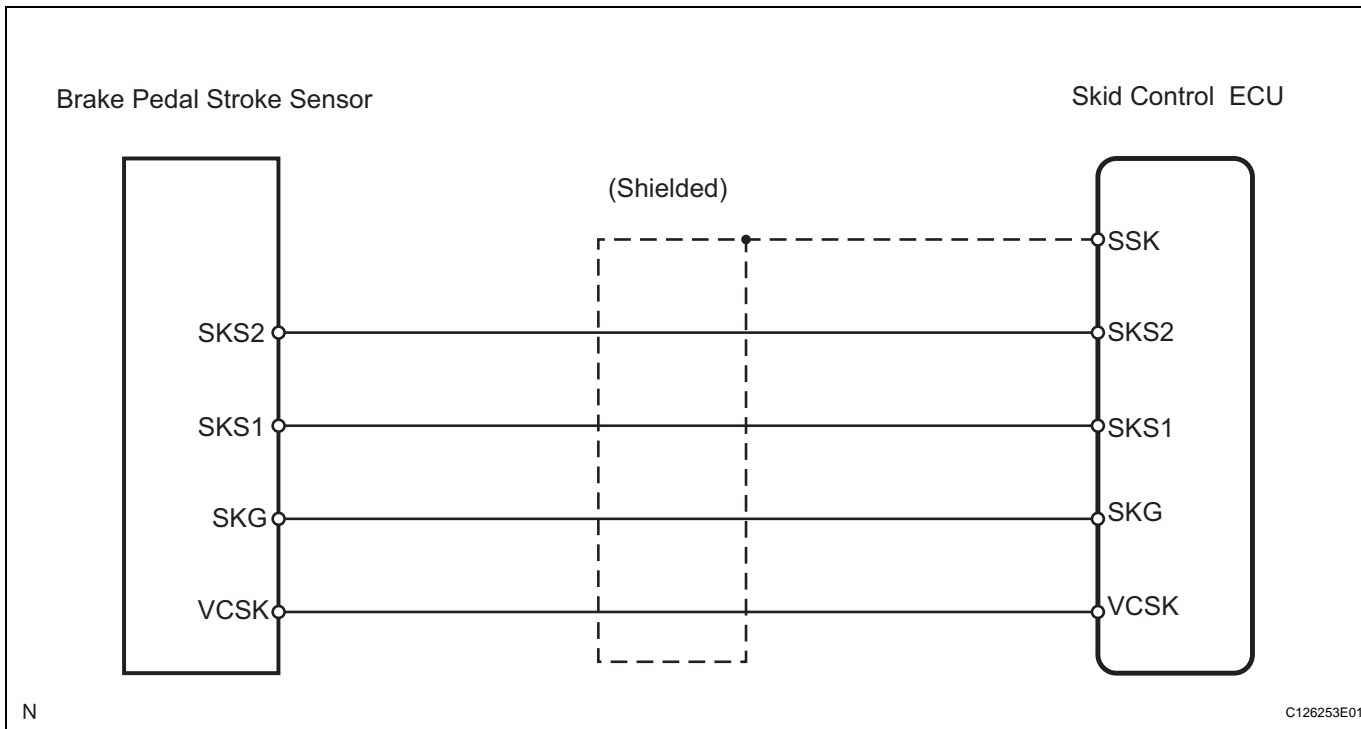

INSPECTION PROCEDURE

NOTICE:

When replacing the skid control ECU, perform initialization of linear solenoid valve and calibration (see page [BC-19](#)).

1 CHECK BRAKE PEDAL

- (a) Check that the brake pedal and the brake pedal stroke sensor are properly installed and that the pedal can be operated normally.
- (b) Check the brake pedal height.

OK:

The brake pedal is securely installed.
The pedal height is within the specified range (see page [BR-22](#)).

NG → **ADJUST BRAKE PEDAL**

OK

BC

2 READ VALUE OF INTELLIGENT TESTER (PEDAL STROKE SENSOR)

- (a) Turn the power switch ON (READY).

- (b) Check the DATA LIST for the proper functioning of the pedal stroke sensor.

Skid control ECU

Item	Measurement Item / Range (Display)	Normal condition	Diagnostic Note
PEDAL STROKE	Stroke sensor / Min.: 0 V, Max.: 5 V	When brake pedal is released: 0.7 to 1.3 V	-
PEDAL STROKE 2	Stroke sensor 2 / Min.: 0 V, Max.: 5 V	When brake pedal is released: 3.7 to 4.3 V	-

OK:

The normal condition value displayed on the intelligent tester.

NG

ADJUST BRAKE PEDAL STROKE SENSOR

OK

3

PERFORM INITIALIZATION OF LINEAR SOLENOID VALVE AND CALIBRATION

NEXT

4

RECONFIRM DTC

- (a) Clear the DTCs (see page [BC-38](#)).
 (b) Turn the power switch ON (READY).
 (c) Check the same DTCs are recorded (see page [BC-38](#)).

Result

Result	Proceed to
DTC is output	A
DTC is not output.	B

HINT:

This DTC may be memorized due to a malfunction in the connector terminal connection, etc.

B

END

A

5 CHECK WIRE HARNESS (SKID CONTROL ECU - BRAKE PEDAL STROKE SENSOR)

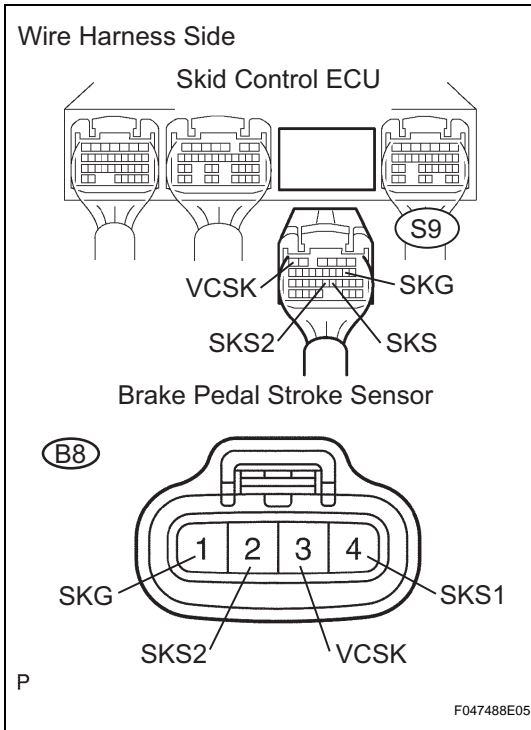

- (a) Disconnect the S9 ECU connector.
- (b) Disconnect the B8 sensor connector.
- (c) Measure the resistance of the wire harness side connectors.

Standard resistance

Tester Connection	Specified Condition
S9-6 (VCSK) - B8-3 (VCSK)	Below 1 Ω
S9-8 (SKG) - B8-1 (SKG)	Below 1 Ω
S9-21 (SKS1) - B8-4 (SKS1)	Below 1 Ω
S9-22 (SKS2) - B8-2 (SKS2)	Below 1 Ω
S9-6 (VCSK) - Body ground	10 kΩ or higher
S9-8 (SKG) - Body ground	10 kΩ or higher
S9-21 (SKS1) - Body ground	10 kΩ or higher
S9-22 (SKS2) - Body ground	10 kΩ or higher

NG → **REPAIR OR REPLACE HARNESS AND CONNECTOR**

OK

6 CHECK SKID CONTROL ECU (VCSK, SKG VOLTAGE)

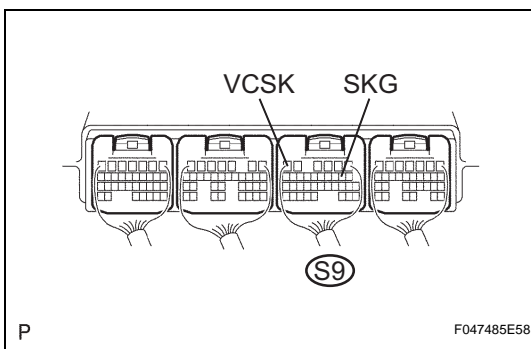

- (a) Measure the voltage of the connector.
- HINT:
Measure the voltage from behind the connector with the connector connected to the skid control ECU.

Standard voltage

Tester Connection	Specified Condition
S9-6 (VCSK) - S9-8 (SKG)	3.6 to 4.95 V

NG → **REPLACE SKID CONTROL ECU**

OK

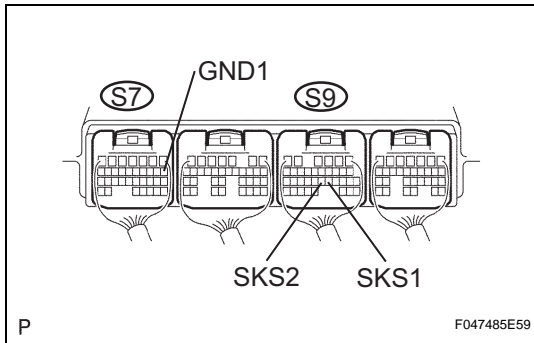
7 CHECK SKID CONTROL ECU (SKS1, SKS2 VOLTAGE)

(a) Measure the voltage of the connectors.

HINT:

- Measure the voltage from behind the connector with the connector connected to the skid control ECU.
- Slowly depress the brake pedal and check if the voltage between the skid control ECU terminals change in accordance with the pedal operation.

Standard voltage

Tester Connection	Specified Condition
S9-21 (SKS1) - S7-1 (GND1)	1.8 to 3.1 V
S9-22 (SKS2) - S7-1 (GND1)	1.8 to 3.1 V

NG

REPLACE BRAKE PEDAL STROKE SENSOR

OK

REPLACE SKID CONTROL ECU

DTC**C1249/49****Open in Stop Light Switch Circuit****DESCRIPTION**

The skid control ECU inputs the stop light switch signal and detects braking condition.

The skid control ECU has a circuit for open detection inside. The skid control ECU outputs the DTC if it detects an open in the stop light signal input line when the stop light switch is off, or an open in the stop light circuit (GND side).

DTC No.	INF Code	DTC Detection Condition	Trouble Area
C1249/49	520	Stop light switch circuit is open for at least 10 sec. when IG1 terminal voltage is between 9.5 V and 17.02 V	<ul style="list-style-type: none">• Stop light switch• Stop light switch circuit• Stop light bulb

WIRING DIAGRAM

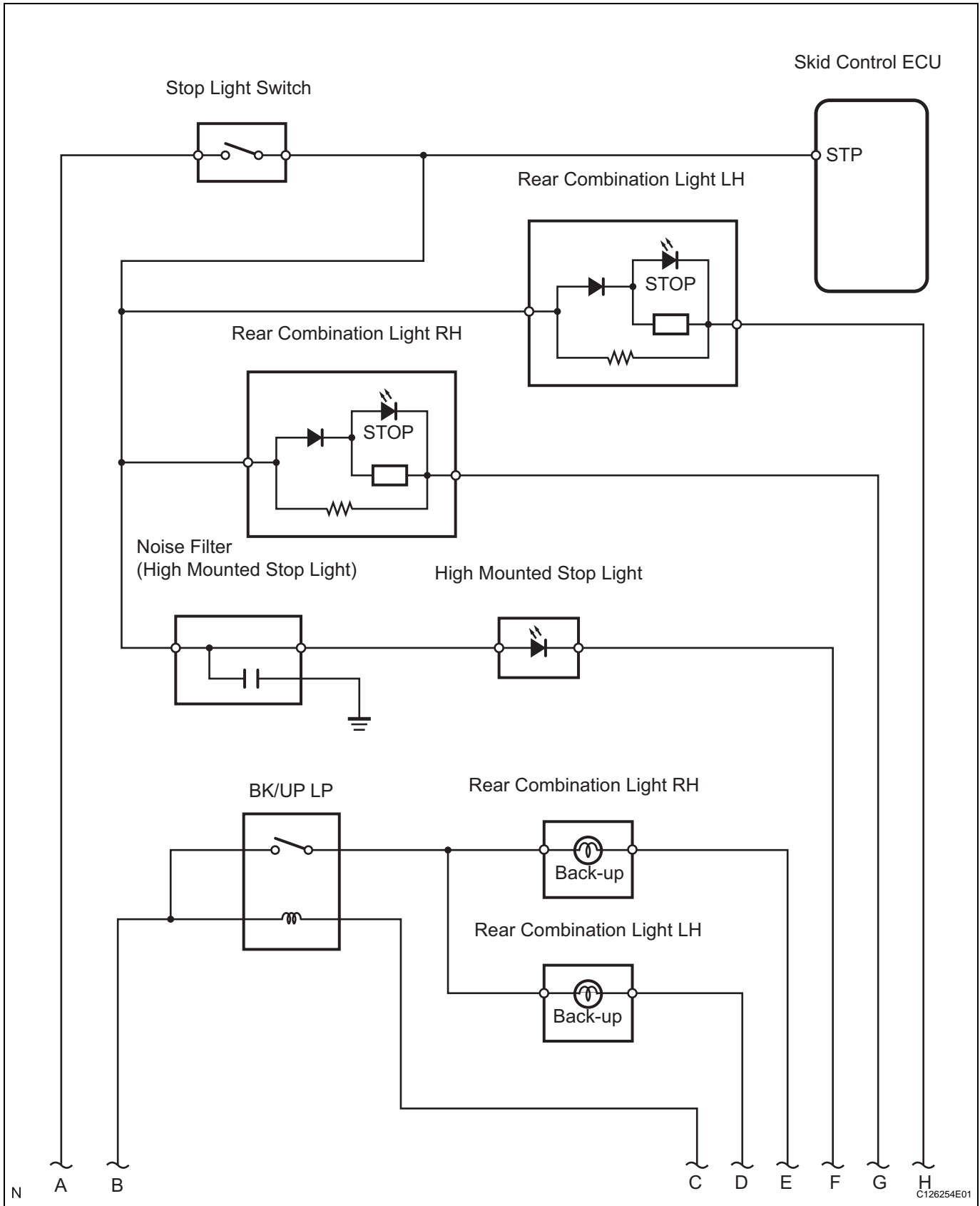

BC

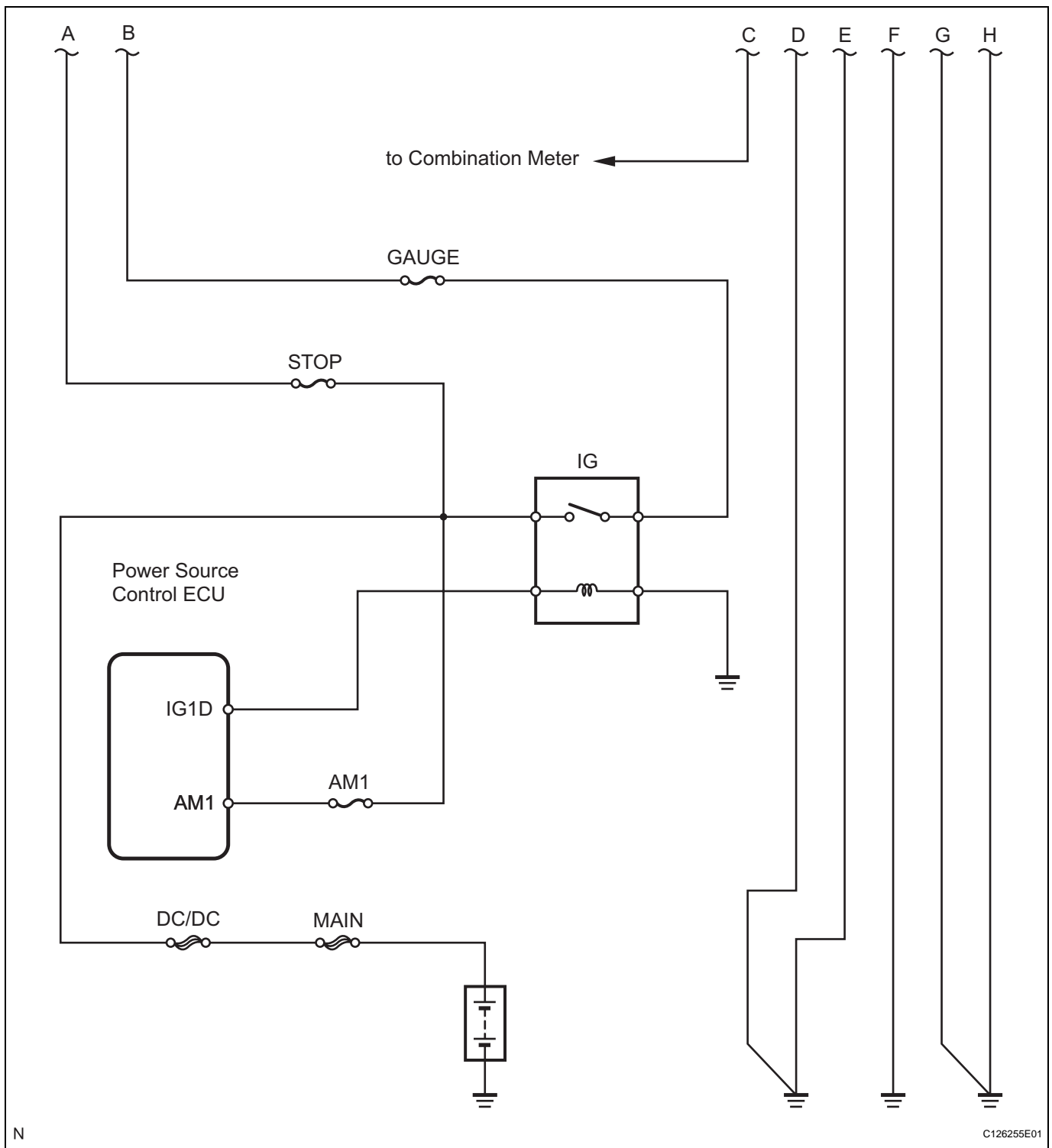

N

C126255E01

BC

INSPECTION PROCEDURE

NOTICE:

When replacing the skid control ECU, perform initialization of linear solenoid valve and calibration (see page [BC-19](#)).

1 CHECK STOP LIGHT SWITCH OPERATION

- (a) Check that the stop light comes on when the brake pedal is depressed and turns off when the brake pedal is released.

OK

Pedal Condition	Stop Light Condition
Brake pedal depressed	Turns on
Brake pedal released	Turns off

HINT:

Check the stop light bulb as it may have burnt out.

NG → **Go to step 4**

OK

2 CHECK SKID CONTROL ECU (STP VOLTAGE)

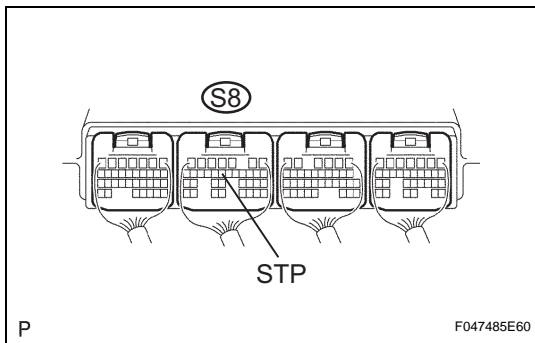

- (a) Measure the voltage of the connector.

HINT:

Measure the voltage from behind the connector with the connector connected to the skid control ECU.

Standard voltage

Tester Connection	Switch Condition	Specified Condition
S8-14 (STP) - Body ground	Brake pedal depressed	8 to 14 V
S8-14 (STP) - Body ground	Brake pedal released	Below 1 V

NG → **Go to step 5**

OK

3 RECONFIRM DTC

- (a) Clear the DTCs (see page BC-38).
- (b) Turn the power switch ON (READY).
- (c) Check the same DTCs are recorded (see page BC-38).

Result

Result	Proceed to
DTC is not output	A
DTC is output	B

B → **REPLACE SKID CONTROL ECU**

A

PROCEED TO NEXT CIRCUIT INSPECTION SHOWN IN PROBLEM SYMPTOMS TABLE

4 INSPECT STOP LIGHT SWITCH ASSEMBLY

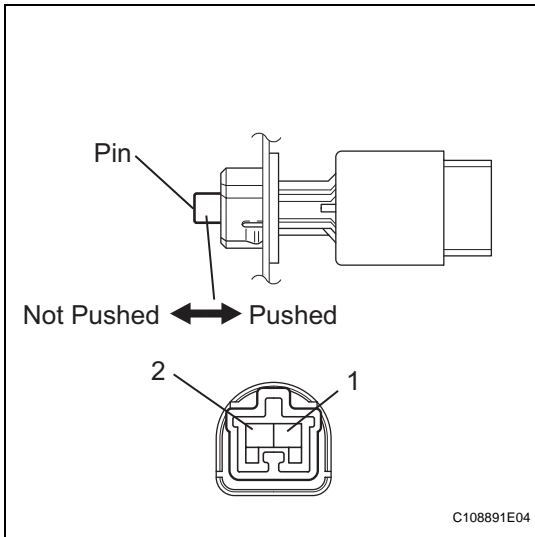

- (a) Disconnect the stop light switch connector.
- (b) Measure the resistance of the switch.

Standard resistance

Tester Connection	Switch Condition	Specified Condition
1 - 2	Switch pin not pushed	Below 1 Ω
1 - 2	Switch pin pushed	10 kΩ or higher

NG → **REPLACE STOP LIGHT SWITCH ASSEMBLY**

OK

5 CHECK WIRE HARNESS (SKID CONTROL ECU - STOP LIGHT SWITCH)

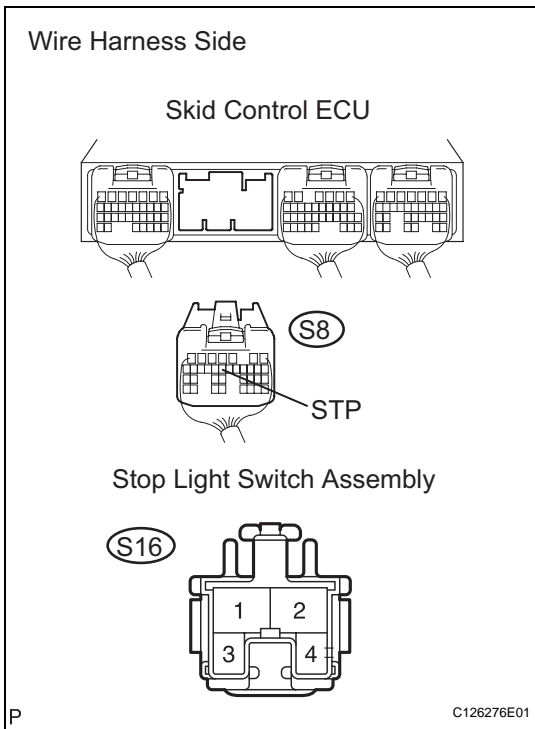

- (a) Disconnect the S8 ECU connector.
- (b) Disconnect the S16 switch connector.
- (c) Measure the resistance of the wire harness side connectors.

Standard resistance

Tester Connection	Specified Condition
S8-14 (STP) - S16-1	Below 1 Ω

NG → **REPAIR OR REPLACE HARNESS AND CONNECTOR**

OK

REPLACE SKID CONTROL ECU

DTC	C1252/52	Brake Booster Pump Motor on Time Abnormally Long
------------	-----------------	---

DTC	C1253/53	Hydro Booster Pump Motor Relay Malfunction
------------	-----------------	---

DESCRIPTION

The skid control ECU detects decreases in the accumulator pressure according to the data from the accumulator pressure sensor, and then starts and stops the pump motor by operating the motor relay. The skid control ECU usually drives the motor relay 1 (ABS HTR) for ECB control, and the motor relay 2 (ABS MTR 2) for ABS control. If either is malfunctioning, the other substitutes.

DTC No.	INF Code	DTC Detection Condition	Trouble Area
C1252/52	130	Motor relay is ON for at least 5 min.	Brake actuator assembly
C1253/53	132	Motor relay 1 coil (monitor) is energized for at least 1 sec. when main relay 1 monitor (BS1) is 9.5 V or more and motor relay 1 is off.	<ul style="list-style-type: none"> • ABS MTR relay • ABS MTR 2 relay • Harness and connector • Brake actuator assembly
C1253/53	133	Motor relay 1 coil (monitor) is not energized for at least 1 sec. when main relay 1 monitor (BS1) is 9.5 V or more and motor relay 1 is on.	<ul style="list-style-type: none"> • ABS MTR relay • ABS MTR 2 relay • Harness and connector • Brake actuator assembly
C1253/53	134	MTT input is 3.5 V or less for at least 0.2 sec. when main relay 1 monitor (BS1) is 9.5 V or more and motor relay 1 is on.	<ul style="list-style-type: none"> • ABS MTR relay • ABS MTR 2 relay • Harness and connector • Brake actuator assembly
C1253/53	136	Motor relay 2 coil (monitor) is energized for at least 1 sec. when main relay 2 monitor (BS2) is 9.5 V or more and motor relay 2 is off.	<ul style="list-style-type: none"> • ABS MTR relay • ABS MTR 2 relay • Harness and connector • Brake actuator assembly
C1253/53	137	Motor relay 2 coil (monitor) is not energized for at least 1 sec. (0.2 sec. during initial check) when main relay 2 monitor (BS2) is 9.5 V or more and motor relay 2 is on.	<ul style="list-style-type: none"> • ABS MTR relay • ABS MTR 2 relay • Harness and connector • Brake actuator assembly
C1253/53	138	MTT input is 3.5 V or less for at least 1 sec. (0.2 sec. during initial check) when main relay 1 monitor (BS1) is 9.5 V or more and motor relay 2 is on.	<ul style="list-style-type: none"> • ABS MTR relay • ABS MTR 2 relay • Harness and connector • Brake actuator assembly
C1253/53	140	MTT input is 3.5 V or more for at least 2 sec. when motor relay 1 and 2 are off.	<ul style="list-style-type: none"> • ABS MTR relay • ABS MTR 2 relay • Harness and connector • Brake actuator assembly

WIRING DIAGRAM

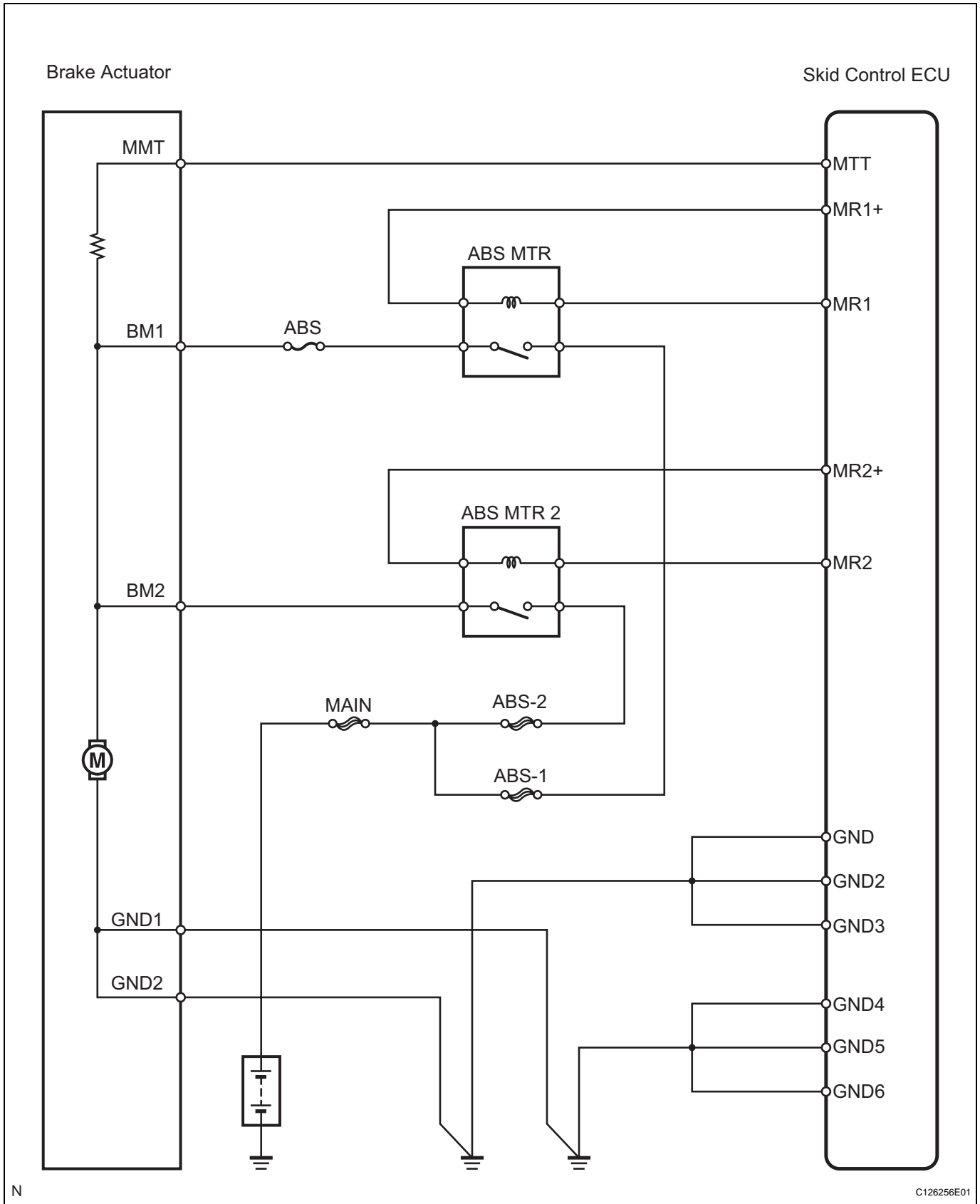

N

C126256E01

BC

INSPECTION PROCEDURE

NOTICE:

When replacing the skid control ECU, perform initialization of linear solenoid valve and calibration (see page BC-19).

1 PERFORM ACTIVE TEST BY INTELLIGENT TESTER (ABS MOTOR RELAY OPERATION)

- (a) Select the ACTIVE TEST, generate a control command, and then check that the ABS motor relay operates.

Skid control ECU

Item	Test Details	Diagnostic Note
MOTOR RELAY 1	Turns MOTOR RELAY 1 ON / OFF	Operation of solenoid (clicking sound) can be heard
MOTOR RELAY 2	Turns MOTOR RELAY 2 ON / OFF	Operation of solenoid (clicking sound) can be heard

OK:

The operation sound of the ABS motor should be heard.

NG

Go to step 6

OK

2 INSPECT FUSE (ABS-1, ABS-2)

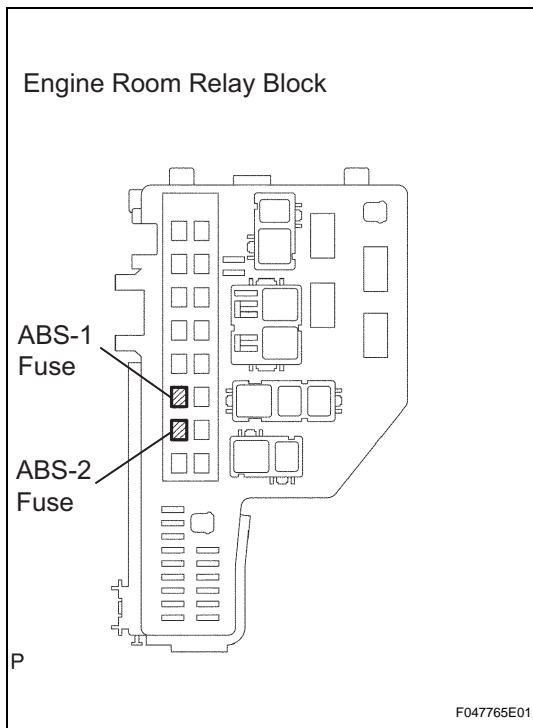

- (a) Remove the ABS-1 and ABS-2 fuses from the engine room relay block.
 (b) Measure the resistance of the fuses.

Standard resistance:

Below 1 Ω

NG

CHECK FOR SHORTS IN ALL HARNESS AND CONNECTOR CONNECTED TO FUSE AND REPLACE FUSE

OK

3 INSPECT BRAKE ACTUATOR ASSEMBLY

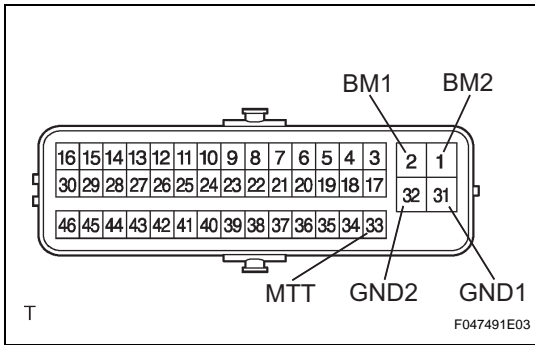

- (a) Disconnect the brake actuator connector.
- (b) Measure the resistance of the actuator.

Standard resistance

Tester Connection	Specified Condition
1 (BM2) - 31 (GND1)	Below 10 Ω
2 (BM1) - 31 (GND1)	Below 10 Ω
1 (BM2) - 2 (BM1)	Below 1 Ω
31 (GND1) - 32 (GND2)	Below 1 Ω
1 (BM2) - 33 (MTT)	About 33 Ω
2 (BM1) - 33 (MTT)	About 33 Ω

NG → **REPLACE BRAKE ACTUATOR ASSEMBLY**

OK

4 CHECK WIRE HARNESS (SKID CONTROL ECU - BRAKE ACTUATOR ASSEMBLY)

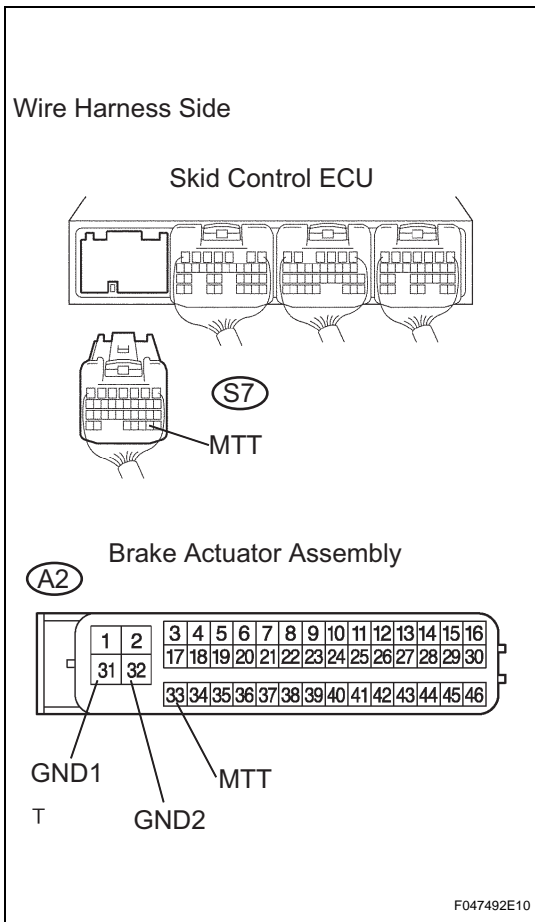

- (a) Disconnect the S7 ECU connector.
- (b) Disconnect the A2 actuator connector.
- (c) Measure the resistance of the wire harness side connectors.

Standard resistance

Tester Connection	Specified Condition
S7-29 (MTT) - A2-33 (MTT)	Below 1 Ω
A2-31 (GND1) - Body ground	Below 1 Ω
A2-32 (GND2) - Body ground	Below 1 Ω

NG → **REPAIR OR REPLACE HARNESS AND CONNECTOR**

OK

5 READ VALUE OF INTELLIGENT TESTER (ACCUMULATOR PRESSURE SENSOR)

- (a) Check the DATA LIST for proper functioning of the accumulator pressure sensor.
- (b) Depress the brake pedal 4 or 5 times to operate the pump motor, and check the output value on the intelligent tester with the motor stopped (not braking).

Skid control ECU

Item	Measurement Item / Range (Display)	Normal Condition	Diagnostic Note
ACC PRESS SENS 1	Accumulator pressure sensor 1 / Min.: 0 V, Max.: 5 V	Specified value: 3.2 to 4.0 V	-

OK:
Accumulator pressure sensor voltage does not drop.

NG → **REPLACE BRAKE ACTUATOR ASSEMBLY**

OK

REPLACE SKID CONTROL ECU

6 INSPECT RELAY (Marking: ABS MTR, ABS MTR 2)

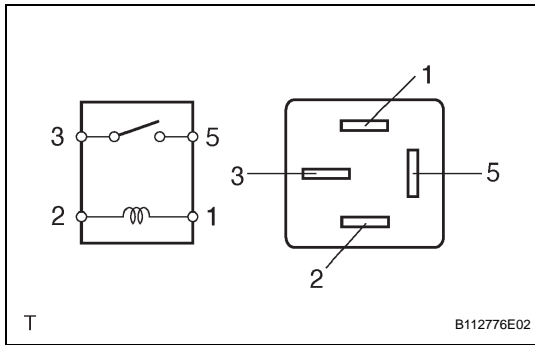

- (a) Remove the ABS MTR and ABS MTR 2 relays from the engine room relay block.
- (b) Measure the resistance of the relays.
Standard resistance

Tester Connection	Specified Condition
3 - 5	10 kΩ or higher
3 - 5	Below 1 Ω (when battery voltage is applied to terminals 1 and 2)

NG → **REPLACE RELAY**

OK

7 CHECK WIRE HARNESS (ENGINE ROOM RELAY BLOCK - BATTERY)

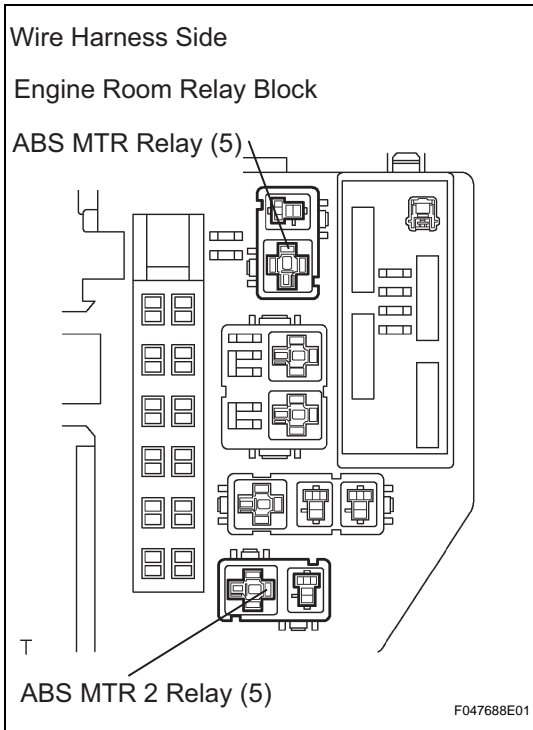

- (a) Remove the ABS MTR and MTR 2 relays from the engine room relay block.
- (b) Measure the voltage of the wire harness side connectors.

Standard voltage

Tester Connection	Specified Condition
ABS MTR relay terminal 5 - Body ground	10 to 14 V
ABS MTR 2 relay terminal 5 - Body ground	10 to 14 V

NG REPAIR OR REPLACE HARNESS AND CONNECTOR

OK

8 CHECK WIRE HARNESS (ENGINE ROOM RELAY BLOCK - BRAKE ACTUATOR)

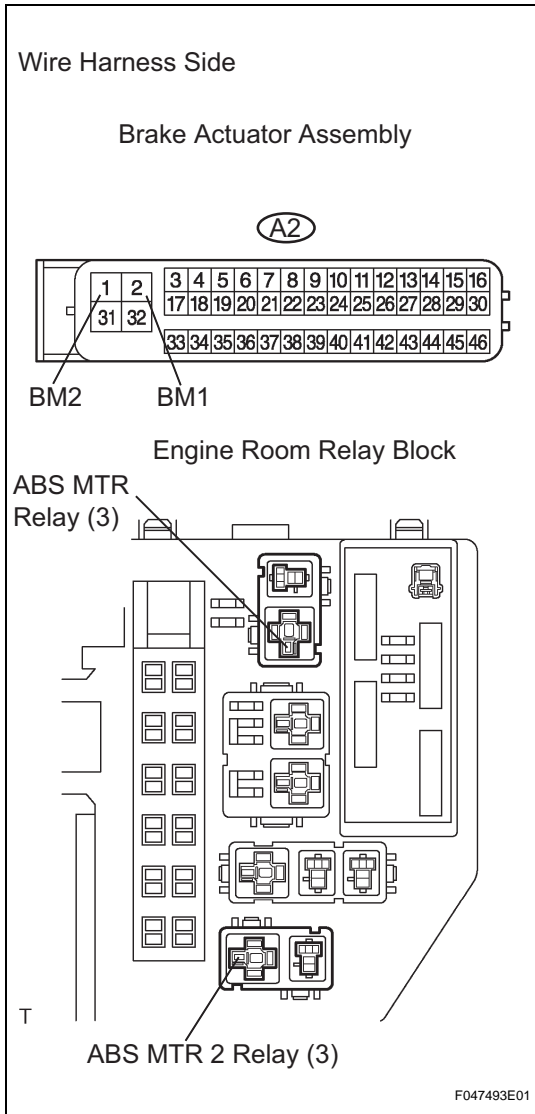

- (a) Disconnect the A2 actuator connector.
- (b) Remove the ABS MTR and ABS MTR 2 relays from the engine room relay block.
- (c) Measure the resistance of the wire harness side connectors.

Standard resistance

Tester Connection	Specified Condition
A2-1 (BM2) - ABS MTR 2 relay terminal 3	Below 1 Ω
A2-2 (BM1) - ABS MTR relay terminal 3	Below 1 Ω
A2-1 (BM2) - Body ground	10 kΩ or higher
A2-2 (BM1) - Body ground	10 kΩ or higher

NG **REPAIR OR REPLACE HARNESS AND CONNECTOR**

OK

9 CHECK WIRE HARNESS (ENGINE ROOM RELAY BLOCK - SKID CONTROL ECU)

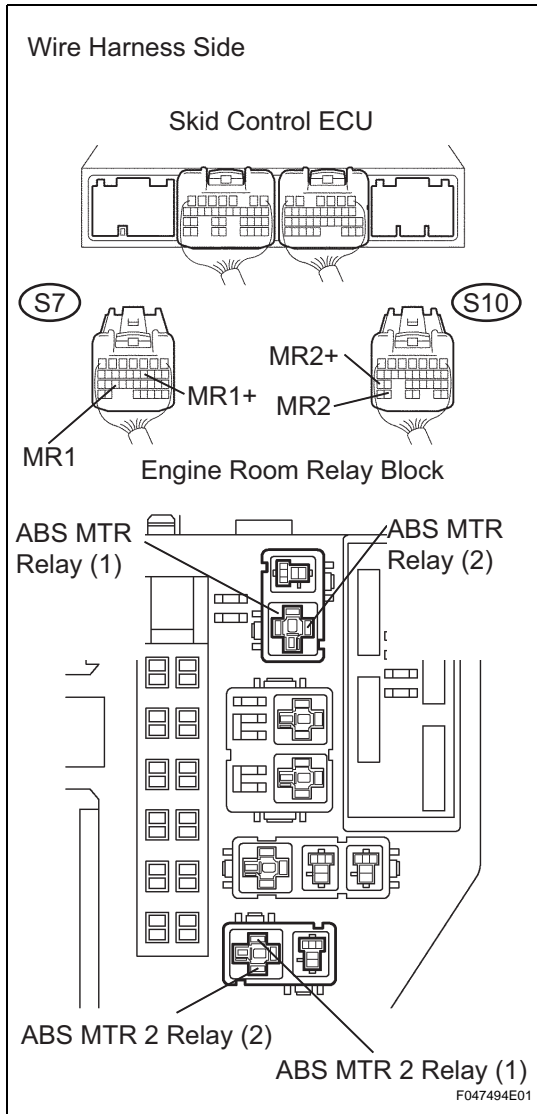

- (a) Disconnect the S7 and S10 ECU connectors.
- (b) Remove the ABS MTR and MTR 2 relays from the engine room relay block.
- (c) Measure the resistance of the wire harness side connectors.

Standard resistance

Tester Connection	Specified Condition
S7-11 (MR1+) - ABS MTR relay terminal 2	Below 1 Ω
S7-25 (MR1) - ABS MTR relay terminal 1	Below 1 Ω
S10-25 (MR2+) - ABS MTR 2 relay terminal 2	Below 1 Ω
S10-30 (MR2) - ABS MTR 2 relay terminal 1	Below 1 Ω
S7-11 (MR1+) - Body ground	10 kΩ or higher
S7-25 (MR1) - Body ground	10 kΩ or higher
S10-25 (MR2+) - Body ground	10 kΩ or higher
S10-30 (MR2) - Body ground	10 kΩ or higher

NG REPAIR OR REPLACE HARNESS AND CONNECTOR

OK

REPLACE SKID CONTROL ECU

DTC**C1256/57****Accumulator Low Pressure****DESCRIPTION**

The accumulator pressure sensor is built into the actuator and detects the accumulator pressure. The skid control ECU turns on the Brake Control warning light and sounds the skid control buzzer if it senses a decrease in the accumulator pressure.

DTC No.	INF Code	DTC Detection Condition	Trouble Area
C1256/57	141	When either condition below is met: <ul style="list-style-type: none"> Braking operation is input when accumulator pressure is less than 12.45 MPa and vehicle speed is input (detected value changes if accumulator pressure is low after system start). Accumulator pressure is less than 14.62 MPa for 120 sec. (changes according to power source voltage) after system start (stores the DTC after the conditions are met, and drives buzzer). 	Brake actuator assembly (accumulator pressure, accumulator pressure sensor, pump motor)
C1256/57	143	When one of following conditions is met: <ul style="list-style-type: none"> Any of the wheel cylinder pressure sensor value is lower than the target value for at least 0.5 sec. when accumulator pressure is less than 14.62 MPa and vehicle speed is input. Accumulator pressure changes little when accumulator pressure is less than 14.62 MPa for at least 1 sec. without braking (pump motor is operating). Accumulator pressure is less than 14.62 MPa for at least 0.5 sec. when motor relay is malfunctioning. 	Brake actuator assembly (accumulator pressure, accumulator pressure sensor, pump motor)

INSPECTION PROCEDURE**NOTICE:**

When replacing the skid control ECU, perform initialization of linear solenoid valve and calibration (see page [BC-19](#)).

HINT:**BC**

DTCs may be output if the accumulator pressure drops due to frequent braking (this is not a malfunction).

1 INSPECT BRAKE ACTUATOR ASSEMBLY

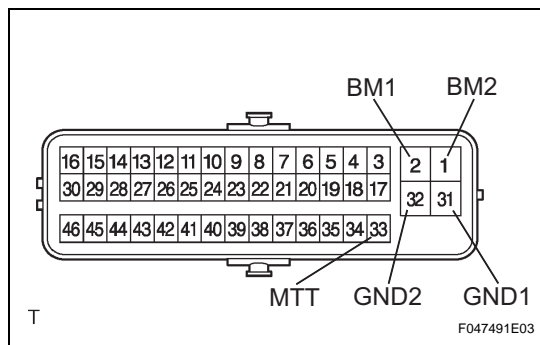

- (a) Disconnect the brake actuator connector.
- (b) Measure the resistance of the actuator.

Standard resistance

Tester Connection	Specified Condition
1 (BM2) - 31 (GND1)	Below 10 Ω
2 (BM1) - 31 (GND1)	Below 10 Ω
1 (BM2) - 2 (BM1)	Below 1 Ω
31 (GND1) - 32 (GND2)	Below 1 Ω
1 (BM2) - 33 (MTT)	Approx. 10 Ω
2 (BM1) - 33 (MTT)	Approx. 10 Ω

NG → **REPLACE BRAKE ACTUATOR ASSEMBLY**

OK

2 READ VALUE OF INTELLIGENT TESTER (ACCUMULATOR PRESSURE SENSOR)

- (a) Check the DATA LIST for proper functioning of the accumulator pressure sensor.
- (b) Depress the brake pedal 4 or 5 times to operate the pump motor, and check the output value on the intelligent tester with the motor stopped (not braking).

Skid control ECU

Item	Measurement Item / Range (Display)	Normal condition	Diagnostic Note
ACC PRESS SENS 1	Accumulator pressure sensor 1 / Min.: 0 V, Max.: 5 V	Specified value: 3.2 to 4.0 V	-

OK:
Accumulator pressure sensor's output voltage does not drop.

NG → **REPLACE BRAKE ACTUATOR ASSEMBLY**

OK

REPLACE SKID CONTROL ECU

DTC	C1259/58	HV System Regenerative Malfunction
DTC	C1310/51	Malfunction in HV system

DESCRIPTION

The skid control ECU communicates with the hybrid control ECU and controls braking force according to the motor's regenerative force.

The skid control ECU sends Enhanced VSC signal to the hybrid control ECU and inputs operating signal from the hybrid control ECU.

The skid control ECU uses CAN communication for communication with the hybrid control ECU. If a communication malfunction is memorized, the skid control ECU prohibits Enhanced VSC operation and a part of ECB control by fail-safe function.

C1259/59 is stored if the power switch is ON (READY) with the HV battery service plug disconnected.

DTC No.	INF Code	DTC Detection Condition	Trouble Area
C1259/58	150	The regeneration malfunction signal is input for at least 0.02 sec. when IG2 terminal voltage is 9.5 V or more for at least 2 sec. and communication with hybrid control ECU is valid.	Hybrid control system
C1310/51	156	The traction control prohibition signal is received for at least 0.07 sec. when IG2 terminal voltage is 10.5 V or more for at least 1.5 sec. and communication with hybrid control ECU is valid.	Hybrid control system (Enhanced VSC)

WIRING DIAGRAM

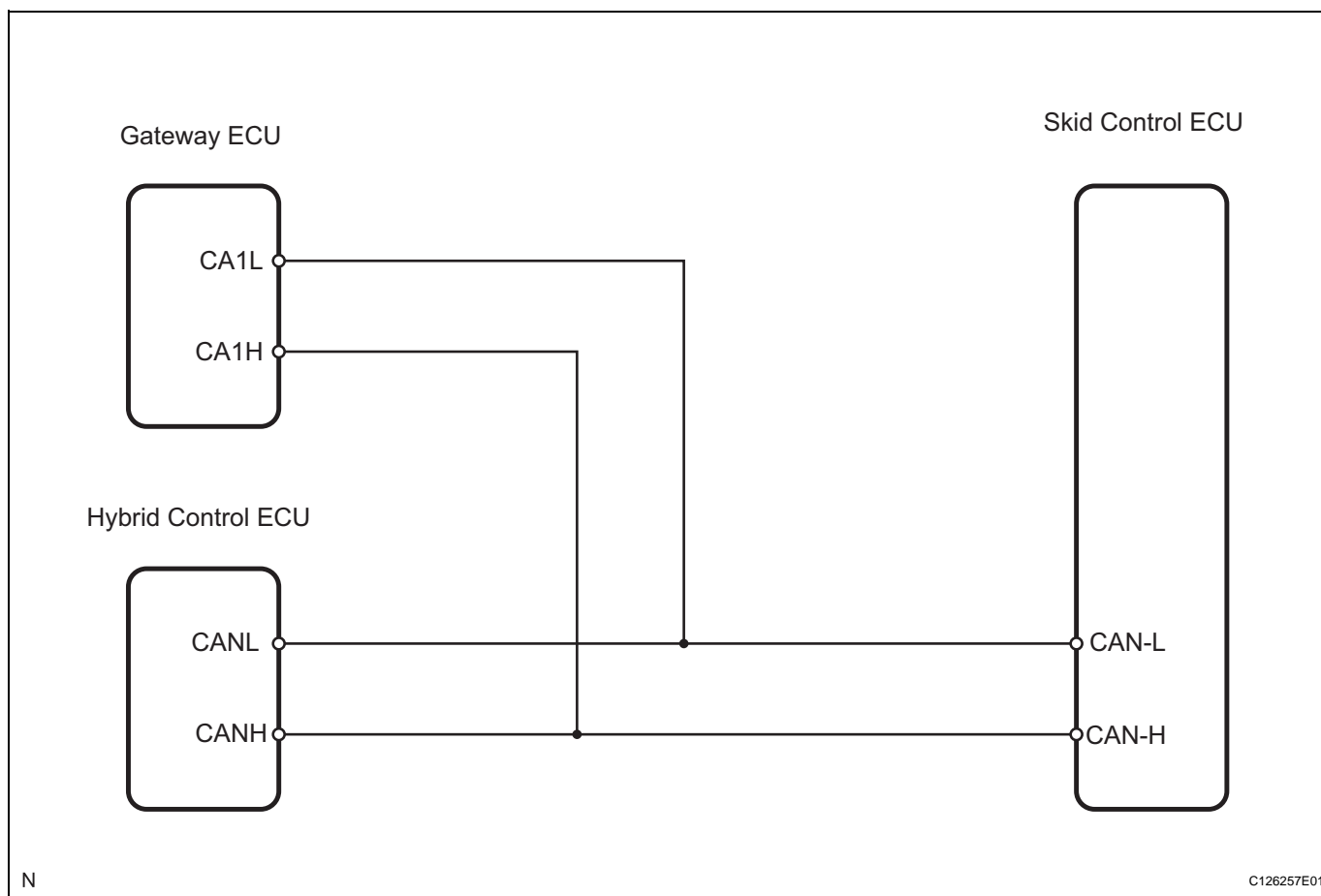

HINT:

This DTC is output from the skid control ECU when the hybrid control ECU sends a malfunction signal to the skid control ECU.

INSPECTION PROCEDURE

1	CHECK HYBRID CONTROL SYSTEM
----------	------------------------------------

(a) Check the hybrid control system (see page [HV-55](#)).

NEXT

END

DTC**C1300****Skid Control ECU Malfunction****DESCRIPTION**

The skid control ECU outputs this DTC if malfunctions are found in the circuit inside the computer by self-diagnosis.

DTC No.	INF Code	DTC Detecting Condition	Trouble Area
C1300/-	-	Malfunction in skid control ECU	Skid control ECU

INSPECTION PROCEDURE**NOTICE:**

When replacing the skid control ECU, perform initialization of linear solenoid valve and calibration (see page [BC-19](#)).

1**CHECK DTC**

- (a) Clear the DTCs (see page [BC-38](#)).
- (b) Turn the power switch ON (READY).
- (c) Check the same DTCs are recorded (see page [BC-38](#)).

Result

Result	Proceed to
DTC is output	A
DTC is not output	B

B

**PROCEED TO NEXT CIRCUIT INSPECTION
SHOWN IN PROBLEMS TABLE**

A**REPLACE SKID CONTROL ECU**

DTC	C1311/11	Open in Main Relay 1 Circuit
DTC	C1312/12	Short in Main Relay 1 Circuit
DTC	C1313/13	Open in Main Relay 2 Circuit
DTC	C1314/14	Short in Main Relay 2 Circuit

DESCRIPTION

ABS main relay 1 (ABS NO. 1 relay) supplies power to the changeover solenoid and the linear solenoid. ABS main relay 2 (ABS NO. 2 relay) goes on for approximately 5 seconds after the power switch is turned off and the braking effort signal input is terminated. ABS main relay 2 (ABS NO. 2 relay) supplies electricity and maintains operating condition for the brake system when the power switch is OFF.

DTC No.	INF Code	DTC Detection Condition	Trouble Area
C1311/11	1	When either condition below is met: <ul style="list-style-type: none"> Relay contact is off (BS 1 terminal is less than 3.5 V) for at least 0.2 sec. when R1+ terminal voltage is 9.5 V or more and main relay 1 is on. R1+ terminal voltage is less than 9.5 V and main relay 1 cannot be on for at least 0.2 sec. when main relay 1 is turned on (BS 1 terminal is 3.5 V or more). 	<ul style="list-style-type: none"> ABS main relay 1 (ABS NO. 1 relay) Skid control ECU Harness and connector
C1312/12	3	Relay contact is on for at least 4 sec. when main relay 1 is off.	<ul style="list-style-type: none"> ABS main relay 1 (ABS NO. 1 relay) Skid control ECU Harness and connector
C1313/13	4	When either condition below is met: <ul style="list-style-type: none"> Relay contact is off (BS2 terminal is less than 3.5 V) for at least 0.2 sec. when R2+ terminal voltage is 9.5 V or more and main relay 2 is on. R2+ terminal voltage is less than 9.5 V and main relay 2 cannot be on for at least 2 sec. when main relay 2 is turned on (BS 1 terminal is 3.5 V or more). 	<ul style="list-style-type: none"> ABS main relay 2 (ABS NO. 2 relay) Skid control ECU Harness and connector
C1314/14	6	Relay contact is on for at least 4 sec. when main relay 2 is off.	<ul style="list-style-type: none"> ABS main relay 2 (ABS NO. 2 relay) Skid control ECU Harness and connector

WIRING DIAGRAM

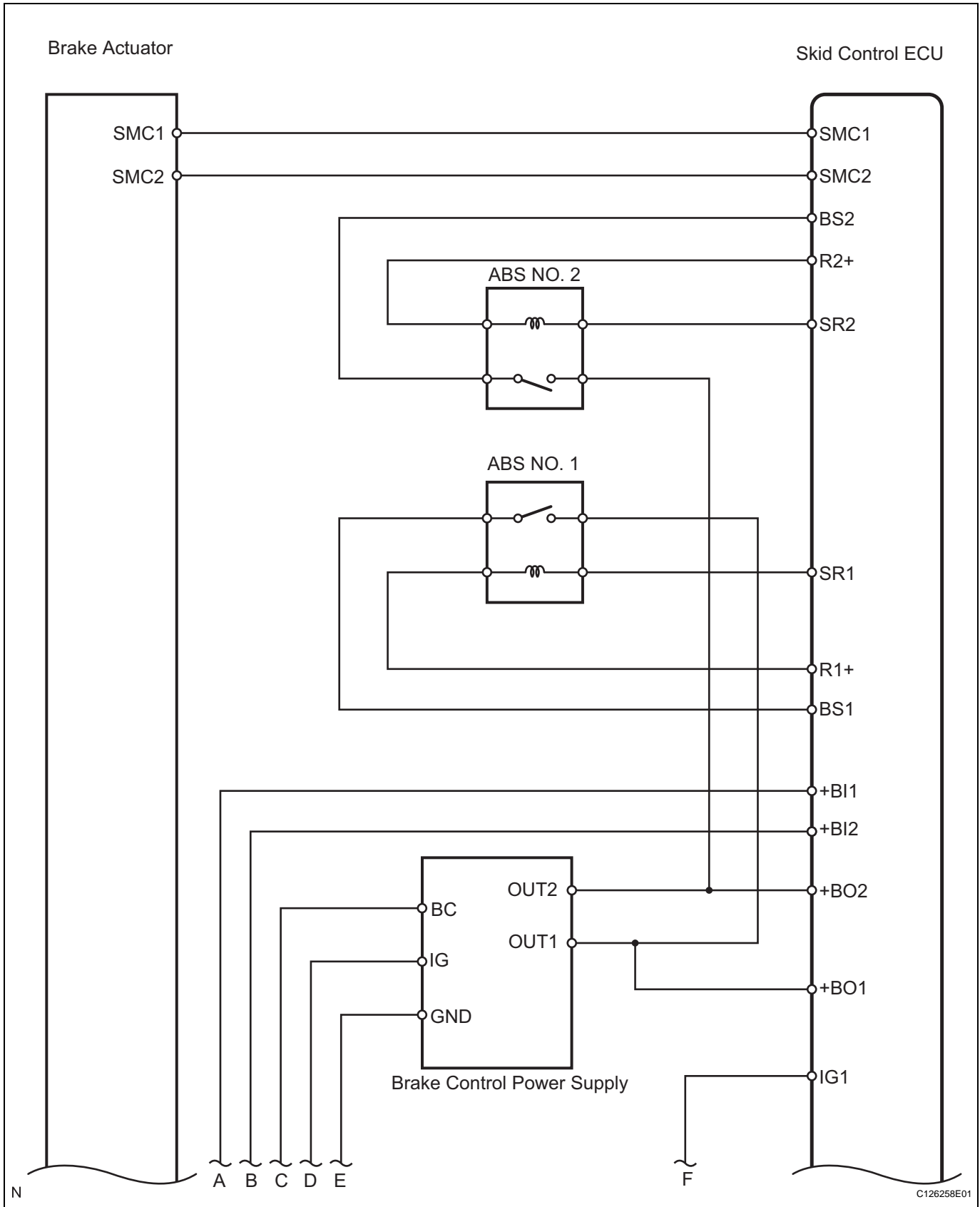

BC

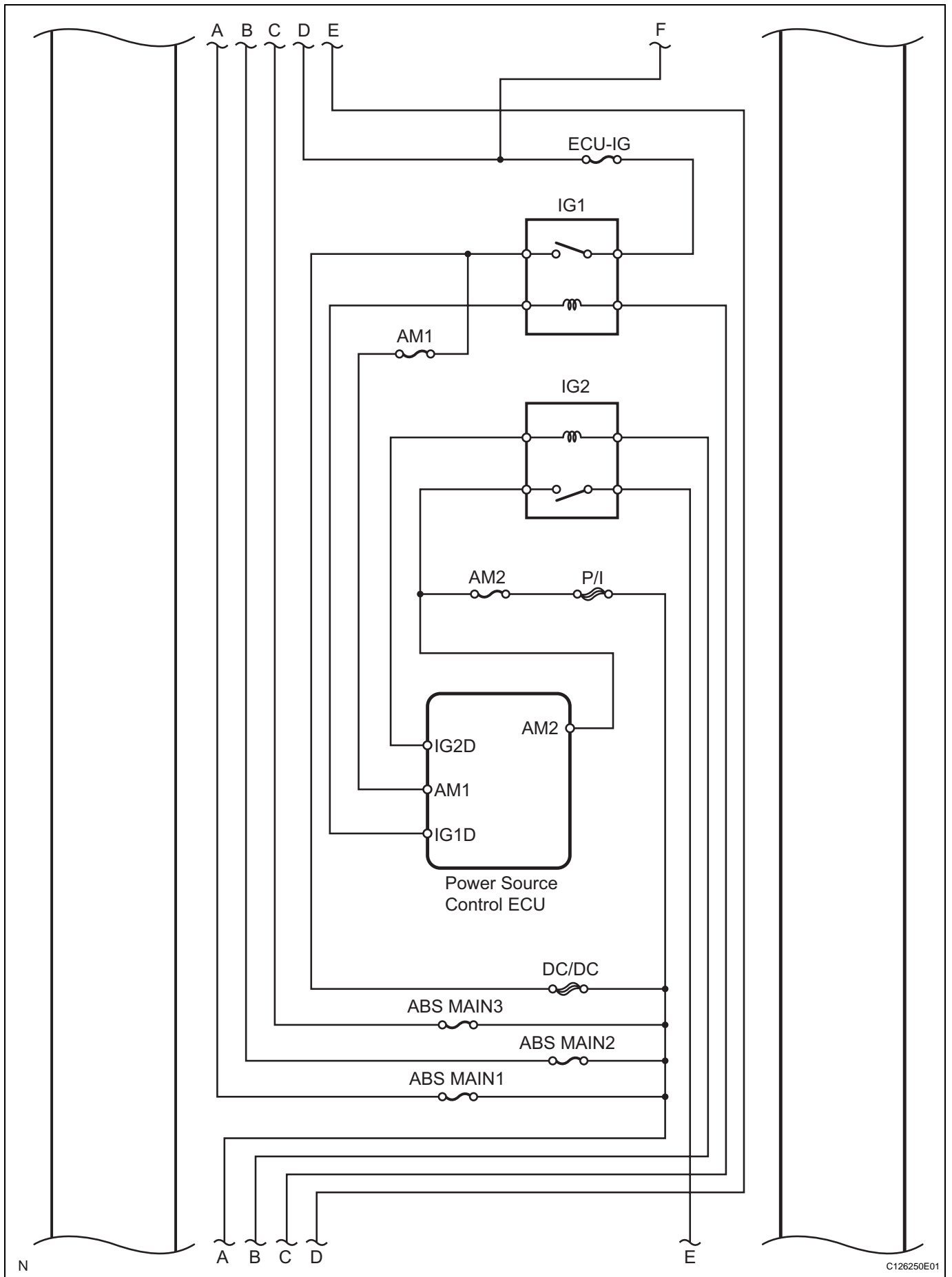

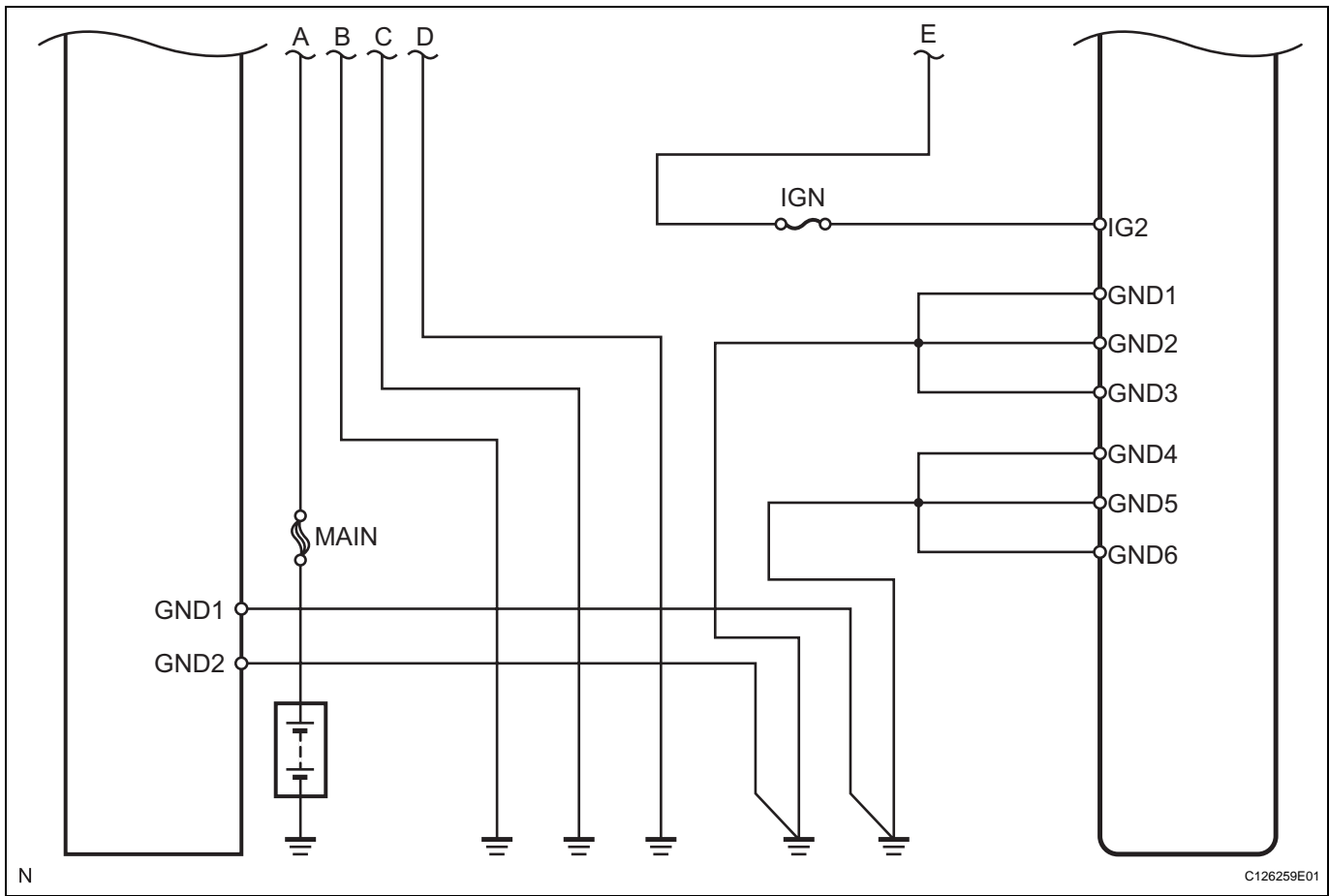

INSPECTION PROCEDURE

NOTICE:

When replacing the skid control ECU, perform initialization of linear solenoid valve and calibration (see page BC-19).

1	PERFORM ACTIVE TEST BY INTELLIGENT TESTER (ABS NO. 1 RELAY, ABS NO. 2 RELAY)
----------	---

(a) Select the ACTIVE TEST for the proper functioning of the ABS NO. 1 and ABS NO. 2 relays.

Skid control ECU

Item	Test Details	Diagnostic Note
MAIN RELAY 2	Turns MAIN RELAY 1 ON / OFF	Operation of solenoid (clicking sound) can be heard
MAIN RELAY 1	Turns MAIN RELAY 2 ON / OFF	Operation of solenoid (clicking sound) can be heard

OK:

Operation sound of ABS NO. 1 relay and ABS NO. 2 relay should be heard.

NG
Go to step 3

OK

2 CHECK SKID CONTROL ECU (BS1, BS2 VOLTAGE)

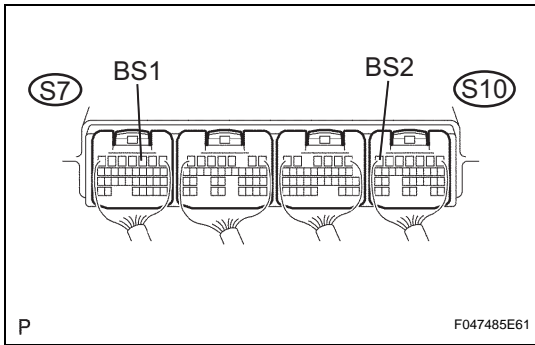

- (a) Measure the voltage of the connectors.
 HINT:
 Measure the voltage from behind the connector with the connector connected to the skid control ECU.

Standard voltage

Tester Connection	Specified Condition
S7-3 (BS1) - Body ground	10 to 14 V
S10-7 (BS2) - Body ground	10 to 14 V

NG → **REPAIR OR REPLACE HARNESS AND CONNECTOR**

OK

REPLACE SKID CONTROL ECU

3 INSPECT FUSE (ABS MAIN1, ABS MAIN2)

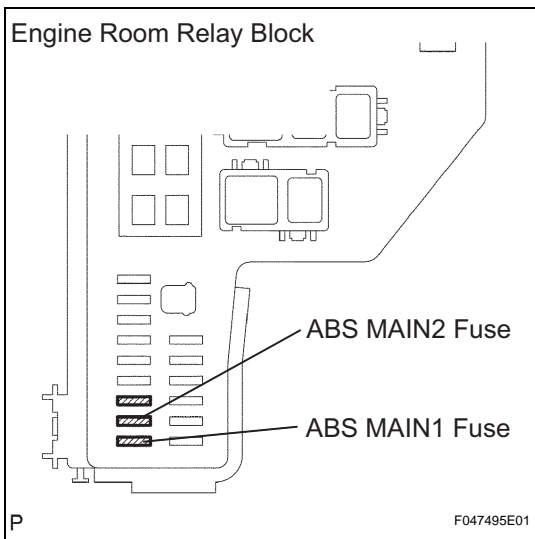

- (a) Remove the ABS MAIN1 and ABS MAIN2 fuses from the engine room relay block.
 (b) Measure the resistance of the fuses.

Standard resistance:

Below 1 Ω

NG → **CHECK FOR SHORT IN ALL HARNESS AND CONNECTOR CONNECTED TO FUSE AND REPLACE FUSE**

OK

4 INSPECT ABS MAIN RELAY (Marking: ABS NO. 1, ABS NO. 2)

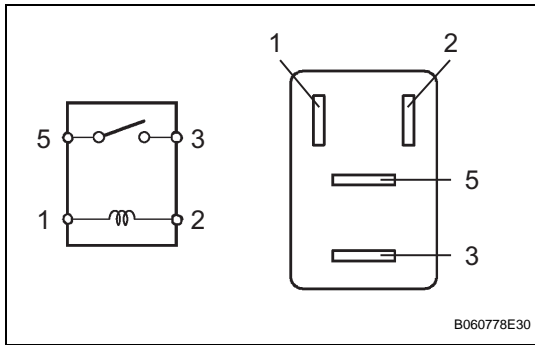

- (a) Remove the ABS NO. 1 and ABS NO. 2 relays from the engine room relay block.
 - (b) Measure the resistance of the relays.
- Standard resistance**

Tester Connection	Specified Condition
3 - 5	10 kΩ or higher
3 - 5	Below 1 Ω (when battery voltage is applied to terminals 1 and 2)

NG → **REPLACE RELAY**

OK

5 CHECK SKID CONTROL ECU (+BI1, +BI2 VOLTAGE)

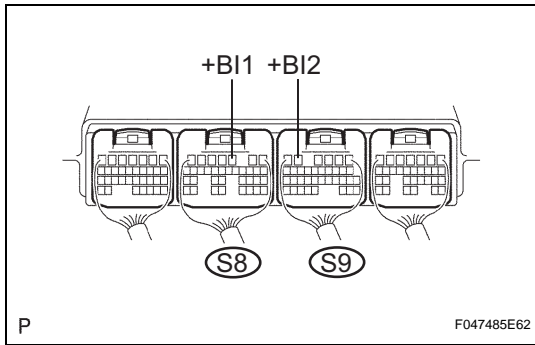

- (a) Measure the voltage of the connectors.
- HINT:**
Measure the voltage from behind the connector with the connector connected to the skid control ECU.
- Standard voltage**

Tester Connection	Specified Condition
S8-3 (+BI1) - Body ground	10 to 14 V
S9-5 (+BI2) - Body ground	10 to 14 V

NG → **REPAIR OR REPLACE HARNESS AND CONNECTOR**

OK

6 CHECK SKID CONTROL ECU (+BO1, +BO2, R1+, R2+ VOLTAGE)

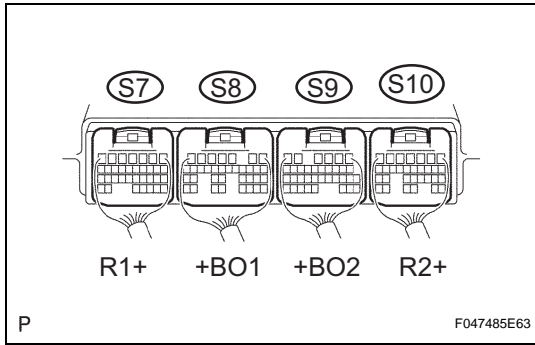

- (a) Measure the voltage of the connectors.
- HINT:**
Measure the voltage from behind the connector with the connector connected to the skid control ECU.
- Standard voltage**

Tester Connection	Specified Condition
S7-2 (R1+) - Body ground	10 to 14 V
S8-5 (+BO1) - Body ground	10 to 14 V
S9-4 (+BO2) - Body ground	10 to 14 V
S10-17 (R2+) - Body ground	10 to 14 V

NG → **REPAIR OR REPLACE HARNESS AND CONNECTOR**

OK

7 CHECK SKID CONTROL ECU (BS1, BS2 VOLTAGE)

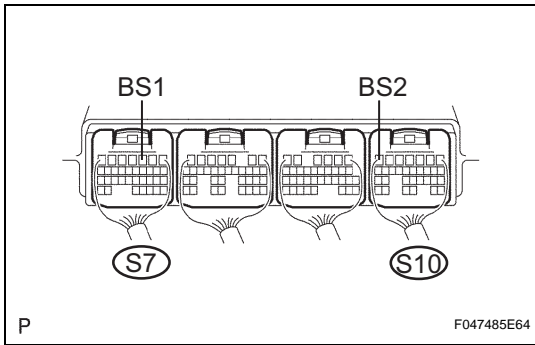

(a) Measure the voltage of the connectors.

HINT:

Measure the voltage from behind the connector with the connector connected to the skid control ECU.

Standard voltage

Tester Connection	Specified Condition
S7-3 (BS1) - Body ground	10 to 14 V
S10-7 (BS2) - Body ground	10 to 14 V

NG

REPAIR OR REPLACE HARNESS AND CONNECTOR

OK

REPLACE SKID CONTROL ECU

DTC	C1315/31	SMC1 Changeover Solenoid Malfunction
DTC	C1316/32	SMC2 Changeover Solenoid Malfunction
DTC	C1352/21	Front Increasing Pressure Solenoid RH Malfunction
DTC	C1353/23	Front Increasing Pressure Solenoid LH Malfunction
DTC	C1354/25	Rear Increasing Pressure Solenoid RH Malfunction
DTC	C1355/27	Rear Increasing Pressure Solenoid LH Malfunction
DTC	C1356/22	Front Decreasing Pressure Solenoid RH Malfunction
DTC	C1357/24	Front Decreasing Pressure Solenoid LH Malfunction
DTC	C1358/26	Rear Decreasing Pressure Solenoid RH Malfunction
DTC	C1359/28	Rear Decreasing Pressure Solenoid LH Malfunction

DESCRIPTION

Each solenoid adjusts pressure which affects each wheel cylinder according to signals from the skid control ECU and controls the vehicle.

The master cut solenoid (SMC 1/2) is closed and blocks the master cylinder pressure from the ECB control pressure when the system is normal. The master cut solenoid is open and sends the master cylinder fluid pressure to the non-assisted brake wheel cylinders during the fail-safe due to system malfunction.

DTC No.	INF Code	DTC Detection Condition	Trouble Area
C1315/31	61	When either condition below is met: <ul style="list-style-type: none"> • SMC1 drive circuit is malfunctioning for 0.05 sec. or more. • Short to +B. 	<ul style="list-style-type: none"> • Brake actuator assembly (SMC1) • Skid control ECU • Harness and connector
C1315/31	62	Open circuit in SMC1 continues for 0.05 sec. or more when SMC1 is off	<ul style="list-style-type: none"> • Brake actuator assembly (SMC1) • Skid control ECU • Harness and connector

DTC No.	INF Code	DTC Detection Condition	Trouble Area
C1315/31	63	Open circuit in SMC1 continues for 0.05 sec. or more when SMC1 is off.	<ul style="list-style-type: none"> • Brake actuator assembly (SMC1) • Skid control ECU • Harness and connector
C1315/31	64	Over current in SMC1 continues for 0.05 sec. or more.	<ul style="list-style-type: none"> • Brake actuator assembly (SMC1) • Skid control ECU • Harness and connector
C1316/32	66	When either condition below is met: <ul style="list-style-type: none"> • SMC1 driver circuit is malfunctioning for 0.05 sec. or more. • Short to +B 	<ul style="list-style-type: none"> • Brake actuator assembly (SMC2) • Skid control ECU • Harness and connector
C1316/32	67	Open circuit in SMC2 continues for 0.05 sec. or more when SMC2 is off.	<ul style="list-style-type: none"> • Brake actuator assembly (SMC2) • Skid control ECU • Harness and connector
C1316/32	68	Open circuit in SMC2 continues for 0.05 sec. or more.	<ul style="list-style-type: none"> • Brake actuator assembly (SMC2) • Skid control ECU • Harness and connector
C1316/32	69	Over current in SMC2 continues for 0.05 sec. or more.	<ul style="list-style-type: none"> • Brake actuator assembly (SMC2) • Skid control ECU • Harness and connector
C1352/21	11	Open circuit in SLAFR continues for 0.05 sec. or more when SLAFR is off.	<ul style="list-style-type: none"> • Brake actuator assembly • Skid control ECU • Harness and connector
C1352/21	12	Open circuit in SLAFR continues for 0.05 sec. or more when SLAFR is on.	<ul style="list-style-type: none"> • Brake actuator assembly • Skid control ECU • Harness and connector
C1352/21	13	Short to +B or voltage leak in SLAFR continues for 0.05 sec. or more.	<ul style="list-style-type: none"> • Brake actuator assembly • Skid control ECU • Harness and connector
C1352/21	14	Over current in SLAFR continues for 0.05 sec. or more.	<ul style="list-style-type: none"> • Brake actuator assembly • Skid control ECU • Harness and connector
C1353/23	21	Open circuit in SLAFL continues for 0.05 sec. or more when SLAFL is off.	<ul style="list-style-type: none"> • Brake actuator assembly • Skid control ECU • Harness and connector
C1353/23	22	Open circuit in SLAFL continues for 0.05 sec. or more when SLAFL is on.	<ul style="list-style-type: none"> • Brake actuator assembly • Skid control ECU • Harness and connector
C1353/23	23	Short to +B or voltage leak in SLAFL continues for 0.05 sec. or more.	<ul style="list-style-type: none"> • Brake actuator assembly • Skid control ECU • Harness and connector
C1353/23	24	Over current in SLAFL continues for 0.05 sec. or more.	<ul style="list-style-type: none"> • Brake actuator assembly • Skid control ECU • Harness and connector
C1354/25	31	Open circuit in SLARR continues for 0.05 sec. or more when SLARR is off.	<ul style="list-style-type: none"> • Brake actuator assembly • Skid control ECU • Harness and connector
C1354/25	32	Open circuit in SLARR continues for 0.05 sec. or more when SLARR is on.	<ul style="list-style-type: none"> • Brake actuator assembly • Skid control ECU • Harness and connector
C1354/25	33	Short to +B or voltage leak in SLARR continues for 0.05 sec. or more.	<ul style="list-style-type: none"> • Brake actuator assembly • Skid control ECU • Harness and connector
C1354/25	34	Over current in SLARR continues for 0.05 sec. or more.	<ul style="list-style-type: none"> • Brake actuator assembly • Skid control ECU • Harness and connector

DTC No.	INF Code	DTC Detection Condition	Trouble Area
C1355/27	41	Open circuit in SLARL continues for 0.05 sec. or more when SLARL is off.	<ul style="list-style-type: none"> • Brake actuator assembly • Skid control ECU • Harness and connector
C1355/27	42	Open circuit in SLARL continues for 0.05 sec. or more when SLARL is on.	<ul style="list-style-type: none"> • Brake actuator assembly • Skid control ECU • Harness and connector
C1355/27	43	Short to +B or voltage leak in SLARL continues for 0.05 sec. or more.	<ul style="list-style-type: none"> • Brake actuator assembly • Skid control ECU • Harness and connector
C1355/27	44	Over current in SLARL continues for 0.05 sec. or more.	<ul style="list-style-type: none"> • Brake actuator assembly • Skid control ECU • Harness and connector
C1356/22	16	Open circuit in SLRFR continues for 0.05 sec. or more when SLRFR is off.	<ul style="list-style-type: none"> • Brake actuator assembly • Skid control ECU • Harness and connector
C1356/22	17	Open circuit in SLRFR continues for 0.05 sec. or more when SKRFR is on.	<ul style="list-style-type: none"> • Brake actuator assembly • Skid control ECU • Harness and connector
C1356/22	18	Short to +B or voltage leak in SLRFR continues for 0.05 sec. or more.	<ul style="list-style-type: none"> • Brake actuator assembly • Skid control ECU • Harness and connector
C1356/22	19	Over current in SLRFR continues for 0.05 sec. or more.	<ul style="list-style-type: none"> • Brake actuator assembly • Skid control ECU • Harness and connector
C1357/24	26	Open circuit in SLRFL continues or 0.05 sec. or more when SLRFL is off.	<ul style="list-style-type: none"> • Brake actuator assembly • Skid control ECU • Harness and connector
C1357/24	27	Open circuit in SLRFL continues for 0.05 sec. or more when SLRFL is on.	<ul style="list-style-type: none"> • Brake actuator assembly • Skid control ECU • Harness and connector
C1357/24	28	Short to +B or voltage leak in SLRFL continues for 0.05 sec. or more.	<ul style="list-style-type: none"> • Brake actuator assembly • Skid control ECU • Harness and connector
C1357/24	29	Over current in SLRFL continues for 0.05 sec. or more.	<ul style="list-style-type: none"> • Brake actuator assembly • Skid control ECU • Harness and connector
C1358/26	36	Open circuit in SLRRR continues for 0.05 sec. or more when SLRRR is off.	<ul style="list-style-type: none"> • Brake actuator assembly • Skid control ECU • Harness and connector
C1358/26	37	Open circuit in SLRRR continues for 0.05 sec. or more when SLRRR is on.	<ul style="list-style-type: none"> • Brake actuator assembly • Skid control ECU • Harness and connector
C1358/26	38	Short to +B or voltage leak in SLRRR continues for 0.05 sec. or more.	<ul style="list-style-type: none"> • Brake actuator assembly • Skid control ECU • Harness and connector
C1358/26	39	Over current in SLRRR continues for 0.05 sec. or more.	<ul style="list-style-type: none"> • Brake actuator assembly • Skid control ECU • Harness and connector
C1359/28	46	Open circuit in SLRRL continues for 0.05 sec. or more when SLRRL is off.	<ul style="list-style-type: none"> • Brake actuator assembly • Skid control ECU • Harness and connector
C1359/28	47	Open circuit in SLRRL continues for 0.05 sec. or more when SLRRL is on.	<ul style="list-style-type: none"> • Brake actuator assembly • Skid control ECU • Harness and connector
C1359/28	48	Short to +B or voltage leak in SLRRL continues for 0.05 sec. or more.	<ul style="list-style-type: none"> • Brake actuator assembly • Skid control ECU • Harness and connector
C1359/28	49	Over current in SLRRL continues for 0.05 sec. or more.	<ul style="list-style-type: none"> • Brake actuator assembly • Skid control ECU • Harness and connector

WIRING DIAGRAM

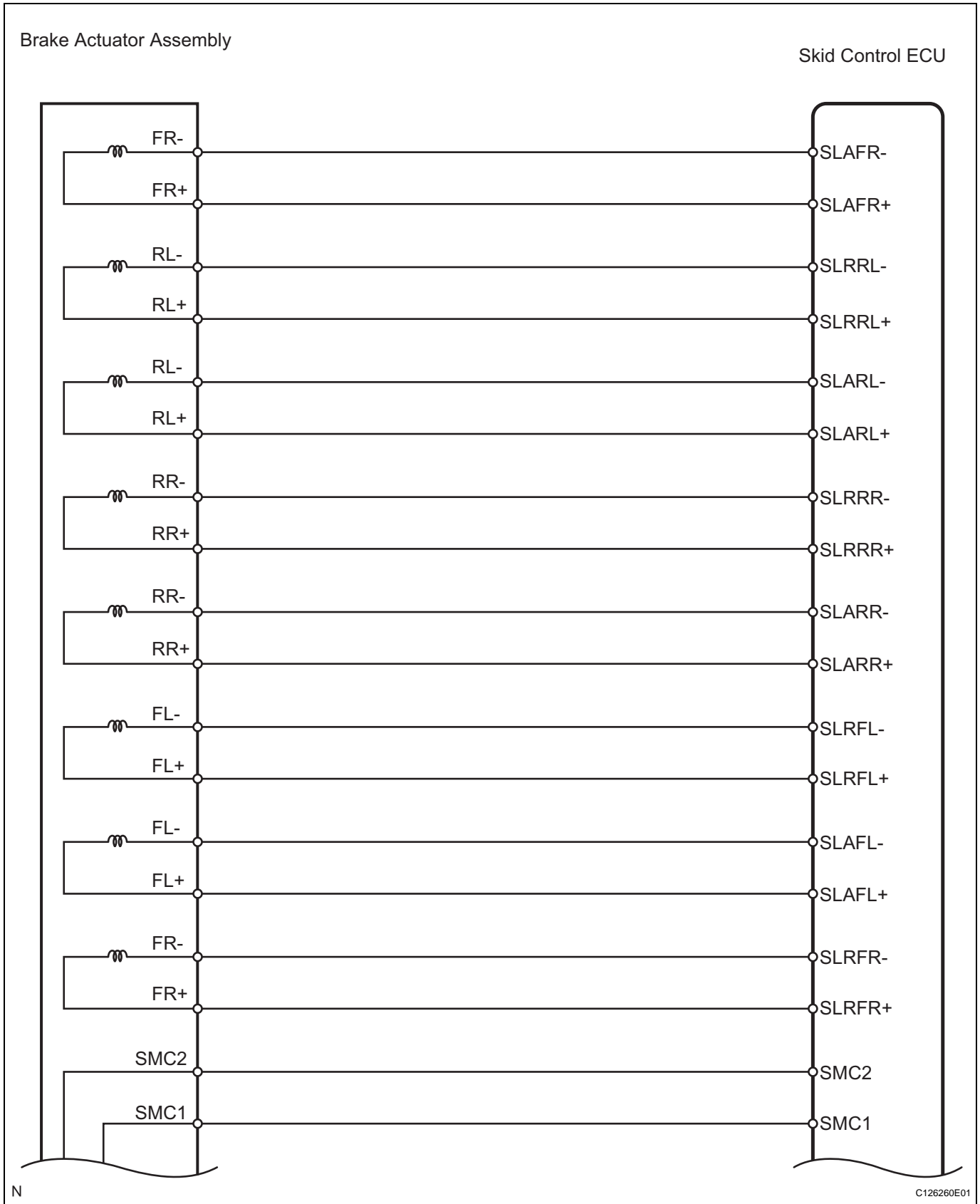

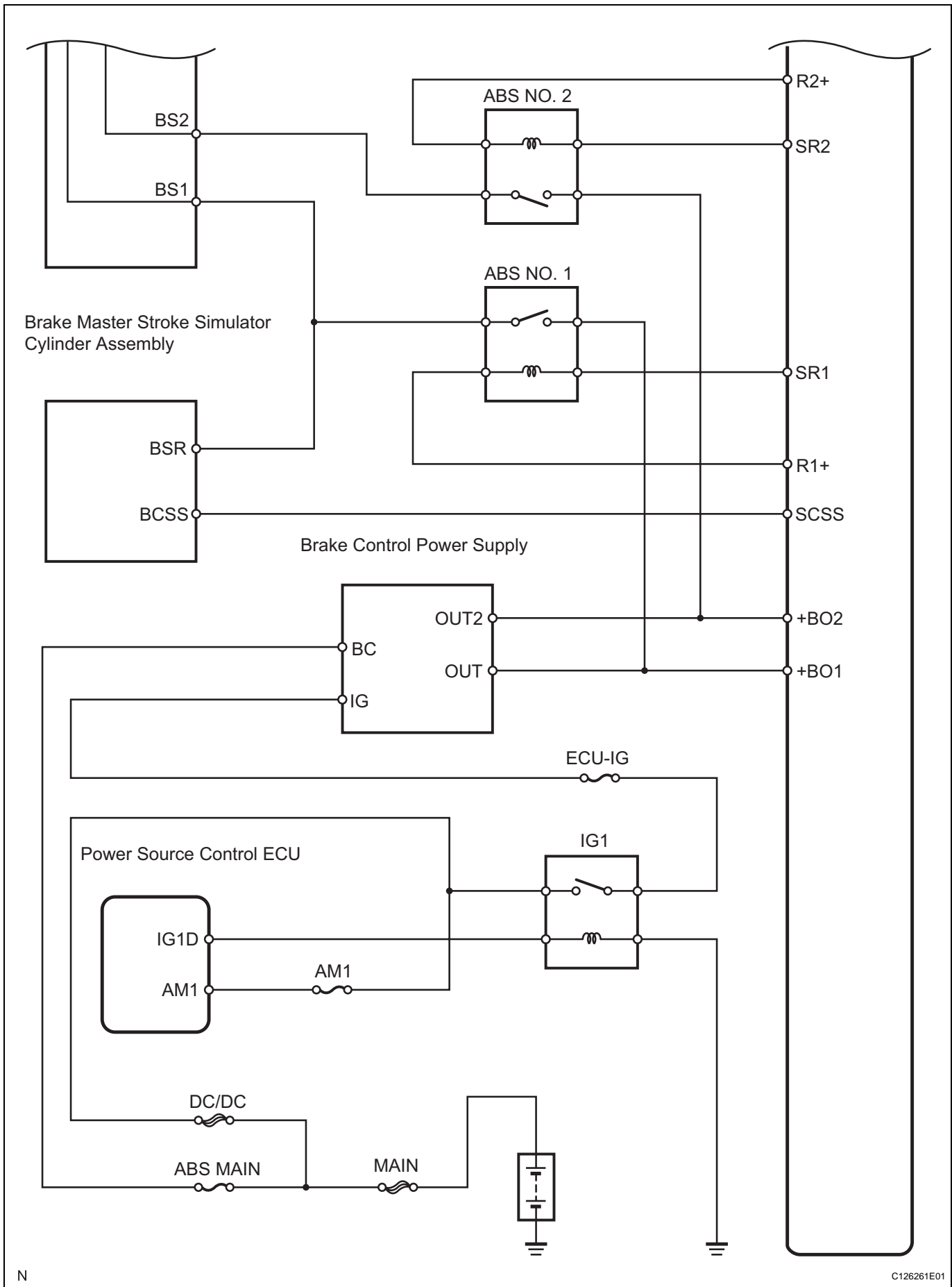

BC

INSPECTION PROCEDURE

NOTICE:

When replacing the skid control ECU, perform initialization of linear solenoid valve and calibration (see page BC-19).

1 INSPECT BRAKE ACTUATOR ASSEMBLY

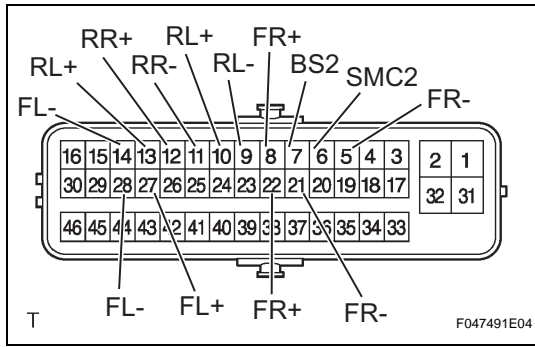

- (a) Disconnect the brake actuator connector.
 - (b) Measure the resistance of the actuator.
- HINT:
Check the brake actuator when it is cooled down.

Standard resistance

Tester Connection	Specified Condition
20 (SMC1) - 7 (BS2)	14.6 to 24.6 Ω
6 (SMC2) - 19 (BS1)	14.6 to 24.6 Ω
8 (FR+) - 5 (FR-)	3.5 to 4.3 Ω
22 (FR+) - 21 (FR-)	3.5 to 4.3 Ω
13 (FL+) - 14 (FL-)	3.5 to 4.3 Ω
27 (FL+) - 28 (FL-)	3.5 to 4.3 Ω
12 (RR+) - 11 (RR-)	3.5 to 4.3 Ω
10 (RL+) - 9 (RL-)	3.5 to 4.3 Ω

NG → REPLACE BRAKE ACTUATOR ASSEMBLY

OK

2 CHECK SKID CONTROL ECU (VALVE VOLTAGE)

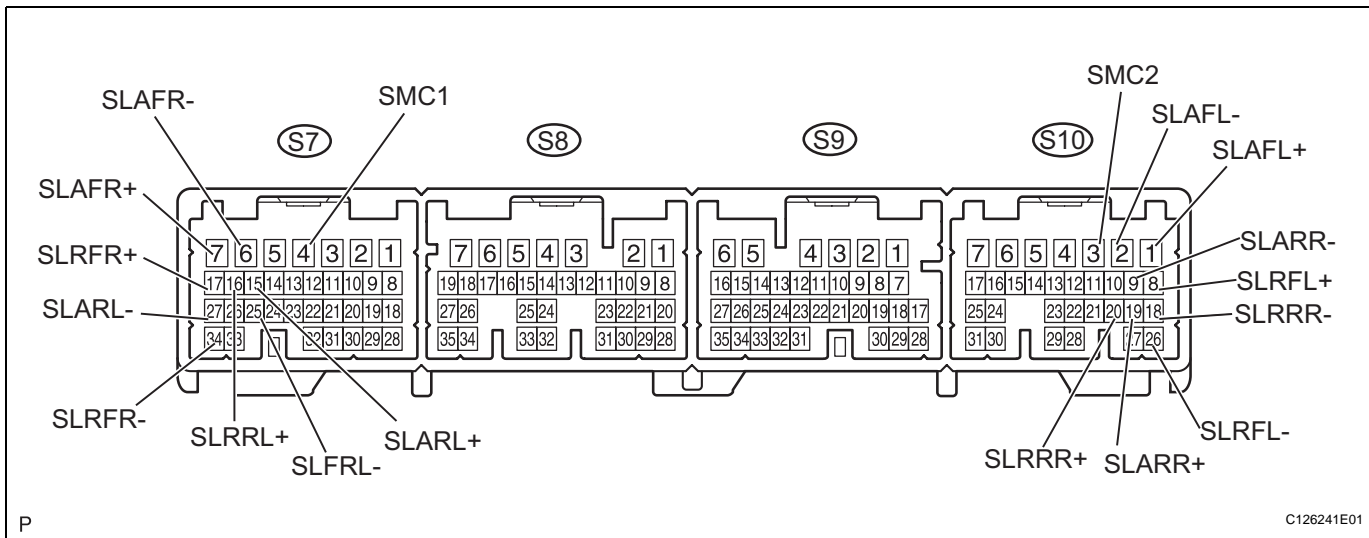

- (a) Measure the voltage of the ECU connector.
- Standard voltage**

Tester Connection	Condition	Specified Condition
S7-4 (SMC1) - Body ground	Power switch ON (READY) Brake pedal released	Below 10 to 14 V

Tester Connection	Condition	Specified Condition
S10-3 (SMC2) - Body ground	Power switch ON (READY) Brake pedal released	Below 10 to 14 V
S7-7 (SLAFR+) - Body ground	Power switch ON (READY) Brake pedal released	Pulse generation*
S7-6 (SLAFR-) - Body ground	Power switch ON (READY) Brake pedal released	Pulse generation*
S10-1 (SLAFL+) - Body ground	Power switch ON (READY) Brake pedal released	Pulse generation*
S10-2 (SLAFL-) - Body ground	Power switch ON (READY) Brake pedal released	Pulse generation*
S10-19 (SLARR+) - Body ground	Power switch ON (READY) Brake pedal released	Pulse generation*
S10-9 (SLARR-) - Body ground	Power switch ON (READY) Brake pedal released	Pulse generation*
S7-15 (SLARL+) - Body ground	Power switch ON (READY) Brake pedal released	Pulse generation*
S7-27 (SLARL-) - Body ground	Power switch ON (READY) Brake pedal released	Pulse generation*
S7-17 (SLRFR+) - Body ground	Power switch ON (READY) Brake pedal released	Below 1.5 V
S10-8 (SLRFL+) - Body ground	Power switch ON (READY) Brake pedal released	Below 1.5 V
S10-20 (SLRRR+) - Body ground	Power switch ON (READY) Brake pedal released	Below 1.5 V
S7-16 (SLRRL+) - Body ground	Power switch ON (READY) Brake pedal released	Below 1.5 V
S7-34 (SLRFR-) - Body ground	Power switch ON (READY)	Below 1.5 V
S10-26 (SLRFL-) - Body ground	Power switch ON (READY) Brake pedal released	Below 1.5 V
S10-18 (SLRRR-) - Body ground	Power switch ON (READY) Brake pedal released	Below 1.5 V
S7-26 (SLRRL-) - Body ground	Power switch ON (READY) Brake pedal released	Below 1.5 V

HINT:

*: Refer to waveform 5 of "TERMINALS OF ECU" (see page [BC-29](#)).

NG

REPAIR OR REPLACE HARNESS AND CONNECTOR

OK

REPLACE SKID CONTROL ECU

DTC**C1319/35****SCSS Changeover Solenoid Malfunction****DESCRIPTION**

The stroke simulator solenoid (SCSS) generates pedal reactive effort during ECB control. If one of the 4 wheels loses brake booster function, the stroke simulator operation is prohibited.

DTC No.	INF Code	DTC Detection Condition	Trouble Area
C1319/35	71	When either condition below is met: <ul style="list-style-type: none"> • SCSS drive circuit is malfunctioning for 0.05 sec. or more. • Short to +B in SCSS 	<ul style="list-style-type: none"> • Stroke simulator • Skid control ECU • Harness and connector
C1319/35	72	Current leaks for 0.05 sec. or more when SCSS is off.	<ul style="list-style-type: none"> • Stroke simulator • Skid control ECU • Harness and connector
C1319/35	73	Open circuit in SCSS continues for 0.05 sec. or more.	<ul style="list-style-type: none"> • Stroke simulator • Skid control ECU • Harness and connector
C1319/35	74	Over current in SCSS continues for 0.05 sec. or more.	<ul style="list-style-type: none"> • Stroke simulator • Skid control ECU • Harness and connector

WIRING DIAGRAM

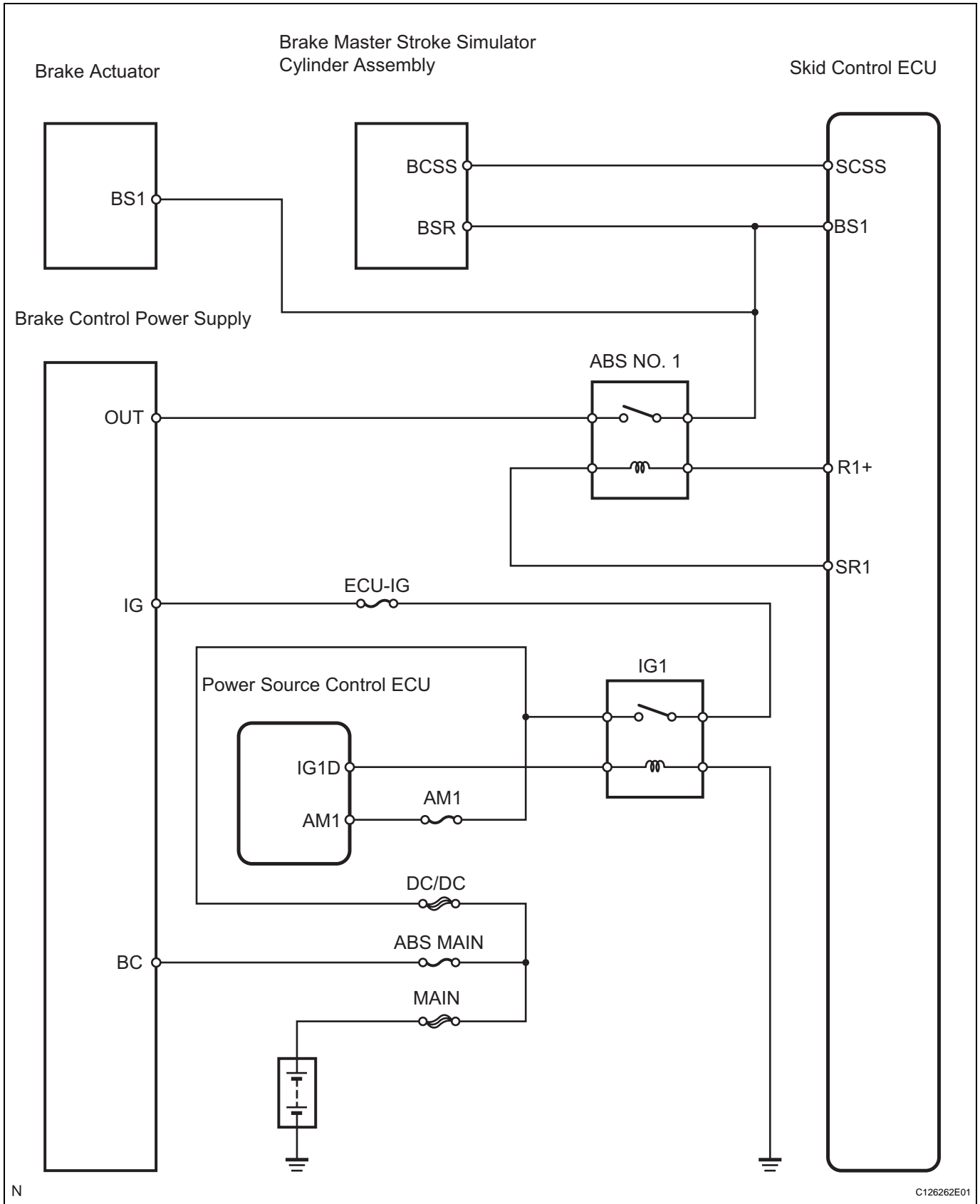

N

C126262E01

BC

INSPECTION PROCEDURE

NOTICE:

When replacing the skid control ECU, perform initialization of linear solenoid valve and calibration (see page BC-19).

1 INSPECT BRAKE MASTER STROKE SIMULATOR CYLINDER ASSEMBLY

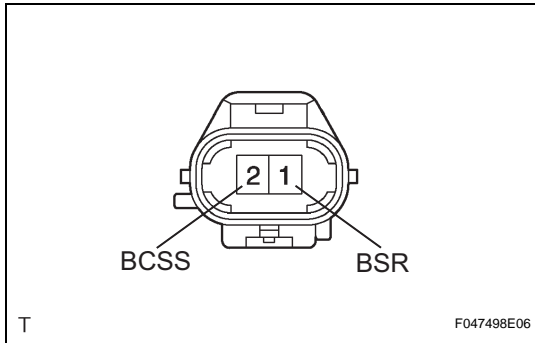

- (a) Disconnect brake master stroke simulator cylinder connector.
 - (b) Measure the resistance of the cylinder.
- Standard resistance**

Tester Connection	Specified Condition
1 (BSR) - 2 (BCSS)	22.3 to 38 Ω

NG → **REPLACE BRAKE MASTER STROKE SIMULATOR CYLINDER ASSEMBLY**

OK

2 CHECK BRAKE MASTER STROKE SIMULATOR CYLINDER ASSEMBLY (BSR VOLTAGE)

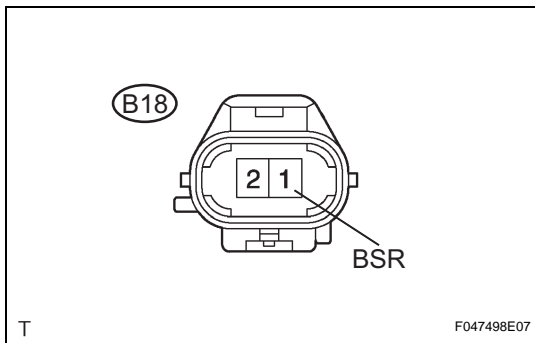

- (a) Connect the brake master stroke simulator cylinder connector.
 - (b) Measure the voltage of the connector.
- HINT:**
Measure the voltage from the behind the connector with the connector connected.
- Standard voltage**

Tester Connection	Condition	Specified Condition
B17-1 (BSR) - Body ground	Power switch ON (READY)	10 to 14 V

NG → **REPAIR OR REPLACE HARNESS AND CONNECTOR**

OK

3 CHECK SKID CONTROL ECU (SCSS VOLTAGE)

BC

- (a) Select the ACTIVE TEST mode on the intelligent tester.

Skid control ECU

Item	Test Details	Diagnostic Note
SCC PATTERN	Stroke simulator cut valve pattern activation ON / OFF	Operation of solenoid (clicking sound) can be heard

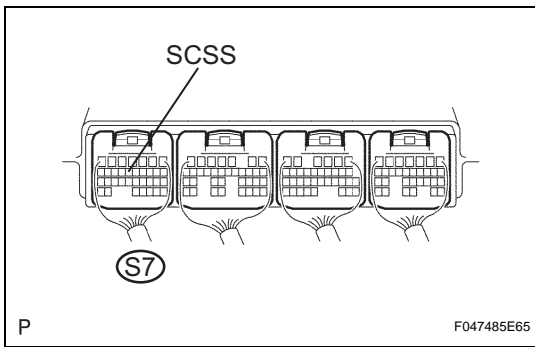

(b) Use the ACTIVE TEST commands shown below to turn the stroke simulator cylinder ON or OFF, and measure the voltage of the SCSS terminal.

Standard voltage

Tester Connection	Condition	Specified Condition
S7-13 (SCSS) - Body ground	Brake master stroke simulator cylinder ON	Below 1.5 V
S7-13 (SCSS) - Body ground	Brake master stroke simulator cylinder OFF	10 to 14 V

NG → **REPAIR OR REPLACE HARNESS AND CONNECTOR**

OK

REPLACE SKID CONTROL ECU

DTC	C1341/62	Front Hydraulic System RH Malfunction
DTC	C1342/63	Front Hydraulic System LH Malfunction
DTC	C1343/64	Rear Hydraulic System RH Malfunction
DTC	C1344/65	Rear Hydraulic System LH Malfunction

DESCRIPTION

The skid control ECU controls braking force according to the hybrid system regenerative braking force and inputs the fluid pressure necessary for operating each wheel cylinder according to the wheel cylinder pressure sensor.

DTCs may be stored if brake fluid leaks, wheel cylinder vibrates due to uneven wear of the brake disc rotor, or foreign matter enters the solenoid valve.

DTCs may be stored if the line pressure drops during air bleeding.

DTC No.	INF Code	DTC Detection Condition	Trouble Area
C1341/62	551	Hydraulic pressure control on FR wheel has deteriorated.	<ul style="list-style-type: none"> Fluid leakage Brake actuator assembly
C1341/62	552	Hydraulic pressure control on FR wheel has deteriorated.	<ul style="list-style-type: none"> Fluid leakage Brake actuator assembly
C1341/62	553	There is a malfunction, such as leakage in the pressure increase control valve of FR wheel.	<ul style="list-style-type: none"> Fluid leakage Brake actuator assembly Disc rotor
C1341/62	554	There is a malfunction, such as leakage in the pressure decrease control valve of FR wheel.	<ul style="list-style-type: none"> Fluid leakage Brake actuator assembly Disc rotor
C1341/62	555	There is a malfunction, such as leakage in the pressure decrease control valve of FR wheel.	<ul style="list-style-type: none"> Fluid leakage Brake actuator assembly Disc rotor
C1342/63	561	Hydraulic pressure control on FL wheel has deteriorated.	<ul style="list-style-type: none"> Fluid leakage Brake actuator
C1342/63	562	Hydraulic pressure control on FL wheel has deteriorated.	<ul style="list-style-type: none"> Fluid leakage Brake actuator
C1342/63	563	There is a malfunction, such as leakage in pressure increase control valve of FL wheel.	<ul style="list-style-type: none"> Fluid leakage Brake actuator assembly Disc rotor
C1342/63	564	There is a malfunction, such as leakage in pressure decrease control valve of FL wheel.	<ul style="list-style-type: none"> Fluid leakage Brake actuator assembly Disc rotor
C1342/63	565	There is a malfunction, such as leakage in pressure decrease control valve of FL wheel.	<ul style="list-style-type: none"> Fluid leakage Brake actuator assembly Disc rotor
C1343/64	571	Hydraulic pressure control on RR wheel has deteriorated.	<ul style="list-style-type: none"> Fluid leakage Brake actuator
C1343/64	572	Hydraulic pressure control on RR wheel has deteriorated.	<ul style="list-style-type: none"> Fluid leakage Brake actuator
C1343/64	573	There is a malfunction, such as leakage in pressure increase control valve of RR wheel.	<ul style="list-style-type: none"> Fluid leakage Brake actuator assembly Disc rotor
C1343/64	574	There is a malfunction, such as leakage in pressure decrease control valve of RR wheel.	<ul style="list-style-type: none"> Fluid leakage Brake actuator assembly Disc rotor
C1343/64	575	There is a malfunction, such as leakage in pressure decrease control valve of RR wheel.	<ul style="list-style-type: none"> Fluid leakage Brake actuator assembly Disc rotor

DTC No.	INF Code	DTC Detection Condition	Trouble Area
C1344/65	581	Hydraulic pressure control on RL wheel has deteriorated.	<ul style="list-style-type: none">• Fluid leakage• Brake actuator
C1344/65	582	Hydraulic pressure control on RL wheel has deteriorated.	<ul style="list-style-type: none">• Fluid leakage• Brake actuator
C1344/65	583	There is a malfunction, such as leakage in pressure increase control valve of RR wheel.	<ul style="list-style-type: none">• Fluid leakage• Brake actuator assembly• Disc rotor
C1344/65	584	There is a malfunction, such as leakage in pressure decrease control valve of RR wheel.	<ul style="list-style-type: none">• Fluid leakage• Brake actuator assembly• Disc rotor
C1344/65	585	There is a malfunction, such as leakage in pressure decrease control valve of RL wheel.	<ul style="list-style-type: none">• Fluid leakage• Brake actuator assembly• Disc rotor

WIRING DIAGRAM

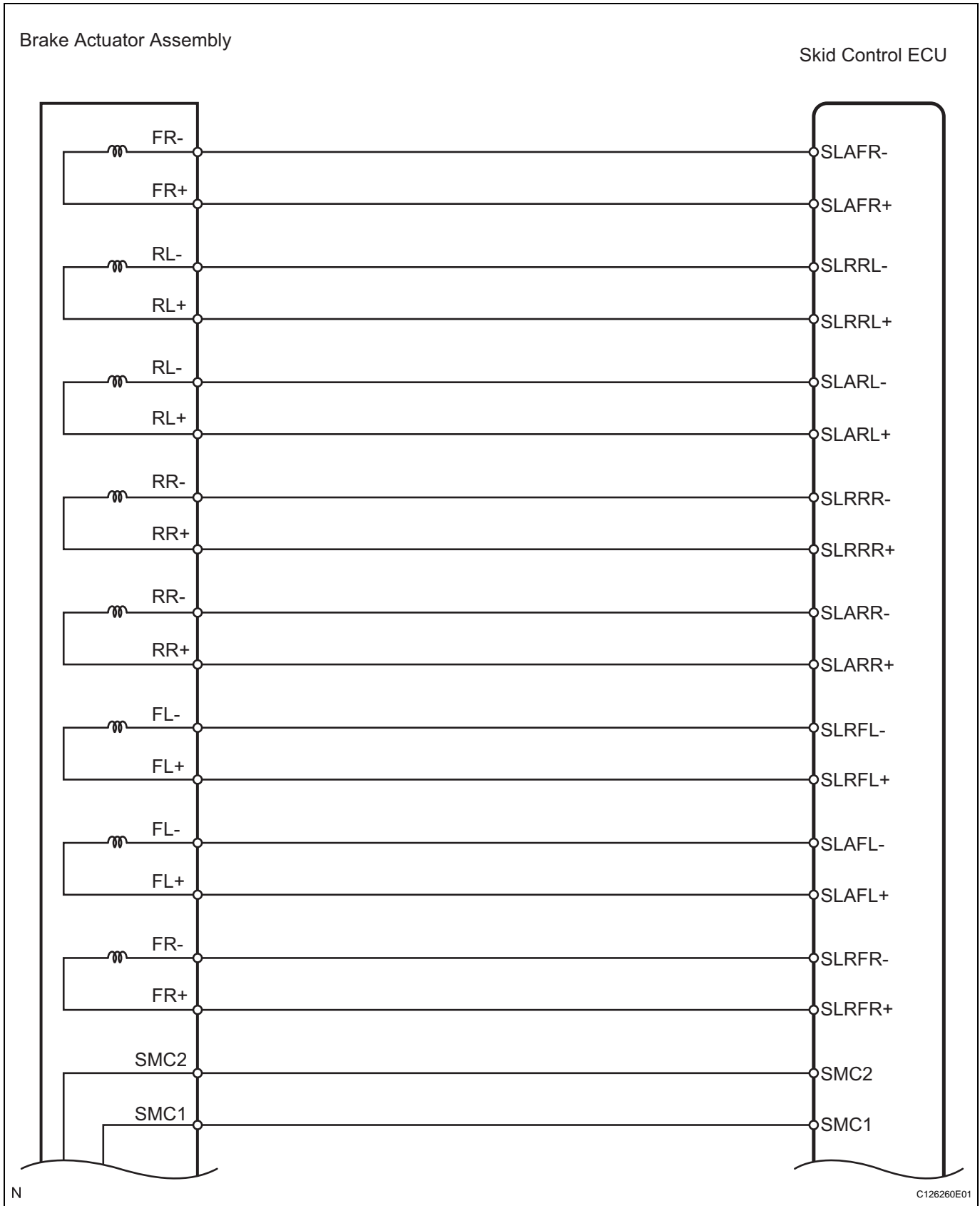

BC

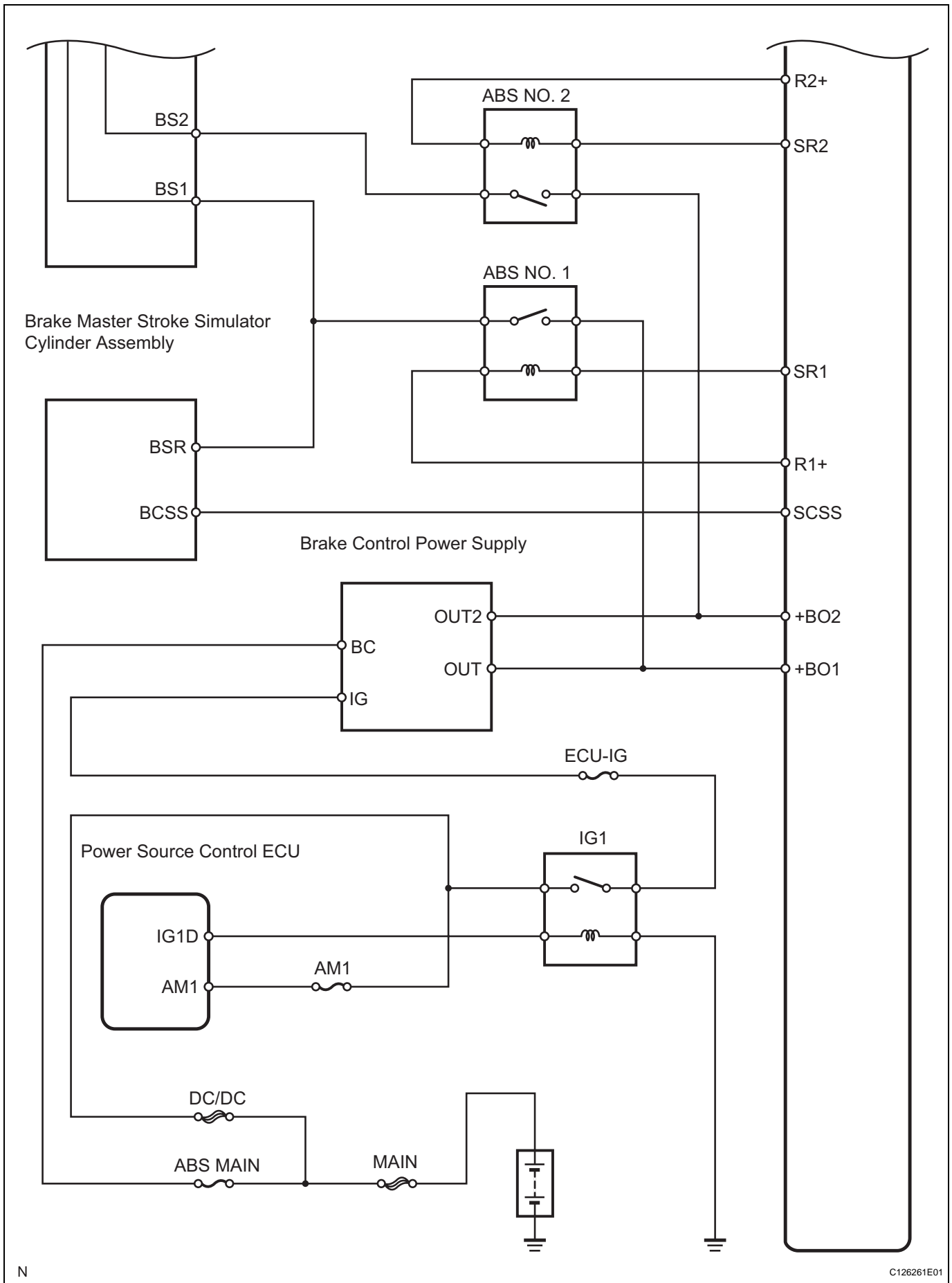

BC

INSPECTION PROCEDURE

NOTICE:

When replacing the skid control ECU, perform initialization of linear solenoid valve and calibration (see page [BC-19](#)).

HINT:

When C1364/61 is output together with C1341/62, C1342/63, C1343/64 and C1344/65, inspect and repair the trouble areas indicated by C1364/61 first.

1 CHECK BRAKE FLUID LEAKAGE

- (a) Check that there is no fluid leakage in the brake line between the brake actuator and the wheel cylinder which is the cause of DTCs.
- (b) Check that the brake is not dragging.

OK:

There is no fluid leakage or dragging.

NG

REPAIR OR REPLACE APPLICABLE PART

OK

2 PERFORM AIR BLEED

- (a) Bleed the air out of the front and rear systems (see page [BR-3](#)).

NEXT

3 RECONFIRM DTC

- (a) Clear the DTCs (see page [BC-38](#)).
- (b) Turn the power switch ON (READY).
- (c) Check the same DTCs are recorded (see page [BC-38](#)).

Result

Result	Proceed to
DTC is output	A
DTC is not output	B

HINT:

DTC may be stored if foreign matter or air enters the solenoid valve.

B

END

A

4 CHECK WIRE HARNESS (SKID CONTROL ECU - BRAKE ACTUATOR)

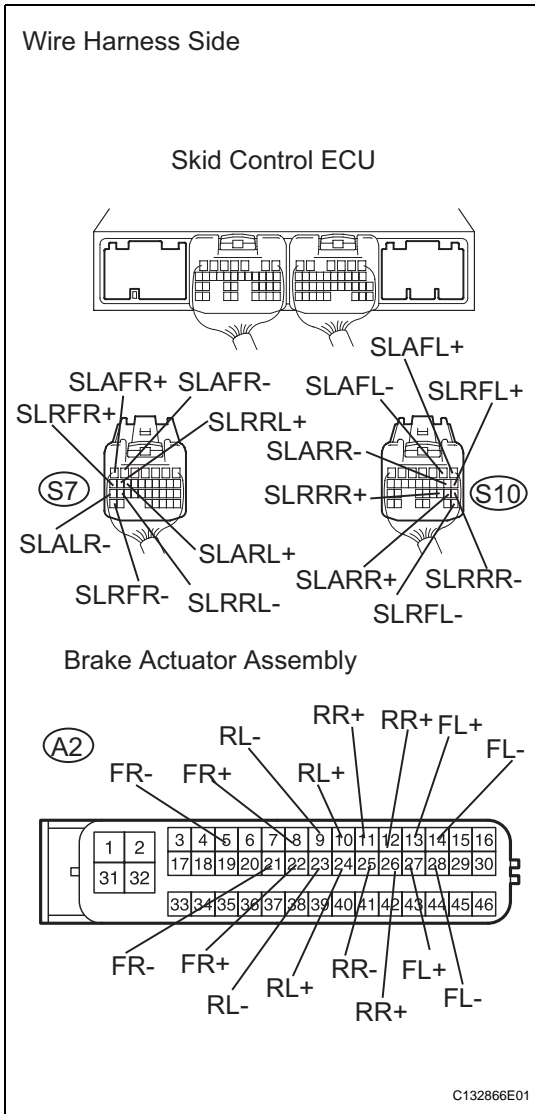

- (a) Disconnect the S7 and S10 connectors.
- (b) Disconnect the A2 actuator connector.
- (c) Measure the resistance of the wire harness side connectors.

Standard resistance

Tester Connection	Specified Condition
S7-6 (SLAFR-) - A2-5 (FR-)	Below 1 Ω
S7-7 (SLAFR+) - A2-8 (FR+)	Below 1 Ω
S7-15 (SLARL+) - A2-10 (RL+)	Below 1 Ω
S7-16 (SLRRL+) - A2-24 (RL+)	Below 1 Ω
S7-17 (SLRFR+) - A2-22 (FR+)	Below 1 Ω
S7-26 (SLRRL-) - A2-23 (RL-)	Below 1 Ω
S7-27 (SLARL-) - A2-9 (RL-)	Below 1 Ω
S7-34 (SLRFR-) - A2-21 (FR-)	Below 1 Ω
S10-1 (SLAFL+) - A2-13 (FL+)	Below 1 Ω
S10-2 (SLAFL-) - A2-14 (FL-)	Below 1 Ω
S10-8 (SLRFL+) - A2-27 (FL+)	Below 1 Ω
S10-9 (SLARR-) - A2-11 (RR-)	Below 1 Ω
S10-18 (SLRRR-) - A2-25 (RR-)	Below 1 Ω
S10-19 (SLARR+) - A2-12 (RR+)	Below 1 Ω
S10-20 (SLRRR+) - A2-26 (RR+)	Below 1 Ω
S10-26 (SLRFL-) - A2-28 (FL-)	Below 1 Ω
S7-6 (SLAFR-) - Body ground	10 kΩ or higher
S7-7 (SLAFR+) - Body ground	10 kΩ or higher
S7-15 (SLARL+) - Body ground	10 kΩ or higher
S7-16 (SLRRL+) - Body ground	10 kΩ or higher
S7-17 (SLRFR+) - Body ground	10 kΩ or higher
S7-26 (SLRRL-) - Body ground	10 kΩ or higher
S7-27 (SLARL-) - Body ground	10 kΩ or higher
S7-34 (SLRFR-) - Body ground	10 kΩ or higher
S10-1 (SLAFL+) - Body ground	10 kΩ or higher
S10-2 (SLAFL-) - Body ground	10 kΩ or higher
S10-8 (SLRFL+) - Body ground	10 kΩ or higher
S10-9 (SLARR-) - Body ground	10 kΩ or higher
S10-18 (SLRRR-) - Body ground	10 kΩ or higher
S10-19 (SLARR+) - Body ground	10 kΩ or higher
S10-20 (SLRRR+) - Body ground	10 kΩ or higher
S10-26 (SLRFL-) - Body ground	10 kΩ or higher

NG REPAIR OR REPLACE HARNESS AND CONNECTOR

OK

5 READ VALUE OF INTELLIGENT TESTER (WHEEL CYLINDER PRESSURE SENSOR)

- (a) Connect the pedal effort gauge.

- (b) Install the LSPV gauge (SST) and bleed air (see page BR-3).

SST 09709-29018

- (c) Select the DATA LIST mode on the intelligent tester.

Skid control ECU

Item	Measurement Item / Range (Display)	Normal Condition	Diagnostic Note
FR PRESS SENS	Front right pressure sensor / Min.: 0 V, Max.: 5 V	When brake pedal is released: 0.3 to 0.9 V	-
FL PRESS SENS	Front left pressure sensor / Min.: 0 V, Max.: 5 V	When brake pedal is released: 0.3 to 0.9 V	-
RR PRESS SENS	Rear right pressure sensor / Min.: 0 V, Max.: 5 V	When brake pedal is released: 0.3 to 0.9 V	-
RL PRESS SENS	Rear left pressure sensor / Min.: 0 V, Max.: 5 V	When brake pedal is released: 0.3 to 0.9 V	-

- (d) Check the output value of the wheel cylinder pressure at each fluid pressure during the ECB control.

Standard voltage

Fluid Pressure	FR PRESS SENS (DATA-LIST)	FL PRESS SENS (DATA-LIST)	RR PRESS SENS (DATA-LIST)	RL PRESS SENS (DATA-LIST)
1 MPa (10.2 kgf/cm, 145.0 psi)	0.65 to 0.75 V	0.65 to 0.75 V	0.65 to 0.75 V	0.65 to 0.75 V
3 MPa (30.6 kgf/cm, 435.2 psi)	1.05 to 1.2 V	1.05 to 1.2 V	1.05 to 1.2 V	1.05 to 1.2 V
7 MPa (71.4 kgf/cm, 1015.5 psi)	1.8 to 2.05 V	1.8 to 2.05 V	-	-
10 MPa (102.0 kgf/cm, 1450.7 psi)	2.4 to 2.7 V	2.4 to 2.7	-	-

NG

REPLACE BRAKE ACTUATOR ASSEMBLY

OK

6

CHECK BRAKE DISC

- (a) Disconnect the brake pedal stroke sensor connector.
 (b) Perform the running and braking test according to freeze frame data or customer problem analysis. Check if the brake line pressure vibration is due to uneven wear of the disc according to brake pedal vibration.

OK:

Brake pedal does not vibrate during braking.

HINT:

- The brake pedal does not kick back due to wheel cylinder piston vibration during ECB control.
- If the brake pedal stroke sensor connector is disconnected, the fail-safe function prohibits ECB control.
- The ACTIVE TEST does not prohibit ECB control when the vehicle is running, so disconnect the stroke sensor connector and perform the inspection.
- Disc wear can be checked by measuring the disc thickness.

NG

REPLACE BRAKE DISC

OK

REPLACE BRAKE ACTUATOR ASSEMBLY

DTC	C1345/66	Linear Solenoid Valve Offset Learning Undone
------------	-----------------	---

DTC	C1368/67	Linear Solenoid Valve Offset Malfunction
------------	-----------------	---

DESCRIPTION

The skid control ECU stores and corrects the difference in each individual part such as the stroke sensor, actuator solenoids, and stroke simulator solenoid. Perform "initialization of linear solenoid valve and calibration" if these parts are replaced.

The skid control ECU inputs the shift position P signal.

DTC No.	INF Code	DTC Detection Condition	Trouble Area
C1345/66	501	Value of initialization of linear solenoid valve and calibration for the FR wheel is not stored.	Initialization of linear solenoid valve and calibration undone
C1345/66	502	Value of initialization of linear solenoid valve and calibration for the FL wheel is not stored.	Initialization of linear solenoid valve and calibration undone
C1345/66	503	Value of initialization of linear solenoid valve and calibration for the RR wheel is not stored.	Initialization of linear solenoid valve and calibration undone
C1345/66	504	Value of initialization of linear solenoid valve and calibration for the RL	Initialization of linear solenoid valve and calibration undone
C1368/67	505	Wheel is not stored. Value of initialization of linear solenoid valve and calibration is not within the brake actuator's standard value.	<ul style="list-style-type: none"> Initialization of linear solenoid valve and calibration undone Skid control ECU

INSPECTION PROCEDURE

1	PERFORM INITIALIZATION OD LINEAR SOLENOID VALVE AND CALIBRATION
----------	--

- (a) Perform "initialization of linear solenoid valve and calibration" (see page [BC-19](#)).

NEXT

2	RECONFIRM DTC
----------	----------------------

- (a) Clear the DTCs (see page [BC-38](#)).
 (b) Turn the power switch ON (READY).
 (c) Check the same DTCs are recorded (see page [BC-19](#)).

Result

Result	Proceed to
DTC is not output	A
DTC is output	B

B **REPLACE BRAKE ACTUATOR ASSEMBLY**

A

END

DTC**C1365/54****Accumulator Pressure Sensor Malfunction****DESCRIPTION**

The accumulator (ACC) pressure sensor is built into the brake actuator.

The skid control ECU detects the accumulator pressure from the data sent from the accumulator pressure sensor, and then runs and stops the pump motor by operating the motor relay.

DTCs may be output if the accumulator pressure drops due to frequent braking (this is not a malfunction).

DTC No.	INF Code	DTC Detection Condition	Trouble Area
C1365/54	211	Sensor power 1 (VCM1) voltage is 4.7 V or less or 5.3 V or more for at least 0.05 sec.	<ul style="list-style-type: none"> • Brake actuator assembly (accumulator pressure sensor) • Skid control ECU
C1365/54	212	Ratio of accumulator pressure sensor output voltage (PACC) to sensor power 1 (VCM1) voltage is 5% or less or 90.5% or more for at least 0.05 sec.	<ul style="list-style-type: none"> • Brake actuator assembly (accumulator pressure sensor) • Skid control ECU
C1365/54	214	Total wheel cylinder pressure sensor exceeds 12 MPa after depressing brake pedal, but accumulator pressure sensor output voltage (PACC) changes less than 0.5 MPa for at least 0.5 sec.	<ul style="list-style-type: none"> • Brake actuator assembly (accumulator pressure sensor) • Skid control ECU
C1365/54	215	Ratio of accumulator pressure sensor output voltage (PACC) to sensor power 1 (VCM1) voltage is 90.5% or less for at least 0.1 sec. during self-diagnosis.	<ul style="list-style-type: none"> • Brake actuator assembly (accumulator pressure sensor) • Skid control ECU
C1365/54	216	Voltage difference is 0.3 V or more before and after changing the pull up resistance in sensor signal input circuit (loose contact).	<ul style="list-style-type: none"> • Brake actuator assembly (accumulator pressure sensor) • Skid control ECU

WIRING DIAGRAM

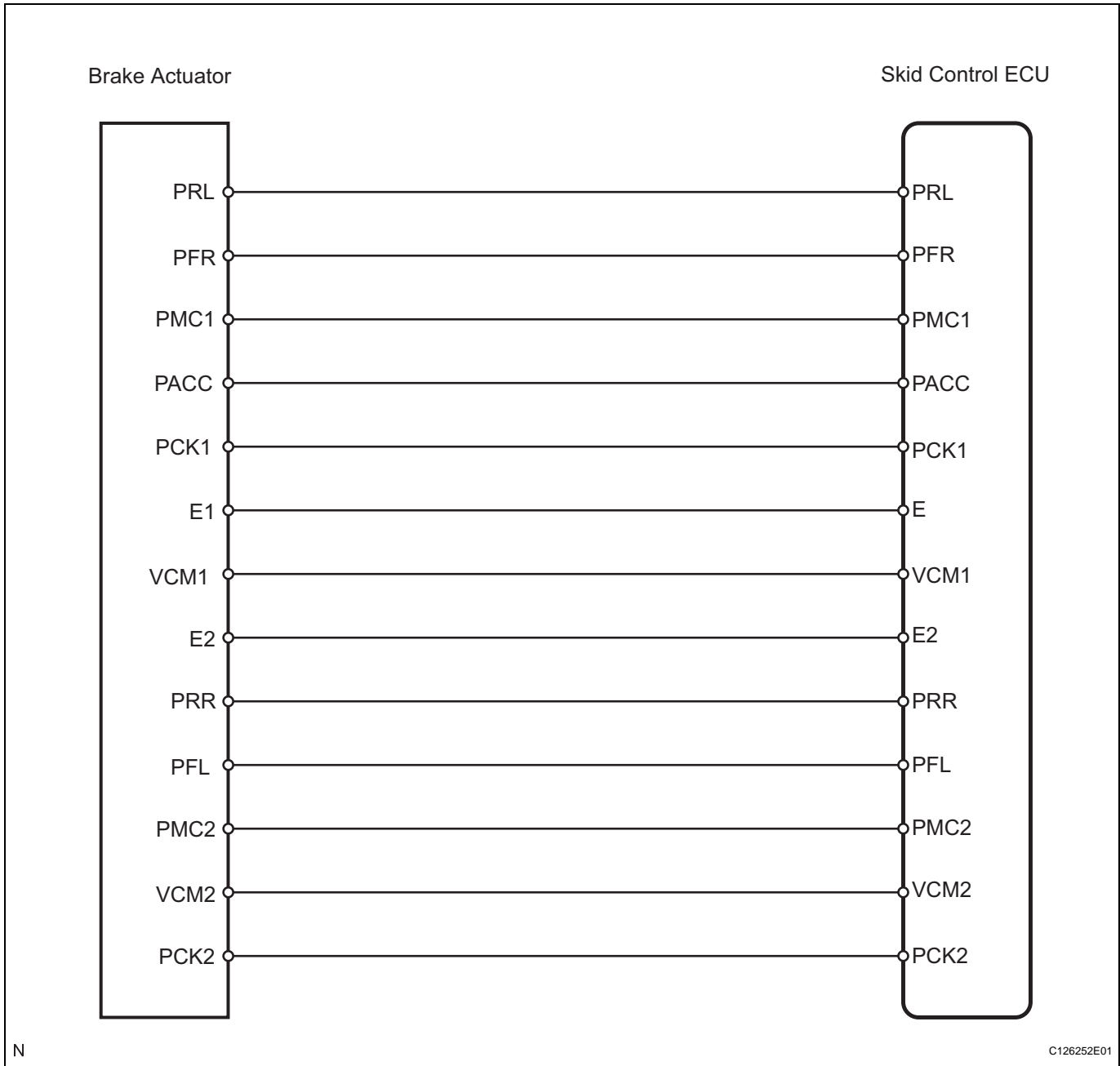

INSPECTION PROCEDURE

NOTICE:

When replacing the skid control ECU, perform initialization of linear solenoid valve and calibration (see page BC-19).



1 CHECK WIRE HARNESS (SKID CONTROL ECU - BRAKE ACTUATOR)

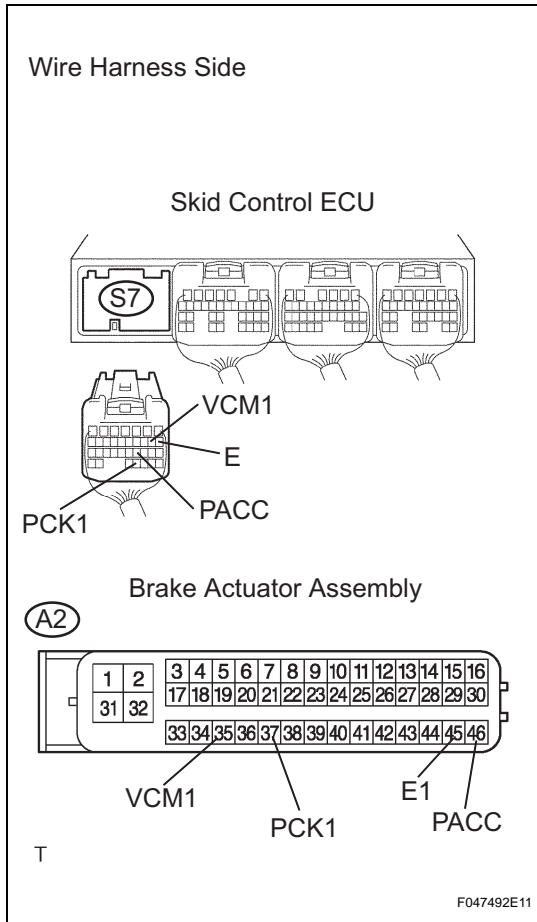

- (a) Disconnect the S7 ECU connector.
- (b) Disconnect the A2 actuator connector.
- (c) Measure the resistance of the wire harness side connectors.

Standard resistance

Tester Connection	Specified Condition
S7-8 (E) - A2-45 (E1)	Below 1 Ω
S7-9 (VCM1) - A2-35 (VCM1)	Below 1 Ω
S7-21 (PACC) - A2-46 (PACC)	Below 1 Ω
S7-31 (PCK1) - A2-37 (PCK1)	Below 1 Ω
S7-8 (E) - Body ground	10 kΩ or higher
S7-9 (VCM1) - Body ground	10 kΩ or higher
S7-21 (PACC) - Body ground	10 kΩ or higher
S7-31 (PCK1) - Body ground	10 kΩ or higher

NG REPAIR OR REPLACE HARNESS AND CONNECTOR

OK

2 CHECK SKID CONTROL ECU (VCM1 VOLTAGE)

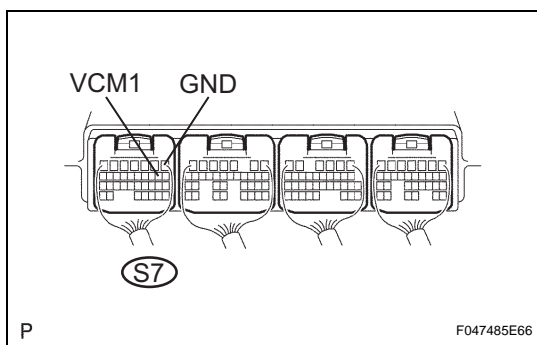

- (a) Measure the voltage of the connector.
- HINT:
Measure the voltage from behind the connector with the connector connected to the skid control ECU.

Standard voltage

Tester Connection	Condition	Specified Condition
S7-9 (VCM1) - S7-1 (GND)	Power switch ON (READY)	4.75 to 5.25 V

NG REPLACE SKID CONTROL ECU

OK

3 CHECK SKID CONTROL ECU ASSEMBLY (PACC VOLTAGE)

- (a) Check the auxiliary battery voltage.

Standard voltage:

10 to 14 V

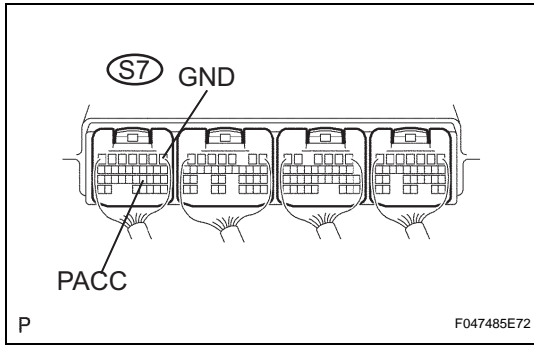

- (b) Depress the brake pedal to operate the pump motor, and then check that the pump motor stops.
- (c) Measure the voltage of the connector.
Standard voltage

Tester Connection	Specified Condition
S7-21 (PACC) - S7-1 (GND)	3.3 to 4.7 V

NOTICE:

- Do not depress the brake until after the pump motor stops and the voltage check is finished in order to keep the accumulator pressure.
- Check from behind the connector with the connector connected to the skid control ECU.
- Do not use a DATA LIST, as the sensor itself must be checked.

NG → **REPLACE BRAKE ACTUATOR ASSEMBLY**

OK

4 READ VALUE OF INTELLIGENT TESTER (ACCUMULATOR PRESSURE SENSOR)

- (a) Check the DATA LIST for proper functioning of the accumulator pressure sensor.
- (b) Depress the brake pedal 4 or 5 times to operate the pump motor, and check the output value on the intelligent tester with the motor stopped (no braking).

Skid control ECU

Item	Measurement Item / Range (Display)	Normal Condition	Diagnostic Note
ACC PRESS SENS 1	Accumulator pressure sensor 1 / Min.: 0 V, Max.: 5 V	Specified value: 3.2 to 4.0 V	-

OK:

Accumulator pressure sensor voltage does not drop.

NG → **REPLACE BRAKE ACTUATOR ASSEMBLY**

OK

REPLACE SKID CONTROL ECU

DTC**C1377/43****Capacitor Malfunction****DESCRIPTION**

The brake control power supply (capacitor) provides auxiliary power for brake control when the auxiliary battery (12 V) voltage drops.

DTC No.	INF Code	DTC Detection Condition	Trouble Area
C1377/43	101	Brake control power supply assembly is deteriorated (indicates a need to replace).	Brake control power supply
C1377/43	102	Self-discharge (current leak) is excessive (internal malfunction).	Brake control power supply
C1377/43	103	Input voltage from the auxiliary battery (12 V) to the brake control power supply is 16.4 V or more for at least 10 sec.	Brake control power supply
C1377/43	105	Circuit inside the power back up unit (charge) is malfunctioning.	Brake control power supply
C1377/43	106	Circuit inside the power back up unit (back up output circuit) is malfunctioning.	Brake control power supply
C1377/43	108	Circuit inside the power back up unit (voltage monitor circuit) is malfunctioning.	Brake control power supply
C1377/43	109	Open circuit between auxiliary battery (12 V) and brake control power supply power input (+BC terminal).	<ul style="list-style-type: none"> • Harness and connector • ABS MAIN3 fuse
C1377/43	110	When either condition below is met: <ul style="list-style-type: none"> • Open or short circuit between auxiliary battery (12 V) and brake control power supply output 1 (OUT 1). • Open or short circuit between auxiliary battery (12 V) and brake control power supply output 2 (OUT 2) 	<ul style="list-style-type: none"> • Harness and connector • ABS MAIN1 fuse • ABS MAIN2 fuse

WIRING DIAGRAM

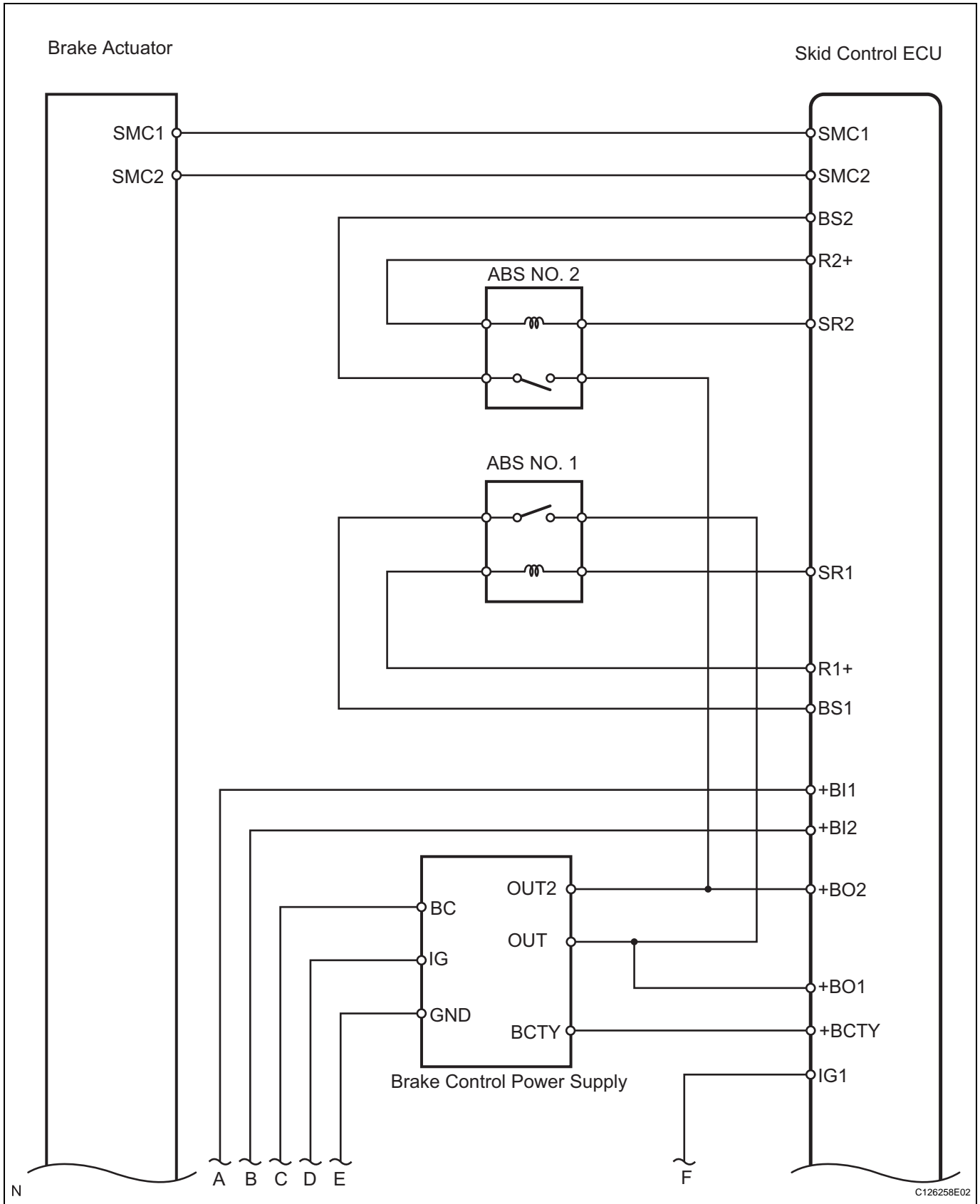

BC

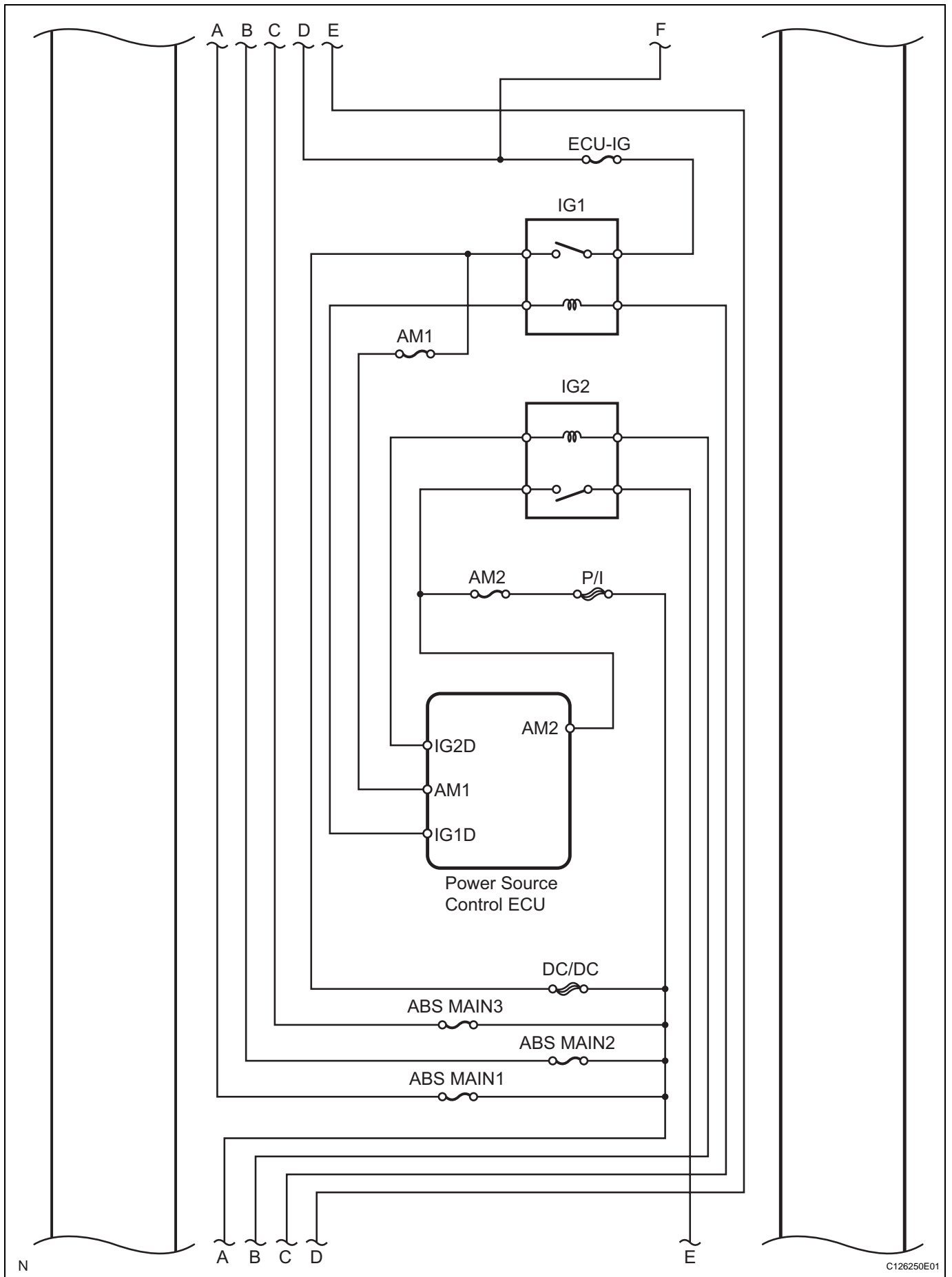

BC

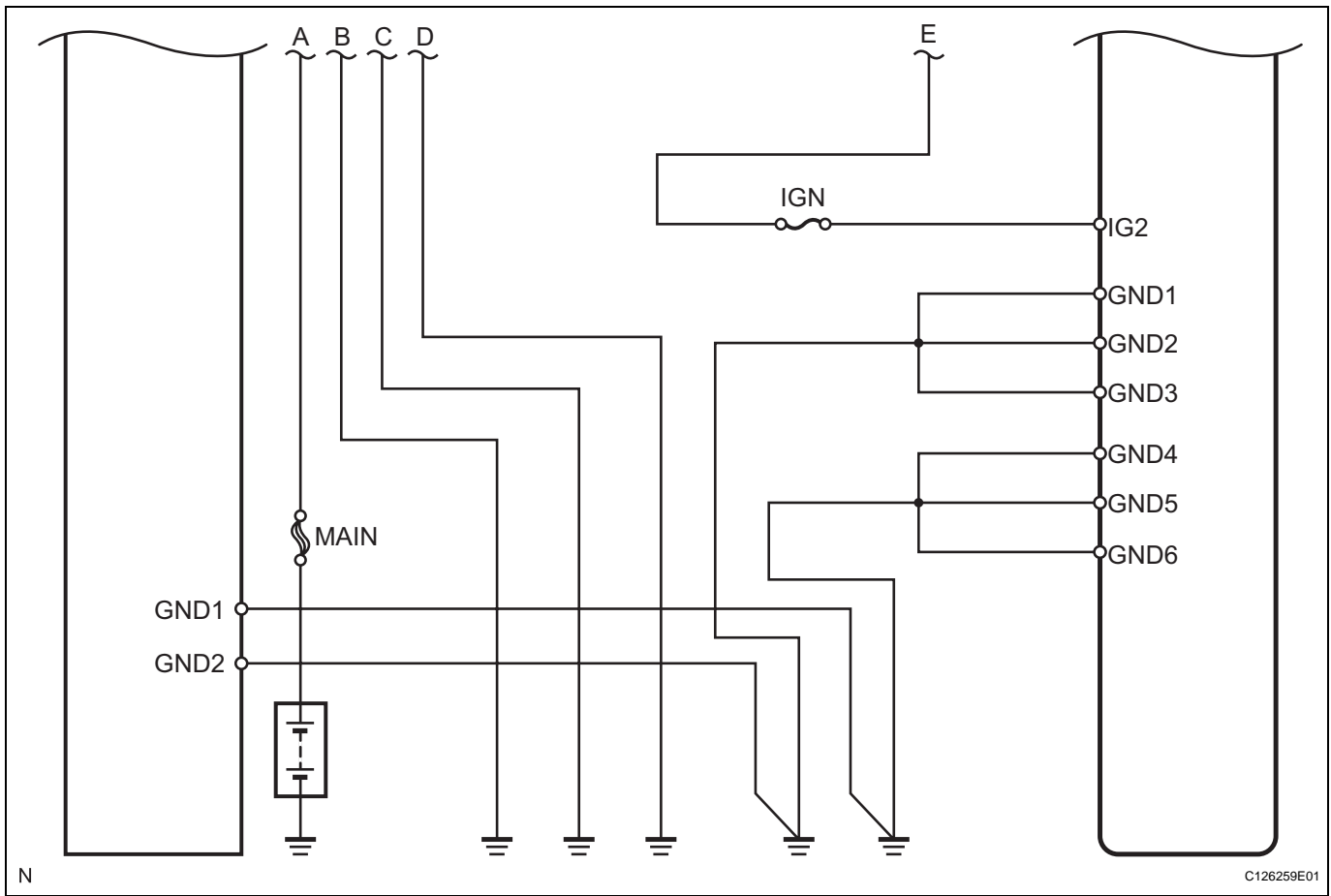

INSPECTION PROCEDURE

1 INSPECT FUSE (ABS MAIN3)

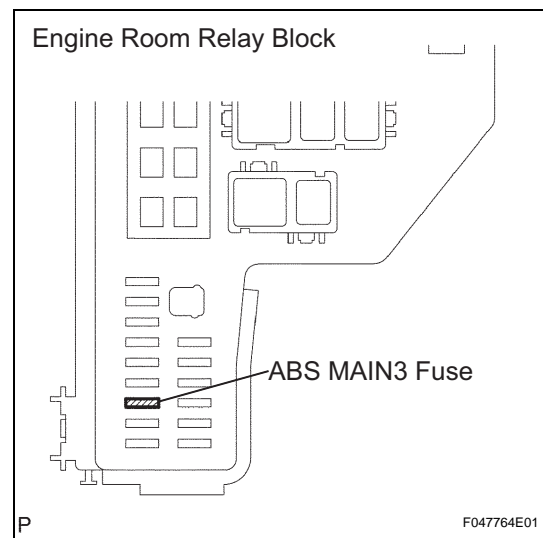

- (a) Remove the ABS MAIN3 fuse from the engine room relay block.
 - (b) Measure the resistance of the fuse.
- Standard resistance:**
Below 1 Ω

NG CHECK FOR SHORT IN ALL HARNESS AND CONNECTOR CONNECTED TO FUSE AND REPLACE FUSE

BC

OK

2 CHECK BRAKE CONTROL POWER SUPPLY (BC VOLTAGE)

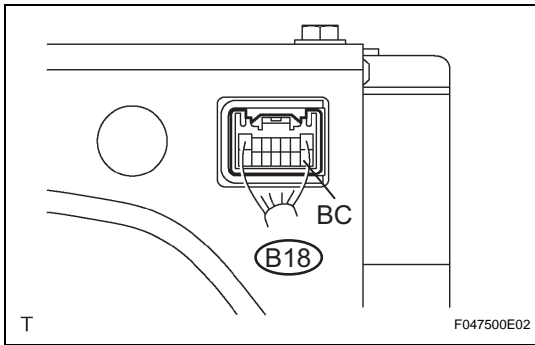

- (a) Measure the voltage of the connector.
 HINT:
 Measure the voltage from behind the connector with the connector connected.
Standard voltage

Tester Connection	Specified Condition
B18-8 (BC) - Body ground	10 to 14 V

NG REPAIR OR REPLACE HARNESS AND CONNECTOR

OK

3 CHECK SKID CONTROL ECU (+BI1, +BI2 VOLTAGE)

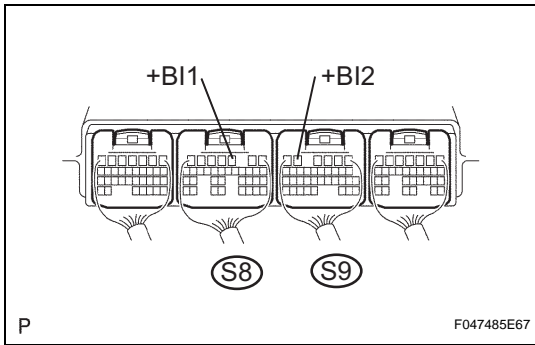

- (a) Measure the voltage of the connectors.
 HINT:
 Measure the voltage from behind the connector with the connector connected to the skid control ECU.
Standard voltage

Tester Connection	Specified Condition
S8-3 (+BI1) - Body ground	10 to 14 V
S9-5 (+BI2) - Body ground	10 to 14 V

NG REPAIR OR REPLACE HARNESS AND CONNECTOR

OK

4 CHECK SKID CONTROL ECU (+BO1, +BO2 VOLTAGE)

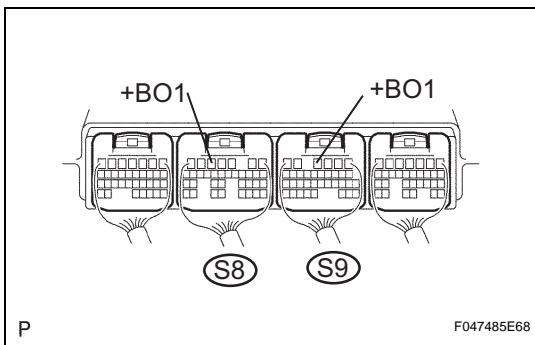

- (a) Measure the voltage of the connectors.
 HINT:
 Measure the voltage from behind the connector with the connector connected to the skid control ECU.
Standard voltage

Tester Connection	Specified Condition
S8-5 (+BO1) - Body ground	10 to 14 V
S9-4 (+BO2) - Body ground	10 to 14 V

NG REPAIR OR REPLACE HARNESS AND CONNECTOR

OK

5 CHECK BRAKE CONTROL POWER SUPPLY (OUT1, BCTY, OUT2 VOLTAGE)

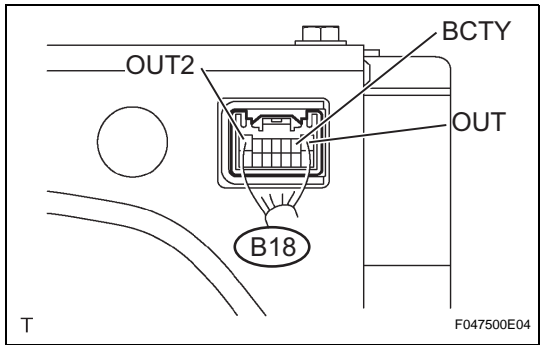

(a) Measure the voltage of the connector.

HINT:

Measure the voltage from behind the connector with the connector connected.

Standard voltage

Tester Connection	Condition	Specified Condition
B18-1 (OUT) - Body ground	Power switch ON (READY)	9 to 13 V
B18-2 (BCTY) - Body ground	Power switch ON (READY)	9 to 13 V
B18-7 (OUT2) - Body ground	Power switch ON (READY)	9 to 13 V

NG

REPLACE BRAKE CONTROL POWER SUPPLY

OK

REPAIR OR REPLACE HARNESS AND CONNECTOR

DTC**C1378/44****Capacitor Communication Malfunction****DESCRIPTION**

The brake control power supply assembly (capacitor) provides auxiliary power for brake control when an auxiliary battery (12 V) voltage drops.

The FAIL and ENA line are placed between the skid control ECU and the brake control power supply assembly. Signals indicating that the brake control power supply is in auxiliary mode are sent to the skid control ECU through the FAIL line.

Charge permit prohibition signals are sent to the brake control power supply through the ENA line.

DTC No.	INF Code	DTC Detection Condition	Trouble Area
C1378/44	112	When either condition below is met: <ul style="list-style-type: none"> • Open or short in FAIL line • Malfunction inside the power back up unit 	<ul style="list-style-type: none"> • Harness and connector • Skid control ECU
C1377/43	113	When either condition below is met: <ul style="list-style-type: none"> • Open or short in ENA line • Malfunction inside the skid control ECU (circuit for communication with the capacitor) 	<ul style="list-style-type: none"> • Harness and connector • Skid control ECU

WIRING DIAGRAM

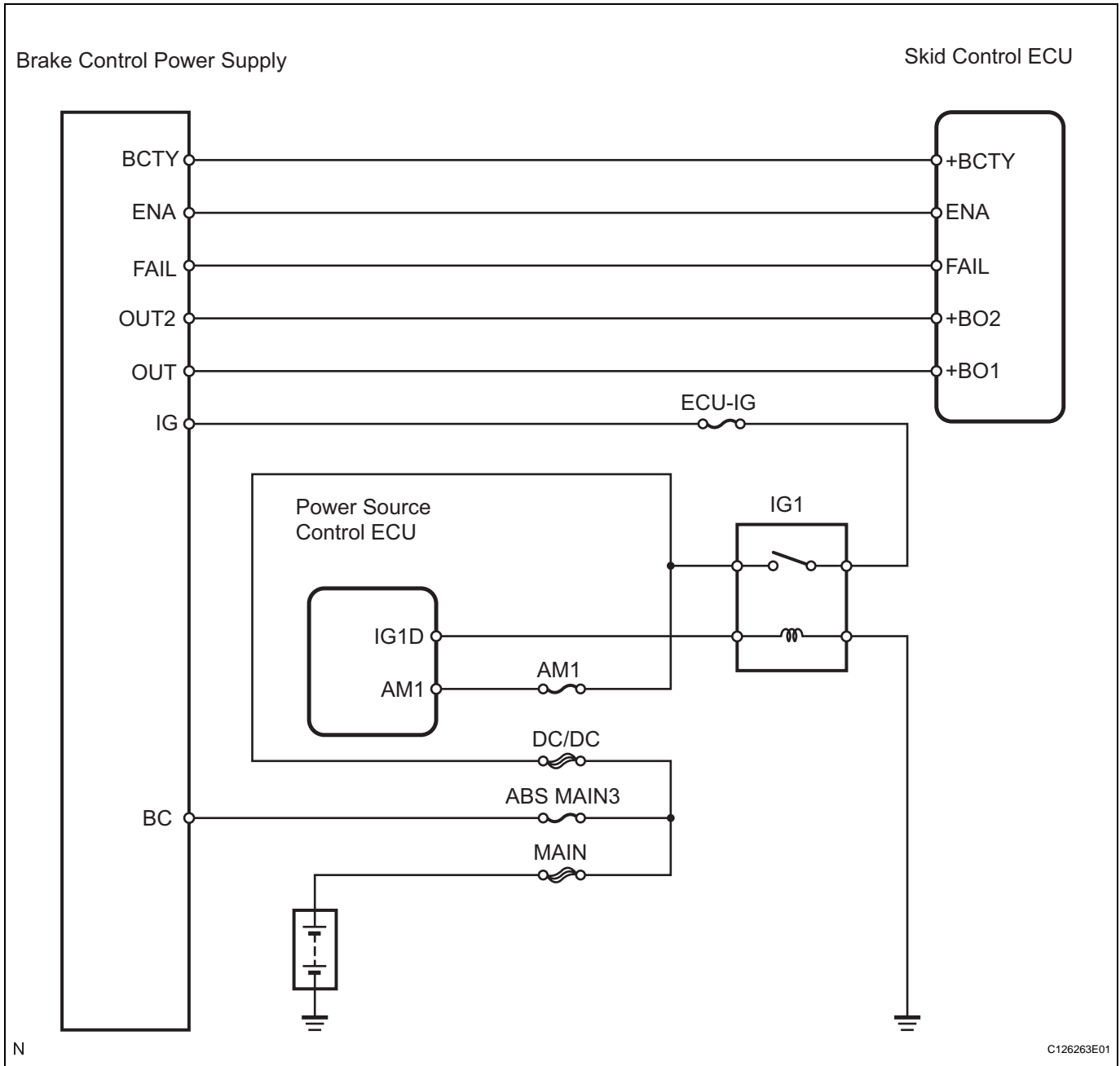

INSPECTION PROCEDURE

NOTICE:

BC When replacing the skid control ECU, perform initialization of linear solenoid valve and calibration (see page BC-19).

1 CHECK BRAKE CONTROL POWER SUPPLY (IG VOLTAGE)

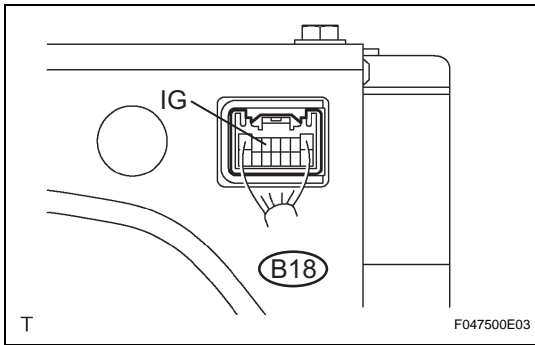

- (a) Measure the voltage of the connector.
- HINT:
Measure the voltage from behind the connector with the connector connected to the skid control ECU.

Standard voltage

Tester Connection	Condition	Specified Condition
B18-5 (IG) - Body ground	Power switch ON (READY)	10 to 14 V

NG REPAIR OR REPLACE HARNESS AND CONNECTOR

OK

2 CHECK WIRE HARNESS (SKID CONTROL ECU - BRAKE CONTROL POWER SUPPLY)

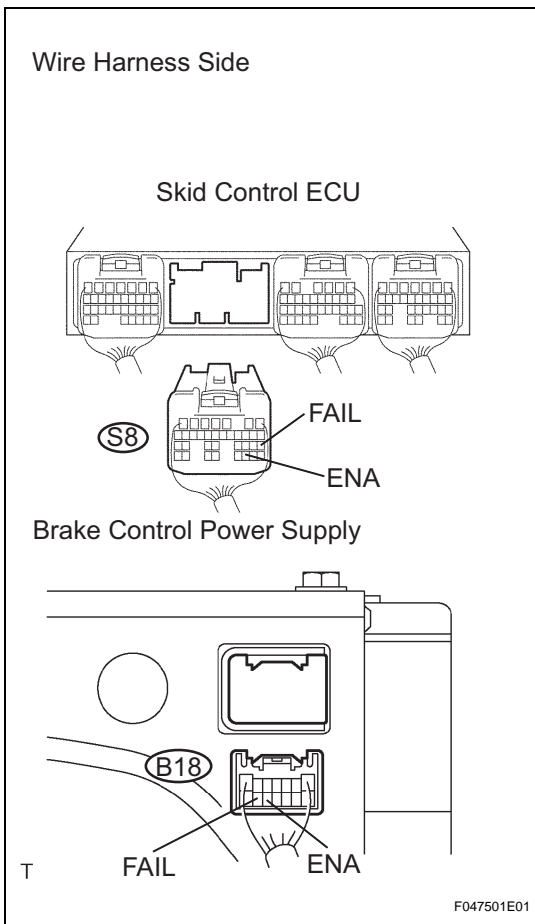

- (a) Disconnect the S8 ECU connector.
- (b) Disconnect the B18 supply connector.
- (c) Measure the resistance of the wire harness side connectors.

Standard resistance

Tester Connection	Specified Condition
S8-30 (ENA) - B18-12 (ENA)	Below 1 Ω
S8-20 (FAIL) - B18-13 (FAIL)	Below 1 Ω
S8-30 (ENA) - Body ground	10 kΩ or higher
S8-20 (FAIL) - Body ground	10 kΩ or higher

NG REPAIR OR REPLACE HARNESS AND CONNECTOR

OK

3 CHECK SKID CONTROL ECU (ENA, FAIL VOLTAGE)

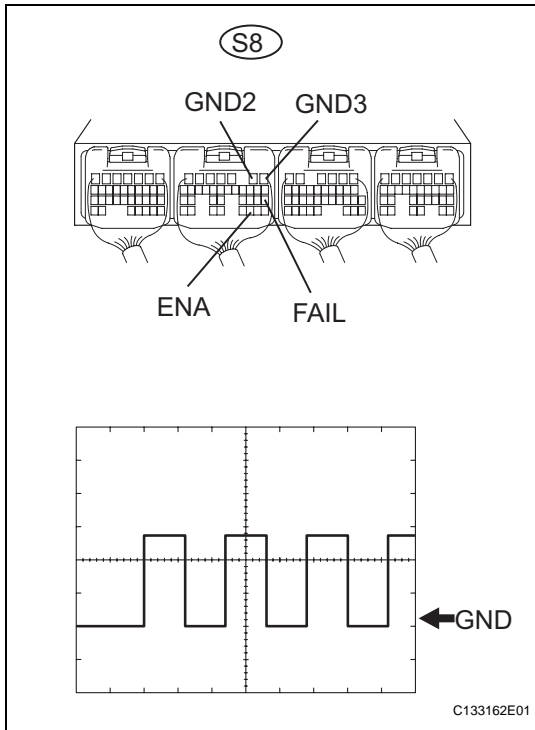

(a) Using an oscilloscope, check the waveform of the skid control ECU.

OK:

Waveform is output as shown in the illustration.

Waveform (FAIL)

Item	Content
Symbols (terminal No.)	S8-20 (FAIL) - S8-1, 2 (GND3, 2)
Tool Setting	5 V/DIV/., 200 ms/DIV.
Condition	Condition READY is displayed on the meter

Waveform (ENA)

Item	Content
Symbols (terminal No.)	S8-30 (ENA) - S8-1, 2 (GND3, 2)
Tool Setting	5 V/DIV/., 100 ms/DIV.
Condition	Condition READY is displayed on the meter

Result

Result	Proceed to
A	Both waveforms are normal
B	Waveform (ENA) is abnormal
C	Waveform (FAIL) is abnormal

B → **REPLACE BRAKE CONTROL POWER SUPPLY**

C → **REPLACE SKID CONTROL ECU**

A

REPLACE SKID CONTROL ECU

DTC	C1391/69	Accumulator Leak Malfunction
------------	-----------------	-------------------------------------

DESCRIPTION

HINT:

The DTC is stored if a brake fluid, internal or other leak is detected due to improper sealing in the actuator. Internal leakage is suspected if the pump motor operates frequently without braking.

DTC No.	INF Code	DTC Detection Condition	Trouble Area
C1391/69	591	Accumulation performance is deteriorated (improper sealing inside the actuator, gas pressure drop inside the accumulator, leak in each pressure boosting valve).	<ul style="list-style-type: none"> Fluid leakage Brake actuator assembly

INSPECTION PROCEDURE

NOTICE:

When replacing the skid control ECU, perform initialization of linear solenoid valve and calibration (see page [BC-19](#)).

1	CHECK BRAKE FLUID LEAKAGE
----------	----------------------------------

- (a) Check that there is no fluid leakage in the brake line between the brake actuator and the wheel cylinder which is the cause of DTCs.
- (b) Check that the brake is not dragging.

OK:

There is no fluid leakage or dragging.

NG REPAIR OR REPLACE APPLICABLE PART

OK

2	READ VALUE OF INTELLIGENT TESTER (ACCUMULATOR PRESSURE SENSOR)
----------	---

- (a) Check the DATA LIST for proper functioning of the accumulator pressure sensor.
- (b) Depress the brake pedal 4 or 5 times to operate the pump motor, and check the output value on the intelligent tester with the motor and check the output value on the intelligent tester with the motor stopped (no braking).

Skid control ECU

Item	Measurement Item / Range (Display)	Normal Condition	Diagnostic Note
ACC PRESS SENS 1	Accumulator pressure sensor 1 / Min.: 0 V, Max.: 5 V	Specified value: 3.2 to 4.0 V	-

OK:

Accumulator pressure sensor voltage does not drop.

NG REPLACE BRAKE ACTUATOR ASSEMBLY

OK

REPLACE SKID CONTROL ECU

ABS Warning Light Remains ON**DESCRIPTION**

The ABS warning light illuminates to inform the driver that there is a problem in the ABS. When DTC output is normal and the ABS warning light remains on, perform troubleshooting as indicated below.

WIRING DIAGRAM

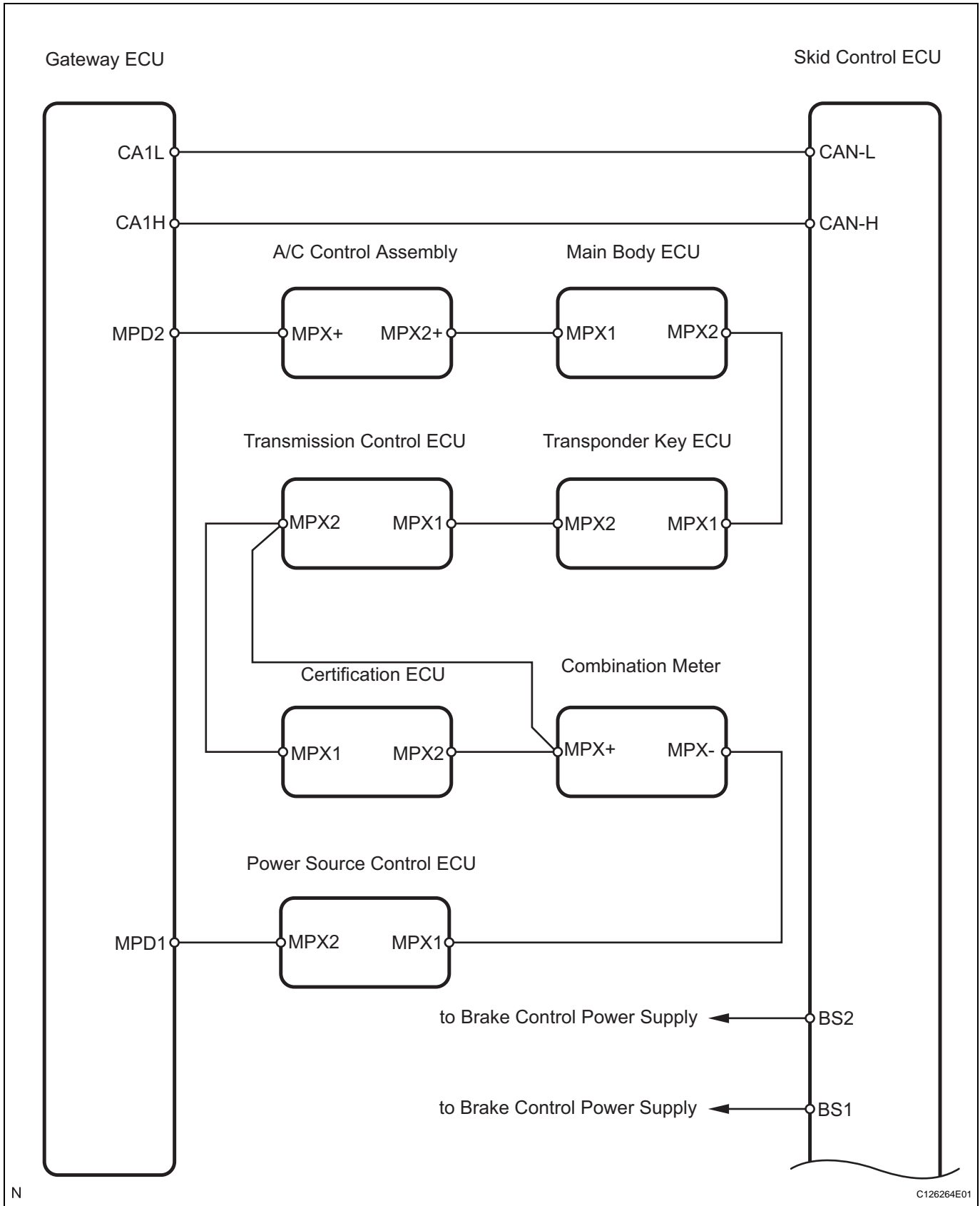

BC

N

C126264E01

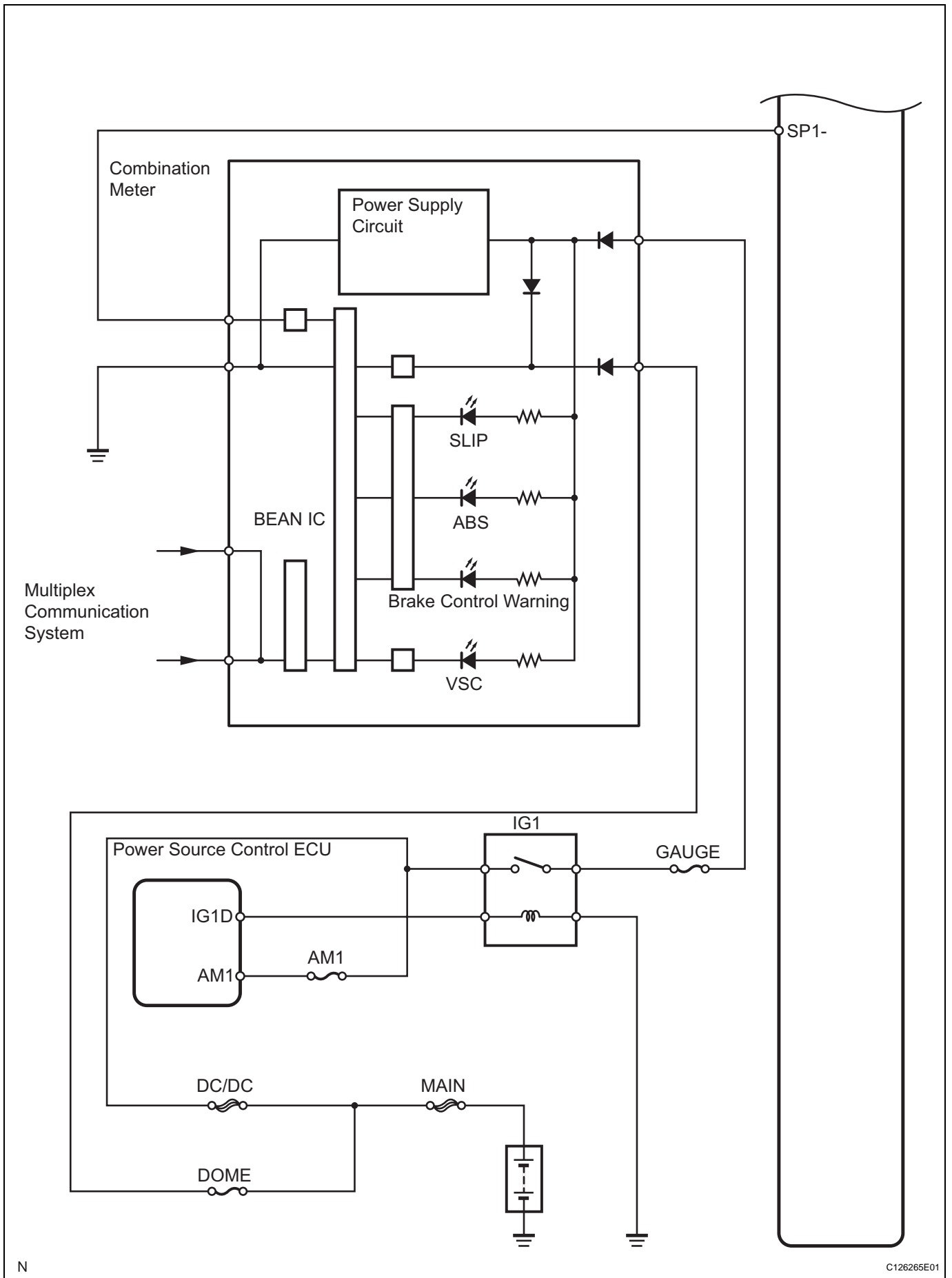

BC

INSPECTION PROCEDURE

NOTICE:

When replacing the skid control ECU, perform initialization of linear solenoid valve and calibration (see page [BC-19](#)).

1 CHECK SKID CONTROL ECU (BS1, BS2 VOLTAGE)

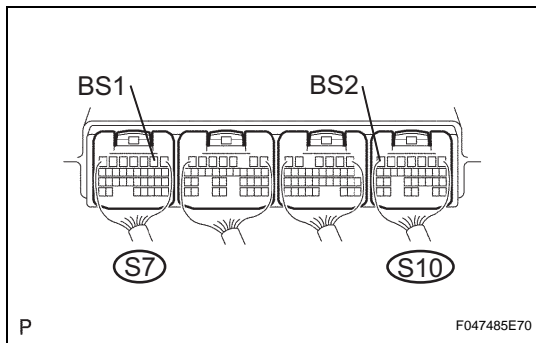

- (a) Measure the voltage of the connectors.

HINT:

Measure the voltage from behind the connector with the connector connected to the skid control ECU.

Standard voltage

Tester Connection	Specified Condition
S7-3 (BS1) - Body ground	10 to 14 V
S10-7 (BS2) - Body ground	10 to 14 V

NG

REPAIR OR REPLACE HARNESS AND CONNECTOR

OK

2 PERFORM ACTIVE TEST BY INTELLIGENT TESTER (ABS WARNING LIGHT)

- (a) Select the ACTIVE TEST, generate a control command, and then check that the ABS warning light operates.

Skid control ECU

Item	Test Details	Diagnostic Note
ABS WARN LIGHT	Turns ABS warning light ON / OFF	Observe combination meter

OK:

The ABS warning light turns on or off.

NG

REPAIR OR REPLACE COMBINATION METER ASSEMBLY

OK

REPLACE SKID CONTROL ECU

ABS Warning Light does not Come ON**INSPECTION PROCEDURE****1 CHECK CAN COMMUNICATION SYSTEM**

- (a) Check if a CAN communication system DTC is output (see page [CA-16](#)).

Result

Result	Proceed to
DTC is not output	A
DTC is output	B

B**REPAIR CAN COMMUNICATION SYSTEM****A****2 CHECK MULTIPLEX COMMUNICATION SYSTEM**

- (a) Check if a multiplex communication system DTC is output (see page [MP-7](#)).

Result

Result	Proceed to
DTC is not output	A
DTC is output	B

B**REPAIR MULTIPLEX COMMUNICATION SYSTEM****A****REPAIR OR REPLACE COMBINATION METER ASSEMBLY**

VSC Warning Light Remains ON**DESCRIPTION**

The VSC warning light illuminates to inform the driver that there is a problem in the Enhanced VSC. When DTC output is normal and the VSC warning light remains on, perform troubleshooting as indicated below.

WIRING DIAGRAM

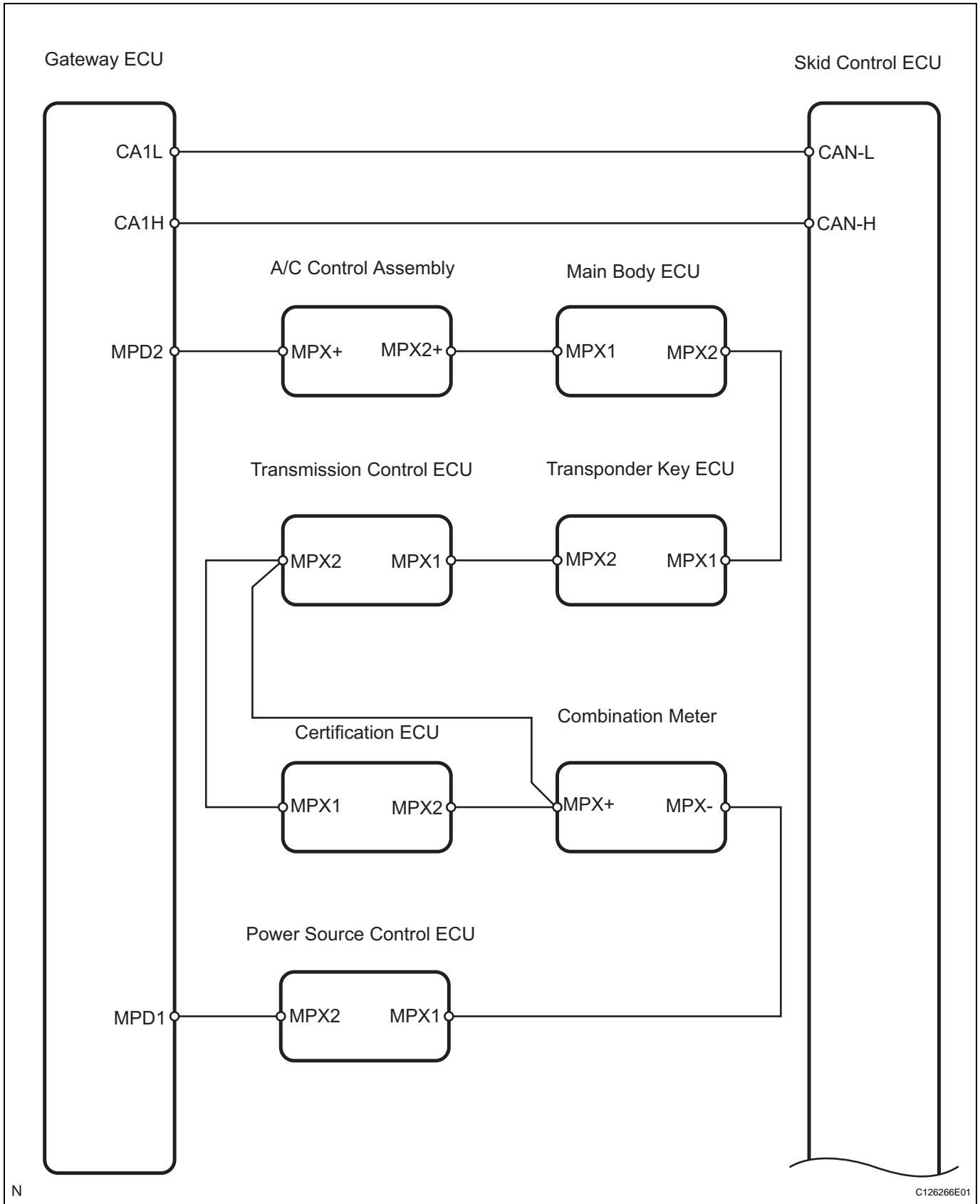

BC

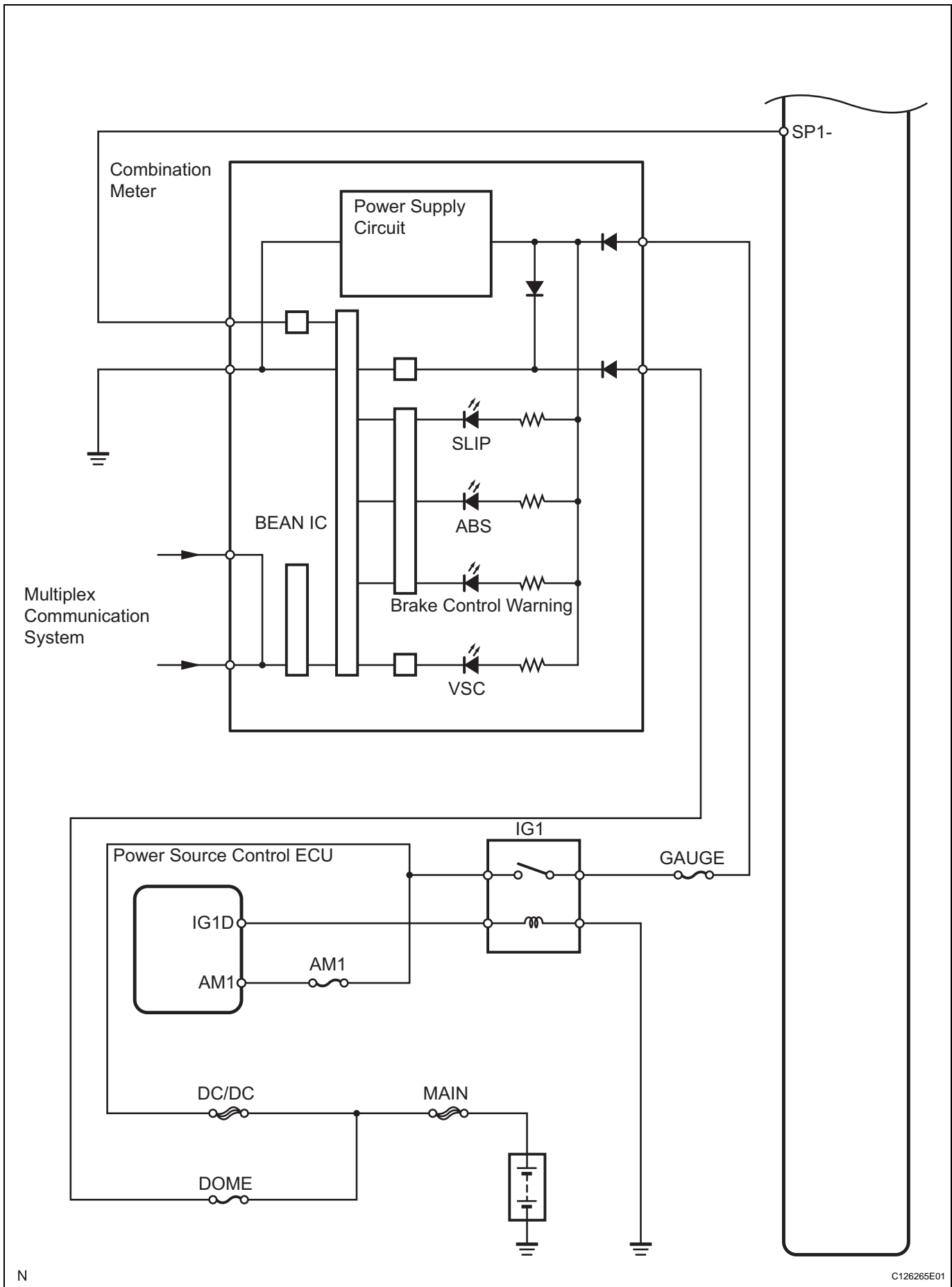

BC

INSPECTION PROCEDURE**NOTICE:**

When replacing the skid control ECU, perform initialization of linear solenoid valve and calibration (see page [BC-19](#)).

1 CHECK SKID CONTROL ECU CONNECTOR

- (a) Check the skid control ECU connector's connecting condition.

OK:

The connector should be securely connected.

NG

**CONNECT CONNECTOR TO ECU
CORRECTLY**

OK**2 PERFORM ACTIVE TEST BY INTELLIGENT TESTER (VSC WARNING LIGHT)**

- (a) Select the ACTIVE TEST, generate a control command, and then check that the VSC warning light operates.

Skid control ECU

Item	Test Details	Diagnostic Note
VSC WARN LIGHT	Turns VSC warning light ON / OFF	Observe combination meter

OK:

The VSC warning light turns on or off.

NG

**REPAIR OR REPLACE COMBINATION
METER ASSEMBLY**

OK**REPLACE SKID CONTROL ECU**

VSC Warning Light does not Come ON

INSPECTION PROCEDURE

1 CHECK CAN COMMUNICATION SYSTEM

- (a) Check if a CAN communication system DTC is output (see page [CA-16](#)).

Result

Result	Proceed to
DTC is not output	A
DTC is output	B

B

REPAIR CAN COMMUNICATION SYSTEM

A

2 CHECK MULTIPLEX COMMUNICATION SYSTEM

- (a) Check if a multiplex communication system DTC is output (see page [MP-7](#)).

Result

Result	Proceed to
DTC is not output	A
DTC is output	B

B

REPAIR MULTIPLEX COMMUNICATION SYSTEM

A

REPAIR OR REPLACE COMBINATION METER ASSEMBLY

Brake Warning Light Circuit

DESCRIPTION

The BRAKE warning light comes on when the brake fluid is insufficient or the parking brake is applied. The skid control ECU is connected to the combination meter via the CAN and multiplex communications. When the DTC is normal and BRAKE warning light remains on, perform troubleshooting as indicated below.

WIRING DIAGRAM

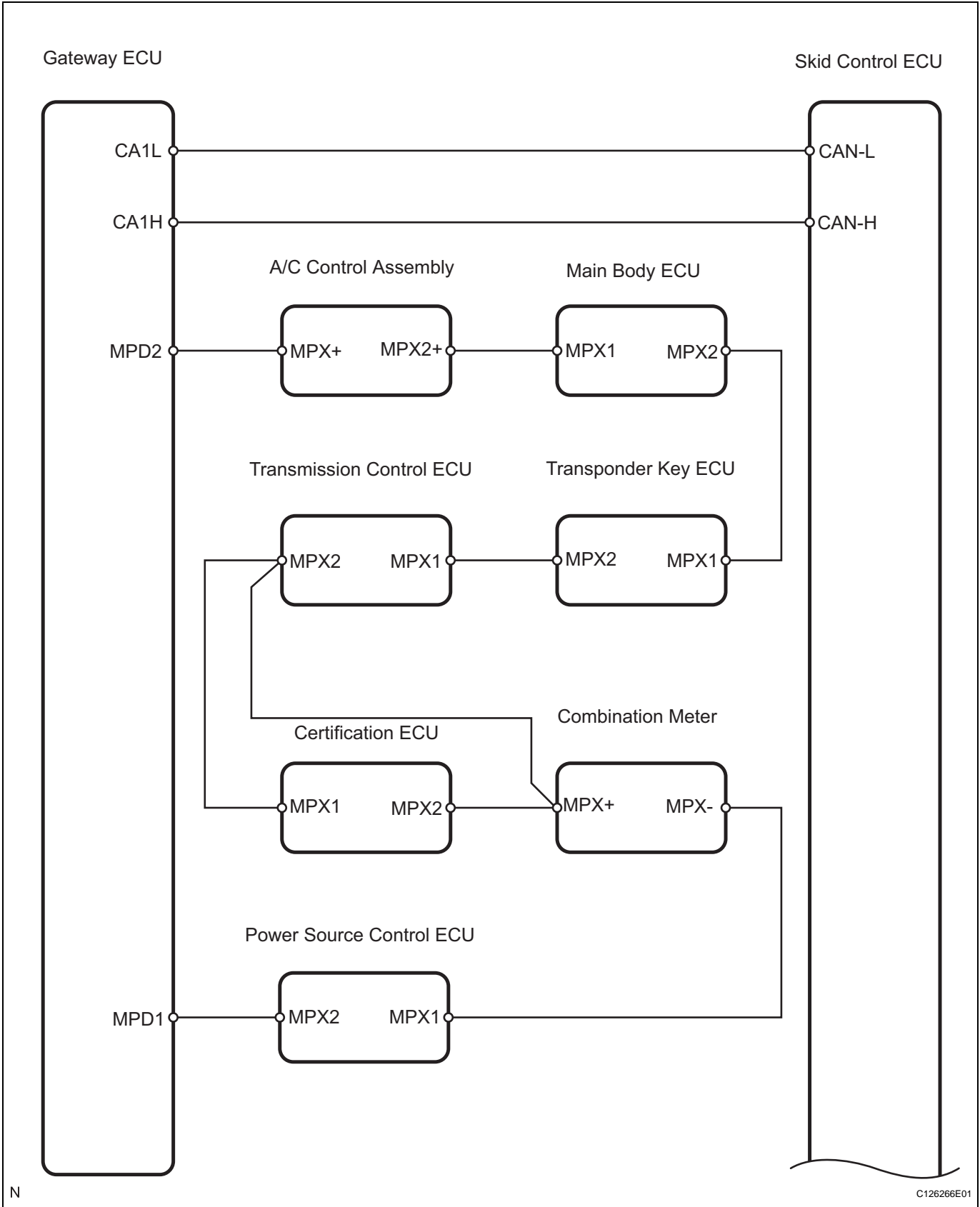

BC

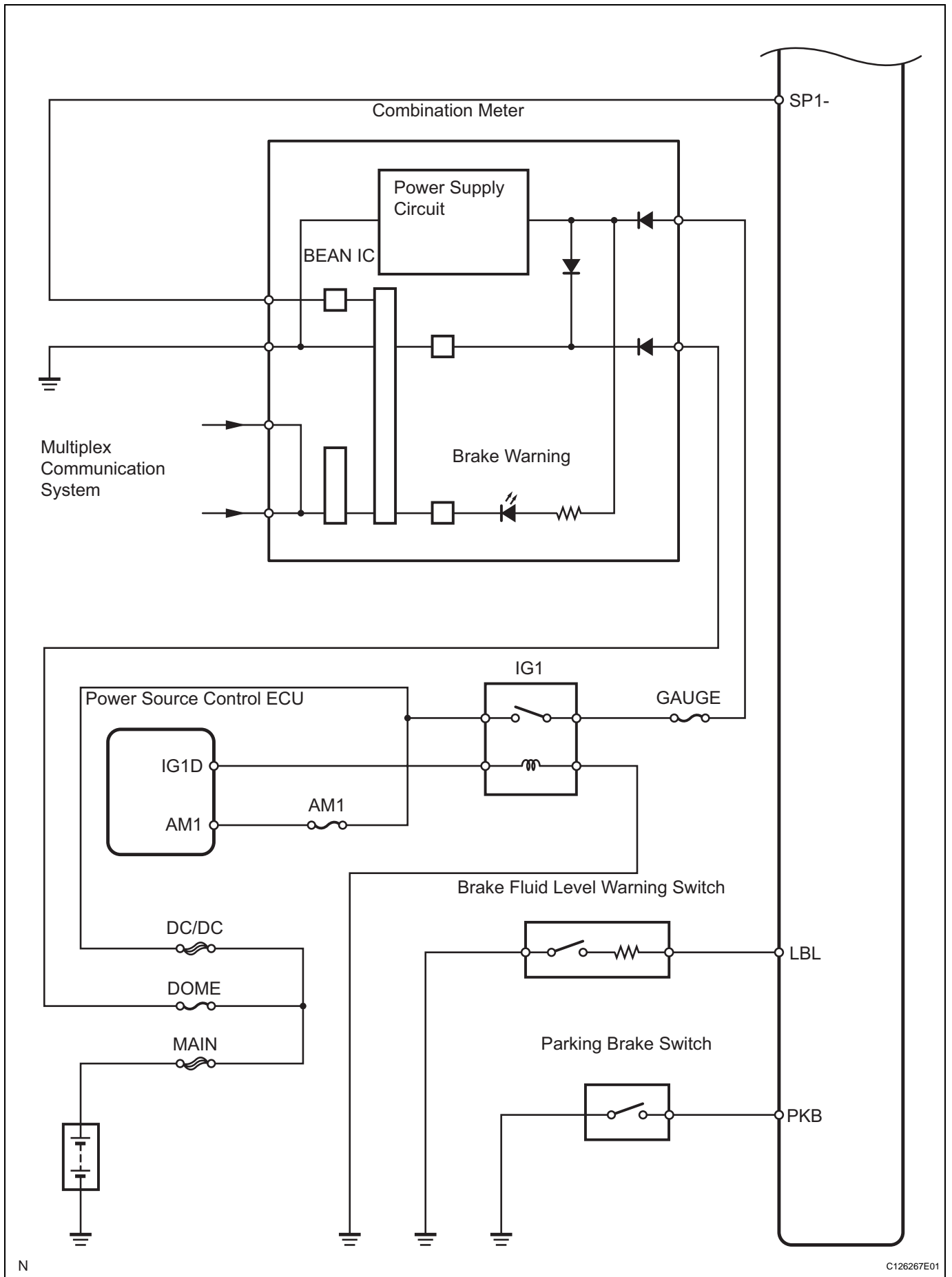

BC

INSPECTION PROCEDURE

NOTICE:

When replacing the skid control ECU, perform initialization of linear solenoid valve and calibration (see page [BC-19](#)).

1 CHECK BRAKE FLUID LEVEL IN RESERVOIR

- (a) Check that the brake fluid level is sufficient.

HINT:

- If the fluid level drops, check for a fluid leak, and repair if found.
- If no leaks exist, add and adjust fluid and then check that the trouble code is not output again.

OK:

Brake fluid level is proper.

NG

ADD BRAKE FLUID

OK

2 CHECK DTC FOR ABS

Check if the DTCs are recorded (see page [BC-38](#)).

OK

REPAIR CIRCUIT INDICATED BY OUTPUT CODE

NG

3 INSPECT PARKING BRAKE SWITCH ASSEMBLY

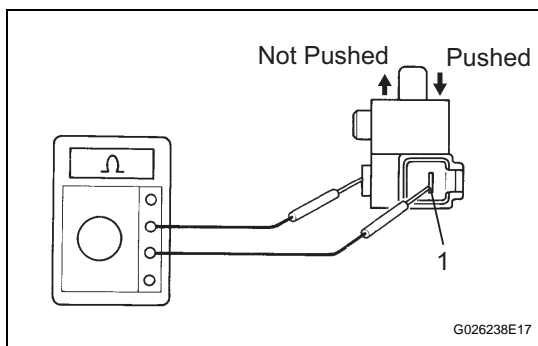

- (a) Remove the parking brake switch connector.
 (b) Measure the resistance of the switch.

Standard resistance

Tester Connection	Switch Condition	Specified Condition
P2-1 - Ground part	Not pushed	Below 1 Ω
P2-1 - Ground part	Pushed	10 k Ω or higher

NG

REPLACE PARKING BRAKE SWITCH ASSEMBLY

OK

4 CHECK WIRE HARNESS (SKID CONTROL ECU - PARKING BRAKE SWITCH)

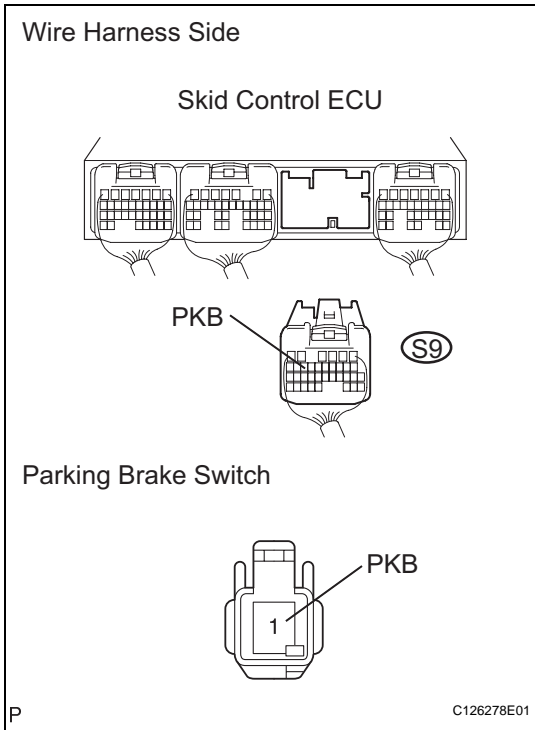

- (a) Disconnect the S9 ECU connector.
- (b) Disconnect the P3 switch connector.
- (c) Measure the resistance of the wire harness side connectors.

Standard resistance

Tester Connection	Specified Condition
S9-14 (PKB) - P3-1 (PKB)	Below 1 Ω
S9-14 (PKB) - Body ground	10 kΩ or higher

NG REPAIR OR REPLACE HARNESS AND CONNECTOR

OK

5 INSPECT BRAKE FLUID LEVEL WARNING SWITCH

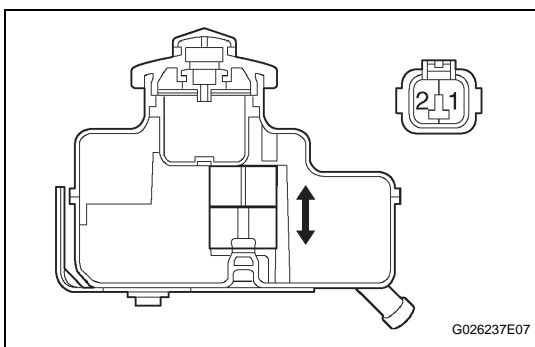

- (a) Remove the reservoir tank cap and strainer.
- (b) Disconnect the brake fluid level warning switch connector.
- (c) Measure the resistance of the switch.

Standard resistance

Tester Connection	Fluid Level	Specified Condition
1 - 2	Proper	1.8 to 2.16 kΩ
1 - 2	Below minimum level	10 kΩ or higher

NG REPLACE BRAKE FLUID LEVEL WARNING SWITCH

OK

6 INSPECT SKID CONTROL ECU CONNECTOR

- (a) Check the skid control ECU connector's connecting condition.

OK:

The connector should be securely connected.

NG CONNECT CONNECTOR TO ECU CORRECTLY

OK

7 | PERFORM ACTIVE TEST BY INTELLIGENT TESTER (BRAKE WARNING LIGHT)

- (a) Select the ACTIVE TEST, generate a control command, and then check that the brake warning light operates.

Skid control ECU

Item	Test Details	Diagnostic Note
BRAKE WARN LIGHT	Turns BRAKE warning light ON / OFF	Observe combination meter

OK:

The brake warning light turns on or off.

NG

REPAIR OR REPLACE COMBINATION METER ASSEMBLY

OK

REPLACE SKID CONTROL ECU

Brake Control Warning Light Remains ON**DESCRIPTION**

The skid control ECU is connected to the combination meter via the CAN and multiplex communications. The brake control warning light illuminates to inform the driver that there is a problem in the ECB, or a problem in the brake system that has no influence on driving.

WIRING DIAGRAM

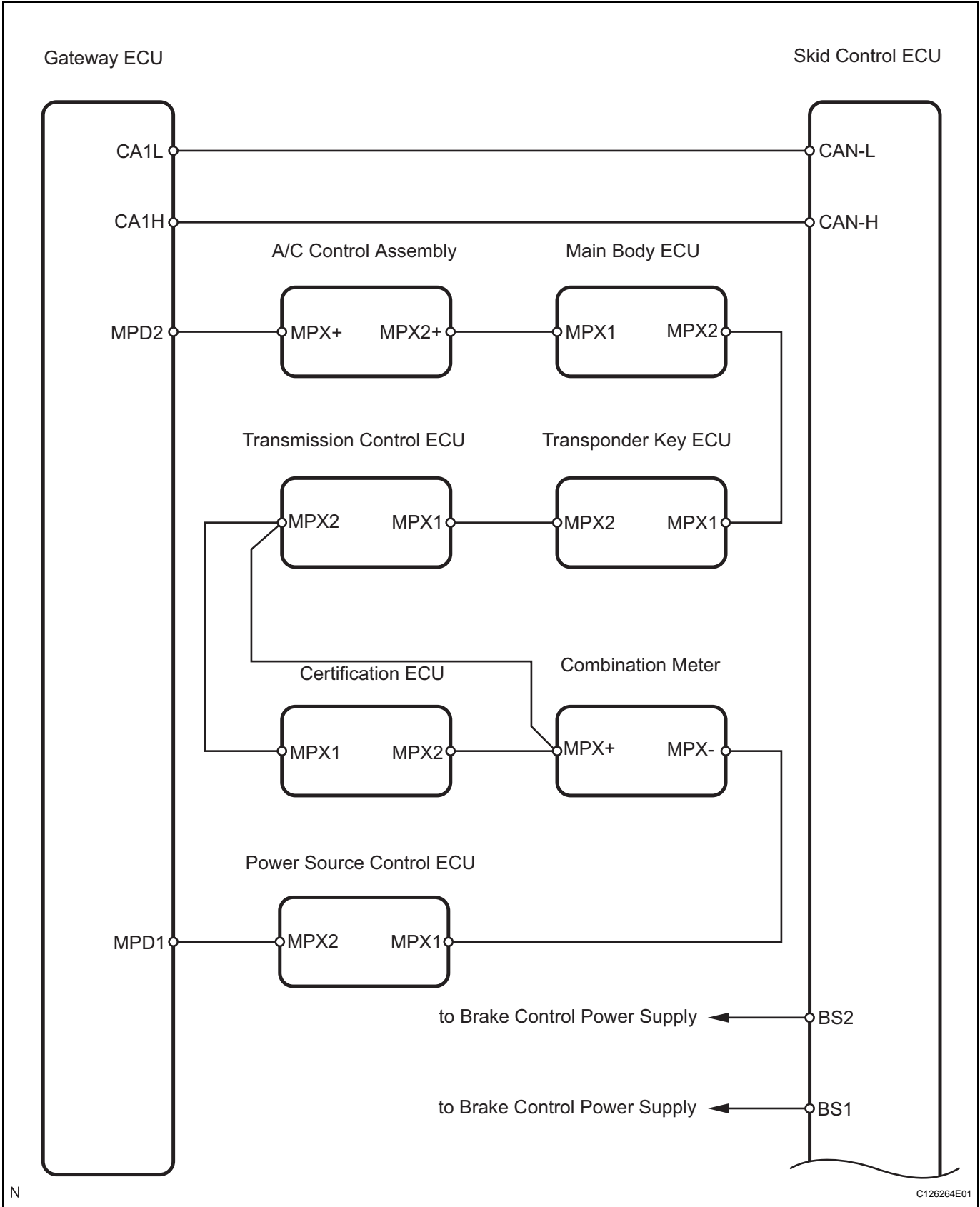

BC

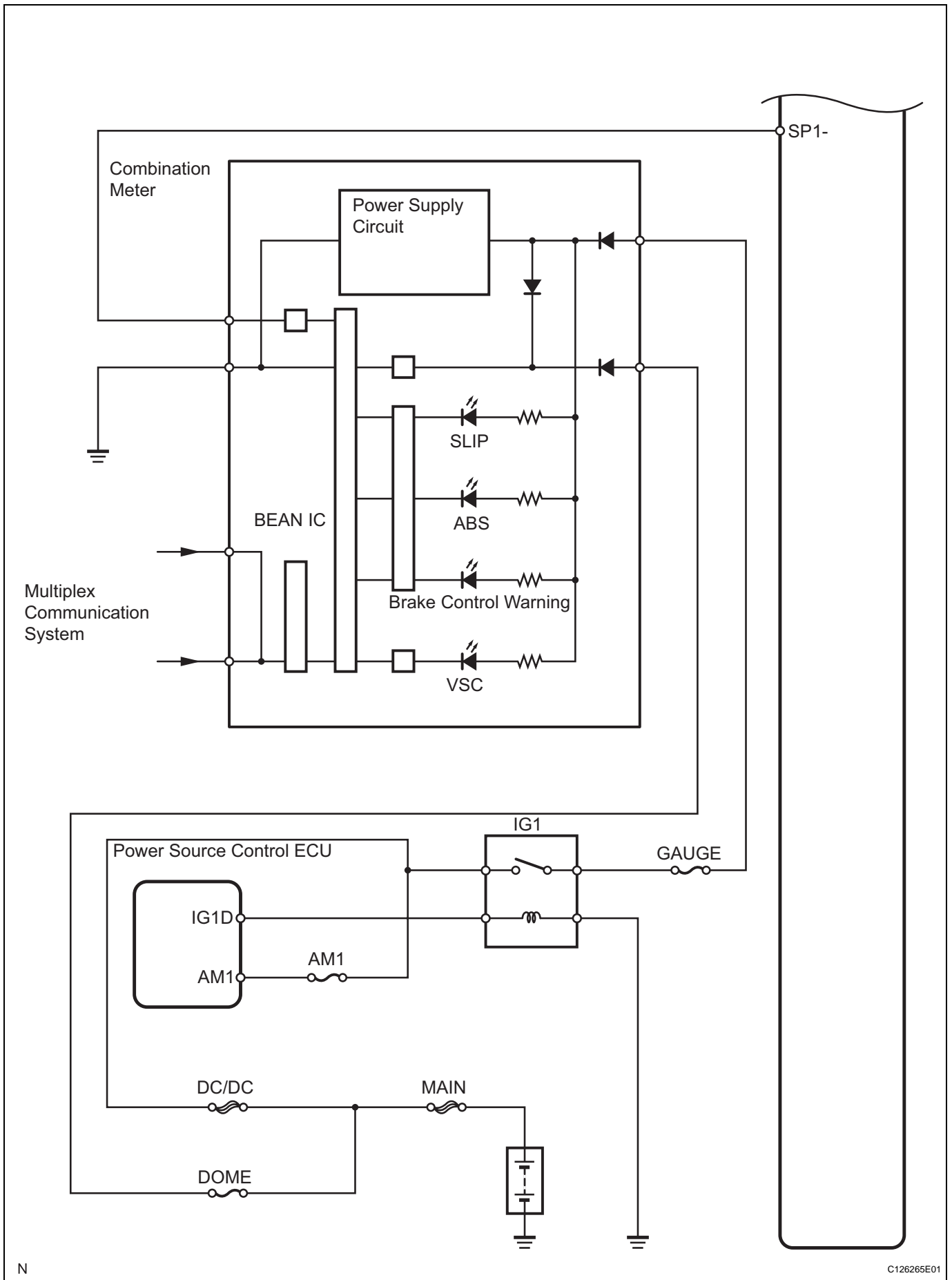

BC

INSPECTION PROCEDURE

NOTICE:

When replacing the skid control ECU, perform initialization of linear solenoid valve and calibration (see page [BC-19](#)).

1 CHECK SKID CONTROL ECU (BS1, BS2 VOLTAGE)

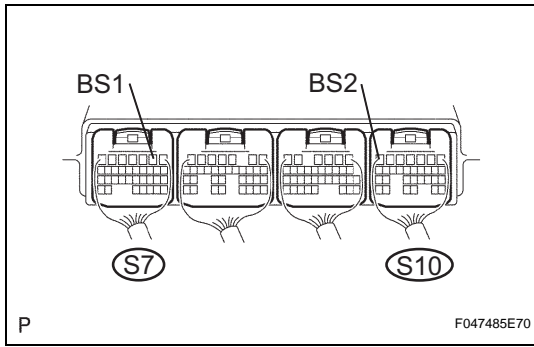

(a) Measure the voltage of the connectors.

HINT:

Measure the voltage from behind the connector with the connector connected to the skid control ECU.

Tester Connection	Specified Condition
S7-3 (BS1) - Body ground	10 to 14 V
S10-7 (BS2) - Body ground	10 to 14 V

NG

REPAIR OR REPLACE HARNESS AND CONNECTOR

OK

2 PERFORM ACTIVE TEST BY INTELLIGENT TESTER (BRAKE CONTROL WARNING LIGHT)

(a) Select the ACTIVE TEST, generate a control command, and then check that the brake control warning light operates.

Skid control ECU

Item	Test Details	Diagnostic Note
ECB INDI LIGHT	Turns Brake Control warning light ON / OFF	Observe combination meter

OK:

The brake control warning light turns on or off.

NG

REPAIR OR REPLACE COMBINATION METER

OK

REPLACE SKID CONTROL ECU

Brake Control Warning Light does not Come ON

INSPECTION PROCEDURE

1 CHECK CAN COMMUNICATION SYSTEM

- (a) Check if a CAN communication system DTC is output (see page [CA-6](#)).

Result

Result	Proceed to
DTC is not output	A
DTC is output	B

B

REPAIR CAN COMMUNICATION SYSTEM

A

2 CHECK MULTIPLEX COMMUNICATION SYSTEM

- (a) Check if a multiplex communication system DTC is output (see page [MP-7](#)).

Result

Result	Proceed to
DTC is not output	A
DTC is output	B

B

REPAIR MULTIPLEX COMMUNICATION SYSTEM

A

REPAIR OR REPLACE COMBINATION METER ASSEMBLY

Slip Indicator Light Circuit

DESCRIPTION

The SLIP indicator blinks during Enhanced VSC operation.

The skid control ECU is connected to the combination meter via the CAN and multiplex communications.

WIRING DIAGRAM

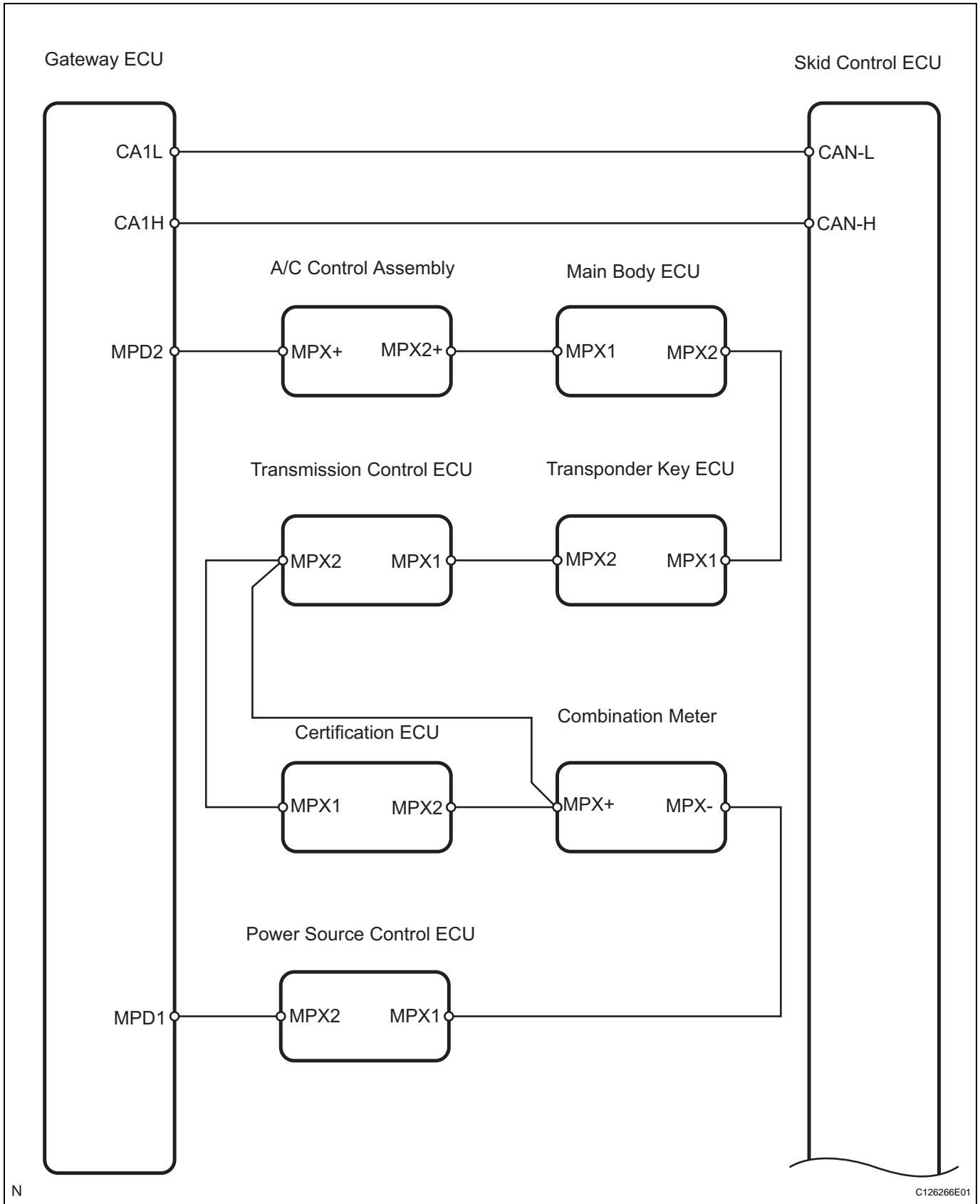

BC

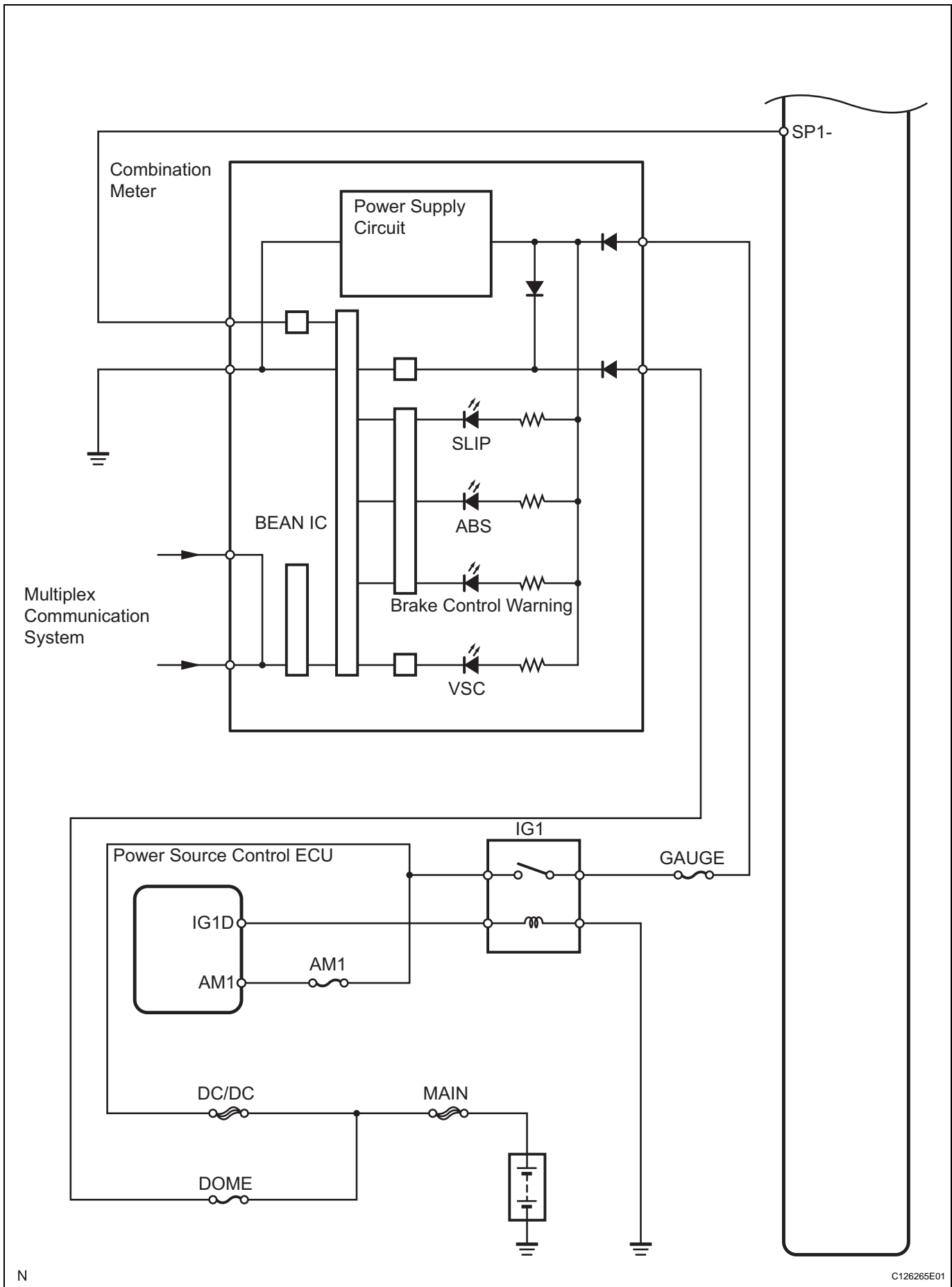

BC

INSPECTION PROCEDURE**NOTICE:**

When replacing the skid control ECU, perform initialization of linear solenoid valve and calibration (see page [BC-19](#)).

1 PERFORM ACTIVE TEST BY INTELLIGENT TESTER (SLIP INDICATOR LIGHT)

- (a) Select the ACTIVE TEST, generate a control command, and then check that the SLIP indicator light operates.

Skid control ECU

Item	Test Details	Diagnostic Note
SLIP INDI LIGHT	Turns SLIP indicator light ON / OFF	Observe combination meter

OK:

Turn the SLIP indicator light on or off.

OK

REPLACE SKID CONTROL ECU

NG

2 CHECK CAN COMMUNICATION SYSTEM

- (a) Check if a CAN communication system DTC is output (see page [CA-16](#)).

Result

Result	Proceed to
DTC is not output	A
DTC is output	B

B

REPAIR CAN COMMUNICATION SYSTEM

A

3 CHECK MULTIPLEX COMMUNICATION SYSTEM

- (a) Check if a multiplex communication system DTC is output.

Result

Result	Proceed to
DTC is not output	A
DTC is output	B

B

REPAIR MULTIPLEX COMMUNICATION SYSTEM

A

REPAIR OR REPLACE COMBINATION METER ASSEMBLY

Skid Control Buzzer Circuit

DESCRIPTION

The skid control buzzer sounds and VSC warning light comes ON during Enhanced VSC operation.

WIRING DIAGRAM

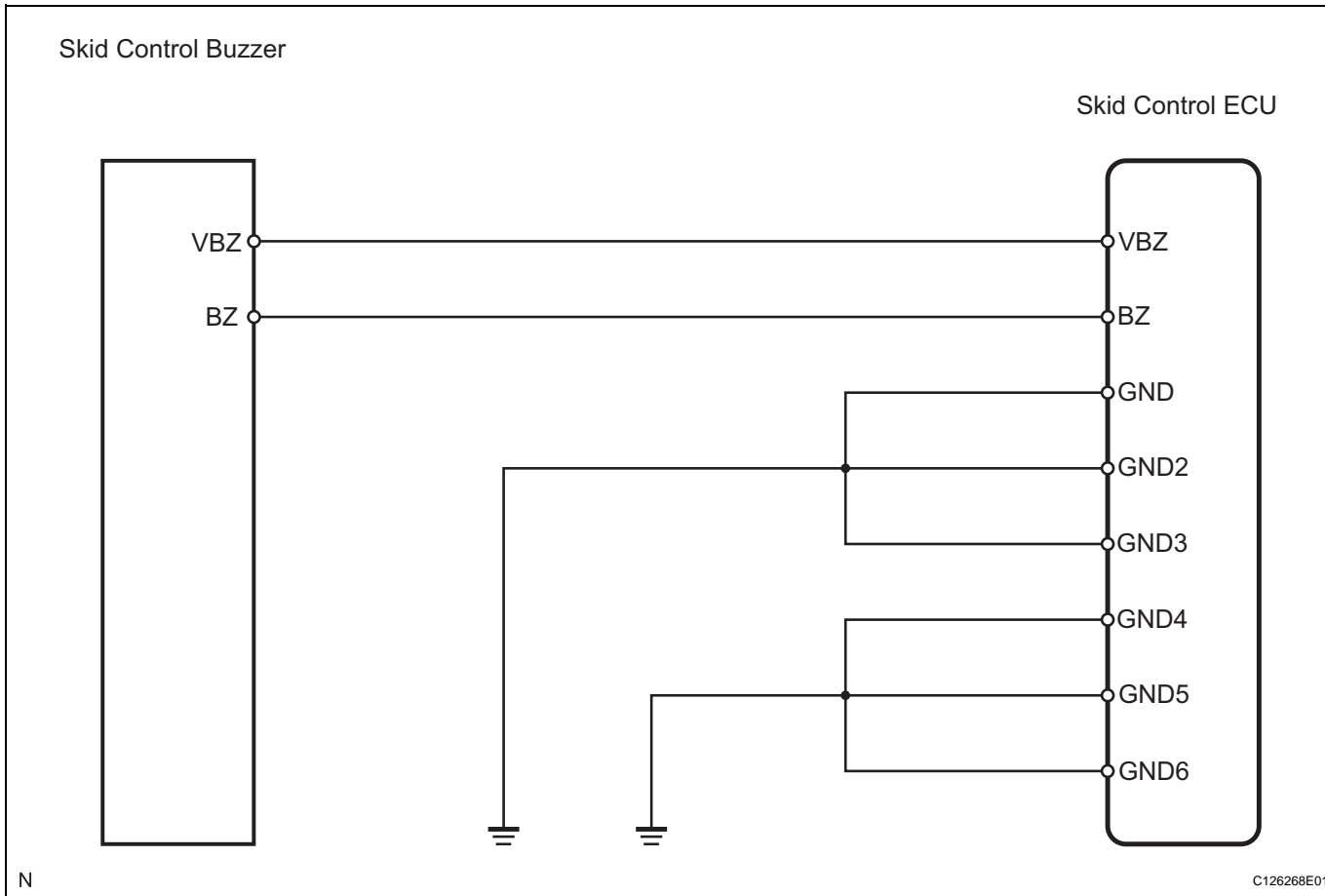

INSPECTION PROCEDURE

NOTICE:

When replacing the skid control ECU, perform initialization of linear solenoid valve and calibration (see page BC-19).

1 PERFORM ACTIVE TEST BY INTELLIGENT TESTER (SKID CONTROL BUZZER)

- (a) Select the ACTIVE TEST, generate a control command, and then check that the skid control buzzer operates.

Skid control ECU

Item	Test Details	Diagnostic Note
VSC/BR WARN BUZ	Turns VSC / BRAKE warning buzzer ON / OFF	Buzzer can be heard

OK:

The skid control buzzer can be heard.

OK

REPLACE SKID CONTROL ECU

NG

2 INSPECT SKID CONTROL BUZZER ASSEMBLY

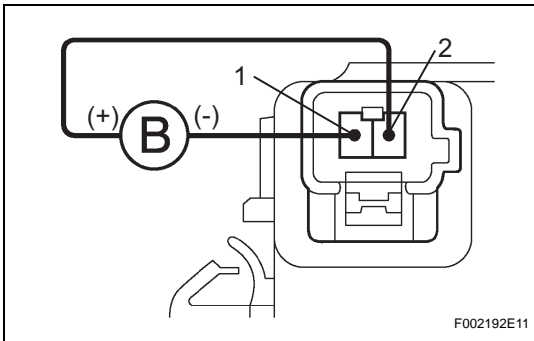

- (a) Disconnect the skid control buzzer connector.
- (b) Apply a battery positive voltage to terminals 1 and 2 of the skid control buzzer connector, and check that the buzzer sounds.

OK:

The skid control buzzer sound should be heard.

NG

REPLACE SKID CONTROL BUZZER ASSEMBLY

OK

3 CHECK WIRE HARNESS (SKID CONTROL ECU - SKID CONTROL BUZZER)

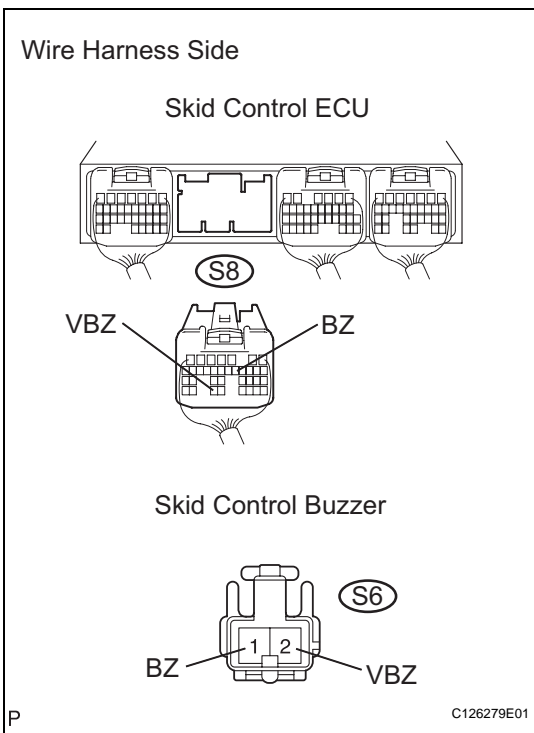

- (a) Disconnect the S8 ECU connector.
- (b) Disconnect the S6 buzzer connectors.
- (c) Measure the resistance of the wire harness side connectors.

Standard resistance

Tester Connection	Specified Condition
S8-33 (VBZ) - S6-2 (VBZ)	Below 1 Ω
S8-12 (BZ) - S6-1 (BZ)	Below 1 Ω
S8-33 (VBZ) - Body ground	10 kΩ or higher
S8-12 (BZ) - Body ground	10 kΩ or higher

NG

REPAIR OR REPLACE HARNESS AND CONNECTOR

OK

4 CHECK WIRE HARNESS (SKID CONTROL ECU - BODY GROUND)

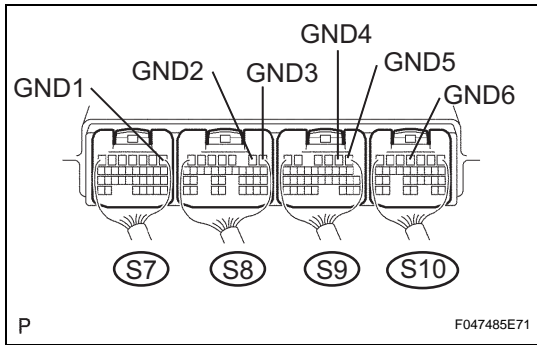

(a) Measure the resistance of the connectors.

Standard resistance

Tester Connection	Specified Condition
S7-1 (GND1) - Body ground	Below 1 Ω
S8-2 (GND2) - Body ground	Below 1 Ω
S8-1 (GND3) - Body ground	Below 1 Ω
S9-2 (GND4) - Body ground	Below 1 Ω
S9-1 (GND5) - Body ground	Below 1 Ω
S10-4 (GND6) - Body ground	Below 1 Ω

NG

REPAIR OR REPLACE HARNESS AND CONNECTOR

OK

REPLACE SKID CONTROL ECU ASSEMBLY

TC and CG Terminal Circuit

DESCRIPTION

Connecting terminals TC and CG of the DLC3 causes the ECU to display DTCs by flashing the ABS warning light.

WIRING DIAGRAM

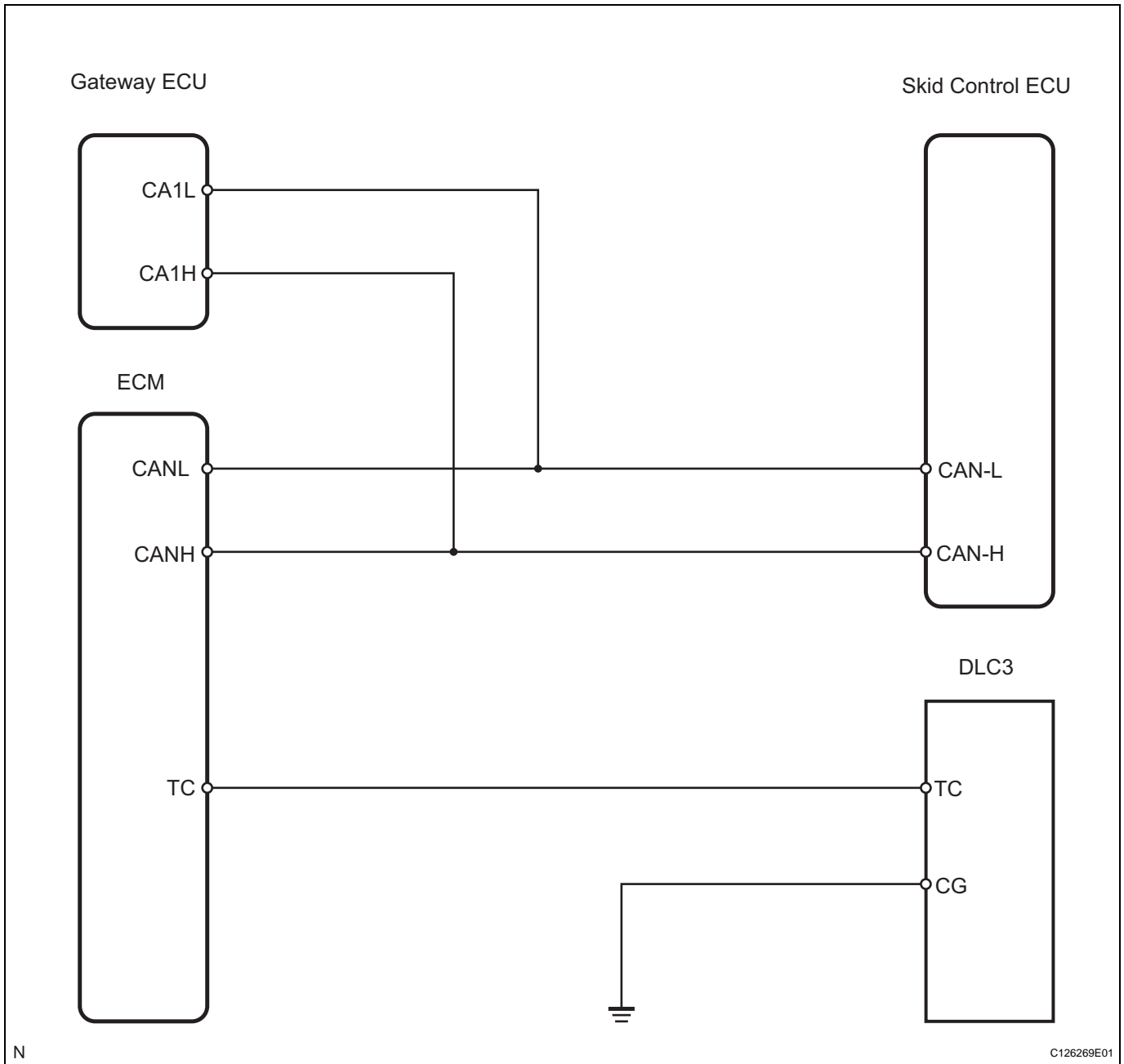

INSPECTION PROCEDURE

NOTICE:

When replacing the skid control ECU, perform initialization of linear solenoid valve and calibration (see page [BC-19](#)).

1 CHECK DLC3 (TC VOLTAGE)

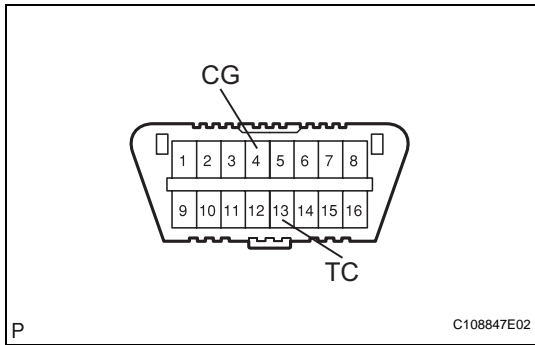

- (a) Turn the power switch ON (READY).
- (b) Measure the voltage of the DLC3 connector.

Standard voltage

Tester Connection	Specified Condition
D1-13 (TC) - Body ground	10 to 14 V

- (c) Measure the resistance of the DLC3 connector.

Standard resistance

Tester Connection	Specified Condition
D1-4 (CG) - Body ground	Below 1 Ω

NG → **Go to step 3**

OK

2 CHECK CAN COMMUNICATION SYSTEM

- (a) Check if a CAN communication system DTC is output (see page CA-6).

Result

Result	Proceed to
DTC is not output	A
DTC is output	B

B → **REPAIR CIRCUIT INDICATED BY OUTPUT CODE**

A

REPLACE SKID CONTROL ECU

3 CHECK WIRE HARNESS AND CONNECTORS (DLC3 - ECM)

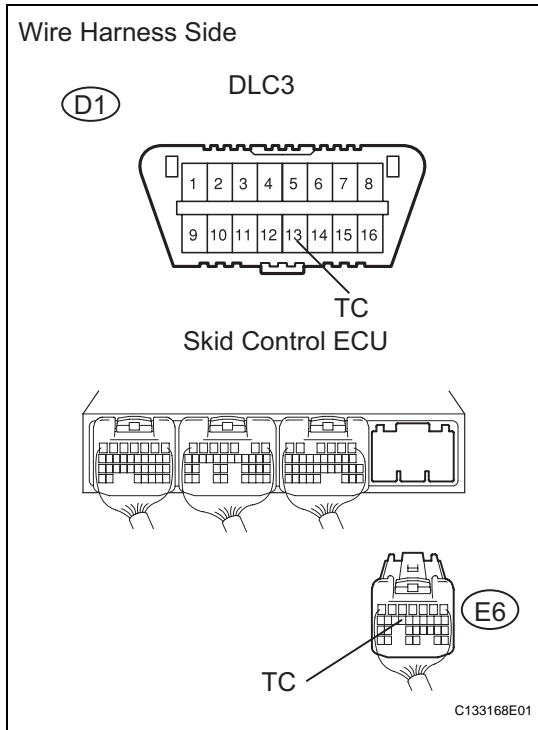

- (a) Disconnect the slid control ECU connector.
- (b) Measure the resistance of the wire harness side connectors.

Standard resistance

Tester Connection	Specified Condition
D1-13 (TC) - E6-14 (TC)	Below 1 Ω
D1-13 (TC) - Body ground	10 kΩ or higher

NG REPAIR OR REPLACE HARNESS AND CONNECTOR

OK

4 CHECK WIRE HARNESS (DLC3 - BODY GROUND)

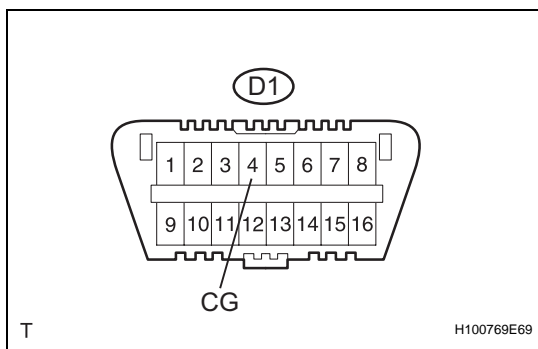

- (a) Measure the resistance of the DLC3 connector.
- Standard resistance**

Tester Connection	Specified Condition
D1-4 (CG) - Body ground	Below 1 Ω

NG REPAIR OR REPLACE HARNESS AND CONNECTOR

OK

5 CHECK CAN COMMUNICATION SYSTEM

- (a) Check if a CAN communication system DTC is output (see page CA-6).

Result

Result	Proceed to
DTC is not output	A
DTC is output	B

B

REPAIR CIRCUIT INDICATED BY OUTPUT
CODE

A

REPLACE SKID CONTROL ECU

TS and CG Terminal Circuit

DESCRIPTION

In the sensor check mode, a malfunction of the speed sensor that cannot be detected when the vehicle is stopped is detected while driving.

Transition to the sensor check mode can be performed by connecting terminals TS and CG of the DLC3 and turning the power switch from OFF to ON (READY).

WIRING DIAGRAM

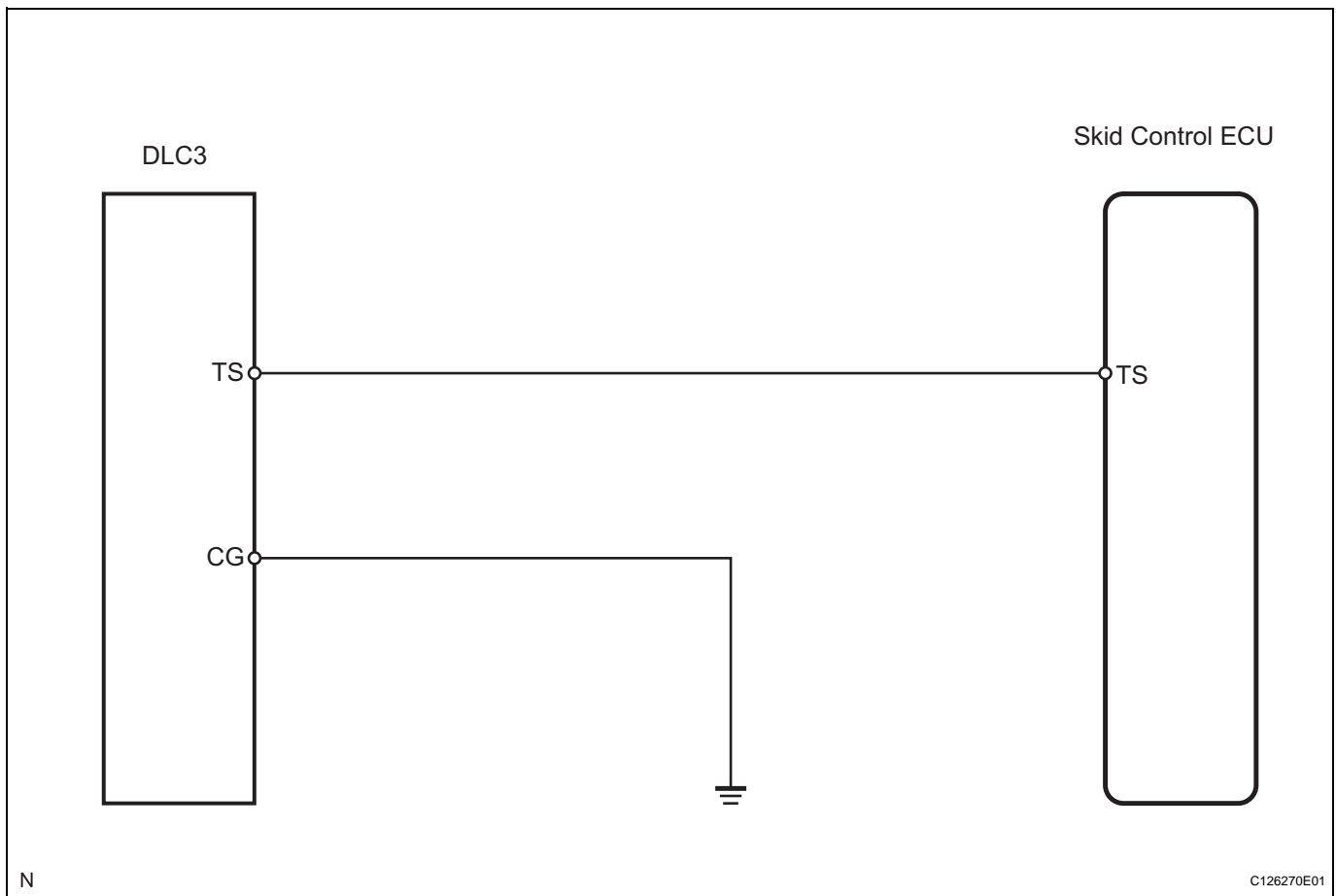

INSPECTION PROCEDURE

NOTICE:

When replacing the skid control ECU, perform initialization of linear solenoid valve and calibration (see page [BC-19](#)).

1 CHECK DLC3 (TS VOLTAGE)

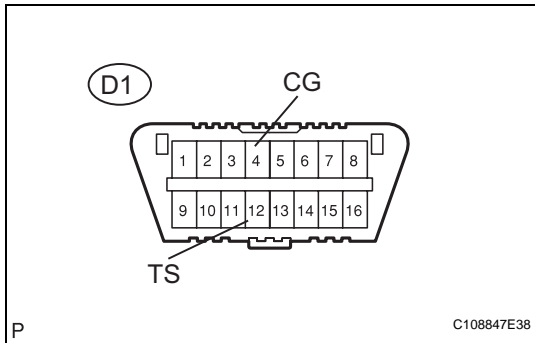

- (a) Turn the power switch ON (READY).
- (b) Measure the voltage of the DLC3.

Standard voltage

Tester Connection	Specified Condition
D1-12 (TS) - D1-4 (CG)	10 to 14 V

NG → **Go to step 3**

OK

2 CHECK WIRE HARNESS (SKID CONTROL ECU - DLC3)

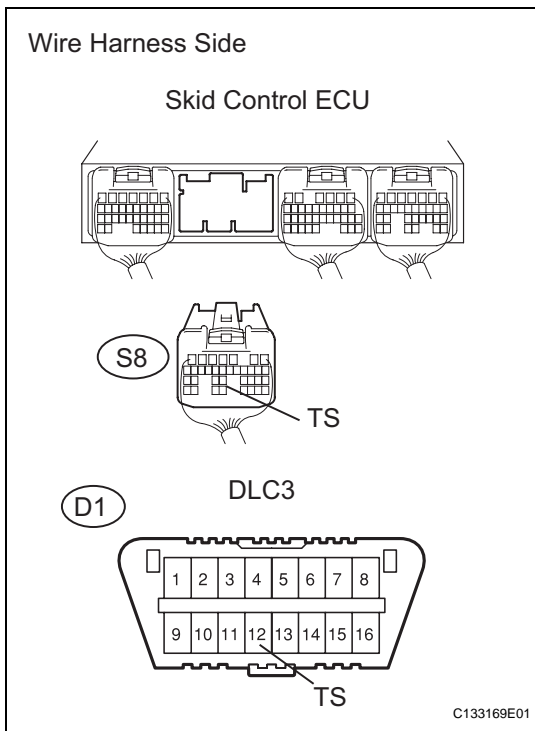

- (a) Disconnect the S8 ECU connector.
- (b) Measure the resistance of the wire harness side connectors.

Standard resistance

Tester Connection	Specified Condition
S8-32 (TS) - D1-12 (TS)	Below 1 Ω
S8-32 (TS) - Body ground	10 kΩ or higher

NG → **REPAIR OR REPLACE HARNESS AND CONNECTOR**

OK

BC

REPLACE SKID CONTROL ECU

3 CHECK WIRE HARNESS (DLC3 - BODY GROUND)

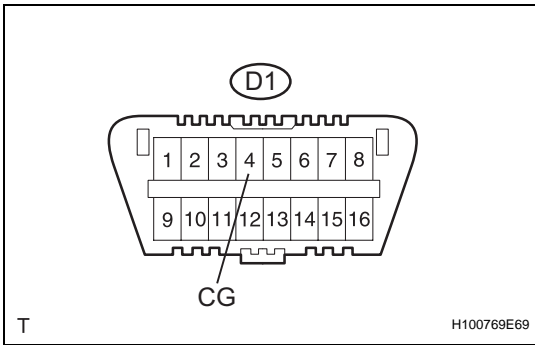

- (a) Measure the resistance of the DLC3 connector.
Standard resistance

Tester Connection	Specified Condition
D1-4 (CG) - Body ground	Below 1 Ω

NG REPAIR OR REPLACE HARNESS AND CONNECTOR

OK

4 CHECK WIRE HARNESS (SKID CONTROL ECU - DLC3)

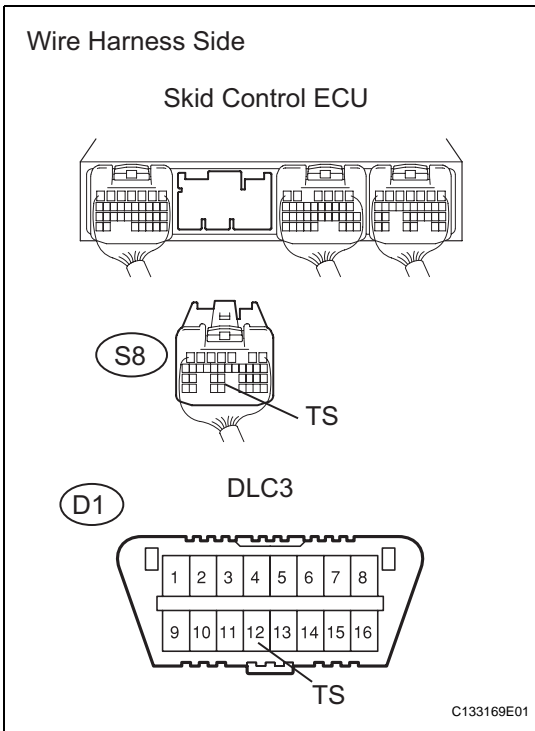

- (a) Disconnect the S8 ECU connector.
- (b) Measure the resistance of the wire harness side connector.
Standard resistance

Tester Connection	Specified Condition
S8-32 (TS) - D1-12 (TS)	Below 1 Ω
S8-32 (TS) - Body ground	10 kΩ or higher

NG REPAIR OR REPLACE HARNESS AND CONNECTOR

OK

REPLACE SKID CONTROL ECU

BRAKE ACTUATOR

COMPONENTS

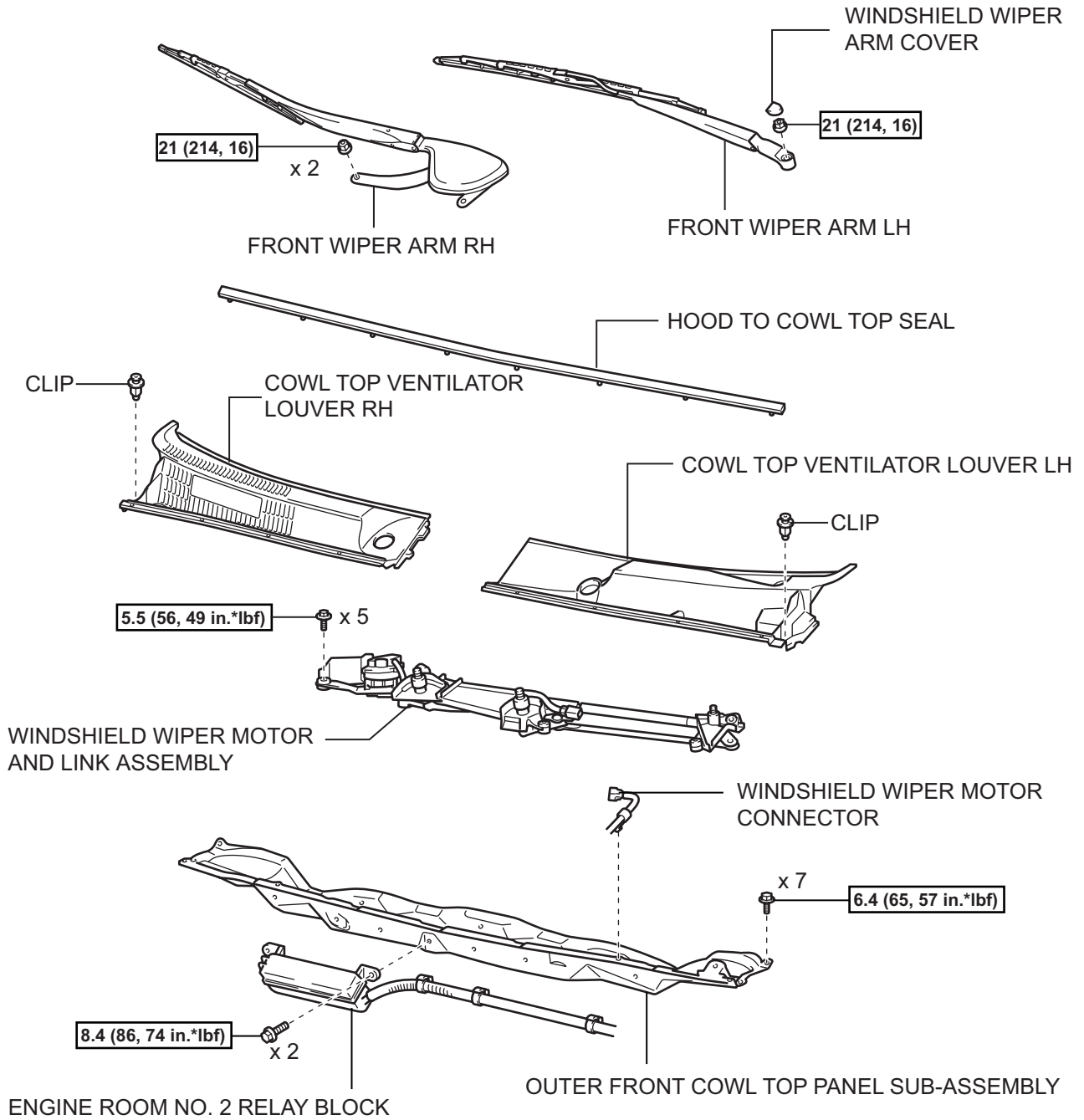

N*m (kgf*cm, ft.*lbf) : Specified torque

BC

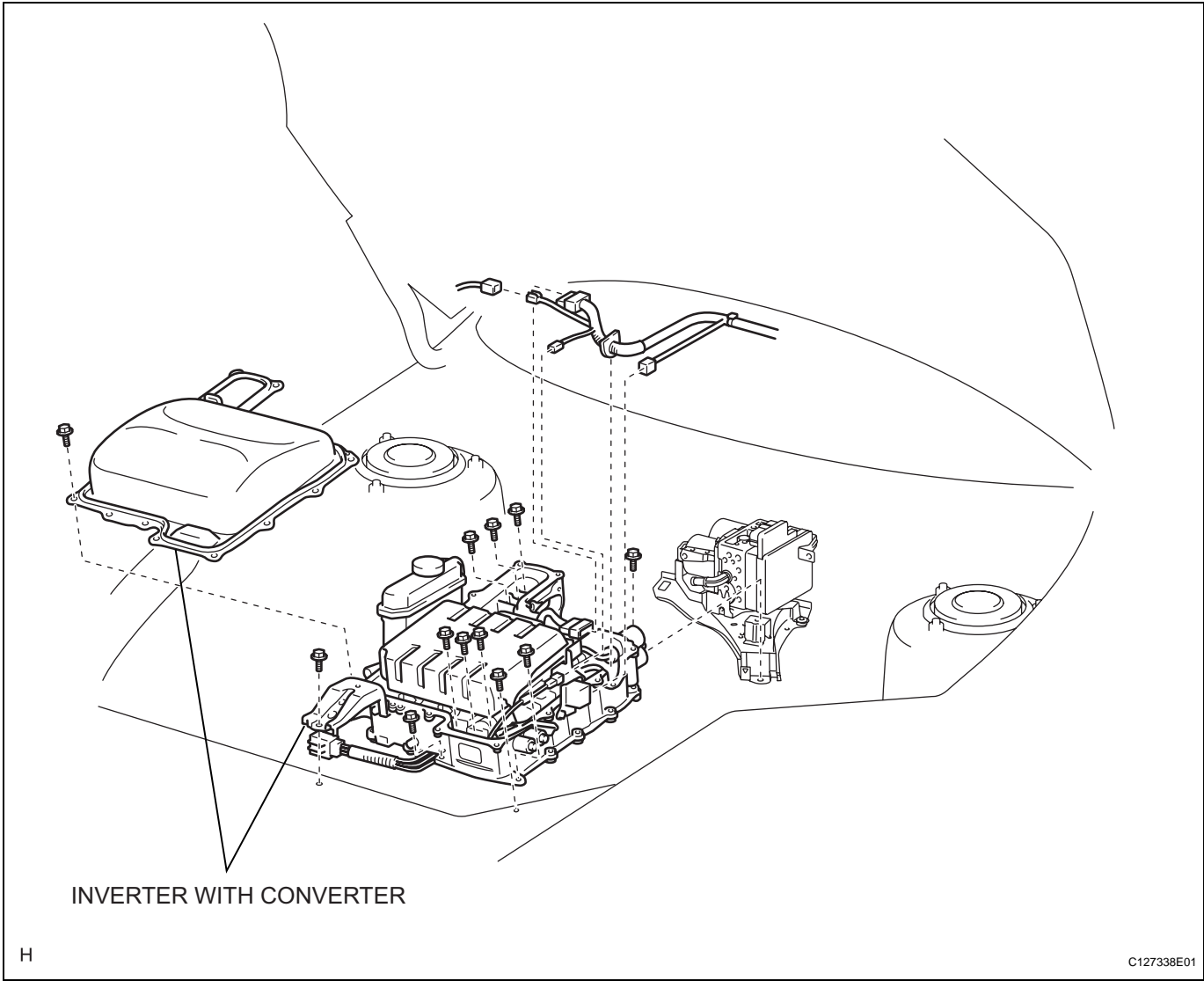

H

C127338E01

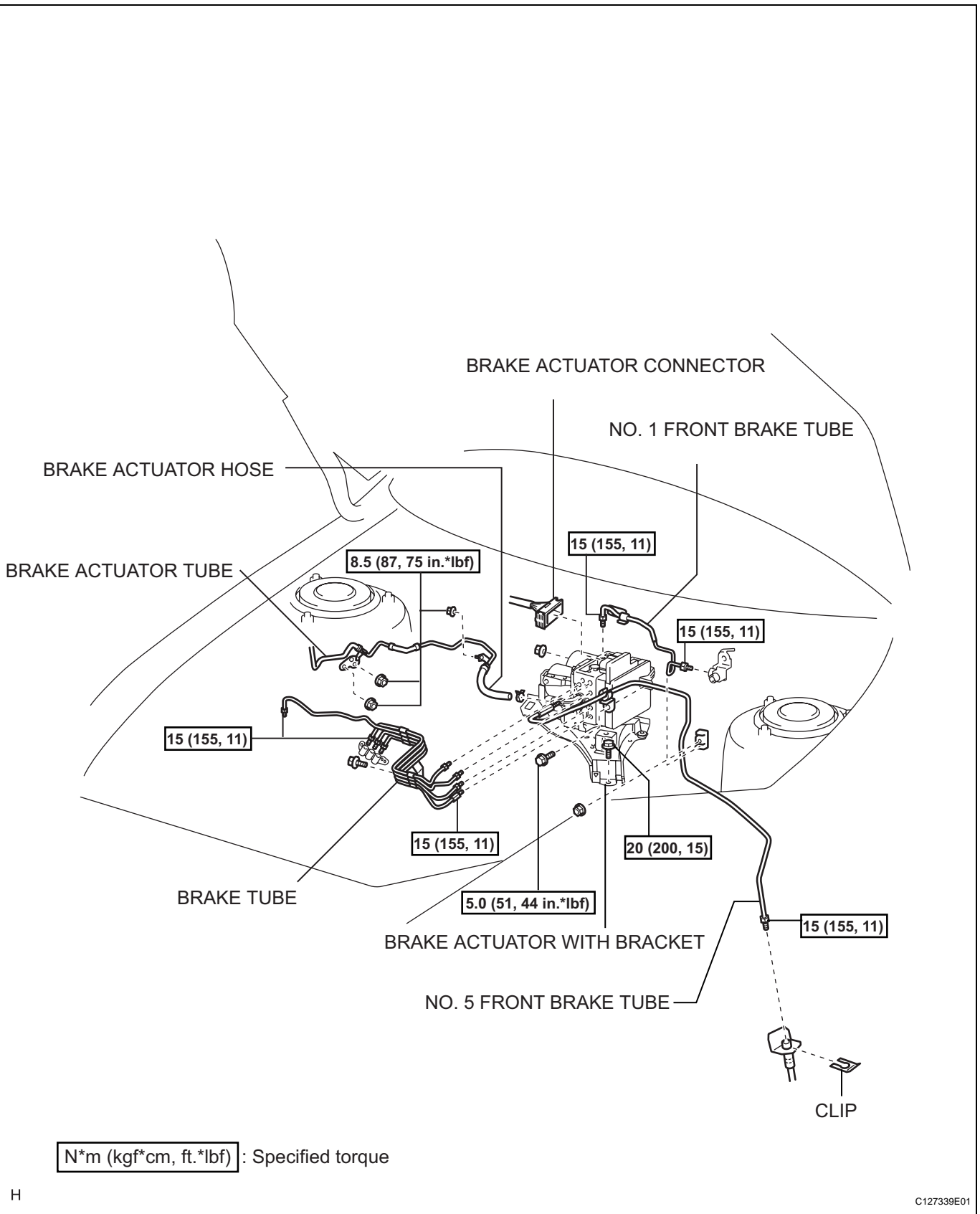

BC

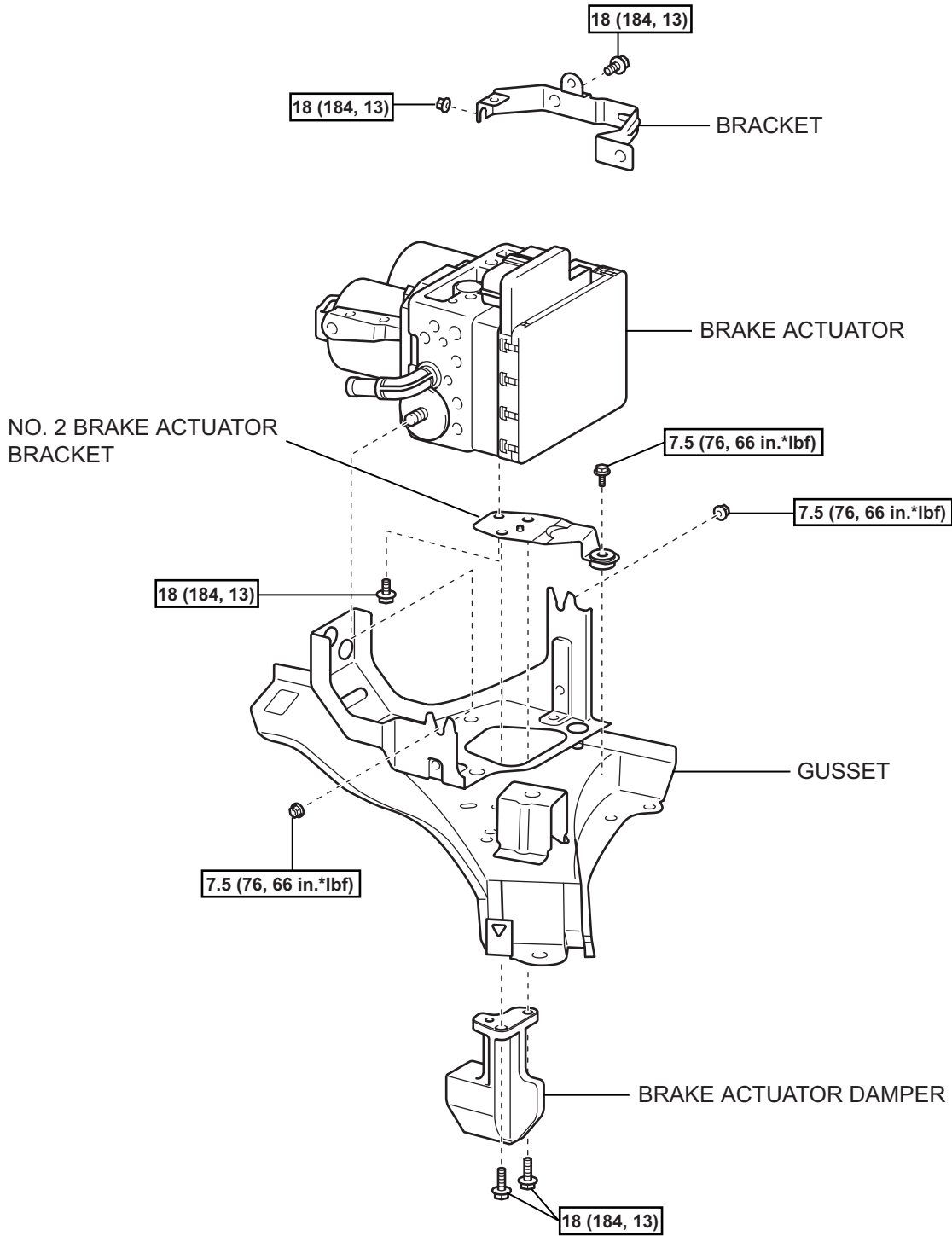

N*m (kgf*cm, ft.*lbf) : Specified torque

BC

ON-VEHICLE INSPECTION

1. INSPECT BRAKE ACTUATOR OPERATION

- (a) Pre-check preparation
 - (1) Move the shift lever to the P position. Apply the parking brake and connect the intelligent tester to the DLC3.
 - (2) Turn the power switch ON (IG).
 - (3) Turn on the intelligent tester. Select "MAS CYL PRS 1", "MAS CYL PRS 2", "FR PRESS SENS", "FL PRESS SENS", "RR PRESS SENS" and "RL PRESS SENS".
- (b) Check FR system solenoid (SLA**, SLR**, SMC1, SMC2)
 - (1) Select "SLAFR CUR". → Set the current to 1.2 A. → Check the output voltage.

NOTICE:

Do not depress the brake pedal.

HINT:

It takes approximately 35 seconds to complete the check.

If incorrect, troubleshoot the brake system (see page [BC-28](#)).

Standard output voltage

Sensor	10 to 20 sec. after check start (V)	35 sec. or more after check start (V)
MAS CYL PRS 1	0.3 to 0.7	0.3 to 0.7
MAS CYL PRS 2	0.3 to 0.7	0.3 to 0.7
FR PRESS SENS	2.5 to 4.5	0.3 to 0.7
FL PRESS SENS	0.3 to 0.7	0.3 to 0.7
RR PRESS SENS	0.3 to 0.7	0.3 to 0.7
RL PRESS SENS	0.3 to 0.7	0.3 to 0.7

- (c) Check FL system solenoid (SLA**, SLR**, SMC1, SMC2)
 - (1) Select "SLAFL CUR". → Set the current to 1.2 A. → Check the output voltage.

NOTICE:

Do not depress the brake pedal.

HINT:

It takes approximately 35 seconds to complete the check.

If incorrect, troubleshoot the brake system (see page [BC-28](#)).

Standard output voltage

Sensor	10 to 20 sec. after check start (V)	35 sec. or more after check start (V)
MAS CYL PRS 1	0.3 to 0.7	0.3 to 0.7
MAS CYL PRS 2	0.3 to 0.7	0.3 to 0.7
FR PRESS SENS	0.3 to 0.7	0.3 to 0.7
FL PRESS SENS	2.5 to 4.5	0.3 to 0.7
RR PRESS SENS	0.3 to 0.7	0.3 to 0.7
RL PRESS SENS	0.3 to 0.7	0.3 to 0.7

- (d) Check RR system solenoid (SLA**, SLR**, SMC1, SMC2)
- (1) Select "SLARR CUR". → Set the current to 1.2 A. → Check the output voltage.

NOTICE:

Do not depress the brake pedal.

HINT:

It takes approximately 35 seconds to complete the check.

If incorrect, troubleshoot the brake system (see page [BC-28](#)).

Standard output voltage

Sensor	10 to 20 sec. after check start (V)	35 sec. or more after check start (V)
MAS CYL PRS 1	0.3 to 0.7	0.3 to 0.7
MAS CYL PRS 2	0.3 to 0.7	0.3 to 0.7
FR PRESS SENS	0.3 to 0.7	0.3 to 0.7
FL PRESS SENS	0.3 to 0.7	0.3 to 0.7
RR PRESS SENS	2.5 to 4.5	0.3 to 0.7
RL PRESS SENS	0.3 to 0.7	0.3 to 0.7

- (e) Check RL system solenoid (SLA**, SLR**, SMC1, SMC2)
- (1) Select "SLARL CUR". → Set the current to 1.2 A. → Check the output voltage.

NOTICE:

Do not depress the brake pedal.

HINT:

It takes approximately 35 seconds to complete the check.

If incorrect, troubleshoot the brake system (see page [BC-28](#)).

Standard output voltage

Sensor	10 to 20 sec. after check start (V)	35 sec. or more after check start (V)
MAS CYL PRS 1	0.3 to 0.7	0.3 to 0.7
MAS CYL PRS 2	0.3 to 0.7	0.3 to 0.7
FR PRESS SENS	0.3 to 0.7	0.3 to 0.7
FL PRESS SENS	0.3 to 0.7	0.3 to 0.7
RR PRESS SENS	0.3 to 0.7	0.3 to 0.7
RL PRESS SENS	2.5 to 4.5	0.3 to 0.7

- (f) Check SMC1, SMC2
- (1) Select and enter "ECB INVALID" to prohibit the brake control (ECB) on the intelligent tester menu screen.
 - (2) Check that the ECB warning light comes on.
 - (3) Check the output voltage by depressing the brake pedal.

Standard difference in output voltage

Sensor	Specified Condition
Between "MAS CYL PRES 1" and "FR PRESS SENS"	Less than 0.4 V
Between "MAS CYL PRES 2" and "FL PRESS SENS"	Less than 0.4 V

- (4) Press the return key on the intelligent tester and cancel brake control prohibition (ECB INVALID).

2. INSPECT PRESSURE SENSOR OPERATION

- (a) Check battery voltage.

Standard battery voltage:

10 to 14 V (during engine stop)

- (b) Connect the hydro booster pressure gauge and pedal effort gauge.

- (1) Install the LSPV gauge (SST) and brake pedal effort gauge.

SST 09709-29018

- (2) Bleed the air out of the hydro booster pressure gauge.

- (3) Move the shift lever to the P position. Connect intelligent tester to the DLC3 with the parking brake applied.

- (4) Turn the power switch ON (IG).

- (5) Clear the DTC (see page BC-38).

- (c) Check wheel cylinder pressure sensor and master pressure sensor.

- (1) Turn on the intelligent tester. Select "MAS CYL PRS 1", "MAS CYL PRS 2", "FR PRESS SENS", "FL PRESS SENS", "RR PRESS SENS" and "RL PRESS SENS".

- (2) Check the brake effort, pressure gauge reading, and output pressure voltage.

If incorrect, troubleshoot the brake system (see page BC-28).

Standard output voltage

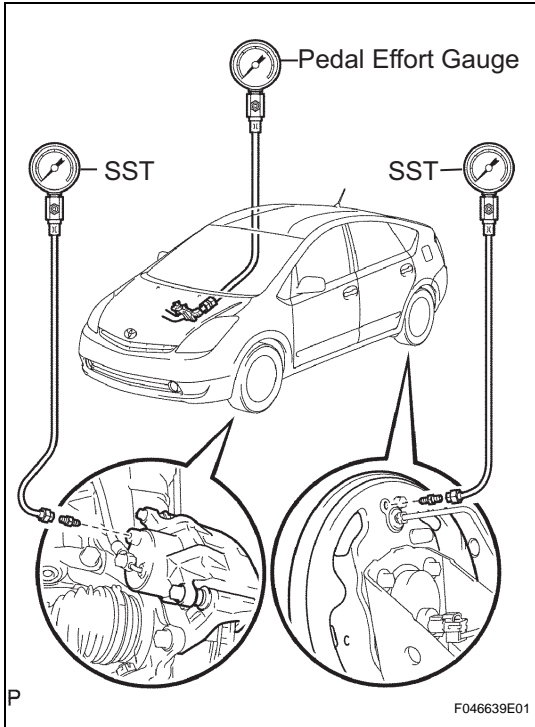

Brake effort N (kgf, lbf)	MAS CYL PRS 1 (V)	MAS CYL PRS 2 (V)
200 (20.4, 45)	0.9 to 1.2	0.9 to 1.2
500 (51, 112)	1.7 to 2.2	1.7 to 2.2

Brake effort N (kgf, lbf)	Front right wheel hydraulic pressure MPa (kgf/cm ² , psi)	FR PRESS SENS (V)
50 (5.1, 11)	3.6 (36.4, 518)	1.15 to 1.35
100 (10.2, 22)	6.9 (70.0, 996)	1.8 to 2.0
150 (15.3, 34)	9.1 (93.3, 1,327)	2.25 to 2.45
200 (20.4, 45)	11.4 (115.9, 1,648)	2.65 to 2.95

Brake effort N (kgf, lbf)	Front left wheel hydraulic pressure MPa (kgf/cm ² , psi)	FL PRESS SENS (V)
50 (5.1, 11)	3.6 (36.4, 518)	1.15 to 1.35
100 (10.2, 22)	6.9 (70.0, 996)	1.8 to 2.0
150 (15.3, 34)	9.1 (93.3, 1,327)	2.25 to 2.45
200 (20.4, 45)	11.4 (115.9, 1,648)	2.65 to 2.95

Brake effort N (kgf, lbf)	Rear right wheel hydraulic pressure MPa (kgf/cm ² , psi)	RR PRESS SENS (V)
50 (5.1, 11)	3.9 (39.4, 560)	1.2 to 1.4
100 (10.2, 22)	4 (40.8, 580)	1.25 to 1.5
150 (15.3, 34)	4 (40.8, 580)	1.25 to 1.5
200 (20.4, 45)	4 (40.8, 580)	1.25 to 1.5

Brake effort N (kgf, lbf)	Rear left wheel hydraulic pressure MPa (kgf/cm ² , psi)	RL PRESS SENS (V)
50 (5.1, 11)	3.9 (39.4, 560)	1.2 to 1.4
100 (10.2, 22)	4 (40.8, 580)	1.25 to 1.5
150 (15.3, 34)	4 (40.8, 580)	1.25 to 1.5
200 (20.4, 45)	4 (40.8, 580)	1.25 to 1.5

- (d) Check accumulator (ACC) pressure sensor.
- (1) Move the shift lever to the P position. Apply the parking brake and connect the intelligent tester.
 - (2) Turn the power switch ON (IG).
 - (3) Turn on the intelligent tester. Select the accumulator (ACC) pressure sensor 1 ("ACC PRESS SENS").
 - (4) Temporarily operate the pump motor by depressing the brake pedal 4 to 5 times.
 - (5) After confirming that the pump motor stops, check the pressure output voltage. If incorrect, troubleshoot the brake system (see page [BC-28](#)).

Standard output voltage:

2.6 to 3.8 V

REPLACEMENT

NOTICE:

Be sure to replace the actuator and the resistor together. If they are not replaced together, motor noise may be increased.

1. REPLACE BRAKE ACTUATOR ASSEMBLY

- (a) Remove the windshield wiper motor and link (see page [WW-13](#)).

HINT:

Refer to the procedures from the removal of the front wiper arm LH/RH up until the removal of the windshield wiper motor and link assembly.

- (b) Perform the accumulator pressure "ZERO DOWN" operation.

NOTICE:

Carry out the accumulator "ZERO DOWN" operation and lower the internal pressure before removing the brake actuator.

- (1) Move the shift lever to the P position. Apply the parking brake and connect the intelligent tester to the DLC3.
- (2) Turn the power switch ON (IG).
- (3) Turn on the intelligent tester. Select "ZERO DOWN".

NOTICE:

Keep the fluid inside the reservoir above the "LOW" level by replenishing.

HINT:

- Accumulator pressure is released and accumulated repeatedly, which circulates the fluid inside the accumulator when performing this procedure.
- The pump motor rotates and the accumulator is pressurized every time turning the power switch from OFF to ON (IG).

- (4) Turn the power switch OFF.

- (c) Set the brake control (ECB) off.

NOTICE:

- **Prohibit the brake control (ECB) before air bleeding.**
- **Be sure to remove the No. 1 and No. 2 motor relays first, then the brake actuator.**

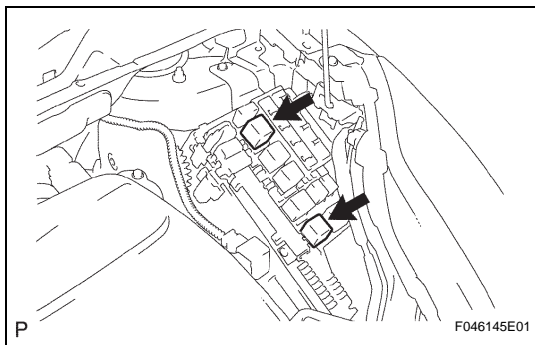

- (1) With the power switch OFF to prohibit brake control, remove the No. 1 and No. 2 motor relays.

NOTICE:

If the pump motor operates while there is air remaining inside the brake actuator hose, the air will enter the actuator, resulting in difficulty in air bleeding.

- (d) Remove the outer front cowl top panel (see page [BR-28](#)).
- (e) Remove the inverter with converter (see page [HV-530](#)).

HINT:

Refer to the procedures from the removal of the engine under cover LH up until the removal of the inverter with converter.

- (f) Drain brake fluid.

NOTICE:

Wash brake fluid off immediately if it adheres to any painted surface.

- (g) Separate the water pump with motor and bracket.
- (1) Disconnect the connector.
 - (2) Remove the 2 bolts and disconnect the water pump from the gusset.

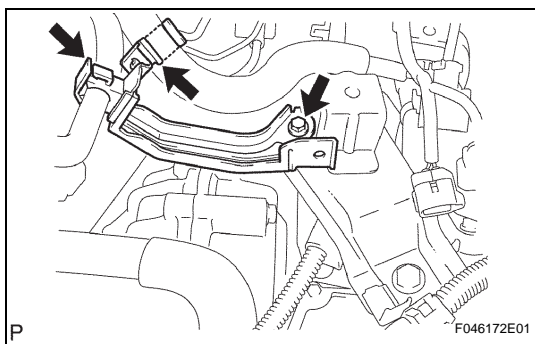
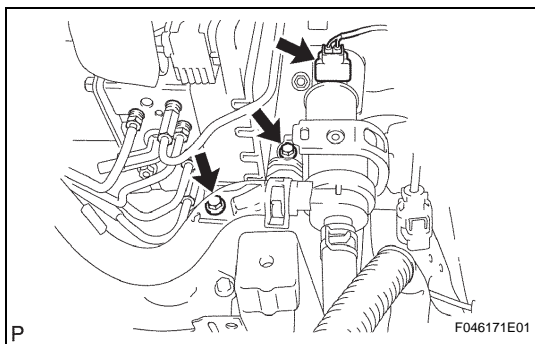

- (3) Remove the 2 clamps, bolt and heater hose bracket from the gusset.

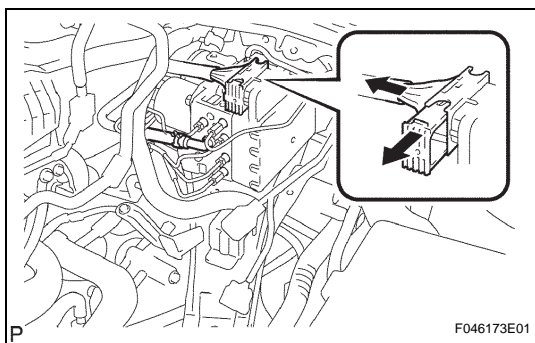

- (h) Remove the brake actuator with bracket.
- (1) Release the lock and disconnect the brake actuator connector.
 - (2) Remove the clip and disconnect the No. 2 brake actuator hose from the brake actuator.

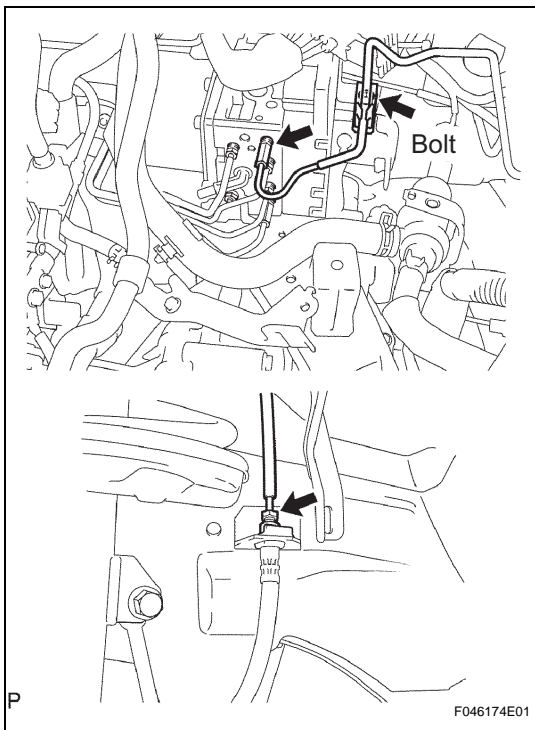

- (3) Using SST, disconnect the No. 5 front brake tube from the brake actuator and front brake flexible hose.
SST 09023-00101
- (4) Remove the bolt and No. 5 front brake tube from the bracket of the brake actuator.

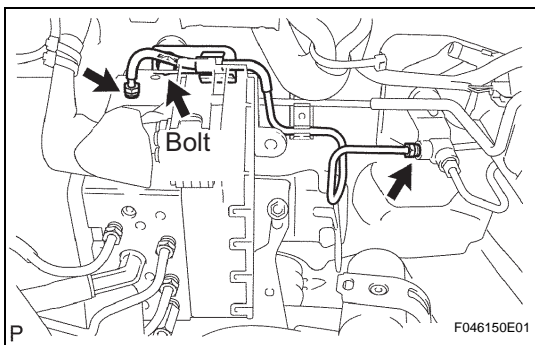

- (5) Using SST, disconnect the No. 1 front brake tube.
SST 09023-00101
- (6) Remove the bolt and No. 1 front brake tube from the bracket of the brake actuator.

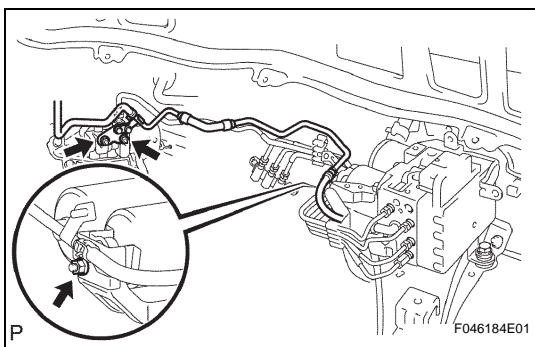

- (7) Remove the 3 nuts and brake actuator tubes from the brake stroke simulator cylinder and brake actuator.

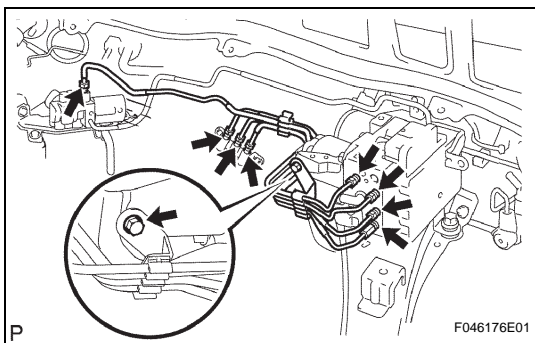

- (8) Remove the bolt from the brake actuator.
- (9) Using SST, remove the 4 brake tubes from the brake stroke simulator cylinder and brake actuator.
SST 09023-00101

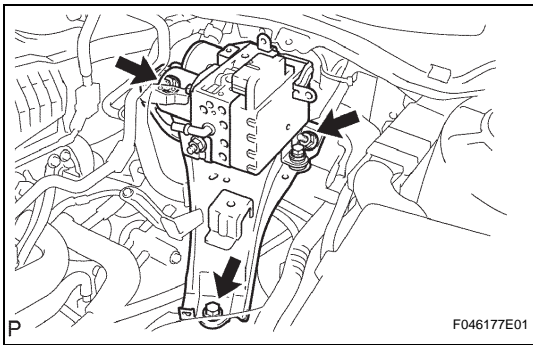

(10) Remove the bolt, 2 nuts and brake actuator with gusset.

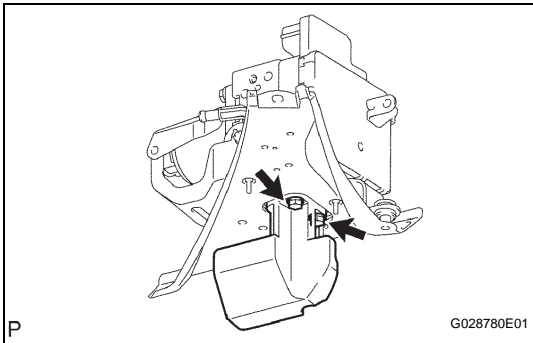

- (i) Remove the brake actuator.
 - (1) Remove the 2 bolts and brake actuator damper.

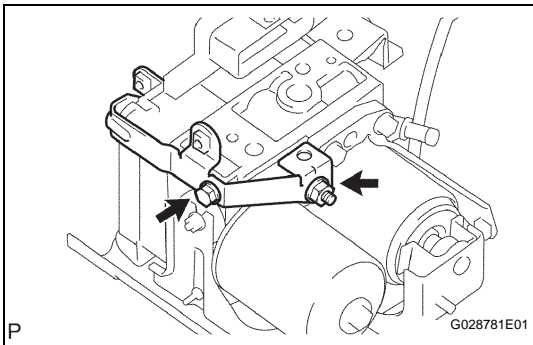

(2) Remove the bolt, nut and bracket from the brake actuator.

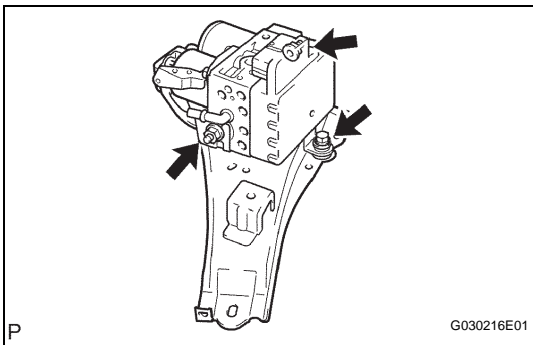

(3) Remove the 2 nuts, bolt and brake actuator from the gusset.

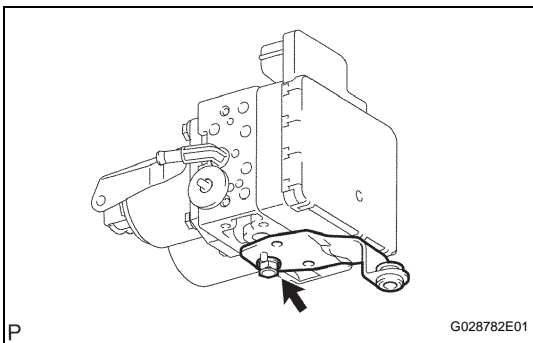

(4) Remove the bolt and No. 2 brake actuator bracket from the brake actuator.

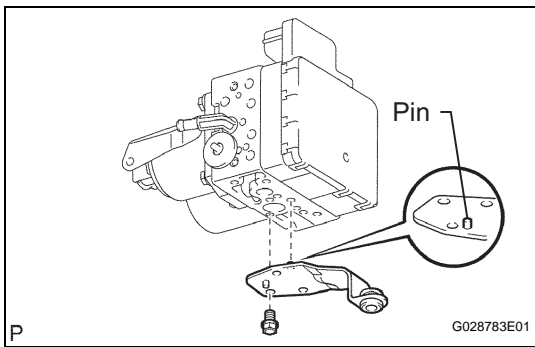

- (j) Install the brake actuator.
 - (1) Aligning the positioning pin, install the No. 2 brake actuator bracket to the brake actuator with the bolt.
Torque: 18 N*m (184 kgf*cm, 13 ft.*lbf)

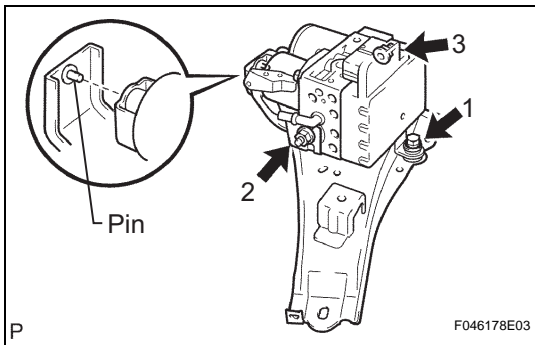

- (2) Aligning the positioning pin, install the brake actuator to the gusset with the 2 nuts and bolt.
Torque: 7.5 N*m (76 kgf*cm, 66 in.*lbf)
NOTICE:
Tighten the nuts and bolt in the order shown in the illustration.

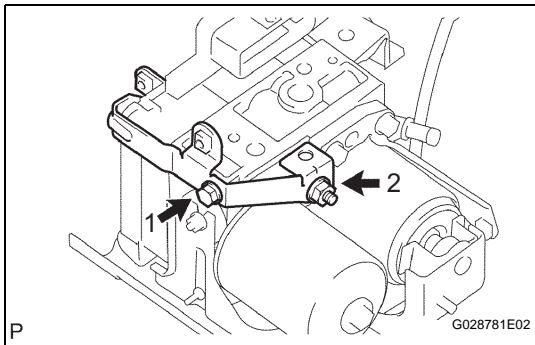

- (3) Install the bracket to the brake actuator with the bolt and nut.
Torque: 18 N*m (184 kgf*cm, 13 ft.*lbf)
NOTICE:
Tighten the nut and bolt in the order shown in the illustration.

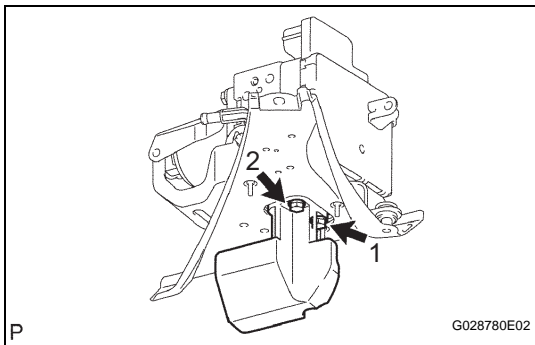

- (4) Install the brake actuator damper to the brake actuator with the 2 bolts.
Torque: 18 N*m (184 kgf*cm, 13 ft.*lbf)
NOTICE:
Tighten the bolts in the order shown in the illustration.

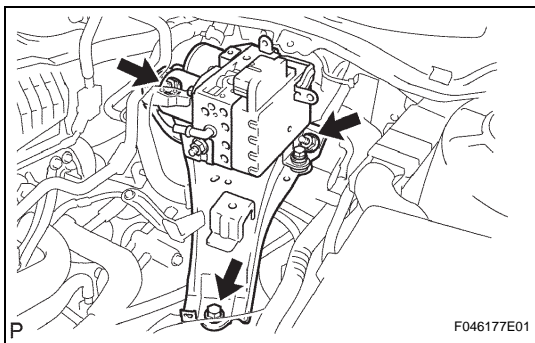

- (k) Install the brake actuator with bracket.
 - (1) Install the brake actuator with gusset with the bolt and 2 nuts.
Torque: 20 N*m (200 kgf*cm, 15 ft.*lbf)

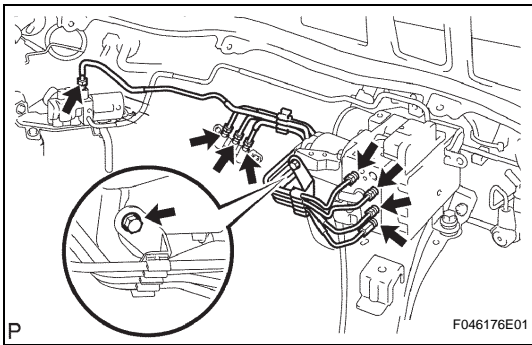

- (2) Using SST, install the 4 brake tubes to the brake stroke simulator cylinder and brake actuator.

SST 09023-00101

Torque: 15 N*m (155 kgf*cm, 11 ft.*lbf)

- (3) Set the brake tube with the clamp bracket bolt.
Torque: 5.0 N*m (51 kgf*cm, 44 in.*lbf)

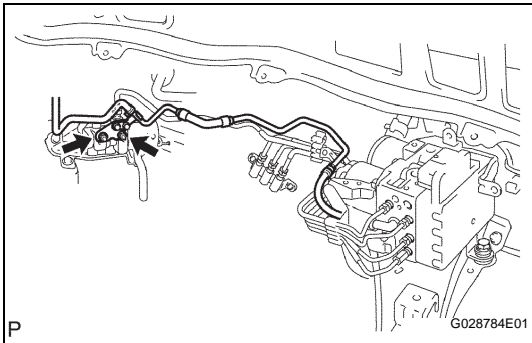

- (4) Install the brake actuator tube with the 2 nuts.
Torque: 8.5 N*m (87 kgf*cm, 75 in.*lbf)

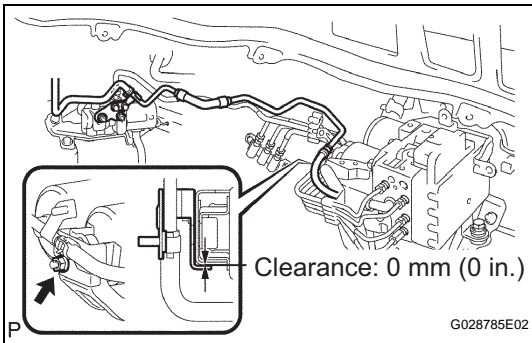

- (5) Set the brake actuator tube with the nut.
Torque: 8.5 N*m (87 kgf*cm, 75 in.*lbf)

NOTICE:

Press the brake actuator tube so that there is no clearance between the bracket and the actuator tube as shown in the illustration, and tighten the nut.

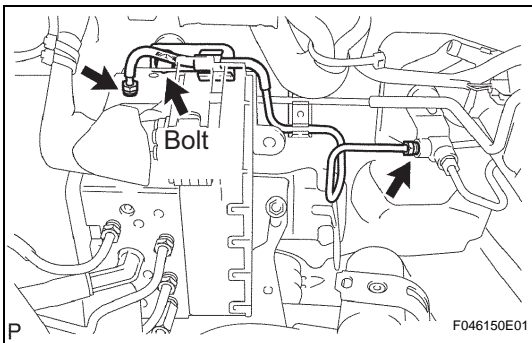

- (6) Using SST, install the No. 1 front brake tube to the brake actuator and 2-way.

SST 09023-00101

Torque: 15 N*m (155 kgf*cm, 11 ft.*lbf)

- (7) Install the No. 1 front brake tube to the bracket of the brake actuator with the bolt.

Torque: 5.0 N*m (51 kgf*cm, 44 in.*lbf)

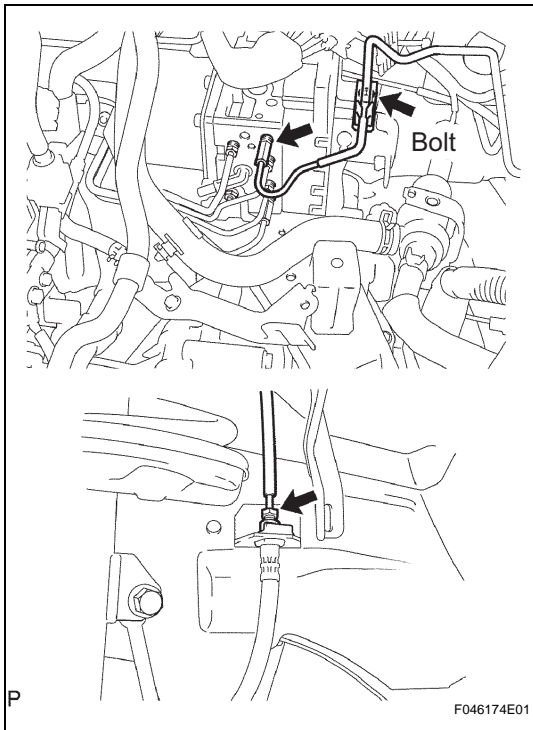

- (8) Using SST, connect the No. 5 front brake tube.
SST 09023-00101
Torque: 15 N*m (155 kgf*cm, 11 ft.*lbf)
- (9) Install the bracket of the No. 5 front brake tube with the bolt.
Torque: 5.0 N*m (51 kgf*cm, 44 in.*lbf)

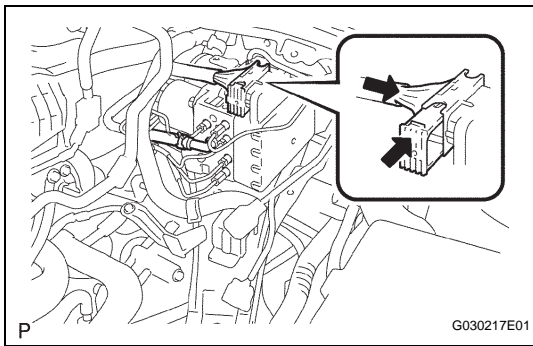

- (10) Connect the brake actuator connector and fix it with the lock.
- (11) Install the No. 2 brake actuator hose to the brake actuator with the clip.

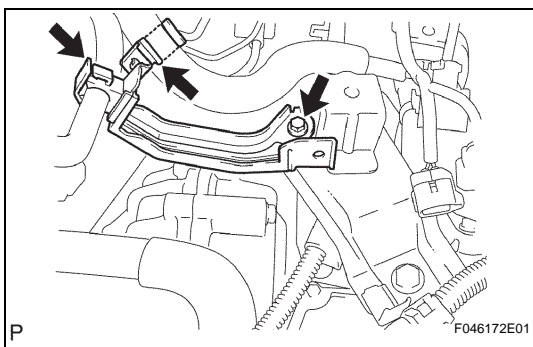

- (l) Connect the water pump with motor and bracket.
 - (1) Install the heater hose bracket to the gusset with the 2 clamps and bolt.

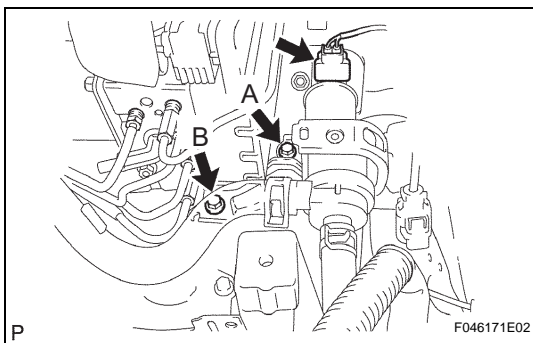

- (2) Install the heater water pump with the 2 bolts.
NOTICE:
Tighten bolt A and then bolt B.
- (3) Connect the heater water pump connector.
- (m) Install the inverter with converter (see page [HV-535](#)).
HINT:
Refer to the procedures from the installation of the inverter with converter up until the installation of the engine under cover LH.

- (n) Install the outer front cowl top panel (see page [BR-32](#)).
- (o) Install the windshield wiper motor and link (see page [WW-15](#)).

HINT:

Refer to the procedures from the installation of the windshield wiper motor and link assembly up until the installation of the front wiper arm LH/RH.

2. REPLACE BRAKE ACTUATOR RESISTOR

- (a) Remove the instrument panel (see page [IP-5](#)).

HINT:

Refer to the procedures from the removal of the No. 1 instrument panel register assembly up until the removal of the instrument panel sub-assembly.

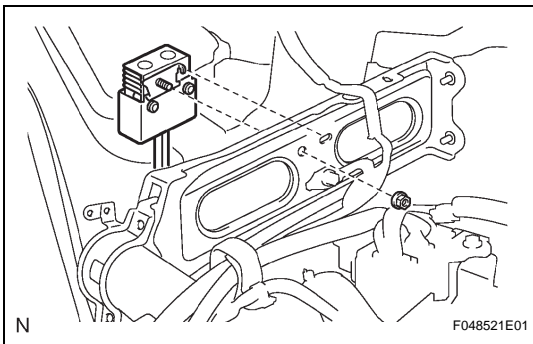

- (b) Remove the brake actuator resistor.
 - (1) Remove the nut.
 - (2) Disconnect the connector and remove the resistor.

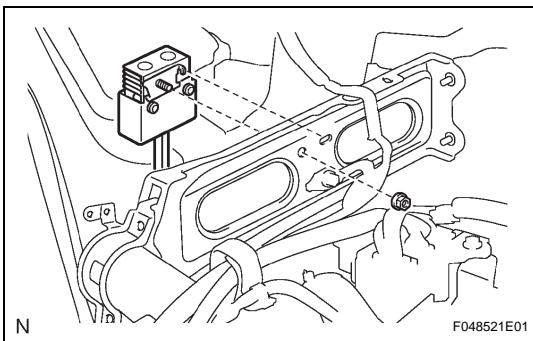

- (c) Install the brake actuator resistor.
 - (1) Connect the connector and install the resistor.
 - (2) Install the nut.

Torque: 5.0 N*m (51 kgf*cm, 44 in.*lbf)

- (d) Install the instrument panel (see page [IP-11](#)).

HINT:

Refer to the procedures from the installation of the instrument panel sub-assembly up until the installation of the No. 1 instrument panel register assembly.

3. FILL RESERVOIR WITH BRAKE FLUID (See page [BR-5](#))**4. BLEED AIR FROM BRAKE ACTUATOR (See page [BR-8](#))****5. CHECK FOR BRAKE FLUID LEAKAGE****6. CHECK FLUID LEVEL IN RESERVOIR****7. CHECK AND CLEAR DTC**

- (a) Check and clear the DTC (see page [BC-38](#)).

8. PERFORM INITIALIZATION

- (a) Perform initialization (see page [IN-32](#)).

NOTICE:

Certain systems need to be initialized after disconnecting and reconnecting the cable from the negative (-) battery terminal.

9. PERFORM SYSTEM INITIALIZATION

- (a) Perform the brake system initialization (see page [BC-19](#)).

10. PERFORM ACTIVE TEST

- (a) Perform the Active Test (see page [BC-43](#)).

DISPOSAL**1. DISPOSE OF BRAKE ACTUATOR ASSEMBLY**

- (a) Using a drill, slowly make a hole at the radius indicated at the middle of A in the illustration and bleed the charged gas.

CAUTION:

Be sure to wear protective glasses as fragments may fly out due to pressure.

HINT:

- The hole may be drilled up to approximately 5 to 10 mm (0.20 to 0.39 in.) away from the point indicated by A.
- The gas is nitrogen, which is colorless, odorless, and harmless.

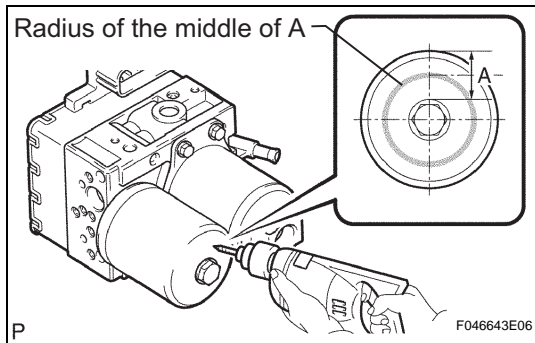

FRONT SPEED SENSOR

COMPONENTS

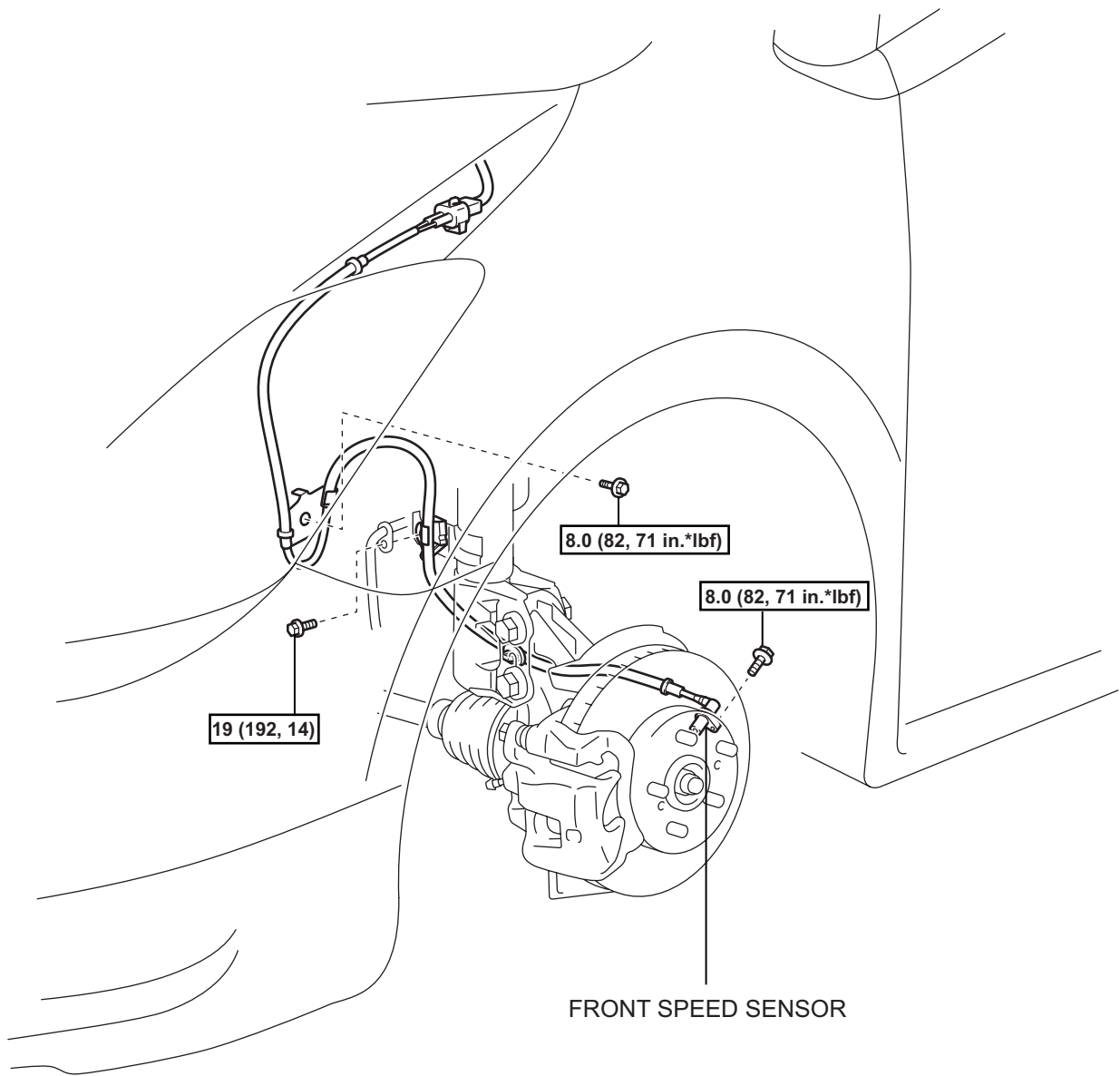

N*m (kgf*cm, ft.*lbf) : Specified torque

BC

REMOVAL

1. REMOVE FRONT WHEEL
2. REMOVE FRONT FENDER LINER
3. REMOVE FRONT SPEED SENSOR
 - (a) Disconnect the sensor connector.

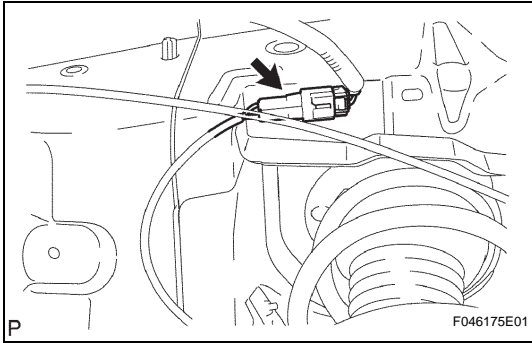

- (b) Remove the 2 bolts (A and B) and 2 sensor clamps from the body and front shock absorber.

HINT:

The bolt B is tightened together with the brake flexible hose clamp.

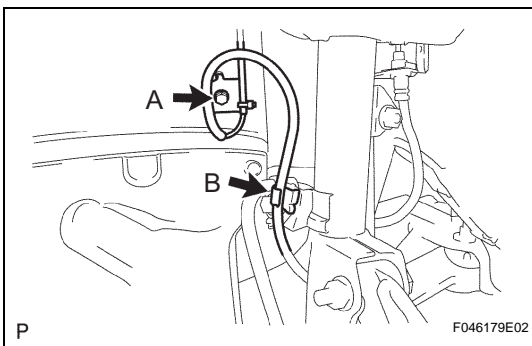

- (c) Remove the clip from the front shock absorber.
- (d) Remove the bolt and sensor.

NOTICE:

Do not allow foreign matter to attach to the tip or connecting portion of the speed sensor.

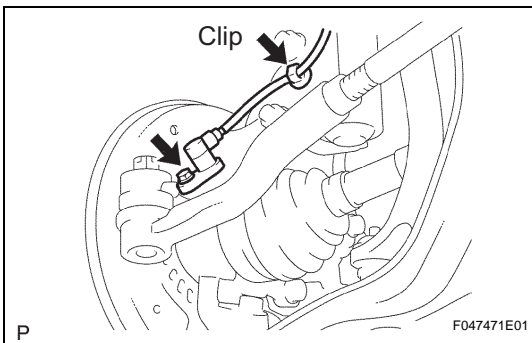

INSTALLATION

1. INSTALL FRONT SPEED SENSOR

NOTICE:

- Do not twist the sensor wire harness during installation.
- Check that there is no foreign matter attached to the tip and connecting portion of the speed sensor.

- (a) Clean the connecting portion of the sensor.
- (b) Install the sensor with the bolt.
Torque: 8.0 N*m (82 kgf*cm, 71 in.*lbf)
- (c) Install the clip to the front shock absorber.

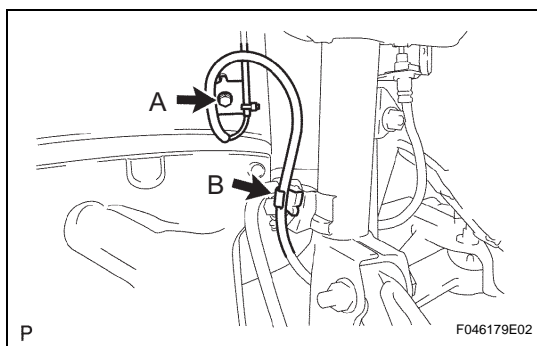
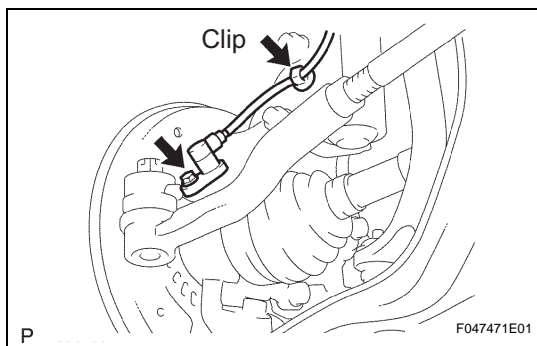

- (d) Install the sensor clamps to the body and front shock absorber with the bolts A and B.
Torque: 8.0 N*m (82 kgf*cm, 71 in.*lbf) for bolt A
19 N*m (192 kgf*cm, 14 ft.*lbf) for bolt B

NOTICE:

Tighten the bolt B together with the brake flexible hose clamp and sensor clamp. The brake flexible hose clamp should be placed above.

- (e) Connect the sensor connector.

2. INSTALL FRONT FENDER LINER

3. INSTALL FRONT WHEEL

Torque: 103 N*m (1,050 kgf*cm, 76 ft.*lbf)

4. CHECK ABS SPEED SENSOR SIGNAL

- (a) Check the speed sensor signal (see page [BC-23](#)).

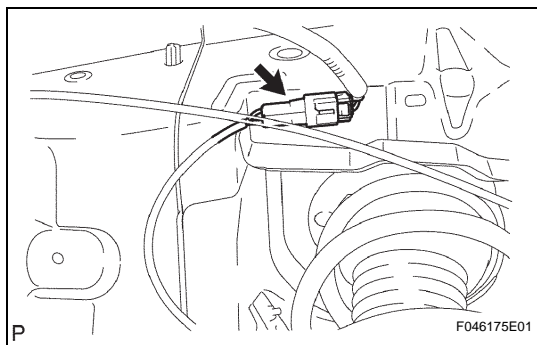

SKID CONTROL SENSOR

COMPONENTS

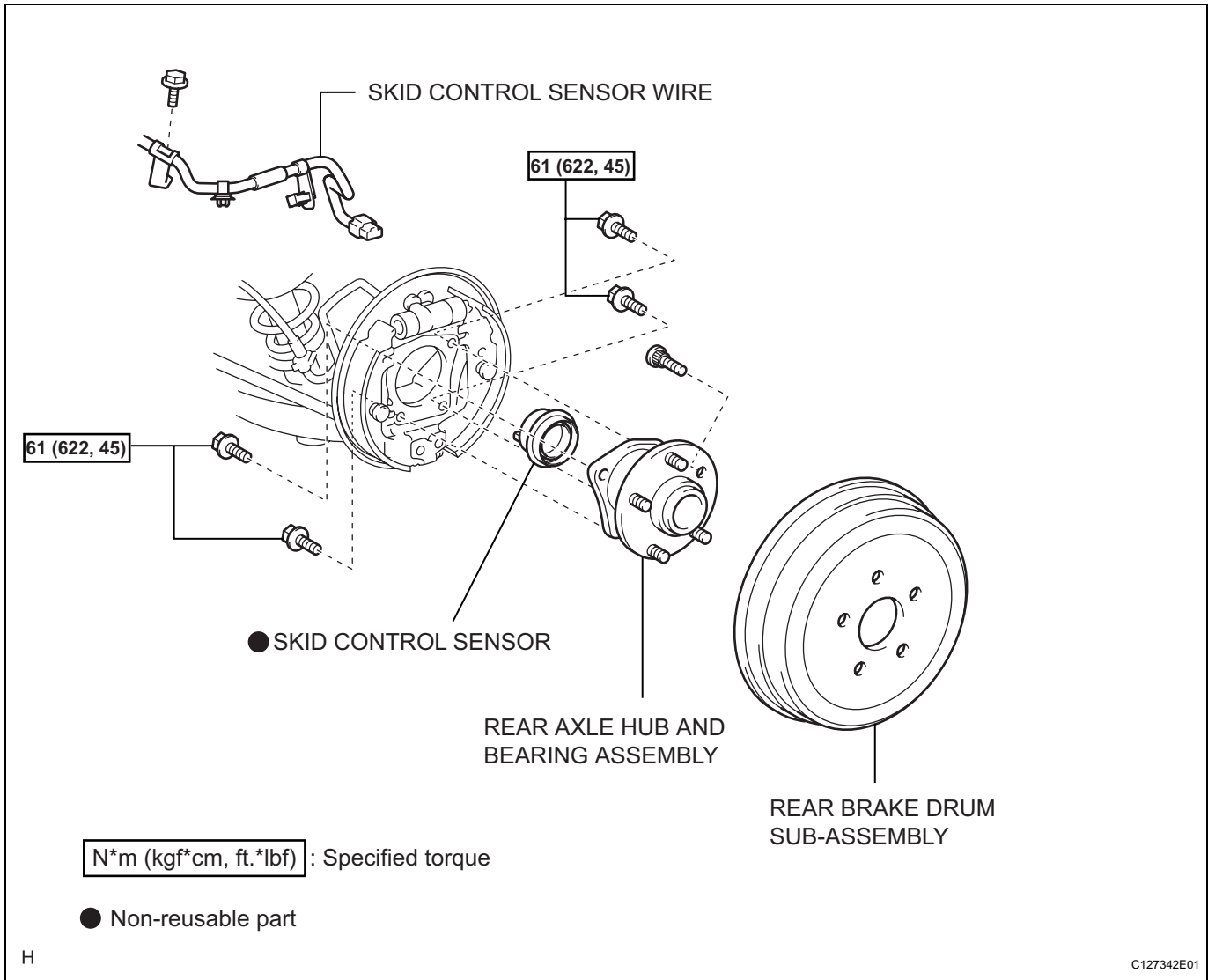

H

C127342E01

REMOVAL

1. REMOVE REAR WHEEL
2. REMOVE REAR BRAKE DRUM SUB-ASSEMBLY (See page BR-47)
3. SEPARATE SKID CONTROL SENSOR WIRE
4. REMOVE REAR AXLE HUB AND BEARING ASSEMBLY (See page AH-10)
5. REMOVE SKID CONTROL SENSOR

- (a) Install the 4 hub nuts to the 4 rear axle hub bolts. Placing an aluminum plate below the rear axle hub and bearing, place them into the vise.

NOTICE:

Replace the rear axle hub and bearing if it is dropped or receives a strong shock.

- (b) Using a pin punch (3 mm) or hammer, remove the 2 pins from SST (09520-00031) and separate the attachment (09521-00010).

- (c) Using SST and 2 bolts (90101-12007), remove the sensor from the rear axle hub and bearing.

SST 09520-00031 (09520-00040), 09521-00020, 09950-00020

NOTICE:

- **Pull the sensor off straight, being careful not to make contact with the sensor rotor.**
- **If the sensor rotor is damaged or deformed, replace the rear axle hub and bearing.**
- **Do not scratch the area where the sensor contacts the rear axle hub and bearing.**
- **Do not allow foreign matter to attach to the sensor rotor.**

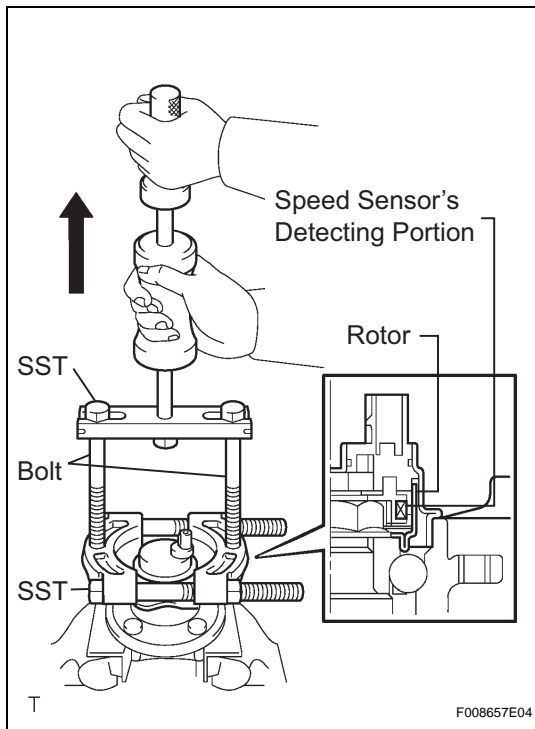

INSTALLATION

1. INSTALL SKID CONTROL SENSOR

- (a) Wipe off sealant attached to the sensor's fitting surface with white gasoline.

NOTICE:

Prevent foreign matter from attaching to the sensor rotor.

- (b) Install a new sensor to the rear axle hub and bearing. The sensor connector should be placed in the lowest position.

HINT:

The narrow side of the rear axle hub and bearing should be placed below.

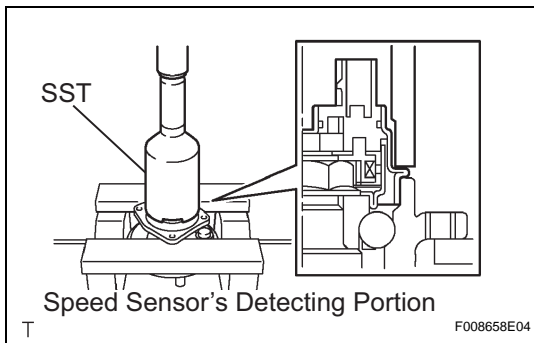
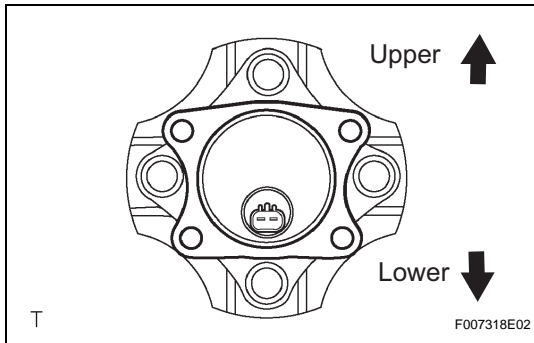

- (c) Using SST and a press, press the speed sensor so that it becomes flush with the rear axle hub and bearing.

SST 09214-76011

NOTICE:

- Do not use a hammer on the sensor.
- Check that there is no foreign matter such as iron chips on the sensor's detecting portion.
- Slowly press the sensor in straight.

2. INSTALL REAR AXLE HUB AND BEARING ASSEMBLY (See page [AH-11](#))

3. INSTALL SKID CONTROL SENSOR WIRE

4. INSTALL REAR BRAKE DRUM SUB-ASSEMBLY (See page [BR-53](#))

5. INSTALL REAR WHEEL

Torque: 103 N*m (1,050 kgf*cm, 76 ft.*lbf)

6. INSPECT REAR WHEEL ALIGNMENT

- (a) Inspect the rear wheel alignment (see page [SP-10](#)).

7. CHECK ABS SPEED SENSOR SIGNAL

- (a) Check the speed sensor signal (see page [BC-23](#)).

YAW RATE AND DECELERATION SENSOR

COMPONENTS

CONSOLE BOX POCKET

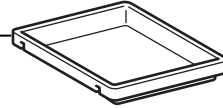

CONSOLE BOX CARPET

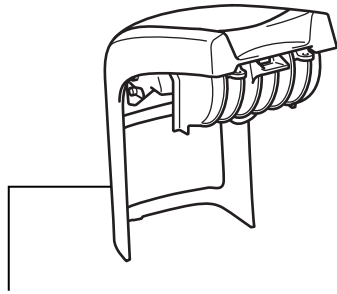
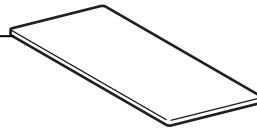

UPPER CONSOLE PANEL SUB-ASSEMBLY

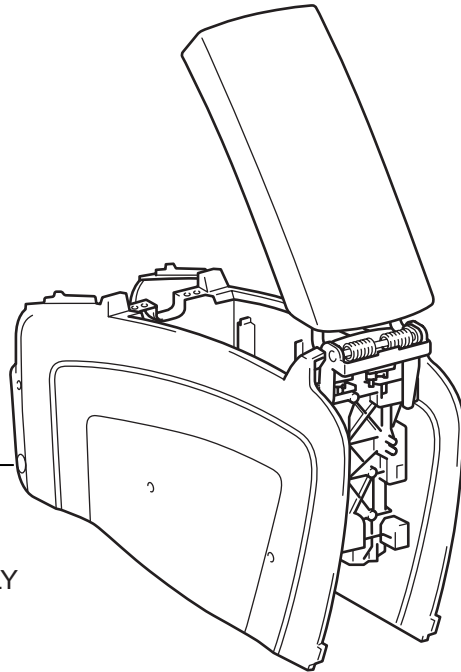

REAR CONSOLE BOX SUB-ASSEMBLY

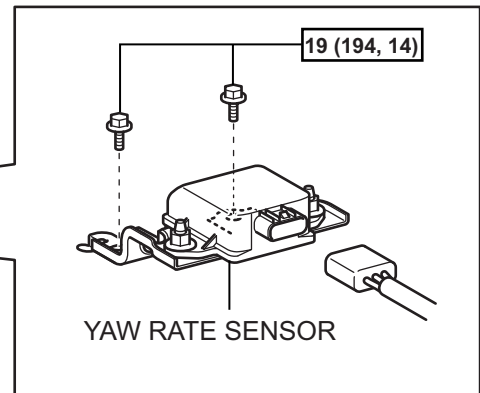
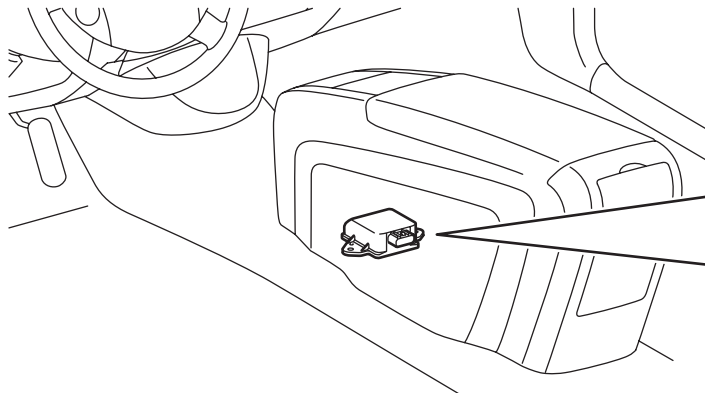

YAW RATE SENSOR

N*m (kgf*cm, ft.*lbf) : Specified torque

BC

REMOVAL

1. REMOVE UPPER CONSOLE PANEL SUB-ASSEMBLY
(See page [IP-24](#))
2. REMOVE CONSOLE BOX POCKET
3. REMOVE CONSOLE BOX CARPET
4. REMOVE REAR CONSOLE BOX SUB-ASSEMBLY
(See page [IP-24](#))
5. REMOVE YAW RATE SENSOR
 - (a) Disconnect the connector and remove the 2 bolts and sensor.

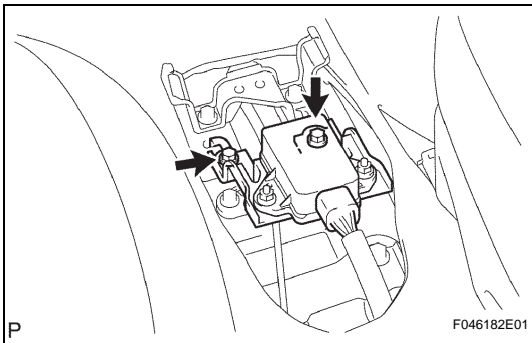
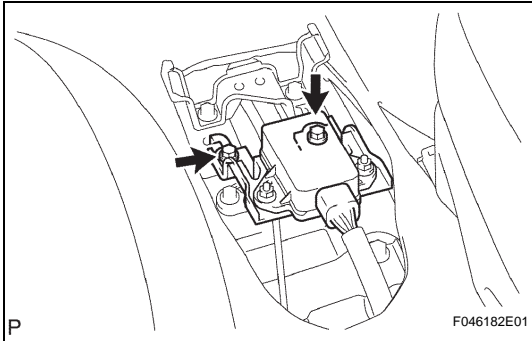

INSTALLATION

1. INSTALL YAW RATE SENSOR
 - (a) Install the sensor with the 2 bolts.
Torque: 19 N*m (194 kgf*cm, 14 ft.*lbf)
 - (b) Connect the sensor connector.
2. INSTALL REAR CONSOLE BOX SUB-ASSEMBLY
(See page [IP-25](#))
3. INSTALL CONSOLE BOX CARPET
4. INSTALL CONSOLE BOX POCKET
5. INSTALL UPPER CONSOLE PANEL SUB-ASSEMBLY
(See page [IP-26](#))
6. PERFORM YAW RATE SENSOR ZERO POINT CALIBRATION
 - (a) Perform the yaw rate sensor zero point calibration (see page [BC-21](#)).
7. CHECK AND CLEAR DTC
 - (a) Check and clear the DTC (see page [BC-38](#)).

STEERING ANGLE SENSOR

COMPONENTS

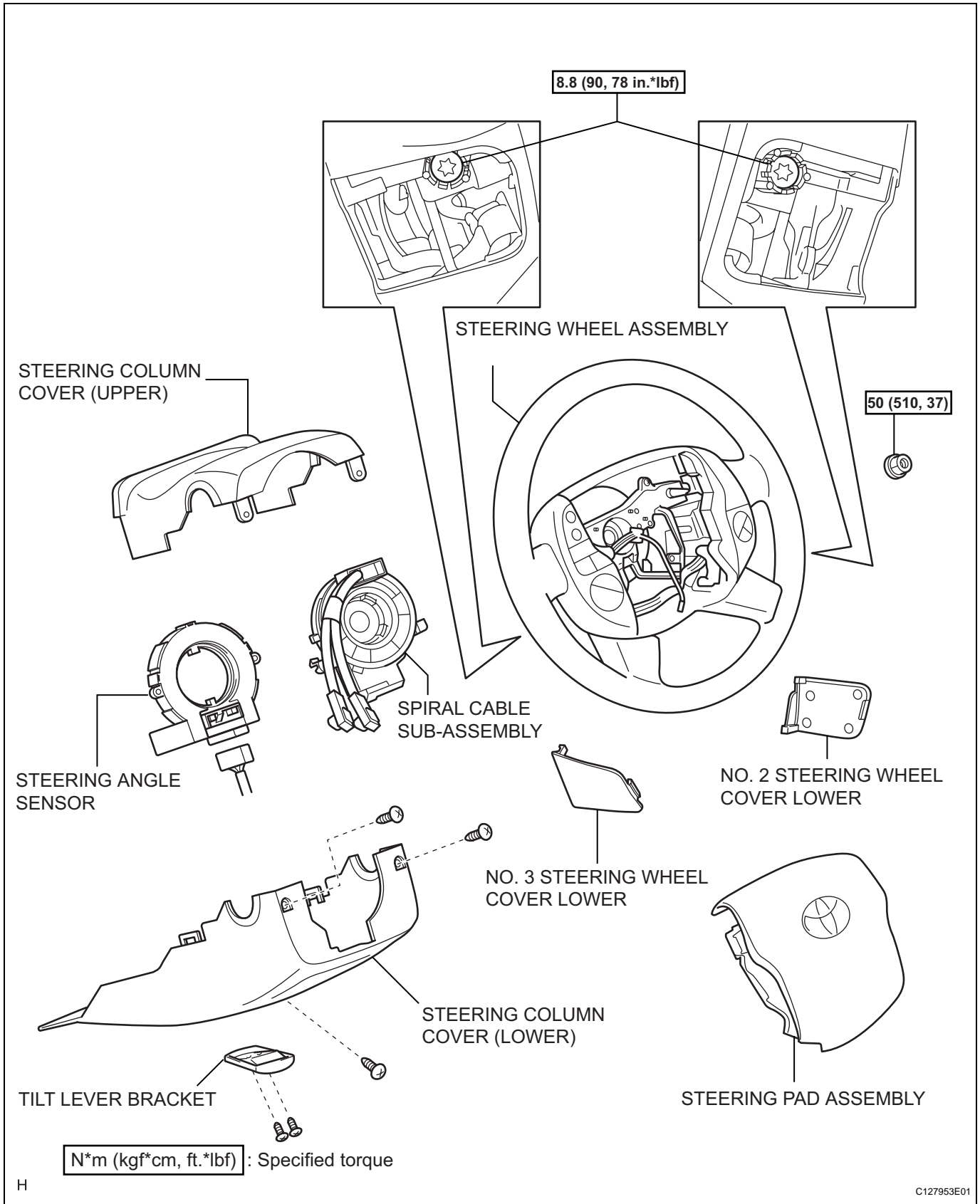

BC

REMOVAL

1. **DISCONNECT CABLE FROM NEGATIVE BATTERY TERMINAL**
CAUTION:
Wait at least 90 seconds after disconnecting the cable from the negative (-) battery terminal to prevent airbag and seat belt pretensioner activation.
2. **REMOVE NO. 2 STEERING WHEEL COVER LOWER**
3. **REMOVE NO. 3 STEERING WHEEL COVER LOWER**
4. **REMOVE STEERING PAD ASSEMBLY** (See page [RS-268](#))
5. **REMOVE STEERING WHEEL ASSEMBLY** (See page [SR-8](#))
6. **REMOVE TILT LEVER BRACKET** (See page [SR-8](#))
7. **REMOVE STEERING COLUMN COVER** (See page [SR-8](#))
8. **REMOVE SPIRAL CABLE SUB-ASSEMBLY** (See page [RS-278](#))
9. **REMOVE STEERING ANGLE SENSOR**
(a) Detach the 6 claws and remove the sensor from the spiral cable.

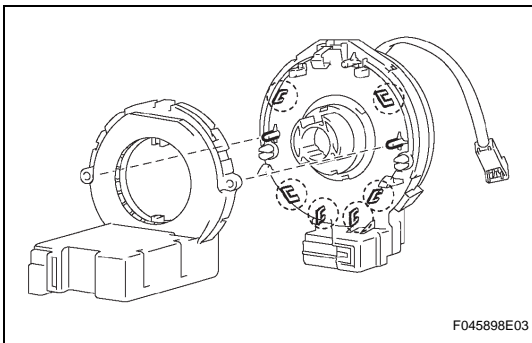
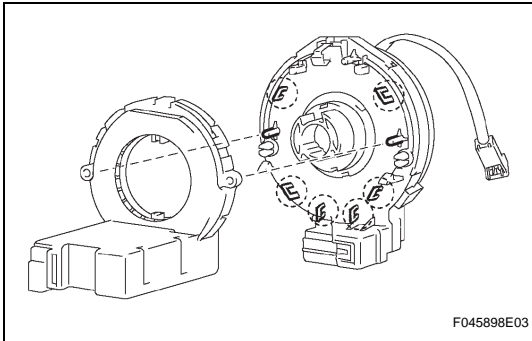

INSTALLATION

1. **INSTALL STEERING ANGLE SENSOR**
(a) Align the locating pins, attach the 6 claws and install the sensor to the spiral cable.
2. **INSPECT SPIRAL CABLE SUB-ASSEMBLY** (See page [RS-278](#))
3. **INSTALL SPIRAL CABLE SUB-ASSEMBLY** (See page [RS-278](#))
4. **INSTALL STEERING COLUMN COVER** (See page [SR-14](#))
5. **POSITION SPIRAL CABLE** (See page [RS-279](#))
6. **INSTALL TILT LEVER BRACKET** (See page [SR-14](#))
7. **INSPECT STEERING WHEEL CENTER POINT** (See page [SR-15](#))
8. **INSTALL STEERING WHEEL ASSEMBLY** (See page [SR-15](#))

9. **INSTALL STEERING PAD ASSEMBLY** (See page [RS-269](#))
10. **INSPECT STEERING PAD ASSEMBLY**
 - (a) Inspect the steering pad (see page [RS-267](#)).
11. **CONNECT CABLE TO NEGATIVE BATTERY TERMINAL**
12. **PERFORM INITIALIZATION**
 - (a) Perform initialization (see page [IN-32](#)).
NOTICE:
Certain systems need to be initialized after disconnecting and reconnecting the cable from the negative (-) battery terminal.
13. **CHECK SRS WARNING LIGHT**
 - (a) Check the SRS warning light (see page [RS-41](#)).

SKID CONTROL ECU

COMPONENTS

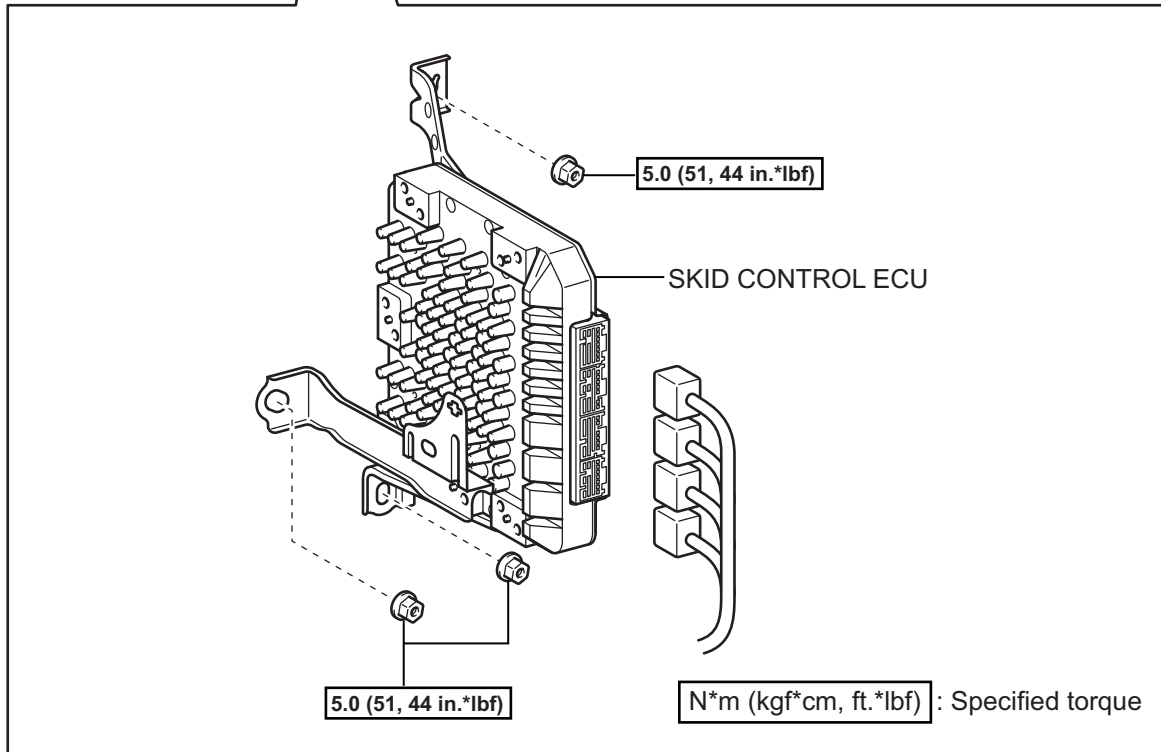
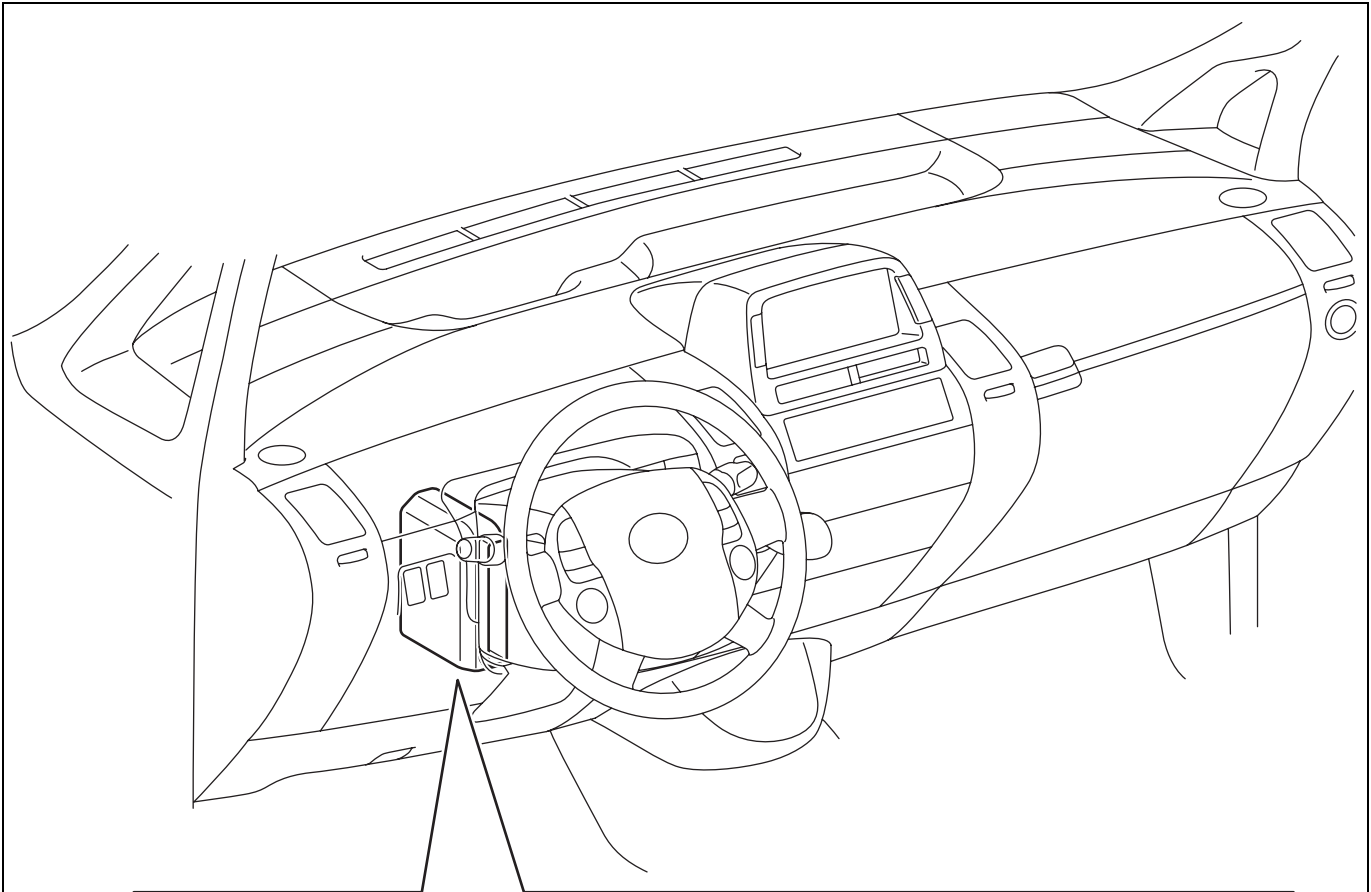

BC

REMOVAL

1. **DISCONNECT CABLE FROM NEGATIVE BATTERY TERMINAL**

CAUTION:

Wait at least 90 seconds after disconnecting the cable from the negative (-) battery terminal to prevent airbag and seat belt pretensioner activation.

2. **REMOVE STEERING COLUMN ASSEMBLY**

- (a) Remove the steering column (see page [SR-7](#)).

HINT:

Refer to the procedures from the removal of the No 2. rear floor board up until the removal of the steering column assembly.

3. **REMOVE SKID CONTROL ECU**

- (a) Remove the wire harness clamp and skid control buzzer from the skid control ECU bracket.
- (b) Disconnect the 4 skid control ECU connectors.
- (c) Remove the 3 nuts and skid control ECU.

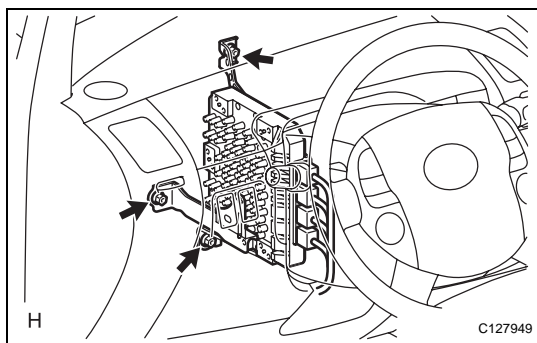
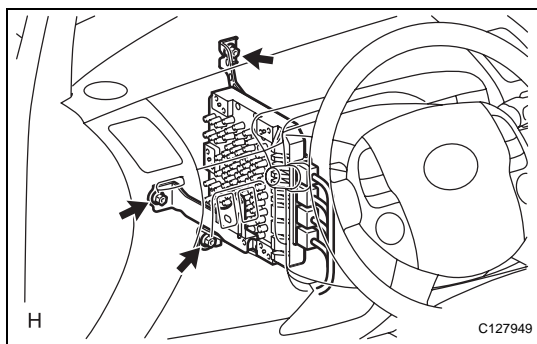

INSTALLATION

1. **INSTALL SKID CONTROL ECU**

- (a) Install the skid control ECU with the 3 nuts.
Torque: 5.0 N*m (51 kgf*cm, 44 in.*lbf)
- (b) Connect the 4 skid control ECU connectors.
- (c) Install the wire harness clamp and skid control buzzer to the skid control ECU bracket.

2. **INSTALL STEERING COLUMN ASSEMBLY**

- (a) Install the steering column (see page [SR-12](#)).

HINT:

Refer to the procedures from the installation of the steering column assembly up until the installation of the No 2. rear floor board.

3. **CONNECT CABLE TO NEGATIVE BATTERY TERMINAL**

4. **INSPECT SRS WARNING LIGHT (See page [RS-269](#))**

5. **PERFORM INITIALIZATION**

- (a) Perform initialization (see page [IN-32](#)).

NOTICE:

Certain systems need to be initialized after disconnecting and reconnecting the cable from the negative (-) battery terminal.

6. PERFORM SYSTEM INITIALIZATION

- (a) Perform the brake system initialization (see page [BC-19](#)).

7. PERFORM YAW RATE SENSOR ZERO POINT CALIBRATION

- (a) Perform the yaw rate sensor zero point calibration (see page [BC-21](#)).

8. CHECK AND CLEAR DTC

- (a) Check and clear the DTCs (see page [BC-38](#)).

BRAKE CONTROL POWER SUPPLY

COMPONENTS

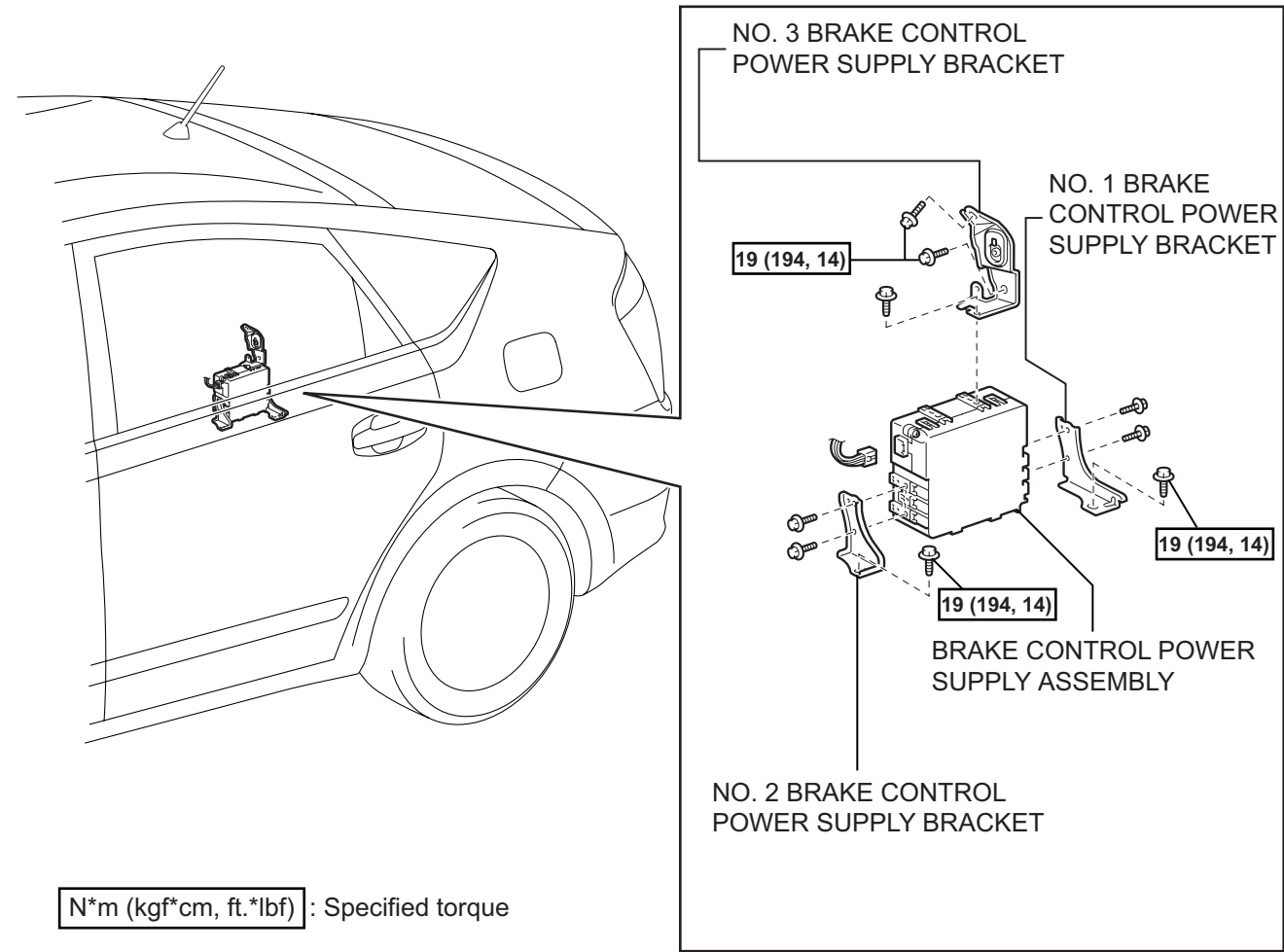
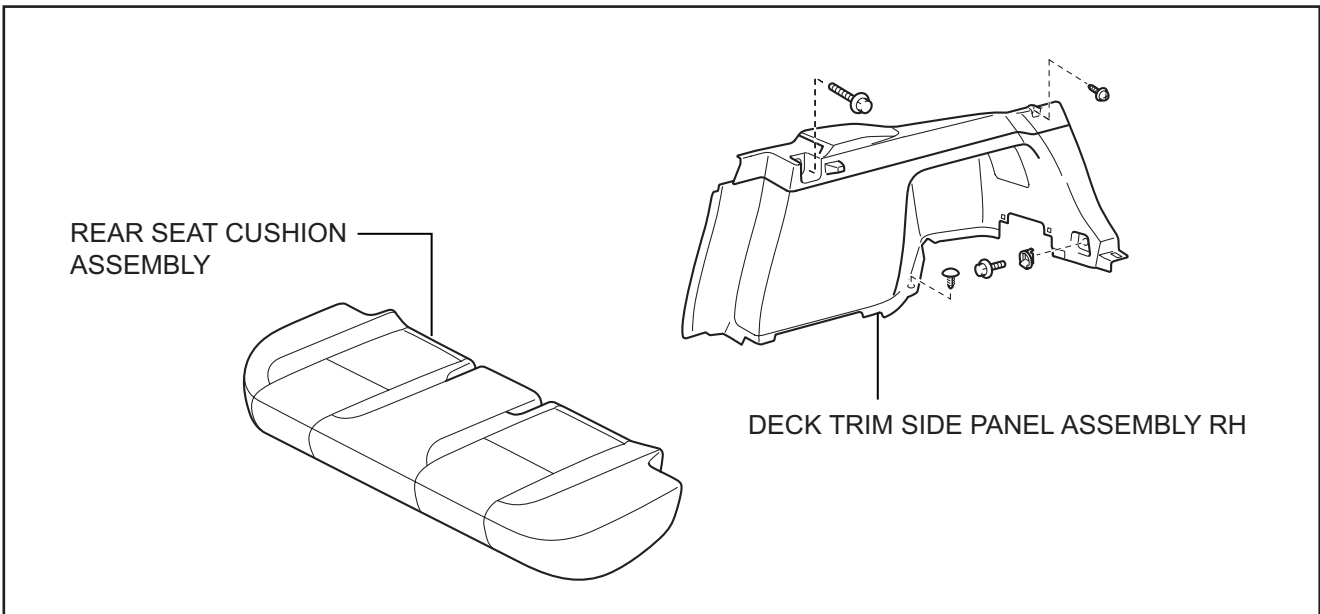

BC

REMOVAL

1. REMOVE REAR SEAT CUSHION ASSEMBLY (See page [SE-15](#))
2. REMOVE DECK TRIM SIDE PANEL ASSEMBLY RH
 - (a) Remove the deck trim side panel RH (see page [IR-7](#)).

HINT:

Refer to the procedures from the removal of the rear door scuff plate RH up until the removal of the deck trim side panel assembly RH.

3. REMOVE BRAKE CONTROL POWER SUPPLY ASSEMBLY
 - (a) Disconnect the connector.
 - (b) Remove the 4 bolts and brake control power supply.
4. REMOVE NO. 3 BRAKE CONTROL POWER SUPPLY BRACKET
5. REMOVE NO. 2 BRAKE CONTROL POWER SUPPLY BRACKET
6. REMOVE NO. 1 BRAKE CONTROL POWER SUPPLY BRACKET

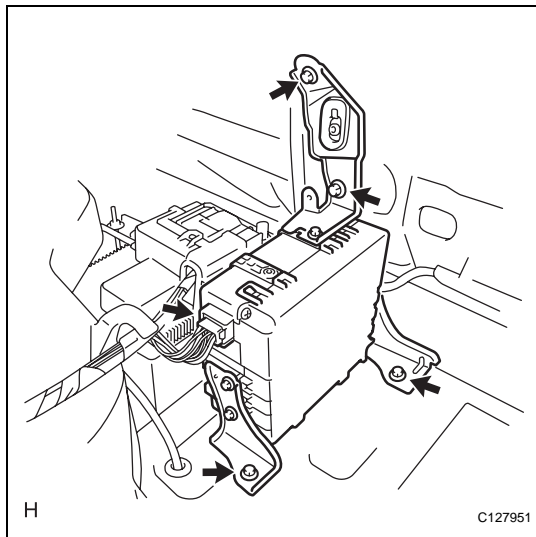

INSTALLATION

1. **INSTALL NO. 1 BRAKE CONTROL POWER SUPPLY BRACKET**
2. **INSTALL NO. 2 BRAKE CONTROL POWER SUPPLY BRACKET**
3. **INSTALL NO. 3 BRAKE CONTROL POWER SUPPLY BRACKET**
4. **INSTALL BRAKE CONTROL POWER SUPPLY ASSEMBLY**

- (a) Install the brake control power supply with the 4 bolts.
Torque: 19 N*m (194 kgf*cm, 14 ft.*lbf)
- (b) Connect the brake control power supply connector.

5. **INSTALL DECK TRIM SIDE PANEL ASSEMBLY RH**

- (a) Install the deck trim side panel RH (see page [IR-13](#)).
HINT:
Refer to the procedures from the installation of the deck trim side panel assembly RH up until the installation of the rear door scuff plate RH.

6. **INSTALL REAR SEAT CUSHION ASSEMBLY (See page [SE-23](#))**

7. **CHECK AND CLEAR DTC**

- (a) Check and clear the DTC (see page [BC-38](#)).

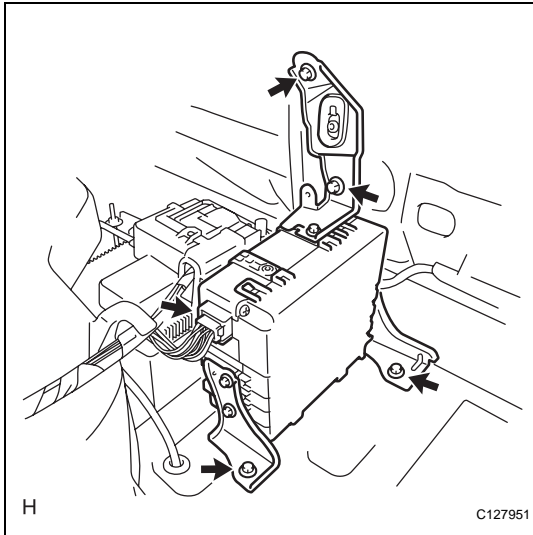

BRAKE PEDAL STROKE SENSOR

COMPONENTS

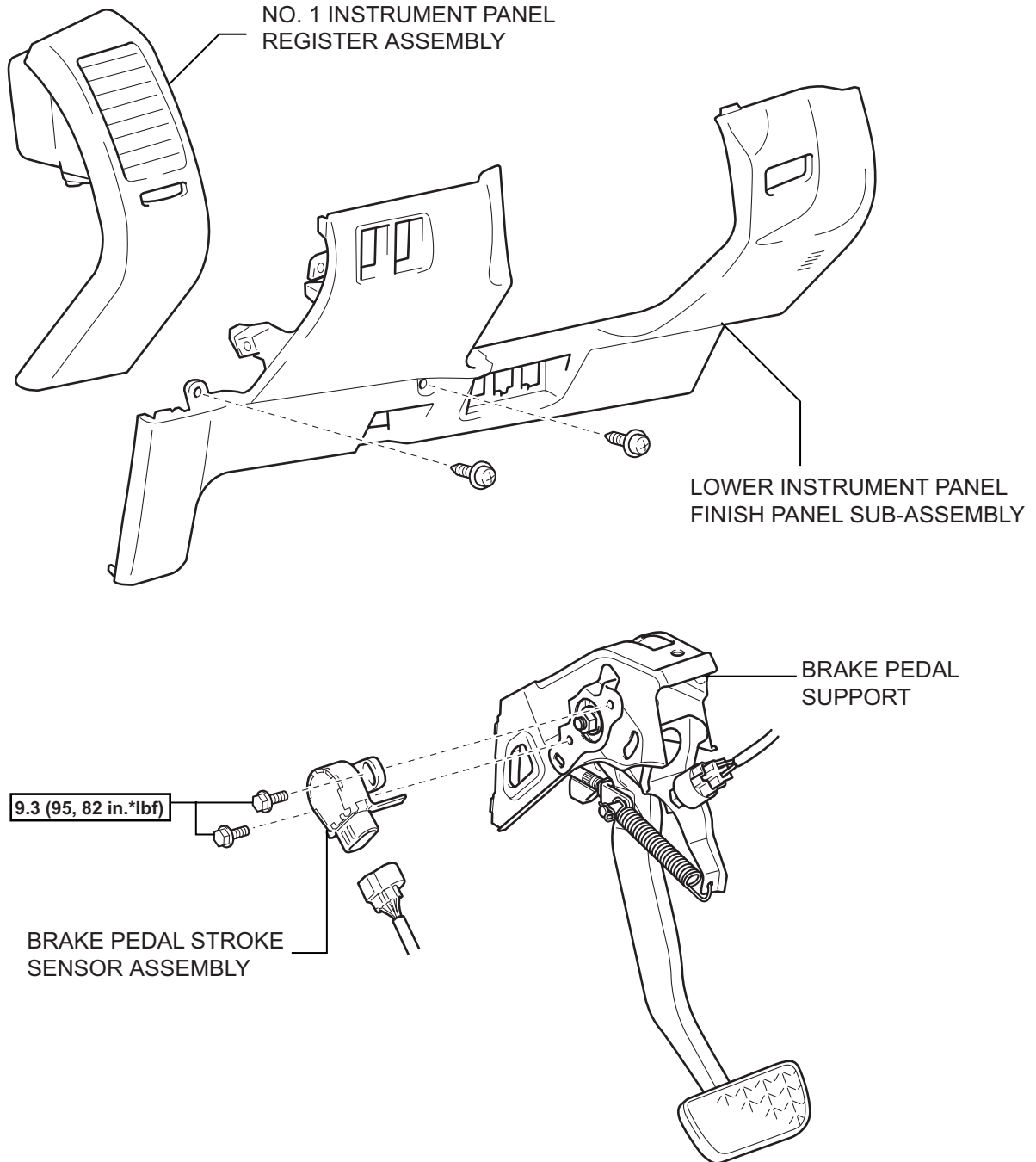

N*m (kgf*cm, ft.*lbf) : Specified torque

BC

REMOVAL

1. REMOVE NO. 1 INSTRUMENT PANEL REGISTER ASSEMBLY (See page IP-5)
2. REMOVE LOWER INSTRUMENT PANEL FINISH PANEL SUB-ASSEMBLY (See page IP-6)
3. REMOVE BRAKE PEDAL STROKE SENSOR ASSEMBLY
 - (a) Disconnect the sensor connector.
 - (b) Remove the 2 bolts and sensor.

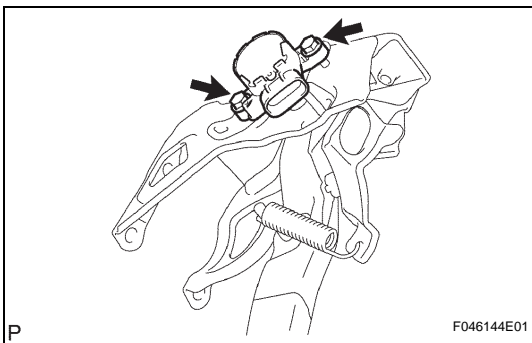
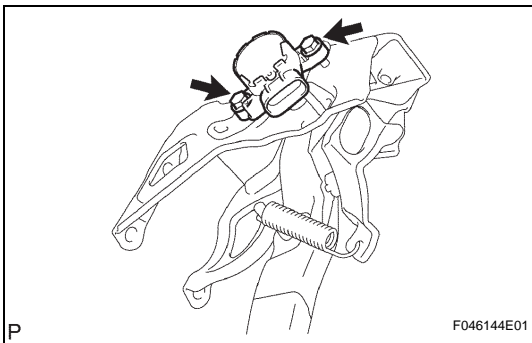
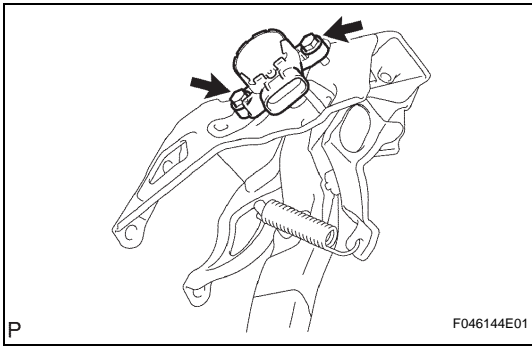

INSTALLATION

1. INSTALL BRAKE PEDAL STROKE SENSOR ASSEMBLY

- (a) When installing a new brake pedal stroke sensor:
 - (1) Install the sensor to the brake pedal support with the 2 bolts.

Torque: 9.3 N*m (95 kgf*cm, 82 in.*lbf)

NOTICE:

- Engage the sensor lever with the brake pedal groove.
 - Check that there is no foreign matter attached to the sensor's contacting surface.
- (2) Strongly depress the brake pedal and break the sensor lever set pin.
 - (3) Remove the broken sensor lever set pin.
 - (4) Connect the sensor connector.
- (b) When reusing the brake pedal stroke sensor:
 - (1) Temporarily install the sensor to the brake pedal support with the 2 bolts.
- NOTICE:**
- Engage the sensor lever with the brake pedal groove.
 - Check that there is no foreign matter attached to the sensor's contacting surface.
- (2) Connect the intelligent tester to the DLC3.
 - (3) Connect the sensor connector.

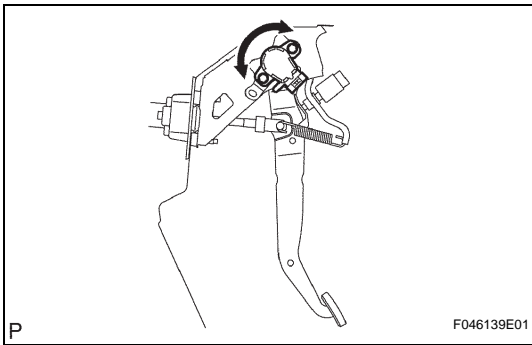

- (4) Turn the power switch ON (IG). Reading the stroke sensor 1 value, turn the sensor slowly to the right and left to adjust it to the standard value.

Standard voltage:

0.8 to 1.2 V

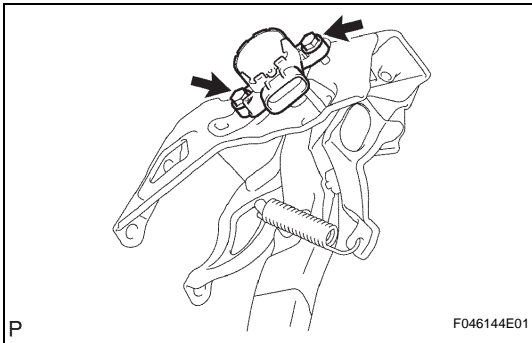

- (5) Tighten the 2 bolts.

Torque: 9.3 N*m (95 kgf*cm, 82 in.*lbf)

NOTICE:

Do not depress the brake pedal after turning the power switch ON (IG).

- (c) Carry out system initialization (see page [BC-19](#)).

2. **INSTALL LOWER INSTRUMENT PANEL FINISH PANEL SUB-ASSEMBLY (See page [IP-13](#))**
3. **INSTALL NO. 1 INSTRUMENT PANEL REGISTER ASSEMBLY (See page [IP-13](#))**