

---

## DR 1.0 EV Schema Elettrico





**Version Description****Version Modification and Description**

Ver- sion	Prepared by	Date	Content	Modification from Last Version	Applicable Model and Configuration
Ver- sion 00	Technical Support Dept.	3/21/2022	Circuit Diagram	Version 00	DR 1.0 EV

**Description:**

1. **Wiring harness part numbers in the diagram are for reference only and vary according to model configuration. If dealer orders wiring harness, check Replacement Part Manual for the corresponding part number.**
2. **If you find any omission or error in this manual, if you have any question, please contact us by phone.**

**Must not copy, translate or extract the manual without our written permission. We express clearly all rights relating to copyright as provided by law are reserved.**

**DIRECTORY**

<b>How to Use This Manual</b> .....	<b>3</b>
Diagram Example .....	3
Description of Main Symbols in Circuit Diagram.....	4
Wire Harness Connector Definition .....	5
Abbreviation .....	6
<b>Troubleshooting</b> .....	<b>7</b>
Troubleshooting Tool .....	7
Electrical Malfunction Troubleshooting .....	7
<b>Fuse and Relay Information</b> .....	<b>10</b>
Front Compartment Fuse and Relay Box .....	10
Front Compartment Fuse and Relay Box .....	12
Meter Fuse and Relay Box.....	15
<b>Power Distribution Center</b> .....	<b>18</b>
<b>Control Module Distribution Diagram and Terminal Definition</b> .....	<b>23</b>
Module Terminal Definition .....	23
<b>Ground Point</b> .....	<b>28</b>
Ground Points Layout.....	28
Ground Point Definition.....	28
<b>Wire Harness Position Diagram</b> .....	<b>38</b>
Vehicle Wiring Harness Layout Diagram .....	38
Wire Harness Connector Location in Real Vehicle .....	39
Front Cabin Wiring Harness Assembly .....	43
Instrument Panel Wire Harness Connector Location Diagram .....	44
Interior Floor Wire Harness Connector Location Diagram.....	47
Left Door Wire Harness Connector Location Diagram .....	51
Right Door Wire Harness Connector Location Diagram.....	52
Back Door Wire Harness Connector Location Diagram .....	53
Rear Bumper Wire Harness Connector Location Diagram .....	54
Position Diagram Of Battery Negative Wire Harness.....	55
DCDC Ground .....	56
DC+ Wire Harness Connector .....	57

**System Circuit Diagram..... 59**

- High Voltage Supply System .....59
- High Pressure Interlock.....60
- Battery and Vehicle Charger (DCDC).....61
- Battery Charging .....62
- BCM.....63
- VCU .....77
- EPB.....80
- EPS&SAS&YAS .....81
- ESC Controller.....82
- Electric Rearview Mirror.....83
- Power Seat .....85
- A/C Controller System.....86
- Instrument Cluster .....88
- Audio Entertainment System.....89
- Airbag .....90
- Pedestrian Alert, Tire Pressure Monitoring, Reversing Radar.....91
- Wireless Charging, Backup Power Supply.....92
- Network Topology Diagram.....93

# How to Use This Manual

## Diagram Example

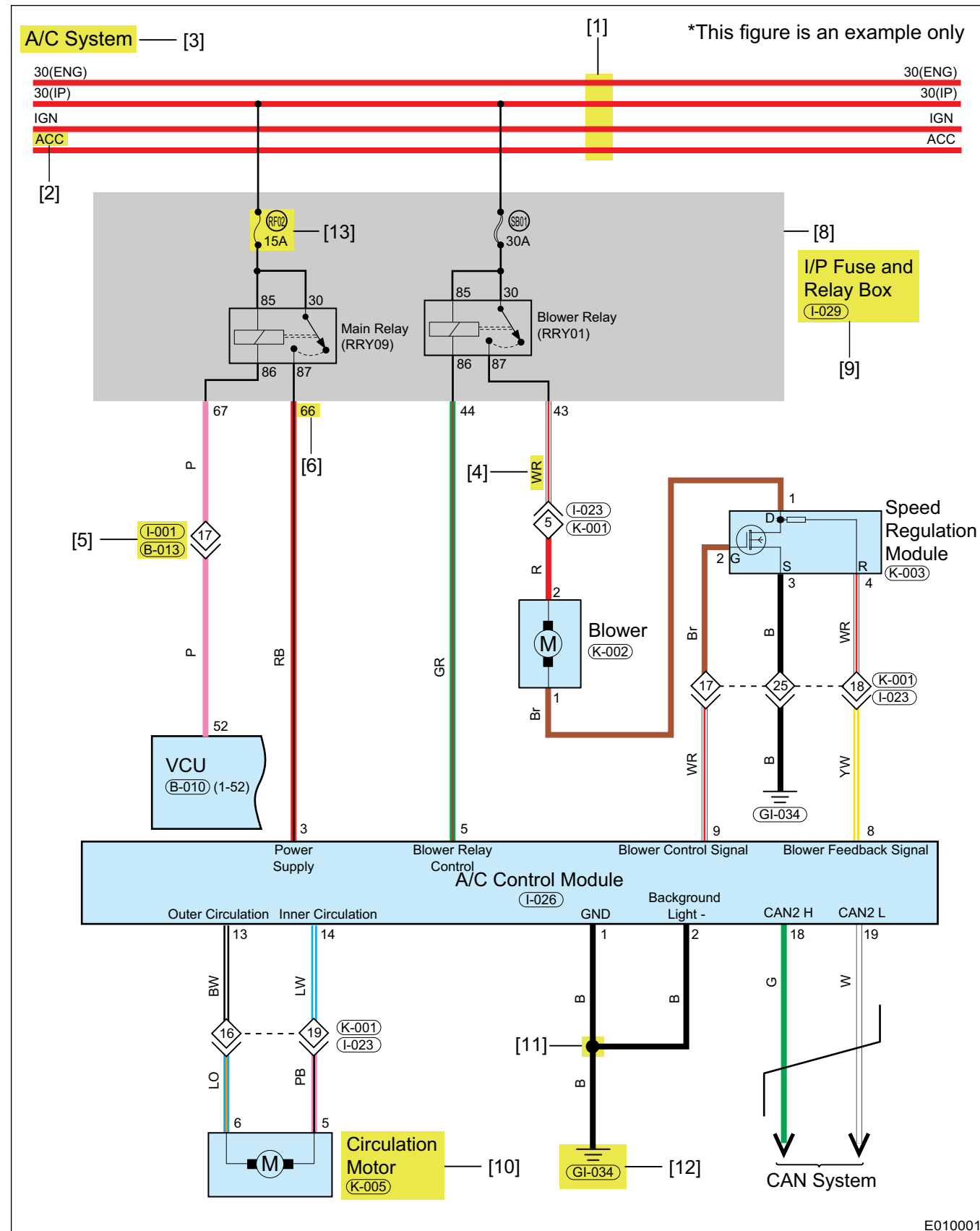

## How to Use This Manual

[7] Fuse in front compartment fuse and relay box.

No.	Definition	Example
1	Chip fuse in front compartment fuse and relay box is represented by EF + number	EF05 10A represents 10A chip fuse with number 05 in front compartment fuse and relay box
2	Slow blow fuse in front compartment fuse and relay box is represented by SB + number	SB01 30A represents 30A slow blow fuse with number 01 in front compartment fuse and relay box

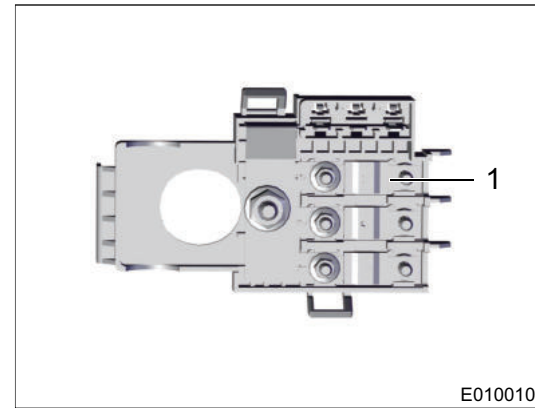

[8] The gray area indicates the inside of fuse and relay box.

[9] The connector number corresponding to I/P relay box connector in circuit diagram.

[10] Electrical components name and circuit diagram number.

[11] Wire splice point.

No.	Definition
1	Wires Connected
2	Wires not Connected

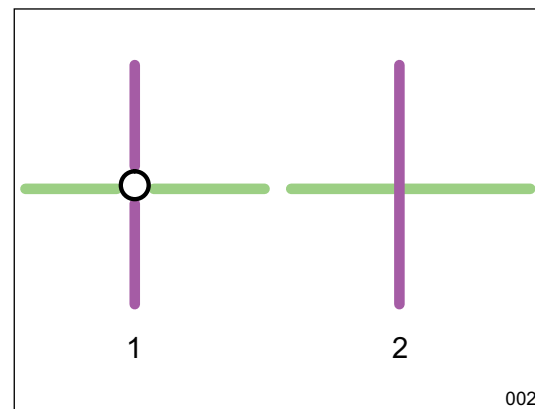

[12] GI-034 is a number of ground connector of the back door wire harness. In which, "G" indicates ground, "I" indicates instrument panel wire harness, "034" indicates the number of this wire connector. For detailed ground point location symbol, refer to section "Ground Points Layout".

[13] Fuse in instrument panel fuse and relay box.

No.	Definition	Example
1	Chip fuse in instrument panel fuse and relay box is represented by RF + number	RF02 10A represents 10A chip fuse with number 02 in instrument panel fuse and relay box

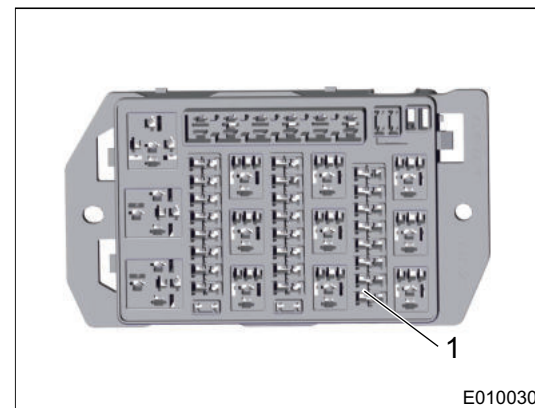

## Description of Main Symbols in Circuit Diagram

	<b>BATTERY</b> Stores chemical energy and converts it into electrical energy. Provides DC current for the auto's various electrical circuits.		<b>GROUND</b> The point at which wiring attaches to the Body, thereby providing a return path for an electrical circuit; without a ground, current cannot flow.
	<b>RELAY</b> An electrically operated switch. Current flow through a small coil creates a magnetic field which either opens or closes an attached switch.		<b>WIRES</b> Crossed wires [1] without a black dot at the junction are not joined; crossed wires [2] with a black dot at the junction are spliced (joined) connections.
	<b>MOTOR</b> A power unit which converts electrical energy into mechanical energy, especially rotary motion.		<b>FUSE</b> A thin metal strip which burns through when too much current flows through it, thereby stopping current flow and protecting a circuit from damage.
	<b>SWITCH</b> Opens and closes circuits, thereby stopping [1] or allowing [2] current flow.		<b>TWISTED-PAIR LINE</b> Two wires are twisted together to transmit signals.
	<b>SPEAKER</b> An electromechanical device which creates sound waves from current flow.		<b>SOLENOID</b> An electromagnetic coil which forms a magnetic field when current flows, to move a plunger, etc.
	<b>HORN</b> An electric device which sounds a loud audible signal.		<b>CIGARETTE LIGHTER</b> An electric resistance heating element.
	<b>IGNITION COIL</b> Converts low-voltage DC current into high-voltage ignition current for firing the spark plugs.		<b>LED</b> Upon current flow, these diodes emit light without producing the heat of a comparable light.
	<b>LIGHT</b> Current flow through a filament causes the filament to heat up and emit light.		<b>RESISTOR</b> An electrical component with a fixed resistance, placed in a circuit to reduce voltage to a specific value.
	<b>HEATING WIRE</b> An electric resistance heating element.		



## Wire Harness Connector Definition

### 1. Wire Harness Connector Definition

Electrical components and wire harness or different wire harnesses are connected by connectors, which consist of cover, male (pin terminal) or female (hole terminal), seals and wire etc:

No.	Definition	No.	Definition
1	Multi-wire Seal	2	Male
3	Female	4	Single Wire Seal
5	Cover	6	Cover Seal
7	Connector	8	Wire Harness Connection
9	Wire	10	Conductor

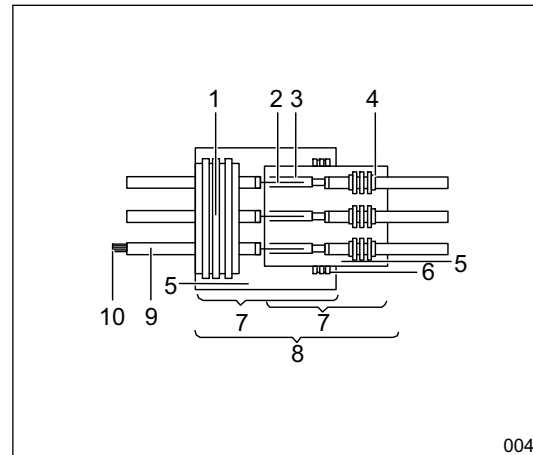

004

- (1) View direction of wire harness connector in electrical wiring diagram:

Meaning of number on multi-wire connector cover: number such as 1, 2, 3 etc. indicates pin (hole) number of connector. Only the first and last number in a row of pins (holes) are provided in definition. Terminal view and description in detail of connectors are provided in wire harness diagrams in following sections.

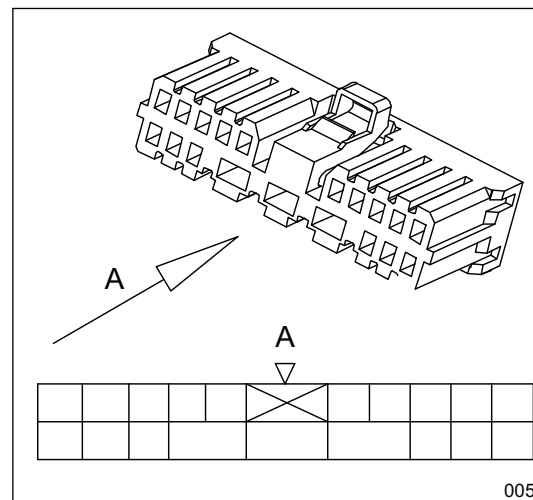

005

- (2) Explanation for pin and hole terminal of connector:

Connector pin side: connector side with pin is defined as pin side, also called male side.

Connector hole side: connector side with hole is defined as hole side also called female side.

Pin and hole are defined as the following figures:

No.	Definition	No.	Definition
1	Multi-wire Seal	2	Male
3	Female		

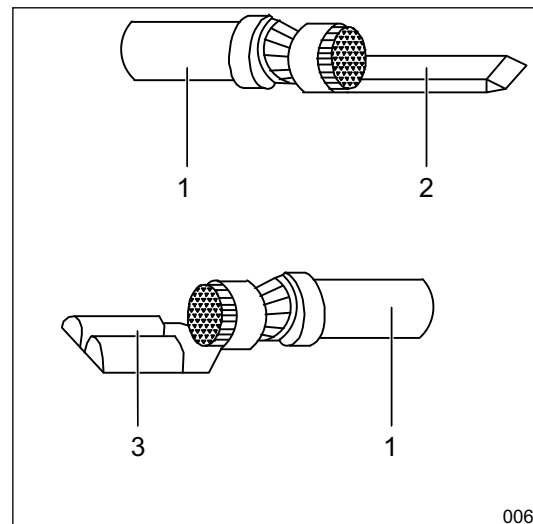

006

- (3) Explanation for terminal of connector connecting wire harness and wire harness in wiring diagram

No.	Definition
1	8th terminal
2	Indicates pin terminal
3	Indicates hole terminal
4	B-037 means interior floor wire harness connector No.37
5	I-014 means instrument panel wire harness connector No.14

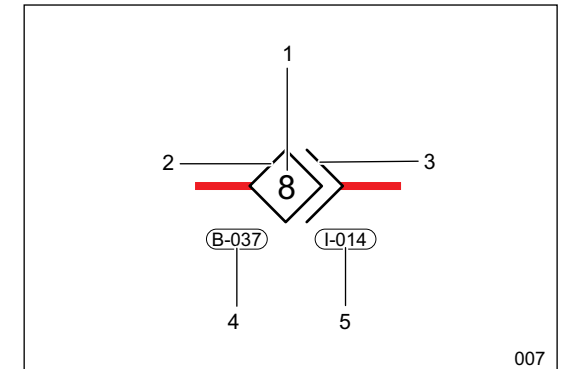

007

Connector Letter Code:

No.	Definition	No.	Definition	No.	Definition
Q	Front Compartment Wire Harness	I	IP Wire Harness	B	Interior Floor Wire Harness
F	Front Left Door Wire Harness	H	Front Right Door Wire Harness	J	Rear Bumper Wire Harness
T	Back Door Wire Harness	P	Battery Positive Wire Harness	GN	Ground Wire Harness

- (4) Representation for connector with no terminal in wire harness diagram

Some terminals in a wire harness connector with no pin (male) or hole (female), i.e. empty, is represented by “-” or “\” .

NOTE: “With or without a terminal” differs according to vehicle configuration. Not all information on this is available in this manual, therefore, terminal views of connectors in wire harness diagrams are for reference only.

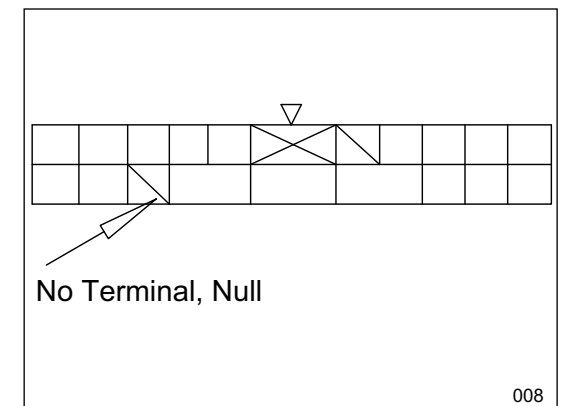

008

## How to Use This Manual

### Abbreviation

Abbreviation	English Full Name
A	Ampere
A/C	Air Conditioning
V	Volt
CGW	Central Gateway
ABS	Anti-lock Break System
ESP	Electronic Stability Program
ABM	Air Bag Module
PEPS	Passive Entry Passive Start
EMS	Engine Management System
TCU	Transmission Control Unit
EPS	Electric Power Steering
EPB	Electrical Park Brake
BSD	Blind Spot Detection
FRM	Front Radar Module
FCM	Front Camera Module
LDW	Lane Depart Warning
SAM	Steering Angle Module
BCM	Body Control Module
AIPM	Integrated Panel Module
RADAR	RADAR
ICM	Instrument Cluster Module
CLM	Climate Module
AVM	Around View Monitor Module
IHU	Infotainment Head Unit
TBOX	Telematics BOX
IMMO	Immobilizer
YAS	Yaw acceleration Sensor
DLC	Data link Connector
GSM	Gear Shift Mode
RSM	Rain Sensor Module
APM	Anti Pinch Control Module
TPMS	Tire Pressure Monitor System

Abbreviation	English Full Name
PLG	Power Lift Gate
EBS	Electric Battery Sensor
IEM	Intelligent Electrical Motor Module
AGS	Active Grill Shutter Module
MFS	Multi Function Switch
KSM	Kick Sensor Module
ESCL	Electrical Steering Column Lock
DHT	Dedicated Hybrid Transmissions
IPB	Integrated Power Brake
CDU	Conversion & Distribution Unit
BMS	Battery Management System
VCU	Vehicle Control Unit
MCU	Micro Controller Unit
HCU	Hybrid Control Unit
ECU	Engine control unit
BCM	Body Control Module



# Troubleshooting

## Troubleshooting Tool

### 1. Jumper Wire

Jumper wires are used to create temporary circuits, and connected between circuit terminals to bypass switches.

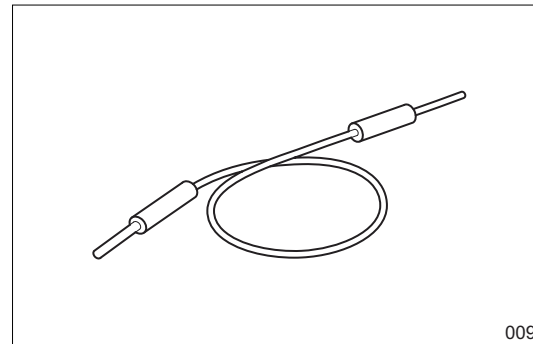

#### Warning

- Do not connect jumper wire from power source end to body ground, otherwise, wire harness or electrical components may be damaged.

### 2. Voltmeter

Voltmeter is used to measure the circuit voltage. Measurement range should be higher than 15 V. Voltage is measured by connecting the positive probe (red) of voltmeter to positive lead of part to be tested and the negative probe (black) to the negative lead or body ground.

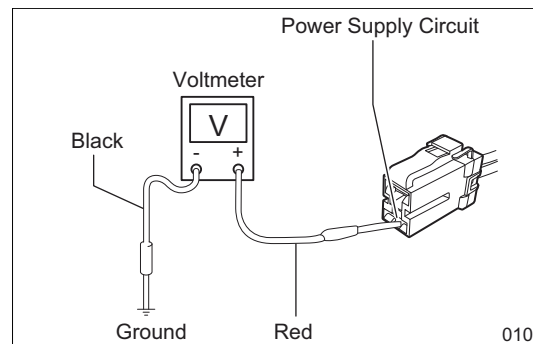

### 3. Ohmmeter

Ohmmeter is used to measure the resistance between two points in a circuit, or to check the circuit for open or short.

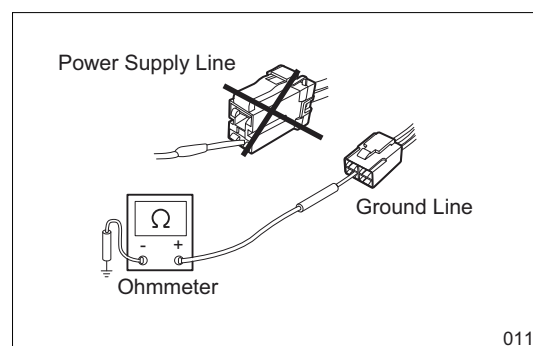

#### Warning

- When applying voltage to the circuit, do not connect ohmmeter to circuit, otherwise the measurement data may be inaccurate or even cause damage to ohmmeter.

## Electrical Malfunction Troubleshooting

### 1. Wire harness troubleshooting

Following 6 steps help to diagnose and troubleshoot wire harnesses. Be sure to check any non-genuine components added to the vehicle before performing any diagnosis. If the vehicle is equipped with such components, disconnect them to confirm that the added components are not the cause of fault. To troubleshoot the wire harness, perform the following steps:

- Confirm problem.
- Look for any related symptoms (by checking components in the same circuit).
- Analyze symptoms (use circuit diagram to determine circuit layout, areas most likely to fail, and areas to proceed with diagnosis).
- Isolate the failure area.
- Repair the failure area.
- Check if it is working properly (in this step, check if all items of repairing circuit are working properly).

### 2. Voltage Check

- Determine conditions in which voltage is present at the check point.

Example:

[A] - Ignition switch ON

[B] - Ignition switch and switch ON

- Using a voltmeter, connect the negative probe (black) to a good ground point or negative battery terminal, and the positive probe (red) to the connector or component terminal.

This check can be done with a test light instead of a voltmeter.

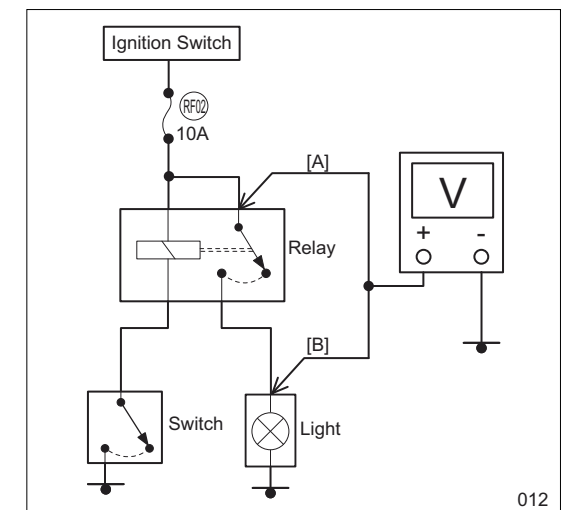

### 3. Continuity Check

- Turn off all electrical appliance and ignition switch, disconnect the negative battery cable.
- Disconnect the circuit to be tested.
- Connect the two probes of ohmmeter to both ends of tested circuit, and check the circuit continuity (lower resistance indicates better circuit continuity).

If the circuit has diodes, reverse the two probes and check again.

When contacting the negative probe (black) to the diode positive side, and the positive probe (red) to the negative side, there should be continuity; When contacting the two probes in reverse, there should be no continuity.

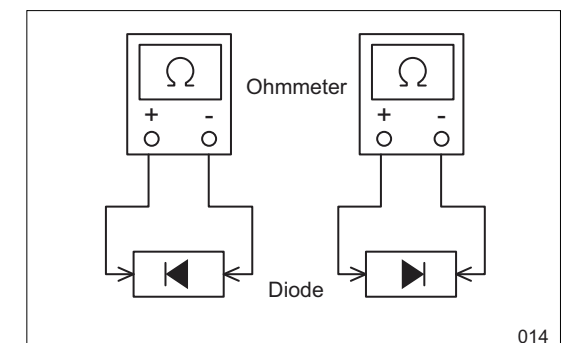
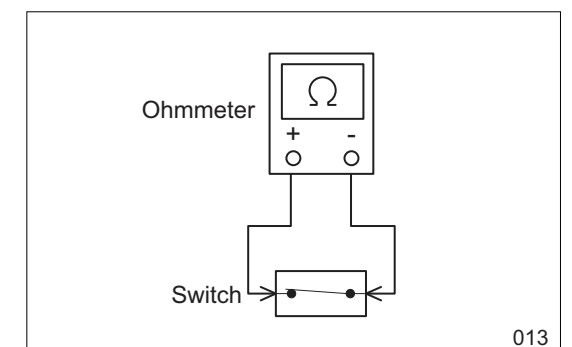

## Troubleshooting

### 4. Short Circuit Check

- (1) Measure and record battery voltage.
- (2) Pull out the fuse of tested circuit or disconnect the power source end of tested circuit.
- (3) Connect the positive probe (red) of voltmeter to the positive battery terminal, and negative probe (black) to power source end of circuit.
- (4) Check the voltage value shown on voltmeter. If voltage value of battery is displayed, it indicates that the test circuit short to the ground.
- (5) This check can be done with a test light instead of a voltmeter.

### 5. Wire Harness Repair

#### ⚠ Caution

- Before repairing, measure the length of wire to be repaired and select a suitable substitute wire.
- If there are multiple wires to be repaired, separate the repaired parts.

- (1) Strip 0.5 inch insulation layer from repair wire and substitute wire.
- (2) Use heat shrink sleeve to connect the original wire and substitute wire, and compress the metal core of heat shrink sleeve with a tool to securely connect the original wire and substitute wire.
- (3) Keep the outer layer of the heat shrink sleeve in a good heat-shrinking state.
- (4) Wrap the repaired wires with insulating tape.

### 6. Fuse Replacement

#### ⚠ Caution

- After replacing the fuse, perform a power on test. If the fuse is blown again, check the corresponding circuit for short. If any electrical equipment or additional equipment that exceeds the rated current is installed, replace the fuse with a higher current.

- (1) Turn off all electrical equipment and ignition switch before repair.
- (2) Remove the blown fuse with fuse puller.
- (3) Replace with a new fuse with same specification.

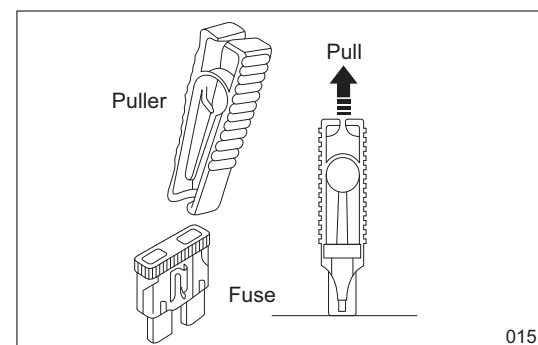

### 7. Electrical Components

- (1) Battery cable.  
Disconnect negative battery cable (arrow) before repairing electrical components.

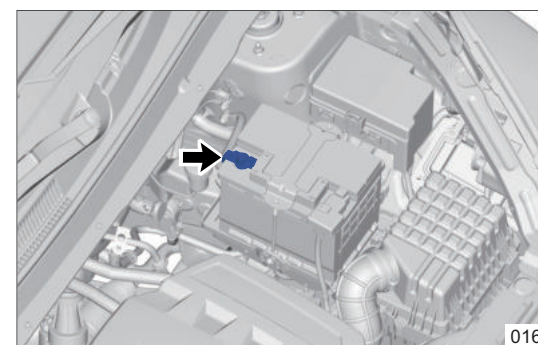

- (2) Sensors, switch and relay

Do not drop or knock sensors, switches or relays during repair, to avoid damaging components.

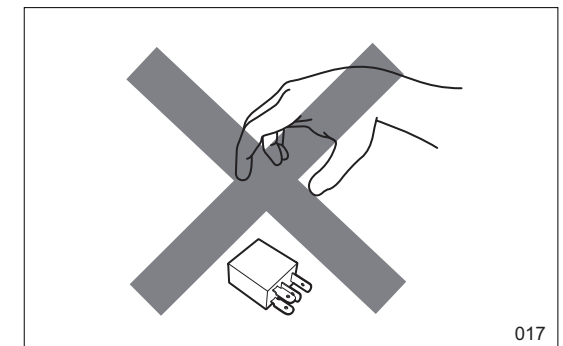

#### ⚠ Caution

- Use relay with same specifications as the original relay during replacement.

- (3) Connector

- Disconnect the connector.  
To pull apart the connectors, pull on the connector itself, and press the connector clip to disconnect.

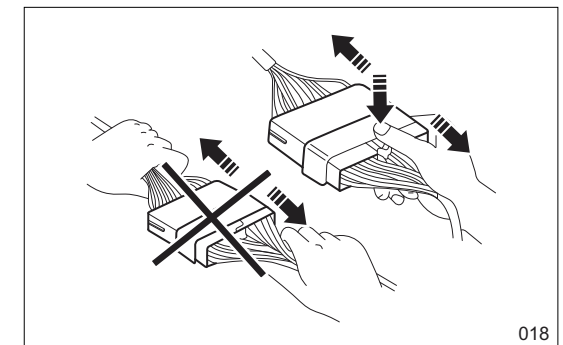

#### ⚠ Caution

- When disconnecting connectors, do not forcibly pull the wire harness to avoid damaging parts.

There are many ways to secure the connector clip. The following figure shows the common disconnection method.

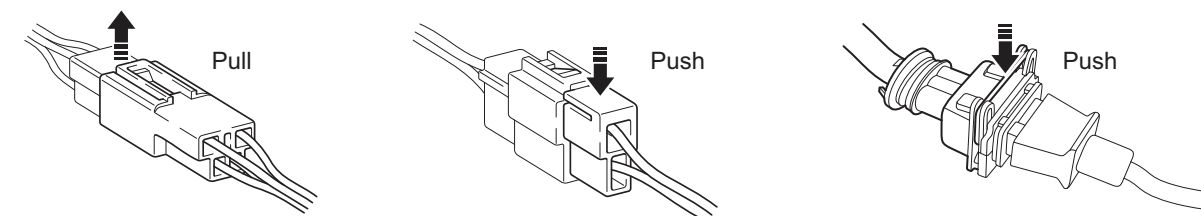
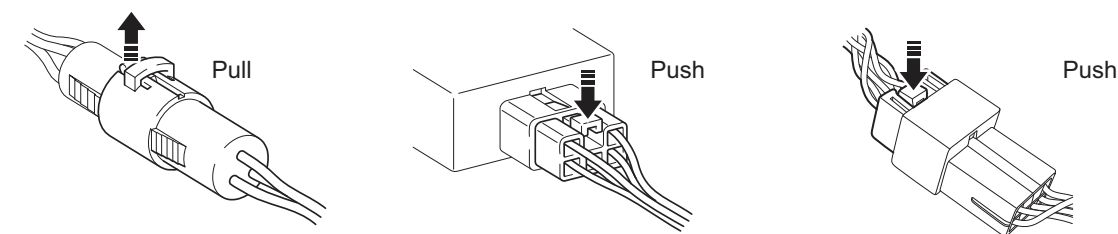

019

- Install the connector.

When the connector is installed in place, a "click" is heard.

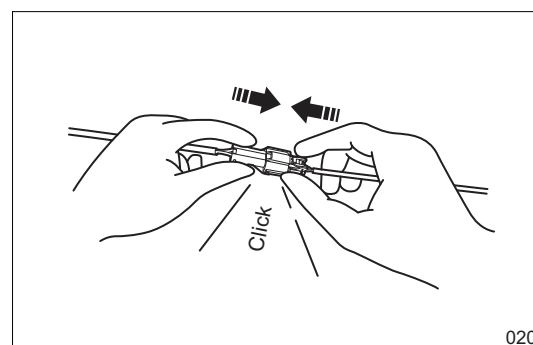

020

- Replace the connector terminal.

As shown in figure (1), insert appropriate tool into the terminal to lift fixing clip, and then pull out terminal from back side. During installation, push the terminal from back of connector to ensure that fixing clip is installed in place, as shown in figure (2).

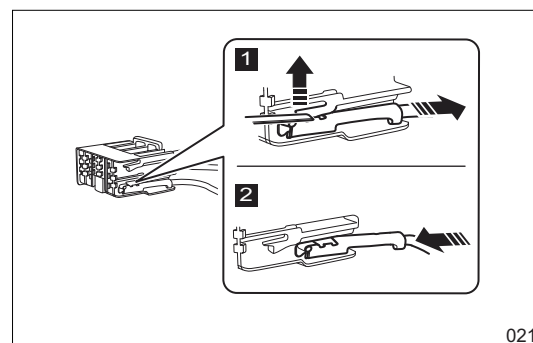

021

- Check the connector terminal.

Gently pull on a single terminal wire to check if it is installed in place.

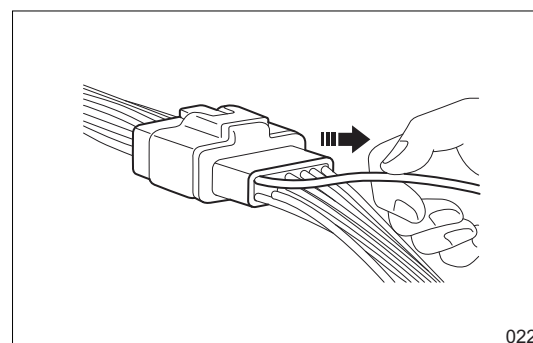

022

## Fuse and Relay Information

### Front Compartment Fuse and Relay Box

#### 1. Front Compartment Fuse and Relay Box Layout

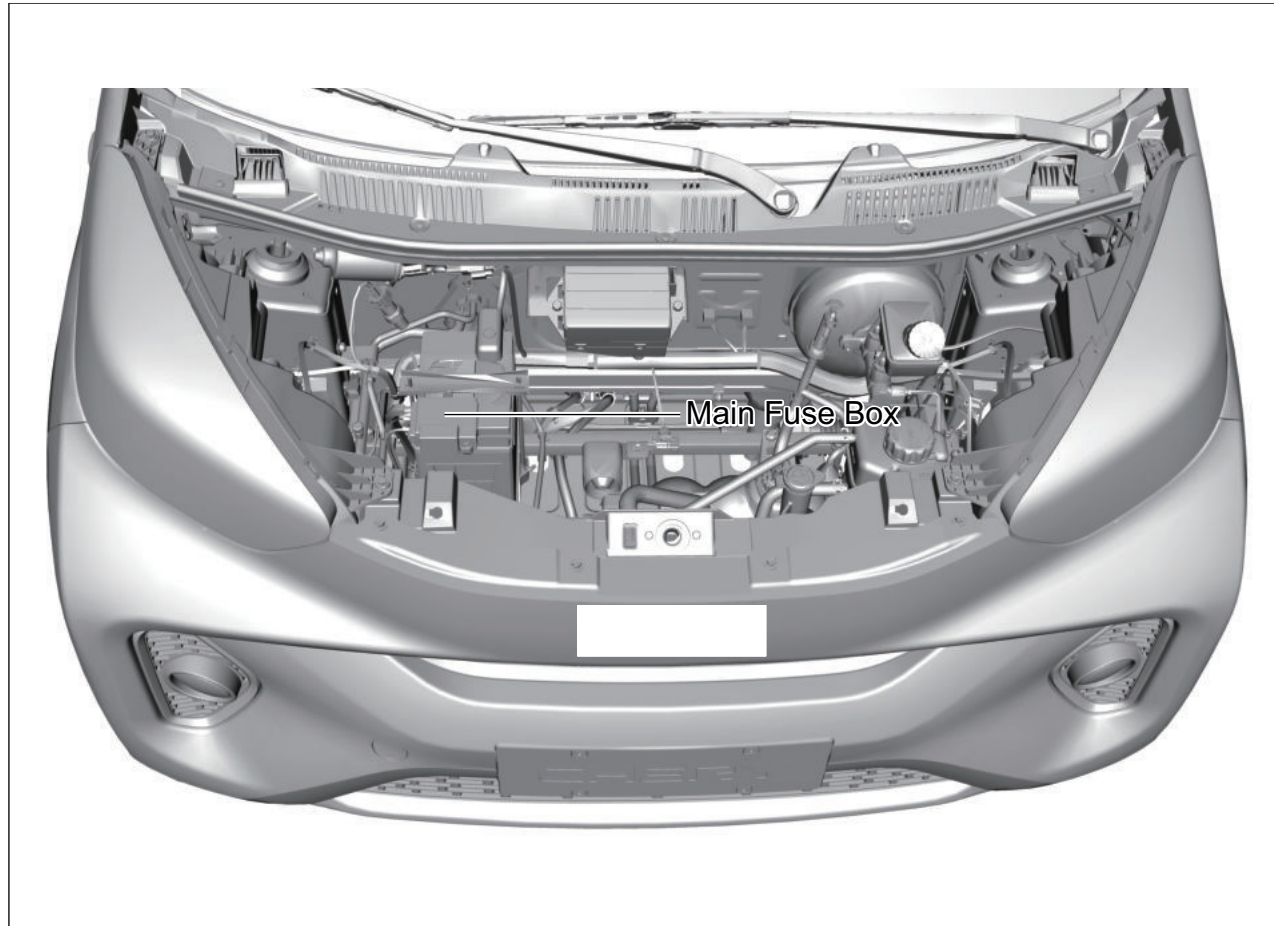

#### 2. Front Compartment Fuse and Relay Box Layout

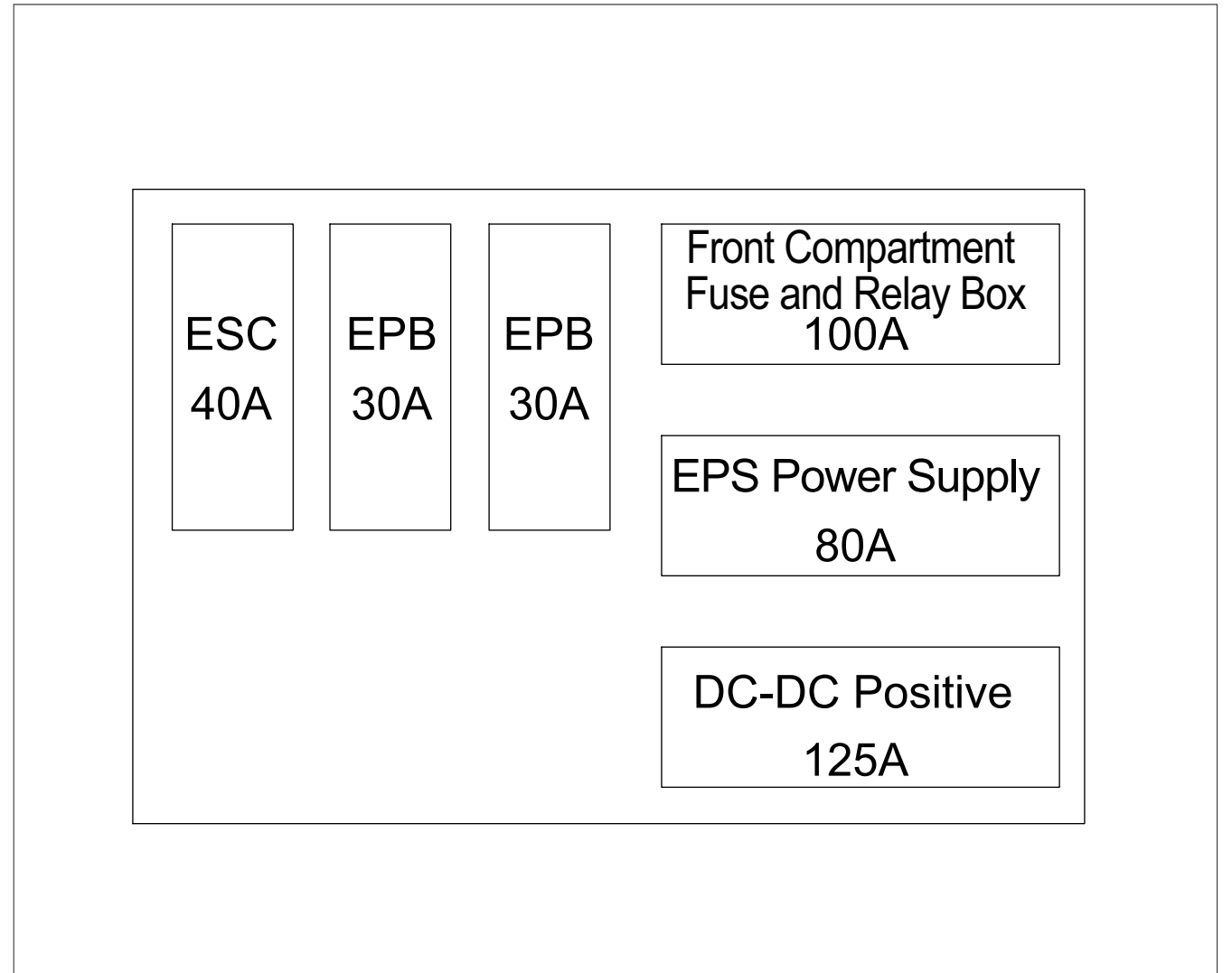

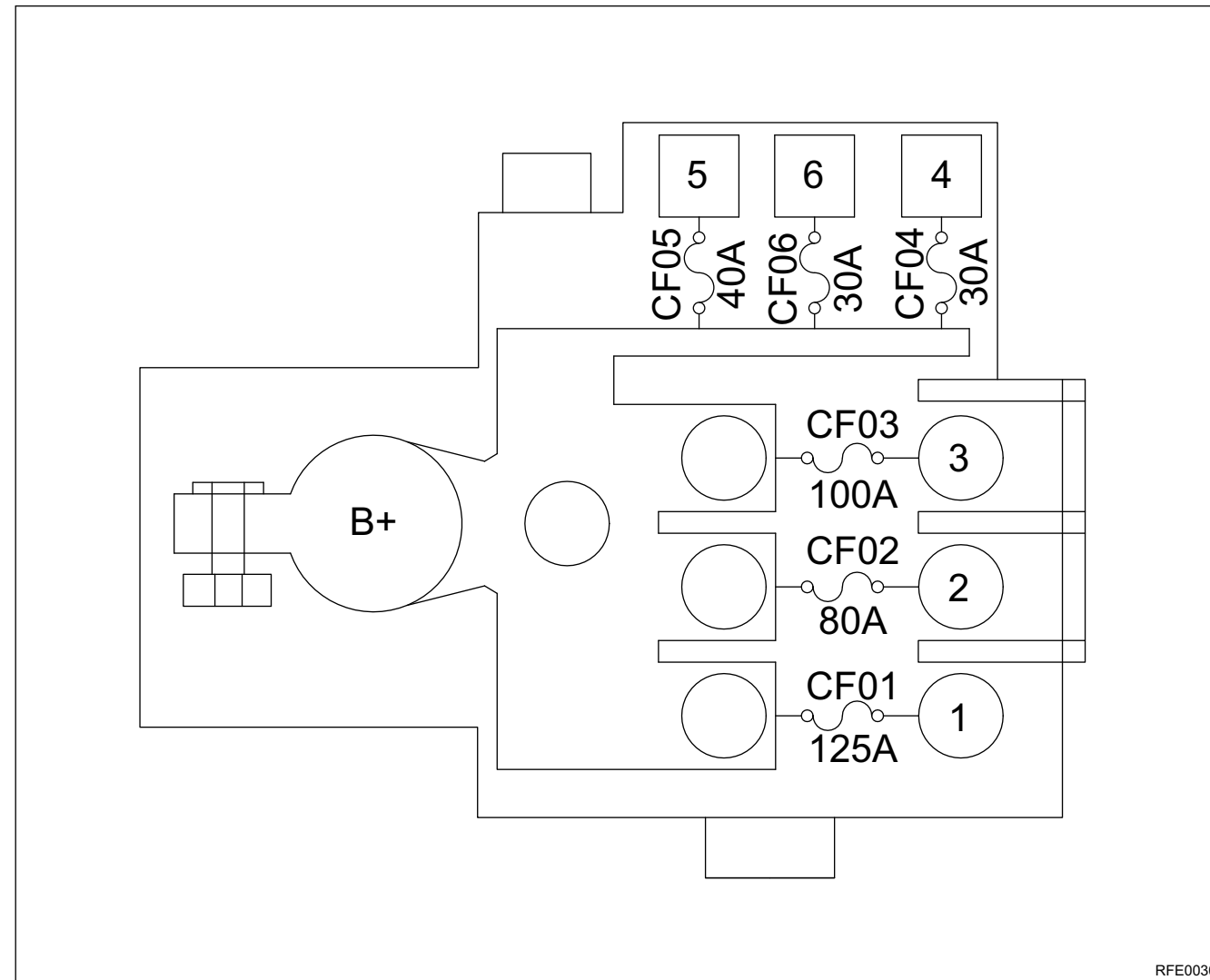

RFE0030

No.	Fuse Name	Fuse Load (A)	Function
1	CF01	125A	DC+
2	CF02	80A	EPS B Power/EPS Control
3	CF03	100A	Front Compartment Fuse and Relay Box
4	CF04	30A	EPB Module - LH
5	CF05	40A	ESC Controller
6	CF06	30A	EPB Module - RH

### 3. Front Compartment Fuse Function Instruction

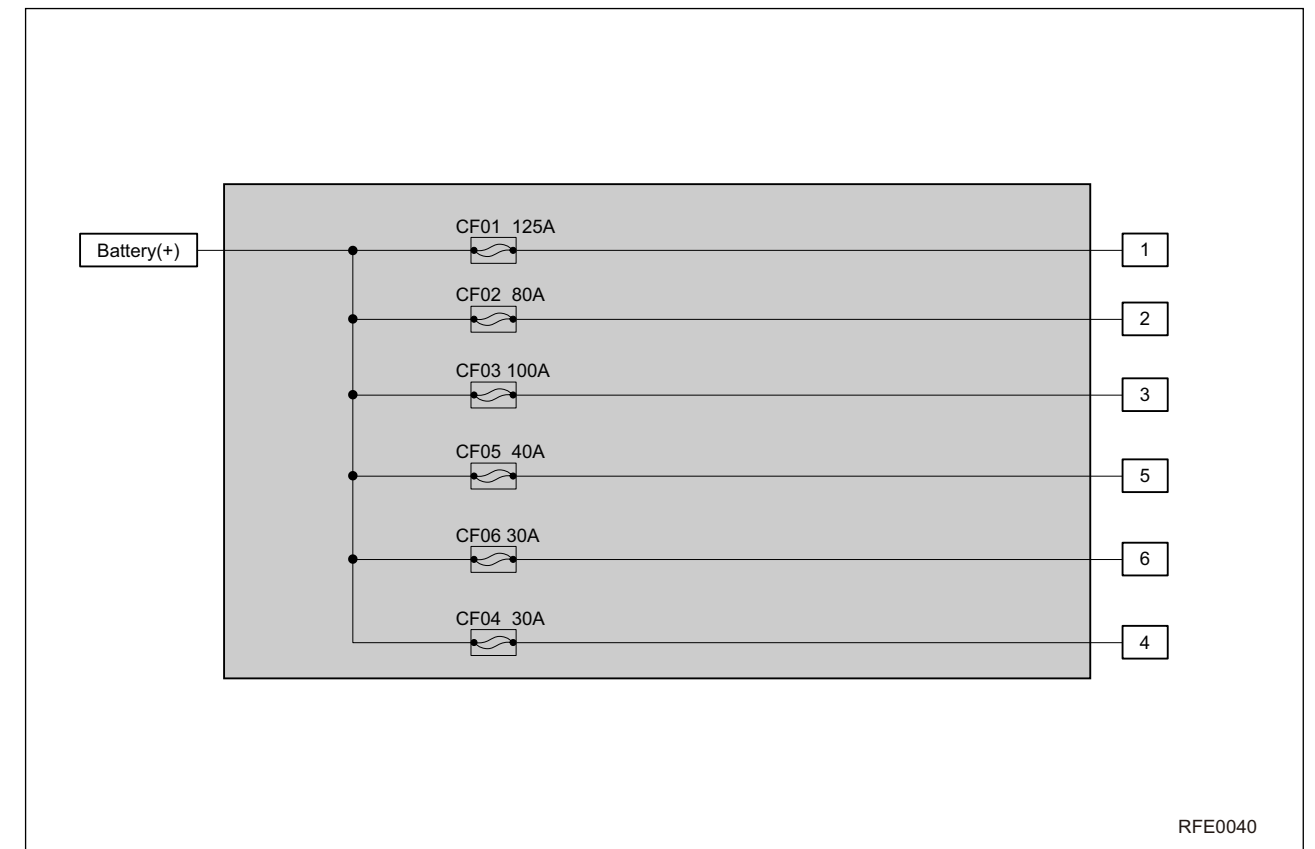

RFE0040



## Front Compartment Fuse and Relay Box

### 1. Front Compartment Fuse and Relay Box Layout

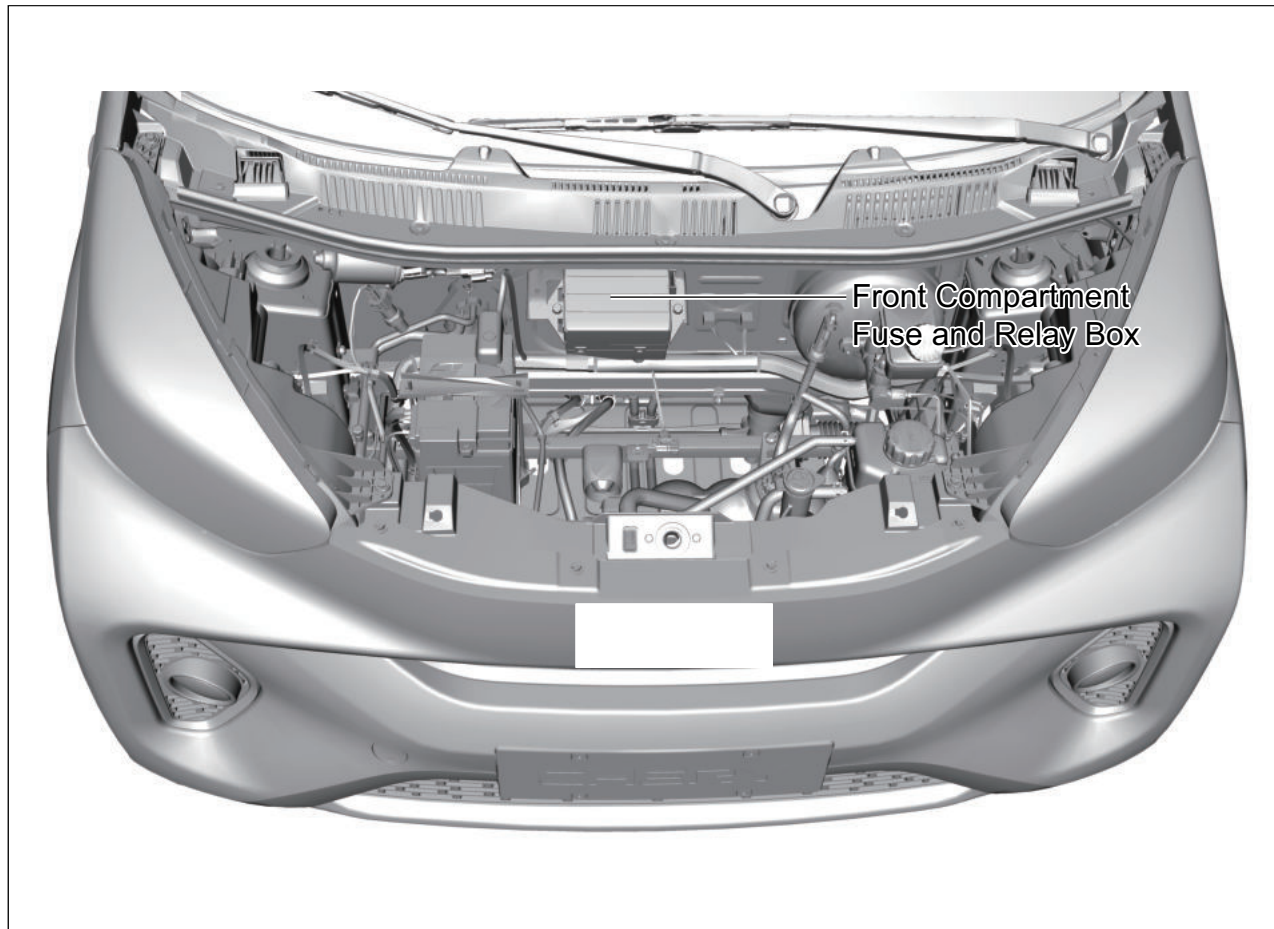

### 2. Front Compartment Fuse and Relay Box Layout

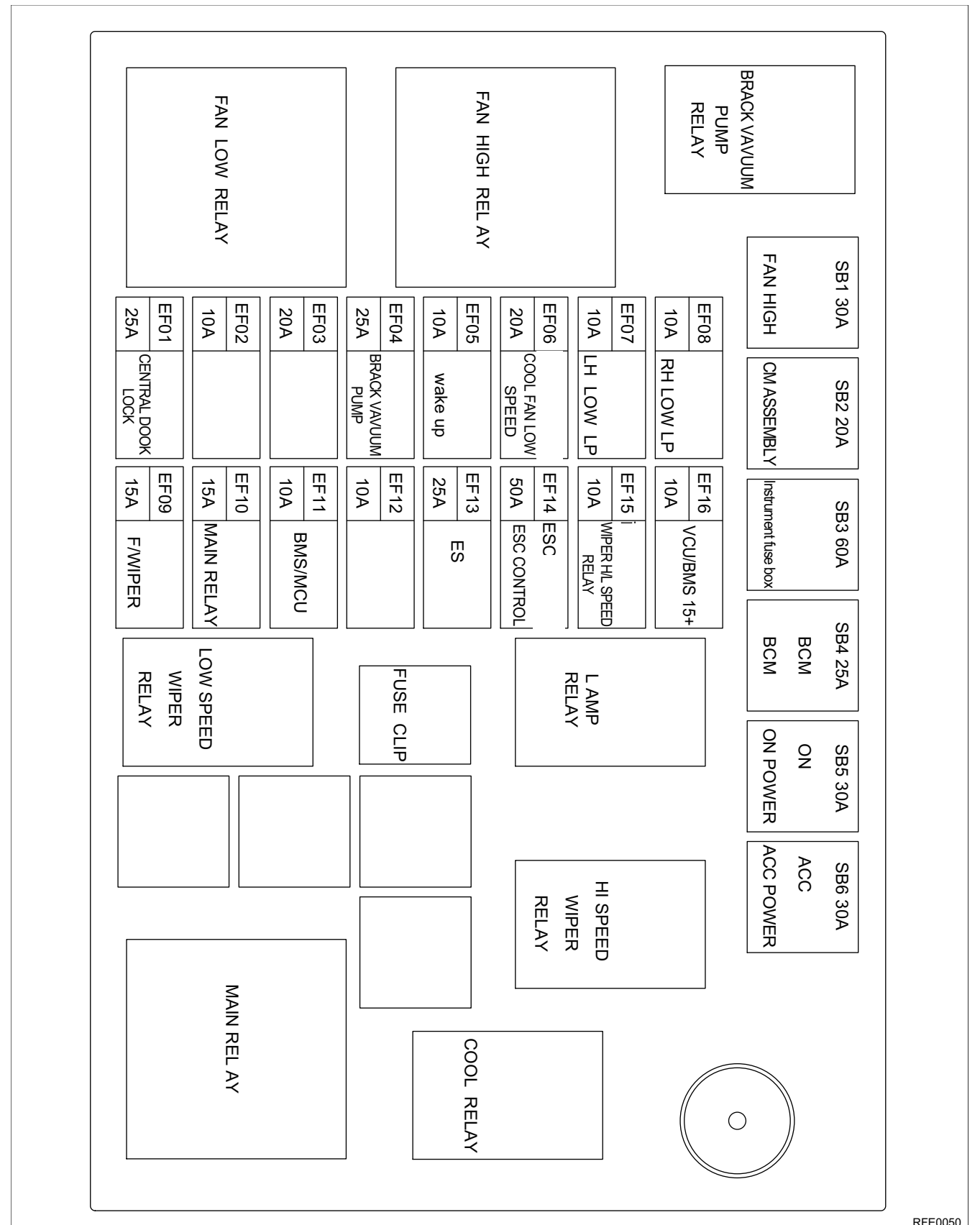

RFE0050



3. Front Compartment Fuse Function Instruction

No.	Fuse Name	Fuse Load (A)	Function
1	SB01	30A	Cooling Fan/VCU
2	SB02	5A	CMDC On-Board Charger
3	SB03	60A	I/P Fuse and Relay Box
4	SB04	25A	BCM
5	SB05	30A	ON Relay
6	SB06	30A	ACC Relay
7	EF01	25A	BCM
8	EF02	-	-
9	EF03	5A	Pedestrian Reminder
10	EF04	25A	BrakeVacuum Pump Relay
11	EF05	10A	Wake Up Relay
12	EF06	20A	Low Speed Fan Relay
13	EF07	10A	Combination Light FL
14	EF08	10A	Combination Light FR
15	EF09	15A	Wiper Low Speed Relay
16	EF10	15A	Main Relay
17	EF11	10A	Combination SNR/Three-In-One Controller/BMS/Tire Pressure Receiver
18	EF12	10A	VCU
19	EF13	25A	ESC Controller
20	EF14	5A	ESC Controller
21	EF15	10A	Wiper Low Speed Relay
22	EF16	10A	A/C High/Low Pressure SW / Front Passenger Power Seat / Shift SW / VCU / Central Gateway (CGW) / PLC Controller

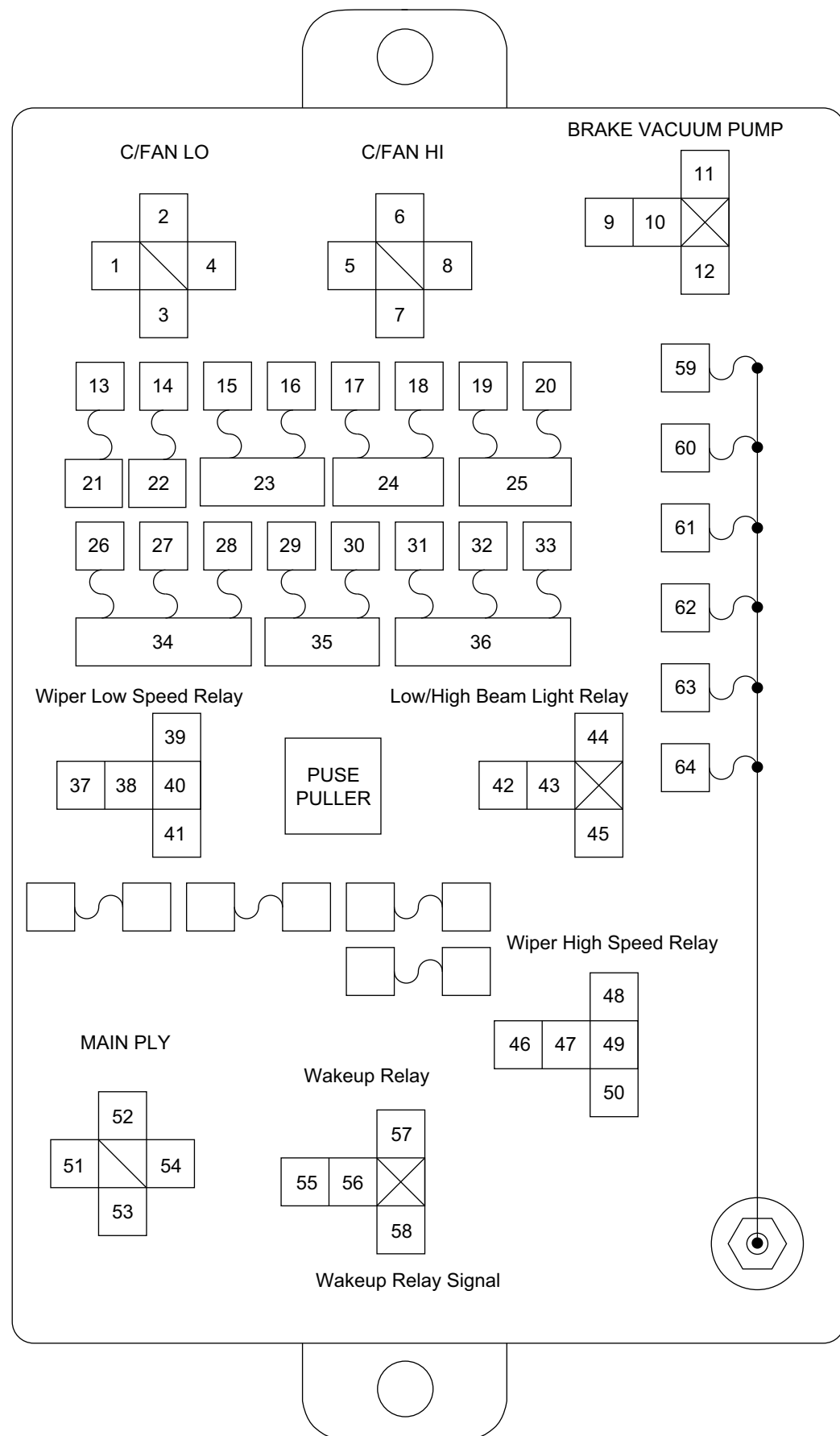

RFE0060

# Fuse and Relay Information

## 4. Front Compartment Fuse and Relay Box Internal Diagram

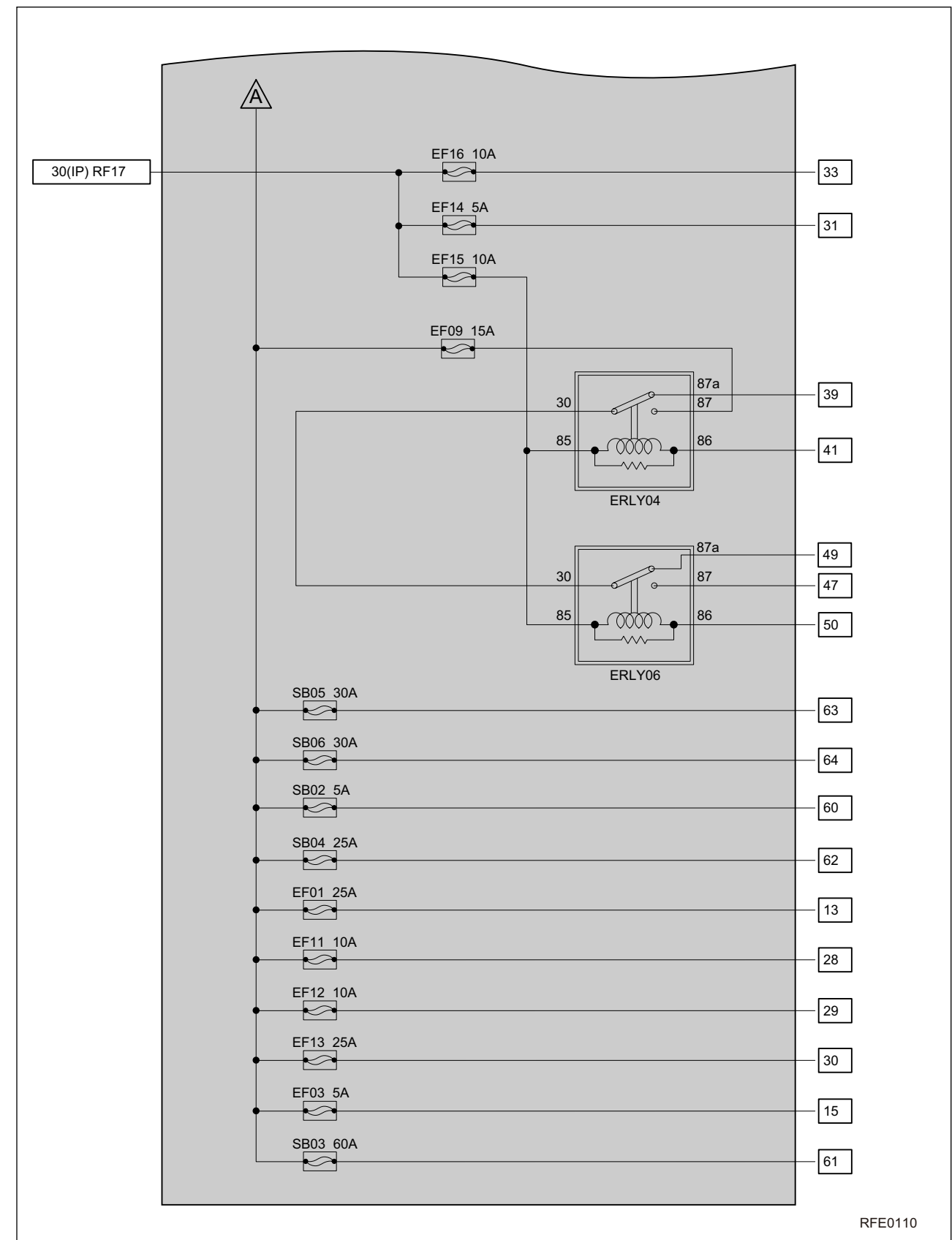
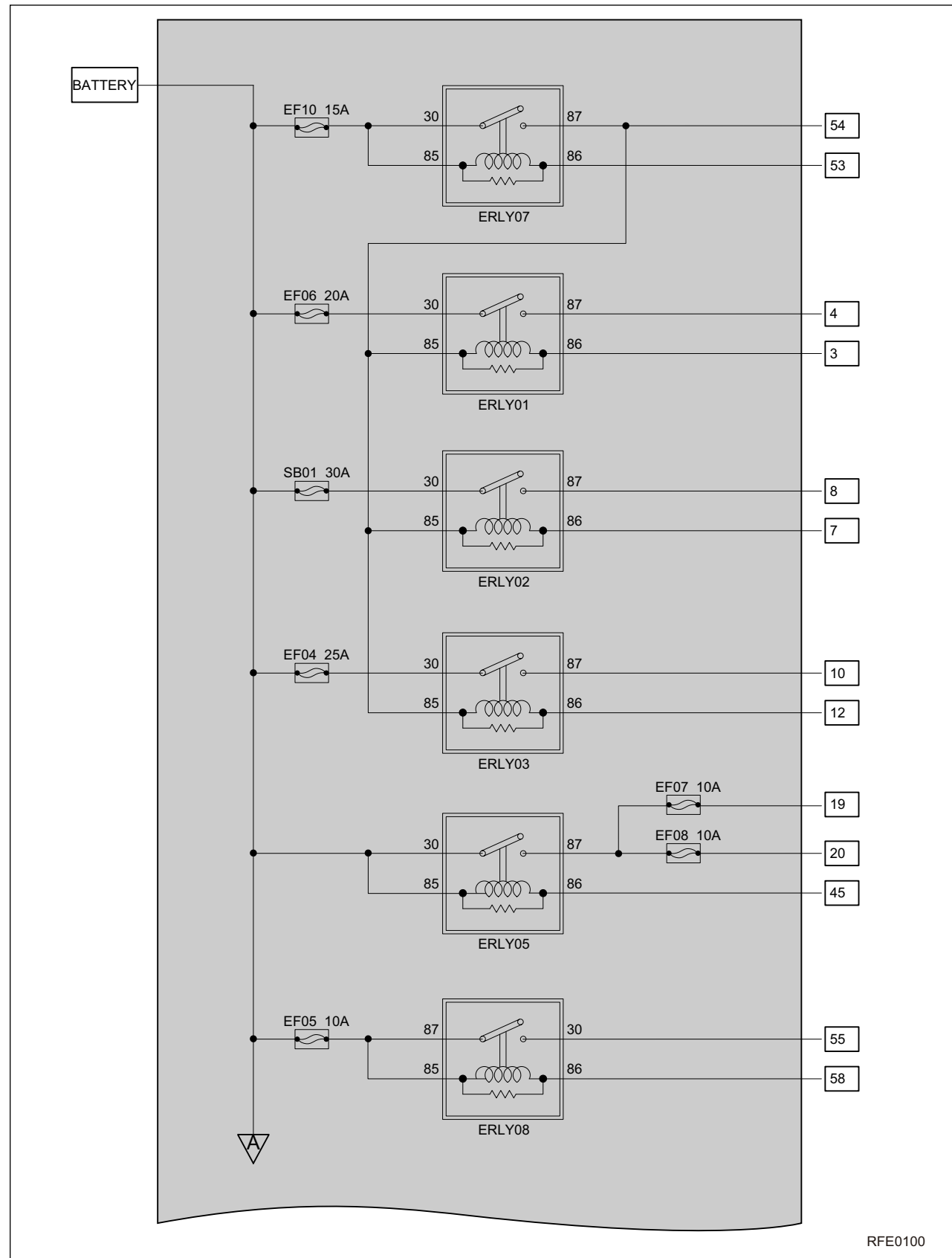

### Meter Fuse and Relay Box

#### 1. Meter Fuse and Relay Box Layout

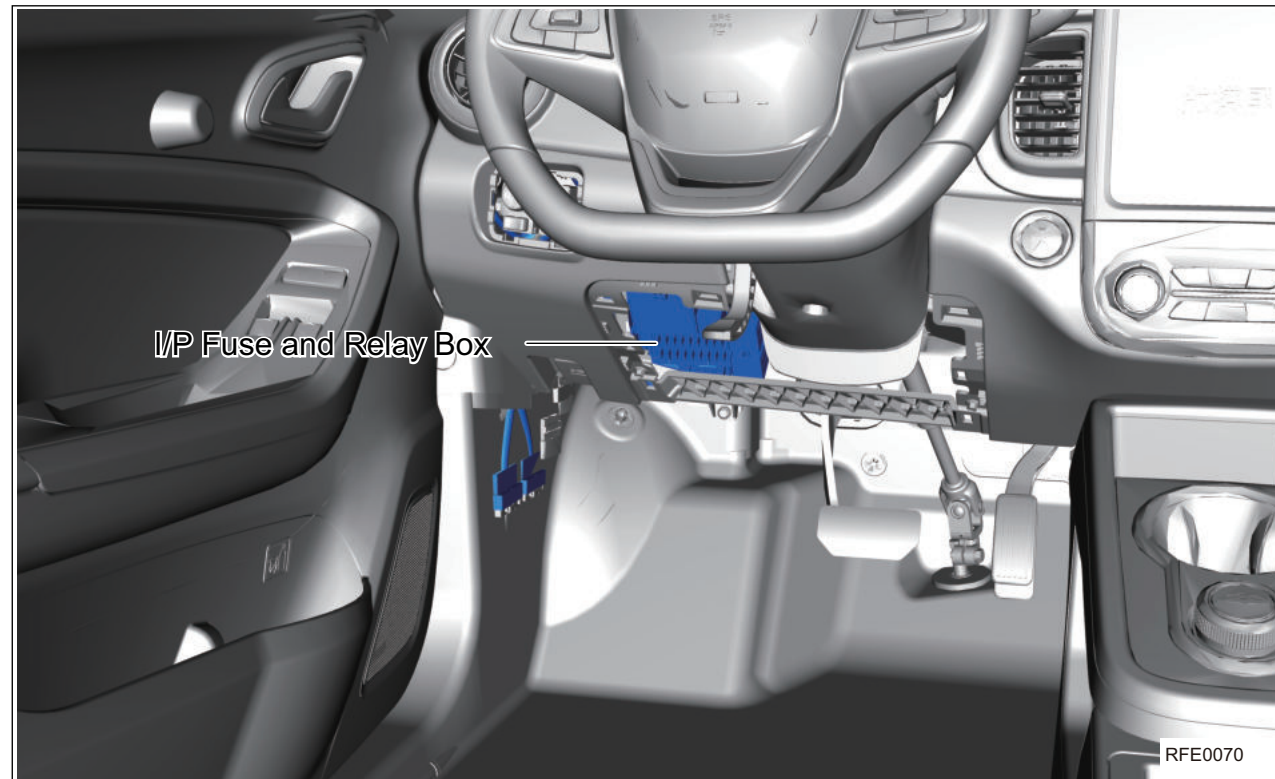

#### 2. I/P Fuse and Relay Box Layout

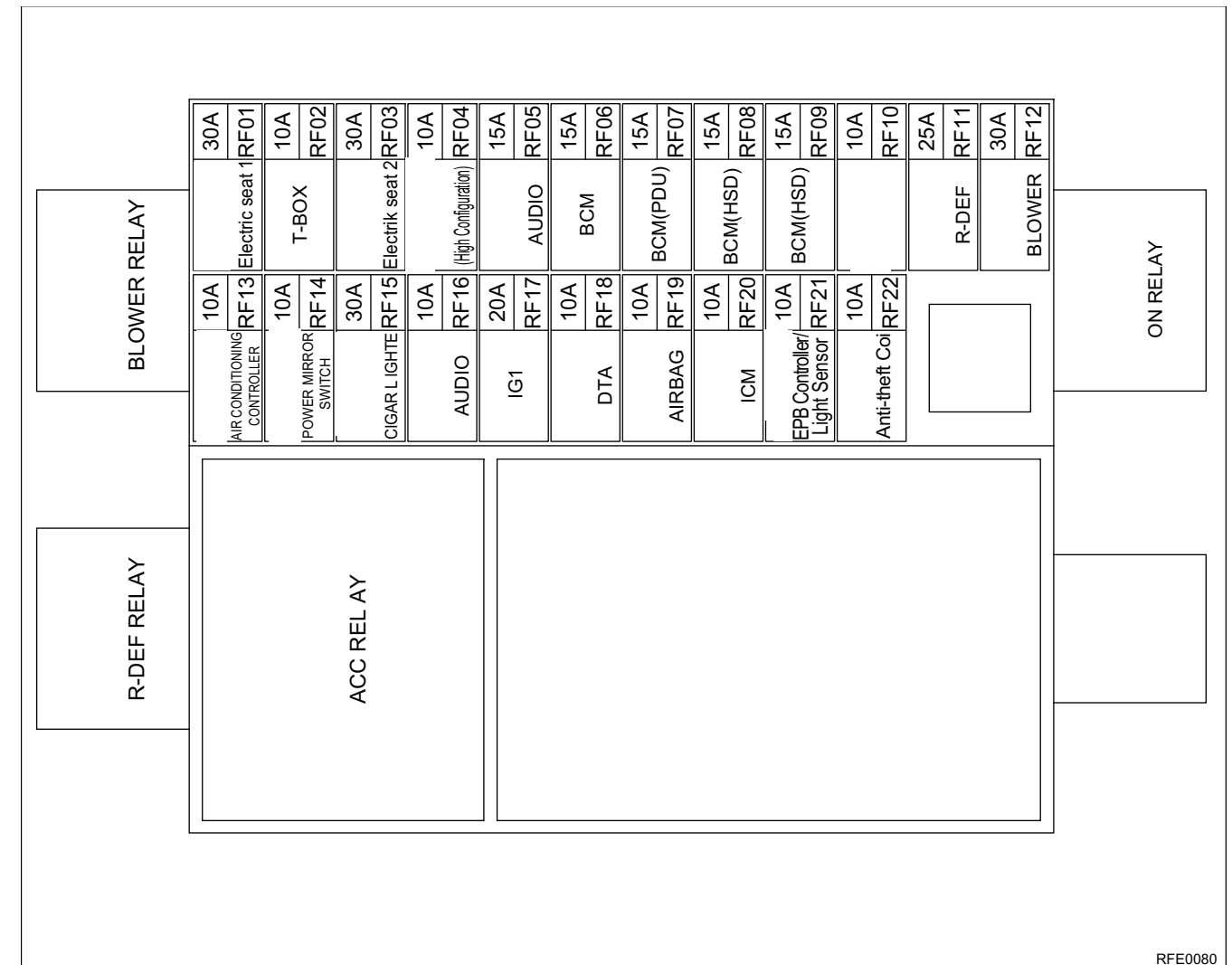

## Fuse and Relay Information

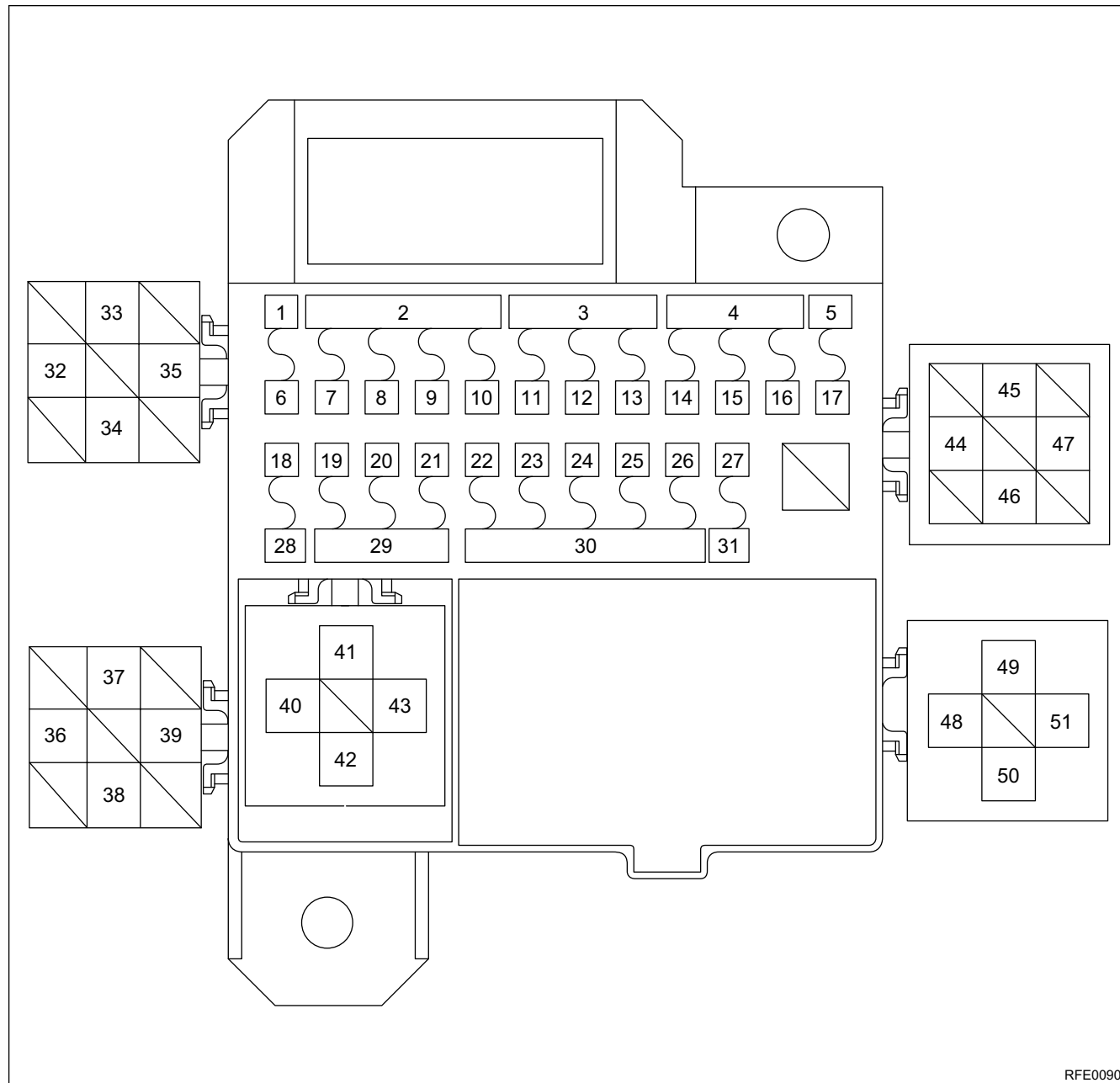

### 3. Meter Fuse Function Description

No.	Fuse Name	Fuse Load (A)	Function
1	RF01	30A	Front Passenger Power Seat/DR Power Seat
2	RF02	10A	Brake SW
3	RF03	30A	Front Passenger Power Seat
4	RF04	10A	Light SNR Central (High Configuration)/ Gateway (CGW)/ Diagnostic Interface/PLC Controller
5	RF05	15A	Start SW/Audio A/Instrument Cluster
6	RF06	15A	BCM
7	RF07	15A	BCM
8	RF08	15A	BCM
9	RF09	15A	BCM
10	RF10	10A	Quick Charging Compatible with 24 V Relay
11	RF11	25A	Rear Defroster Relay
12	RF12	30A	Blower Relay
13	RF13	10A	Rear Defroster Relay/Blower Relay
14	RF14	10A	VCU/Power Rear View Mirror SW
15	RF15	30A	Backup Power
16	RF16	10A	Audio A
17	RF17	20A	Wiper Low Speed Relay/Wiper High Speed Relay
18	RF18	10A	Brake SW/EPS A Signal
19	RF19	10A	Airbag Controller
20	RF20	10A	Instrument Cluster
21	RF21	10A	EPB Controller/Light Sensor
22	RF22	10A	Wireless Charging

4. I/P Fuse and Relay Box Internal Diagram

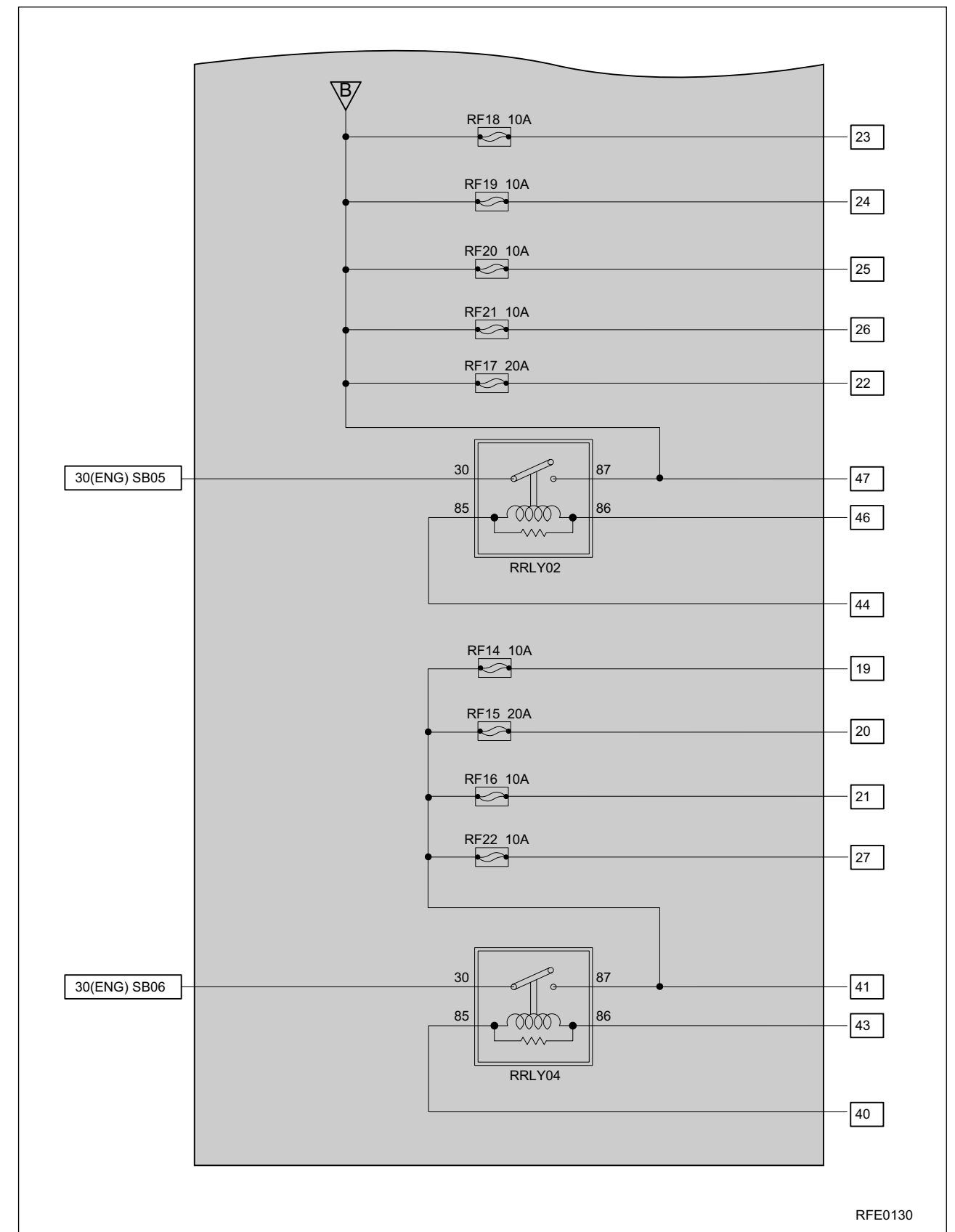
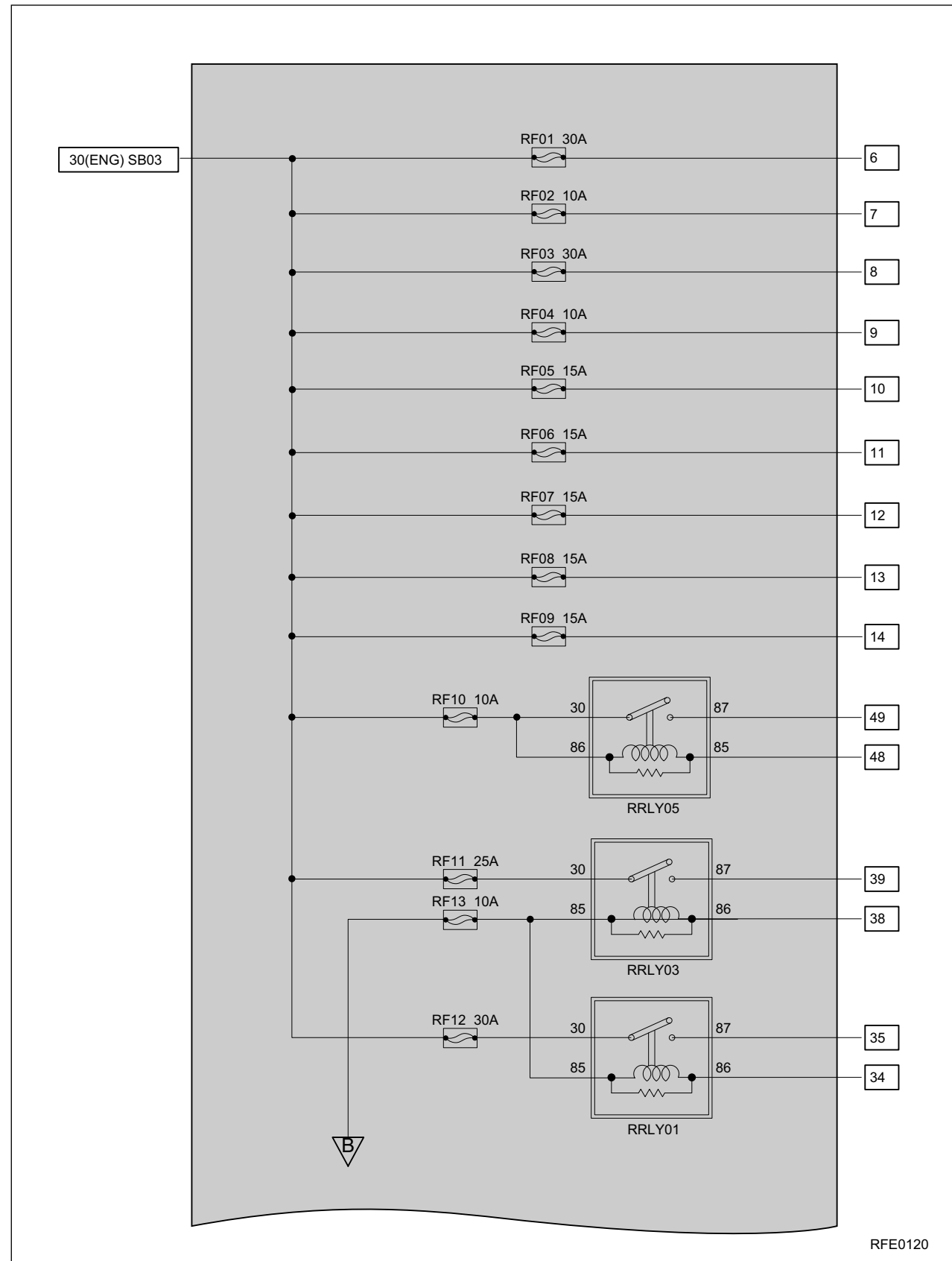

# Power Distribution Center

Compartment Fuse and Relay Box Internal Diagram

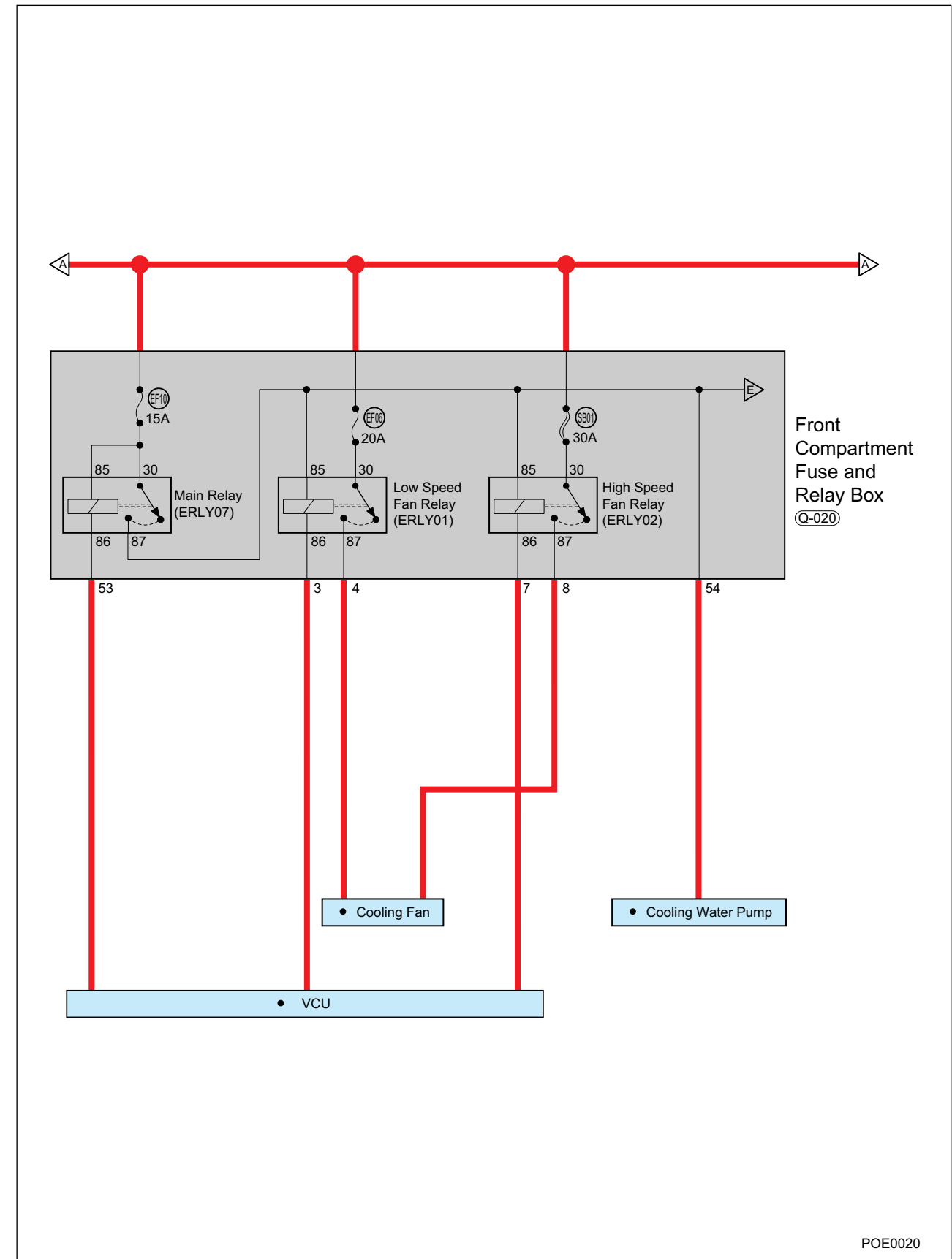
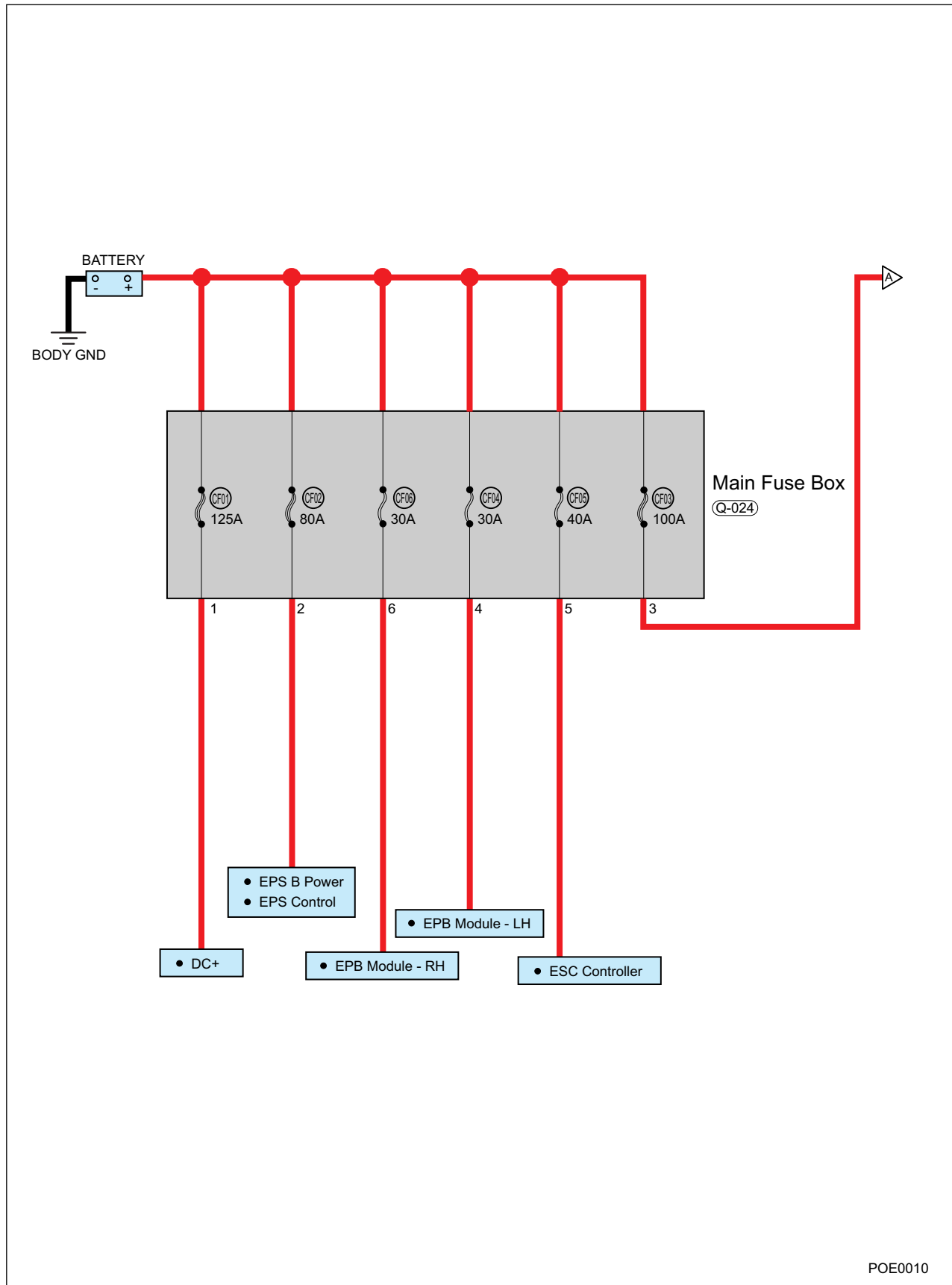



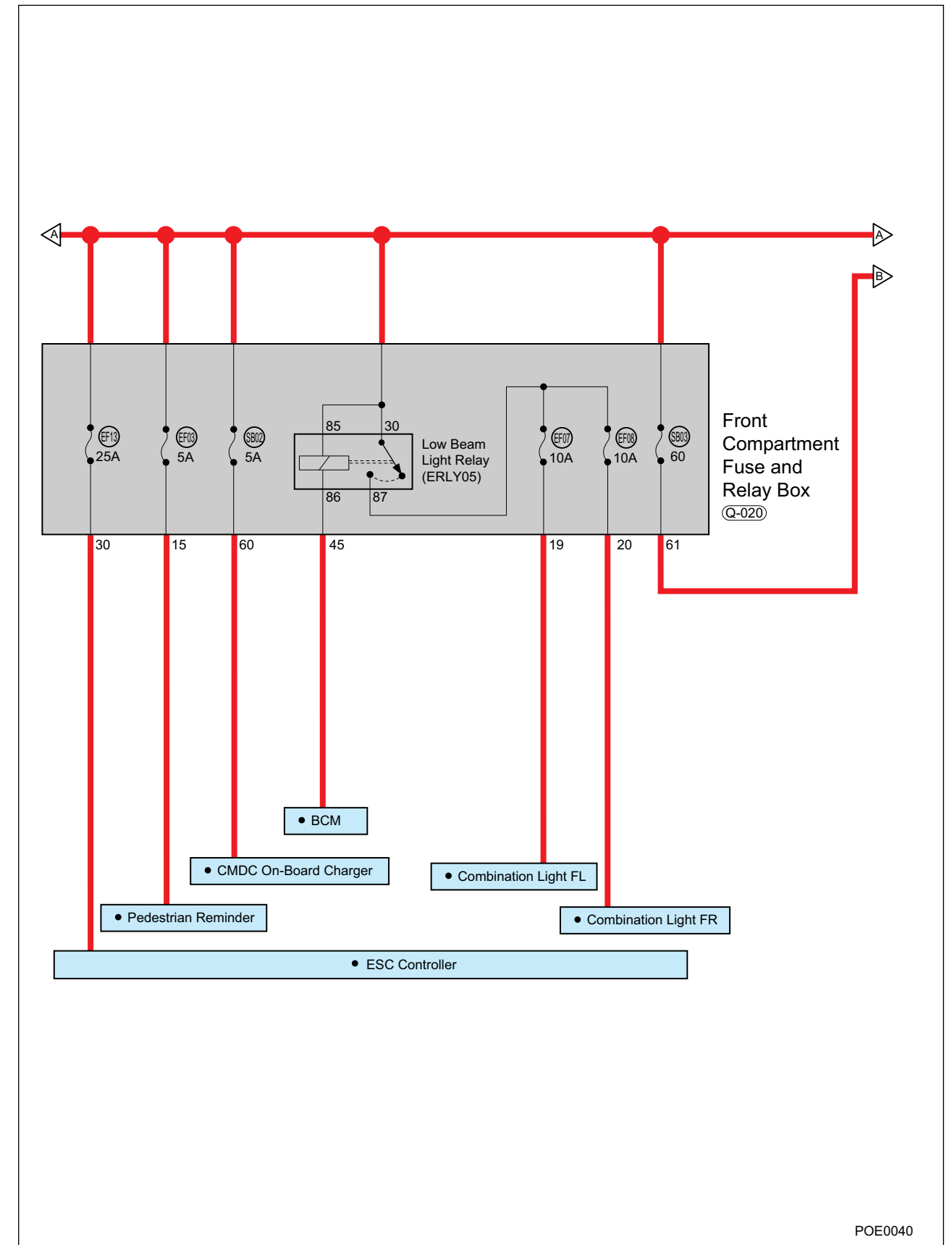
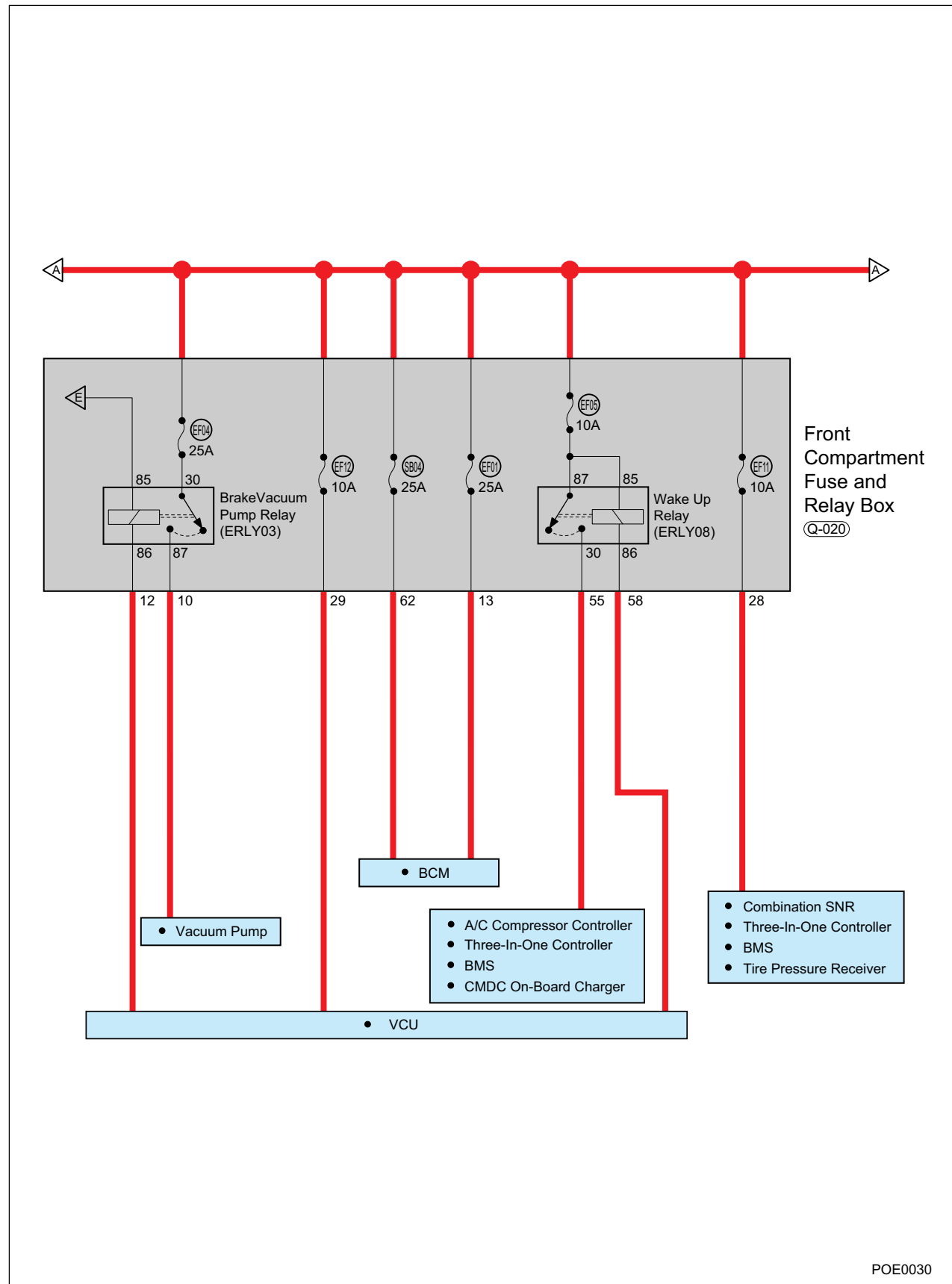

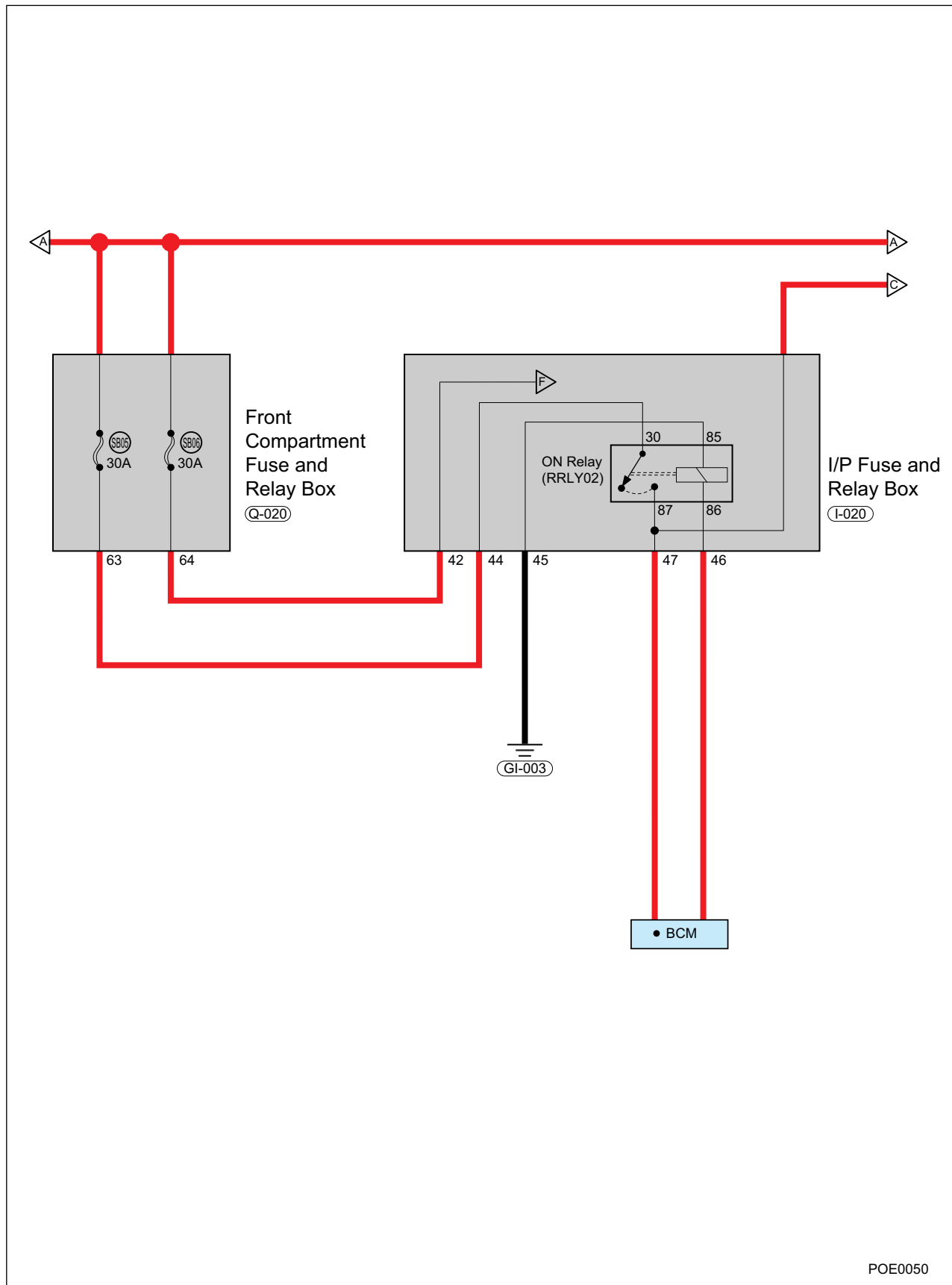

POE0050

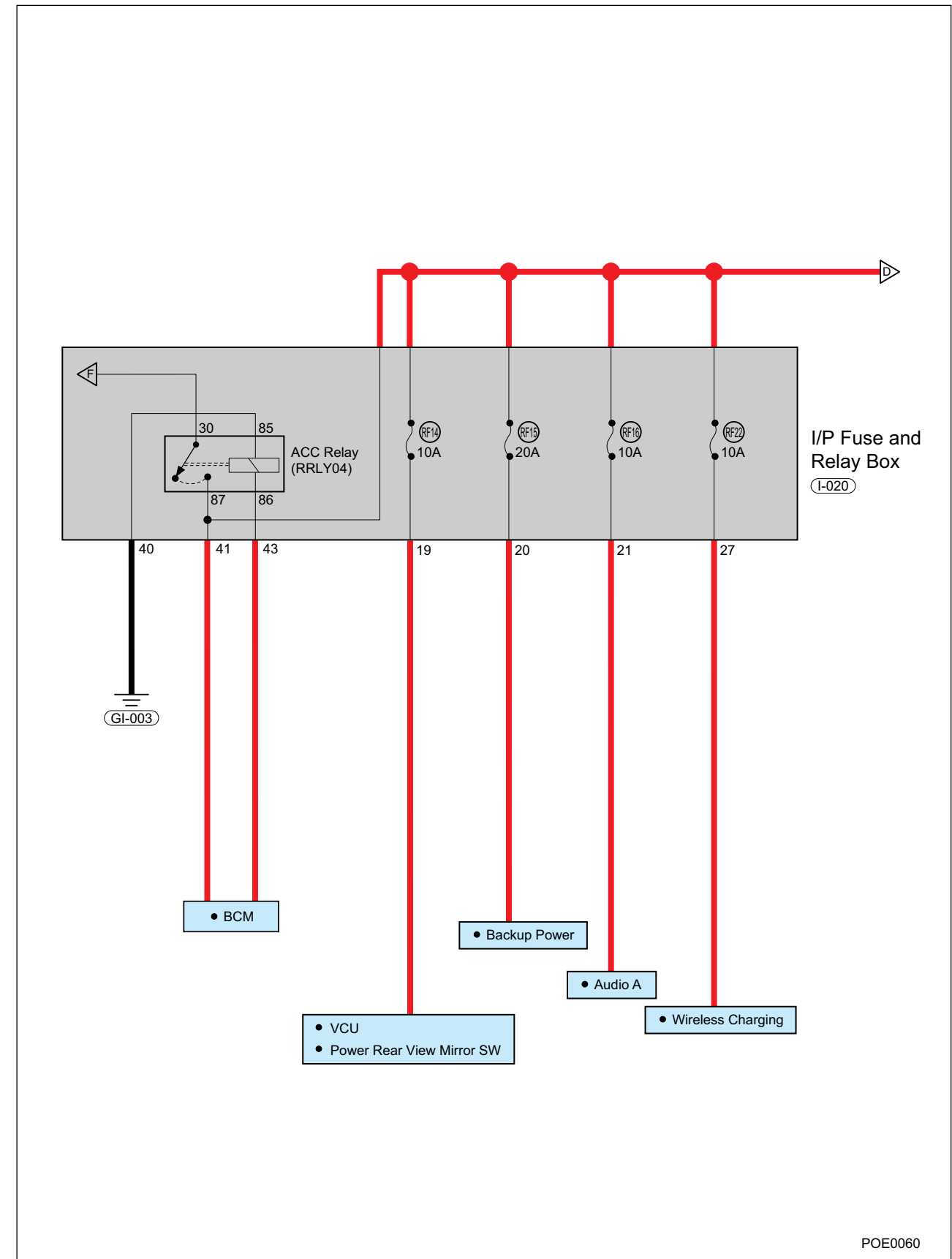

POE0060

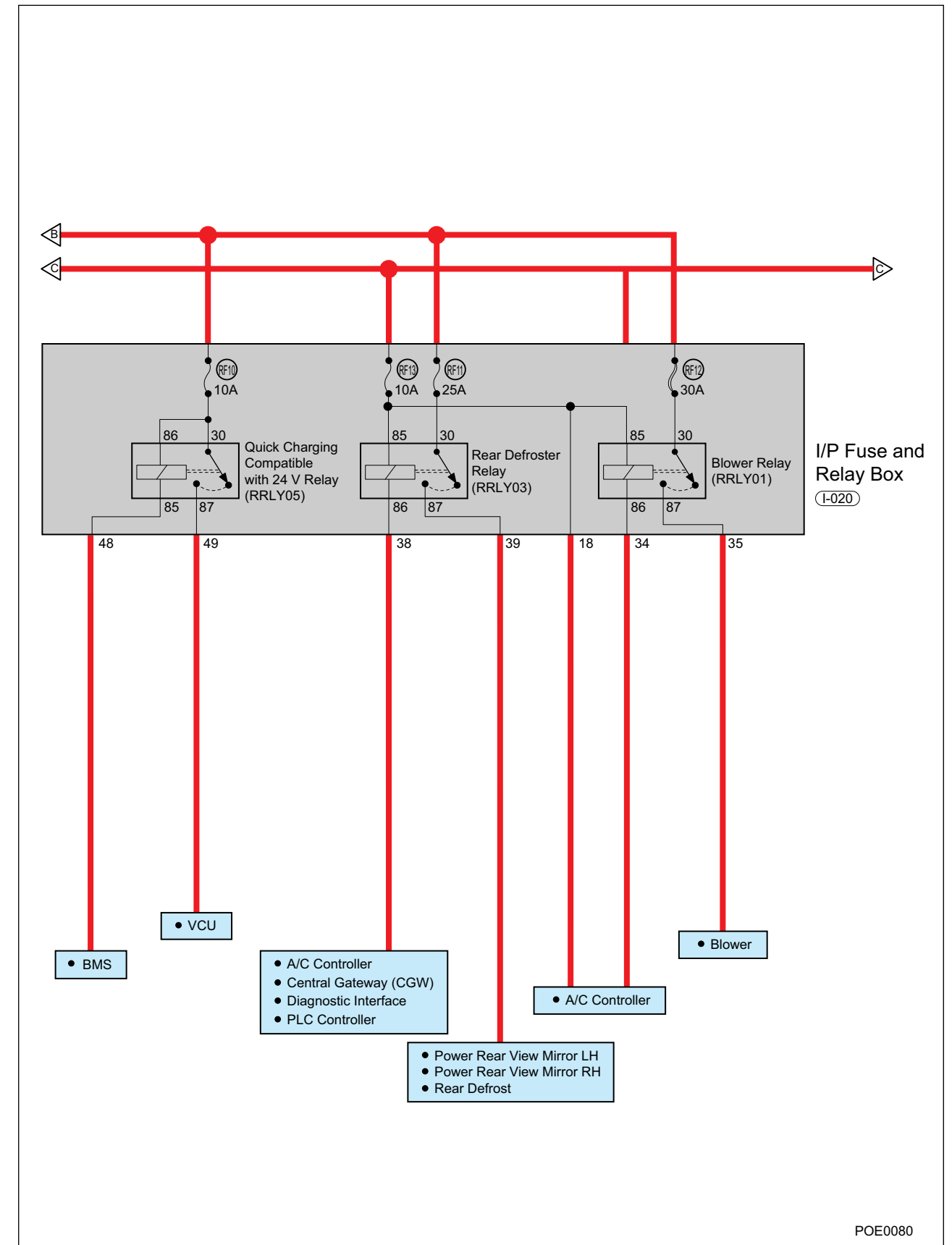
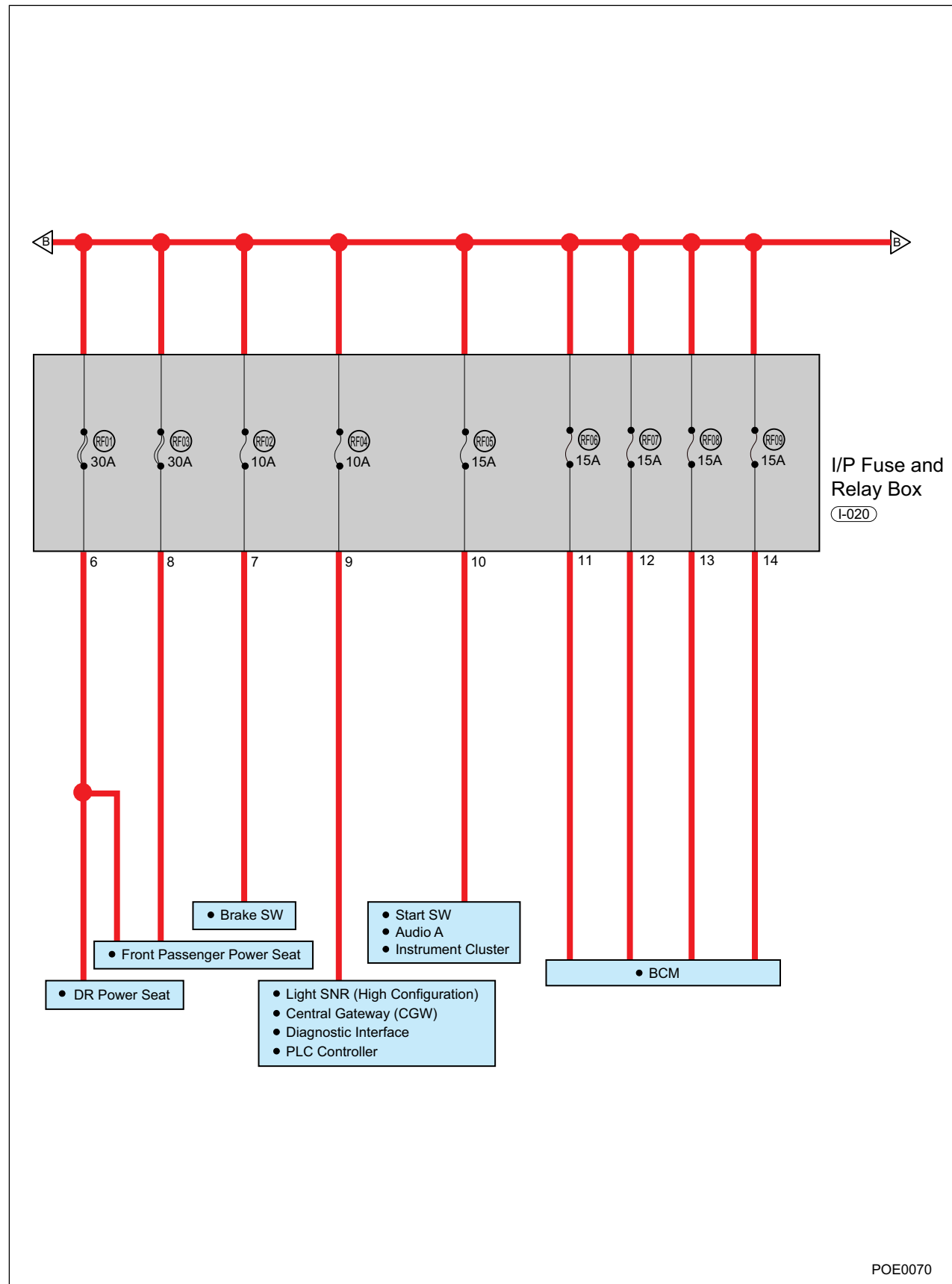

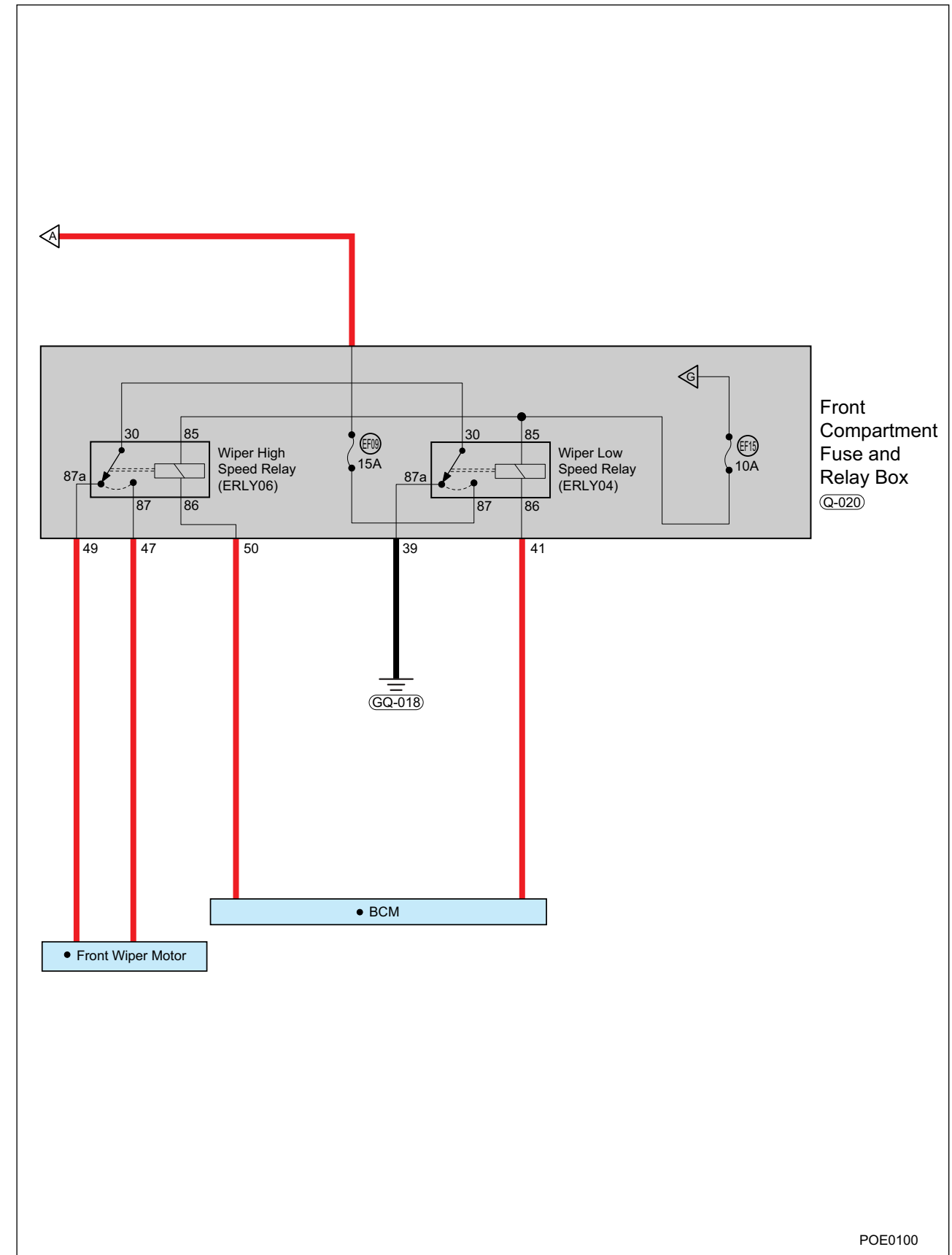
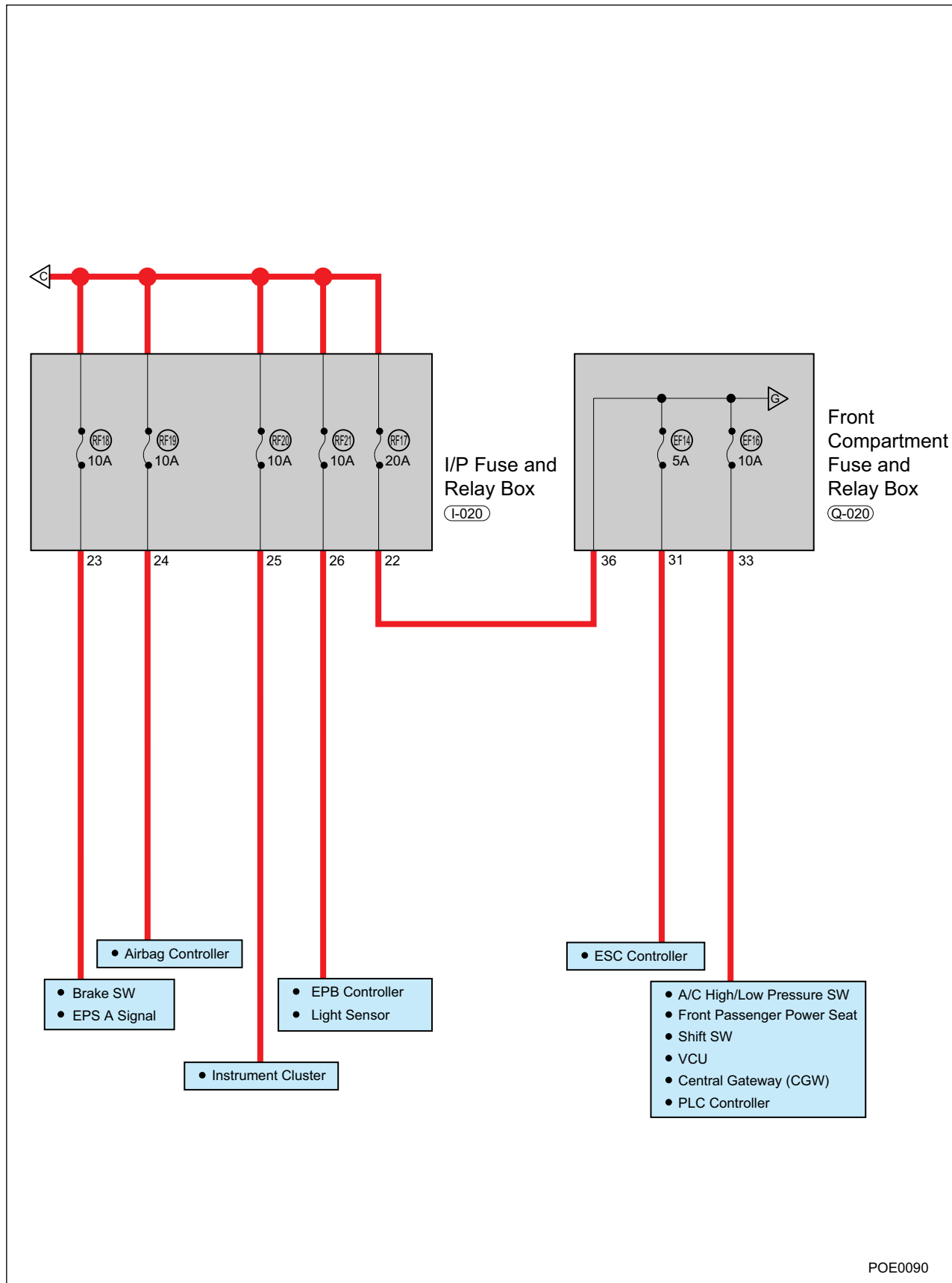

# Control Module Distribution Diagram and Terminal Definition

## Module Terminal Definition

### Vehicle Control Unit (VCU) Module Terminal Definition

#### VCU Module Terminal Definition

PIN	Description	PIN	Description
1	KL30 Power Source Signal	39	High Terminal Drive Backup Port 1
2	KL30 Power Source Signal	40	Digital Input Backup Port 5
3	Power Source Ground Signal	41	Analog Ground
4	Power Source Ground Signal	42	Analog Ground
5	Power Source Ground Signal	43	Analog Ground
6	CAN High	44	ECO Mode SW
7	CAN Low	45	Digital Input Backup Port 6
8	Thermistor Collection 1	46	Analog Backup Port 2
9	Analog Backup Port 1	47	Analog Backup Port 3
10	Analog Backup Port 2	48	Low Terminal Output Backup 6
11	DCDC Load Current	49	Low Terminal Output Backup 7
12	-	50	Digital
13	-	51	Digital
14	Accelerator Pedal Signal 1	52	Square Wave Pulse Output 1
15	Accelerator Pedal Signal 2	53	Square Wave Pulse Output 2
16	DCDC Enable	54	Square Wave Pulse Output 3
17	DCDC Output Voltage Adjustment	55	Digital Input Backup Port 5
18	Ready Signal	56	Digital Input Backup Port 6
19	A/C ON Signal	57	Digital Input Port
20	ACC	58	Digital Input Backup Port 3
21	Ignition SW	59	Digital Input Backup Port 4
22	Analog 5 V Output	60	Charging Connection
23	Analog 5 V Output	61	Square Wave Pulse Input 1
24	Analog 5 V Output	62	Square Wave Pulse Input 2
25	Digital Input Backup Port 1	63	-
26	Digital Input Backup Port 2	64	-
27	Digital Input Backup Port 3	65	Thermistor Collection 2

PIN	Description	PIN	Description
28	Digital Input Backup Port 4	66	Analog Backup Port 3
29	DCDC Self-check Signal	67	Analog Backup Port 4
30	Brake Signal	68	Analog Backup Port 5
31	Low Terminal Drive Backup Port 1	69	Analog Backup Port 6
32	Low Terminal Drive Backup Port 2	70	Analog Backup Port 7
33	Low Terminal Drive Backup Port 3	71	Analog Backup Port 8
34	Low Terminal Drive Backup Port 4	72	-
35	Low Terminal Drive Backup Port 5	73	-
36	Back-up Light Drive Signal	74	Digital Input Backup Port 7
37	Motor Enable Signal	75	Digital Input Backup Port 8
38	Battery Connection Signal		-

### Body Control Module (BCM) Terminal Definition

#### BCM Connector 1 Terminal Definition

PIN	Description	PIN	Description
J1-1	GND	J1-13	RF Antenna
J1-2	Dome Light Output (LSD)	J1-14	Security Indicator Light Output (HSD)
J1-3	IMMO Antenna +	J1-15	Limit Operating Output (Reserved)
J1-4	IMMO Antenna -	J1-16	ACC Input (High Level Trigger)
J1-5	IGN1 Input (High Level Trigger)	J1-17	-
J1-6	KEY Input (Reserved)	J1-18	Remote Lock/Unlock Trigger Signal (Reserved)
J1-7	START Signal	J1-19	Overtaking SW Input (Reserved)
J1-8	Vehicle Speed Signal (Reserved)	J1-20	Position Light SW Input (Low Level Trigger)
J1-9	Front Fog Light Switch (Reserved)	J1-21	Washer SW Input (Low Level Trigger)
J1-10	Wiper Low Speed	J1-22	Low Beam SW Input (Low Level Trigger)
J1-11	Left Turn Light Input (Low Level Trigger)	J1-23	High Beam SW Input (Low Level Trigger)
J1-12	Right Turn Light Input (Low Level Trigger)	J1-24	N (Neutral) Gear Signal (Low Level Trigger)

#### BCM Connector 2 Terminal Definition

PIN	Description	PIN	Description
J2-1	SSB Button SW 1 Input	J2-27	SSB Amber LED Output
J2-2	SSB Ground	J2-28	CAN-H

## Control Module Distribution Diagram and Terminal Definition

PIN	Description	PIN	Description
J2-3	-	J2-29	-
J2-4	-	J2-30	-
J2-5	-	J2-31	-
J2-6	-	J2-32	Washer Output
J2-7	Wiper Low Speed Output	J2-33	-
J2-8	FL Window Up	J2-34	FR Window Up
J2-9	Wiper Intermittent	J2-35	RL Window Up (Reserved)
J2-10	RR Window Up (Reserved)	J2-36	Warning SW
J2-11	Unlock Signal	J2-37	Trunk Touch SW Input
J2-12	Rear Fog Light Switch	J2-38	FL Door Touch SW Input
J2-13	Collision Signal	J2-39	Brake Signal Input
J2-14	SSB Button SW 2 Input	J2-40	SSB Green LED Output
J2-15	SSB Backlight LED Output	J2-41	CAN-L
J2-16	-	J2-42	-
J2-17	-	J2-43	-
J2-18	-	J2-44	-
J2-19	-	J2-45	Wiper High Speed Output
J2-20	-	J2-46	Low Beam Light Output
J2-21	FL Window Down	J2-47	FR Window Down
J2-22	Wiper High Speed	J2-48	RL Window Down (Reserved)
J2-23	RR Window Down (Reserved)	J2-49	RL Door Touch SW Signal (Reserved)
J2-24	Lock Signal	J2-50	RR Door Touch SW Signal (Reserved)
J2-25	FR Door Touch SW Input	J2-51	Horn Input
J2-26	Trunk Open Signal Input	J2-52	Wiper Return

### BCM Connector 3 Terminal Definition

PIN	Description	PIN	Description
J3-1	Power Source	J3-8	FL Window Power Source Up
J3-2	Central Lock Power Source	J3-9	FL Window Power Source Down
J3-3	Front Window Power Source Ground	J3-10	Front Window Power Source
J3-4	Rear Window Power Source Ground (Reserved)	J3-11	FR Window Power Source Up
J3-5	RR Window Power Source Up (Reserved)	J3-12	FR Window Power Source Down

PIN	Description	PIN	Description
J3-6	RR Window Power Source Down (Reserved)	J3-13	RL Window Power Source Up (Reserved)
J3-7	Rear Window Power Source (Reserved)	J3-14	RL Window Power Source Down (Reserved)

### BCM Connector 4 Terminal Definition

PIN	Description	PIN	Description
J4-1	Left Turn Light	J4-7	POWER-HSD
J4-2	Door Locked	J4-8	Battery Save
J4-3	Door Unlocked	J4-9	Anti-theft Horn (Reserved)
J4-4	Back Door Lock Release	J4-10	-
J4-5	Electric Horn	J4-11	Vehicle Lock Ground
J4-6	Right Turn Light	J4-12	Power Source Ground

### BCM Connector 5 Terminal Definition

PIN	Description	PIN	Description
J5-1	POWER-HSD	J5-11	ACC Relay Output
J5-2	Front Fog Light	J5-12	IGN1 Relay Output
J5-3	Rear Fog Light	J5-13	-
J5-4	Front Position Light	J5-14	-
J5-5	Rear Position Light	J5-15	-
J5-6	High Beam Light Output	J5-16	-
J5-7	Backlight Output	J5-17	-
J5-8	Daytime Running Light (Reserved)	J5-18	-
J5-9	Back-up Light (Added)	J5-19	-
J5-10	PDU Power Source	J5-20	-

### BMS Module Terminal Definition

PIN	Description	PIN	Description
A	-	S	Thermistor 1 (New National Standard Reserved to Quick Charge Temperature Sensor)
B	-	T	Thermistor 1 Ground (New National Standard Reserved to Quick Charge Temperature Sensor)
C	DC Charging Pile Charging Guide Circuit CC Signal	U	-



**Control Module Distribution Diagram and Terminal Definition**

PIN	Description	PIN	Description
D	High Pressure Circuit Relay Close Enable Signal	V	-
E	12 V Power Source Voltage for BMS		-
F	Quick Charge Device Ignition Signal	W	Vehicle Ignition Signal
G	BMS Power Source Ground	X	Charger Ignition Signal
H	BMS Power Source Ground	Y	-
J	12 V Power Source Voltage for BMS	Z	Thermistor 2 (New National Standard Reserved to Quick Charge Temperature Sensor)
K	Vehicle CAN High	a	Charging Indicator Drive Signal 1 (Red)
L	Vehicle CAN Low	b	Charging Indicator Drive Signal 2 (Green)
M	Shielded Ground	c	-
N	-	d	DC Charge Wake Up Control
P	Quick Charge CAN Network High	e	Thermistor 2 Ground (New National Standard Reserved to Quick Charge Temperature Sensor)
R	Quick Charge CAN Network Low		

**ESC Module Terminal Definition**

PIN	Description	PIN	Description
1	ESC Motor	20	-
2	-	21	-
3	-	22	-
4	Wheel Speed SNR Signa FR	23	-
5	-	24	-
6	-	25	ESC Valve
7	IGN	26	CAN-0H
8	Wheel Speed SNR Signal FL	27	CAN-2H
9	Auto Hold Switch	28	-
10	-	29	Wheel Speed SNR Signal RR
11	-	30	Brake Switch Signal
12	Auto Hold Switch Indicator	31	"Wheel Speed SNR Power Source RL"
13	Ground	32	-
14	CAN-0L	33	-
15	CAN-2L	34	-
16	Wheel Speed SNR Power Source FL	35	-

PIN	Description	PIN	Description
17	Wheel Speed SNR Power Source RR	36	-
18	Wheel Speed SNR Signal RL	37	-
19	Wheel Speed SNR Power Source FL	38	Ground

**EPB Module Terminal Definition**

**EPB Module - LH**

PIN	Description	PIN	Description
1	Left Motor Power Supply Ground	7	Left Motor Power Supply
2	CAN-2H	8	CAN-2L
3	EPB Switch Signal 2	9	EPB Switch Signal 3
4	-	10	Left Ignition Signal
5	-	11	-
6	Left Motor Negative	12	Left Motor Positive

**EPB Module - RH**

PIN	Description	PIN	Description
1	Right Motor Power Supply	7	Right Motor Power Supply Ground
2	CAN-2L	8	CAN-2H
3	EPB Switch Signal 1	9	EPB Switch Signal 4
4	Right Ignition Signal	10	EPB Switch Indicator
5	-	11	-
6	Right Motor Positive	12	Right Motor Negative

**EPS Module Terminal Definition**

PIN	Description	PIN	Description
A1	IGN	A6	-
A2	-	A7	CAN-2H
A3	-	A8	CAN-2L
A4	-	B1	Power Source
A5	-	B2	Ground

**EPS Control Terminal Definition**

PIN	Description	PIN	Description
1	-	5	Speed Output
2	K Line	6	IGN

## Control Module Distribution Diagram and Terminal Definition

PIN	Description	PIN	Description
3	EPS Malfunction Light	7	Power Source
4	-	8	Ground

### Instrument Cluster Module Terminal Definition

PIN	Description	PIN	Description
1	Door Open	17	Airbag
2	Speed Output (Low Level)	18	Parking Brake
3	Ground	19	Seat Belt
4	EPS	20	-
5	Reverse Radar Data Signal LIN	21	-
6	Front Fog Light (Reserved)	22	Left Turn Signal Indicator
7	Speed Frequency Signal Output	23	Steering Wheel Button Input (A total of 3 buttons including Left, Right and Set) - High Configuration Table
8	Speed Output (Pedestrian Reminder Received)	24	Right Turn Signal Indicator
9	-	25	High Beam Indicator
10	-	26	Brake Fluid Level Low
11	Battery (KL30)	27	-
12	Clock (Reverse Radar Clock Signal Wire)	28	Position Light Indicator
13	Constant Power Source	29	CAN-L
14	-	30	CAN-H
15	-	31	Daytime Running Light Indicator (Reserved)
16	-	32	Rear Fog Light

### Cooling system Module Terminal Definition

PIN	Description	PIN	Description
1	Expansion Tank Cap	10	Water Pump Outlet Pipe
2	Expansion Tank	11	Front Compartment Cooling Pipe I
3	Expansion Tank Bracket	12	Front Compartment Cooling Pipe II
4	Radiator Discharge Hose	13	Floor Cooling Pipe I
5	Radiator Assembly	14	Floor Cooling Pipe II
6	Cooling Fan Assembly	15	Motor Water Outlet Pipe
7	Radiator Water Inlet Pipe	16	Motor Water Inlet Pipe

PIN	Description	PIN	Description
8	Water Pump Inlet Pipe Assembly	17	Rear Compartment Cooling Pipe Assembly
9	Electric Water Pump Assembly	18	Motor Controller Water Inlet Pipe

### Audio Head Unit Terminal Definition

PIN	Description	PIN	Description
A-1	Power Supply for Camera (Output 12V of power supply voltage)	C-3	Camera Video Ground
A-2	12 V Power Source Voltage for ANT Radio Antenna	C-4	-
A-3	VGND (Camera Video Ground)	C-5	-
A-4	ACC SW	C-6	-
A-5	GND Ground	C-7	-
A-6	ILL	C-8	Steering Wheel Button Control Ground Wire
A-7	Battery Power Source Input	C-9	-
A-8	Power Source Ground	C-10	Steering Wheel Button Control Wire 1
B-1	RR Horn Output +	C-11	Steering Wheel Button Control Wire 2
B-2	RR Horn Output -	C-12	-
B-3	FR Horn Output +	C-13	-
B-4	FR Horn Output -	C-14	CAN_H
B-5	FL Horn Output +	C-15	Reverse Gear Control Signal
B-6	FL Horn Output -	C-16	Vehicle Speed Signal Output
B-7	RL Horn Output +	C-17	CAN(GND)
B-8	RL Horn Output -	C-18	-
C-1	Rear Camera Video Output	C-19	-
C-2	-	C-20	CAN_L

### Airbag Module Terminal Definition

PIN	Description	PIN	Description
1	-	26	-
2	-	27	-
3	-	28	-
4	-	29	-
5	Power Source (Input)	30	-
6	Ground Terminal (Input)	31	-

PIN	Description	PIN	Description
7	Airbag Warning Light (Output)	32	-
8	-	33	-
9	Communication Wire K-LINE	34	Collision Output
10	Driver Airbag Drive Low Terminal	35	-
11	Driver Airbag Drive High Terminal	36	-
12	-	37	-
13	Front Passenger Airbag Drive High Terminal	38	-
14	Front Passenger Airbag Drive Low Terminal	39	-
15	CAN-H	40	CAN-L
16	-	41	-
17	-	42	-
18	-	43	-
19	-	44	-
20	-	45	-
21	-	46	-
22	-	47	-
23	-	48	-
24	-	49	-
25	-	50	Collision Output

**Reverse Radar Module Terminal Definition**

PIN	Description	PIN	Description
1	R-Shift (Reverse Signal, Module Power Source)	9	-
2	-	10	-
3	-	11	-
4	-	12	-
5	-	13	Data Wire
6	-	14	-
7	Left Probe Signal	15	Right Probe Signal
8	-	16	Ground

**On-board Charger DCDC Converter Assembly**

**Connector 1**

PIN	Description	PIN	Description
1	DC+	3	Interlock
2	DC-	4	Interlock

**Connector 2**

PIN	Description	PIN	Description
1A	-	3A	CP
1B	-	3B	CC
1C	Inverter_trigger_in	3C	-
1D	-	3D	KL15
1E	-	3E	-
1F	-	3F	-
1G	-	3G	-
1H	KL30	3H	Elock+
2A	Hw_wakeup_output	4A	CAN_1H
2B	NTC+	4B	CAN_1L
2C	-	4C	HVIL_in
2D	NTC_GND	4D	HVIL_out
2E	-	4E	-
2F	-	4F	Elock_sense
2G	-	4G	KL31
2H	-	4H	Elock-

**Connector 3**

PIN	Description	PIN	Description
1	L	4	Interlock
2	N	5	Interlock
3	PE		

# Ground Point Ground Points Layout

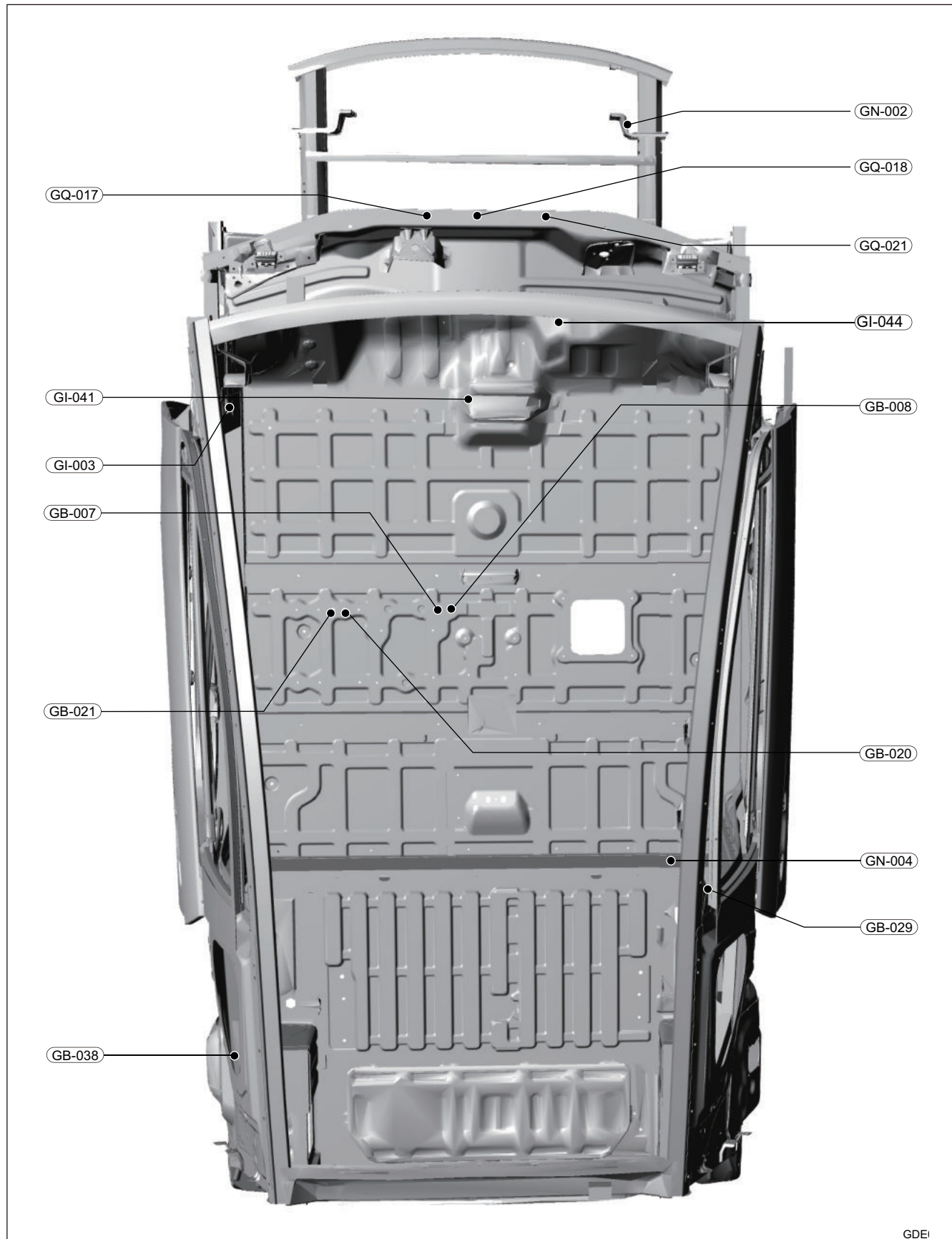

GDEI

# Ground Point Definition

Interior Wire Harness Ground Point GB-007/GB-008/GB-020 Ground Wiring Diagram

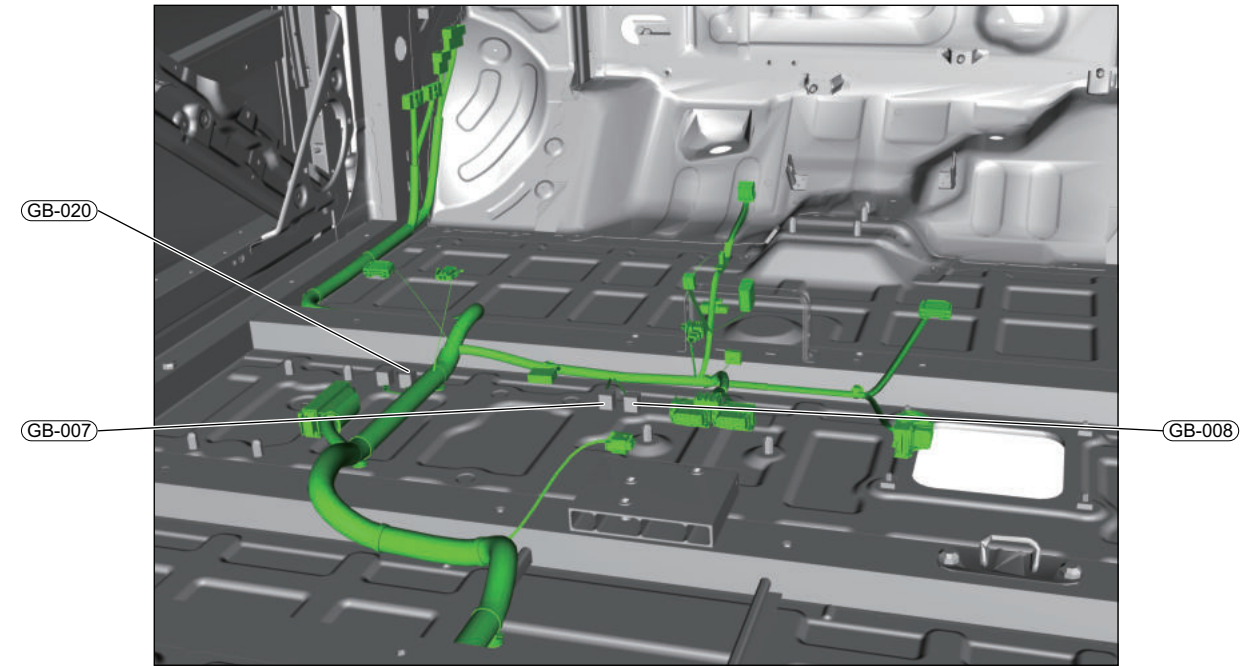

EPB Module - LH  
(B-016)

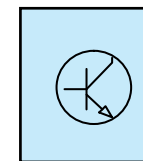

2.5 B



GB-007

EPB Module - RH  
(B-017)

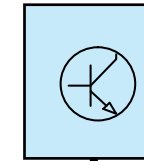

2.5 B



GB-008

VCU  
(B-022)

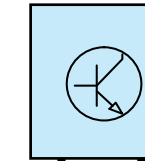

0.75 B



GB-020

GDE0020



Interior Wire Harness Ground Point GB-021 Ground Wiring Diagram

Interior Wire Harness Ground Point GB-021 Ground Wiring Diagram

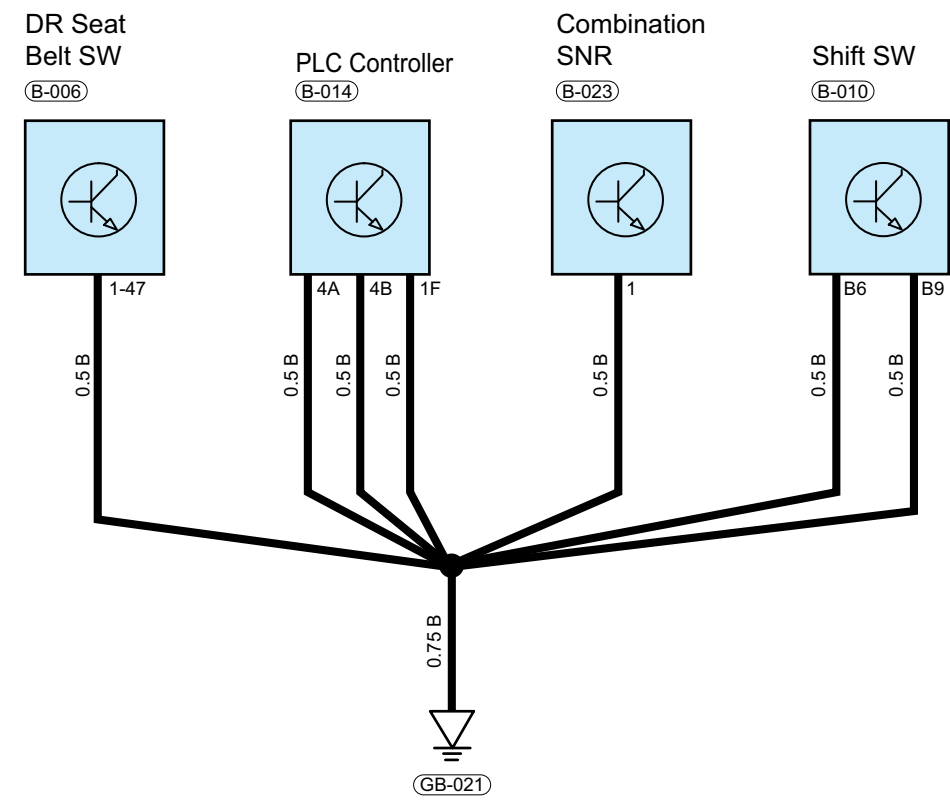
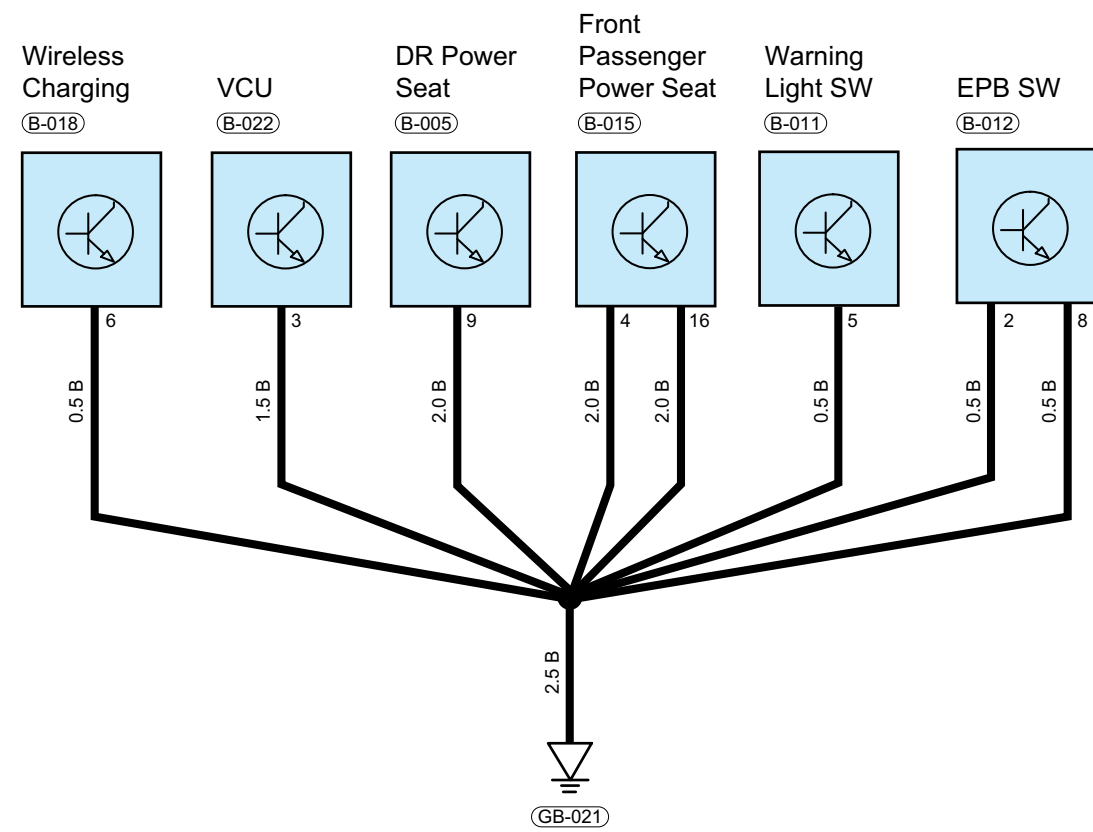
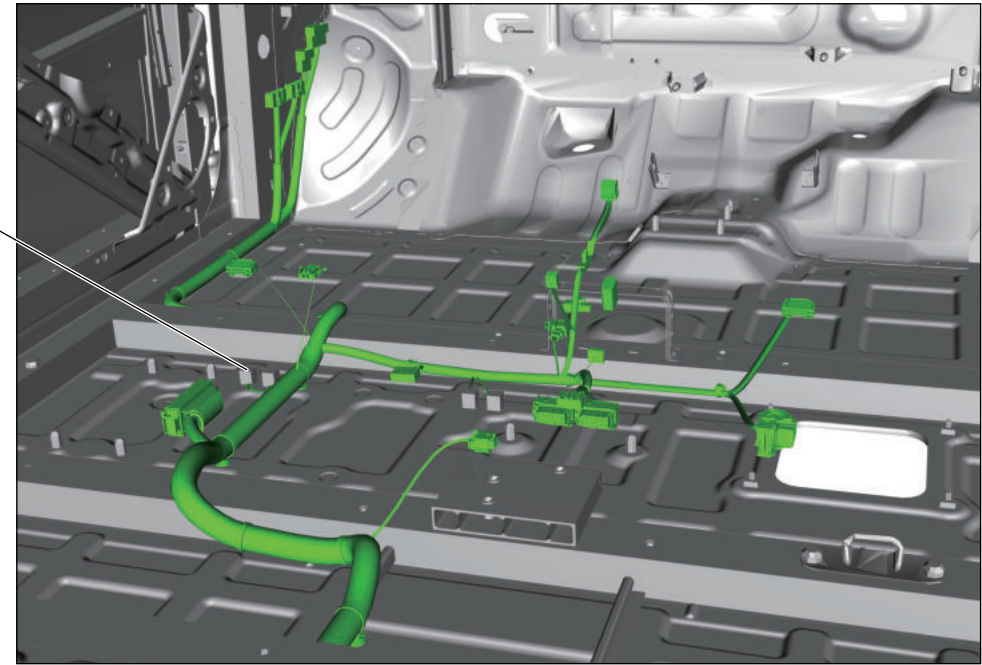
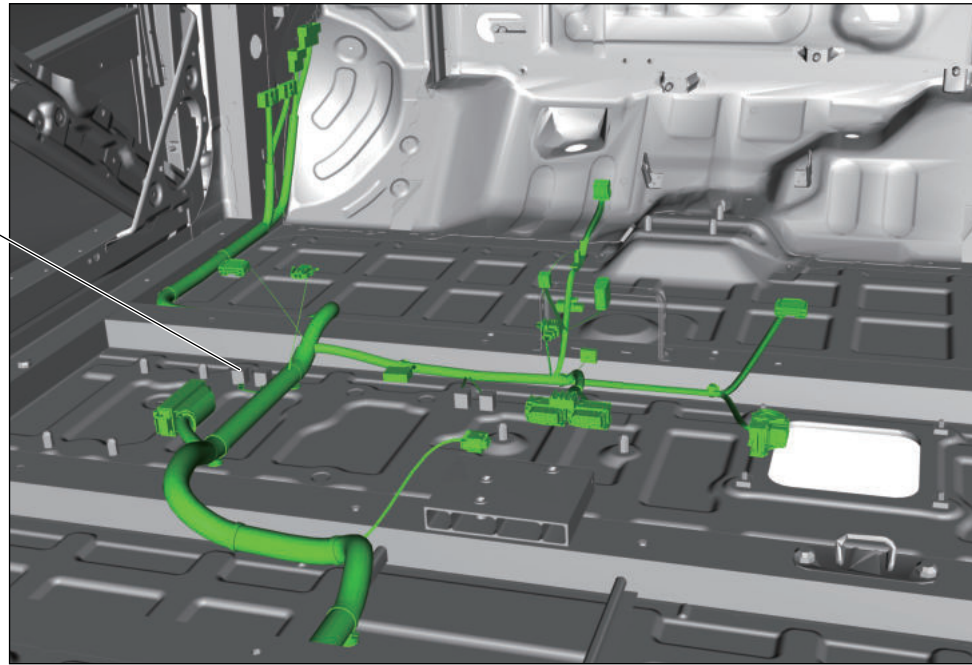

GDE0030

GDE0040

# Ground Point

## Interior Wire Harness Ground Point GB-038 Ground Wiring Diagram

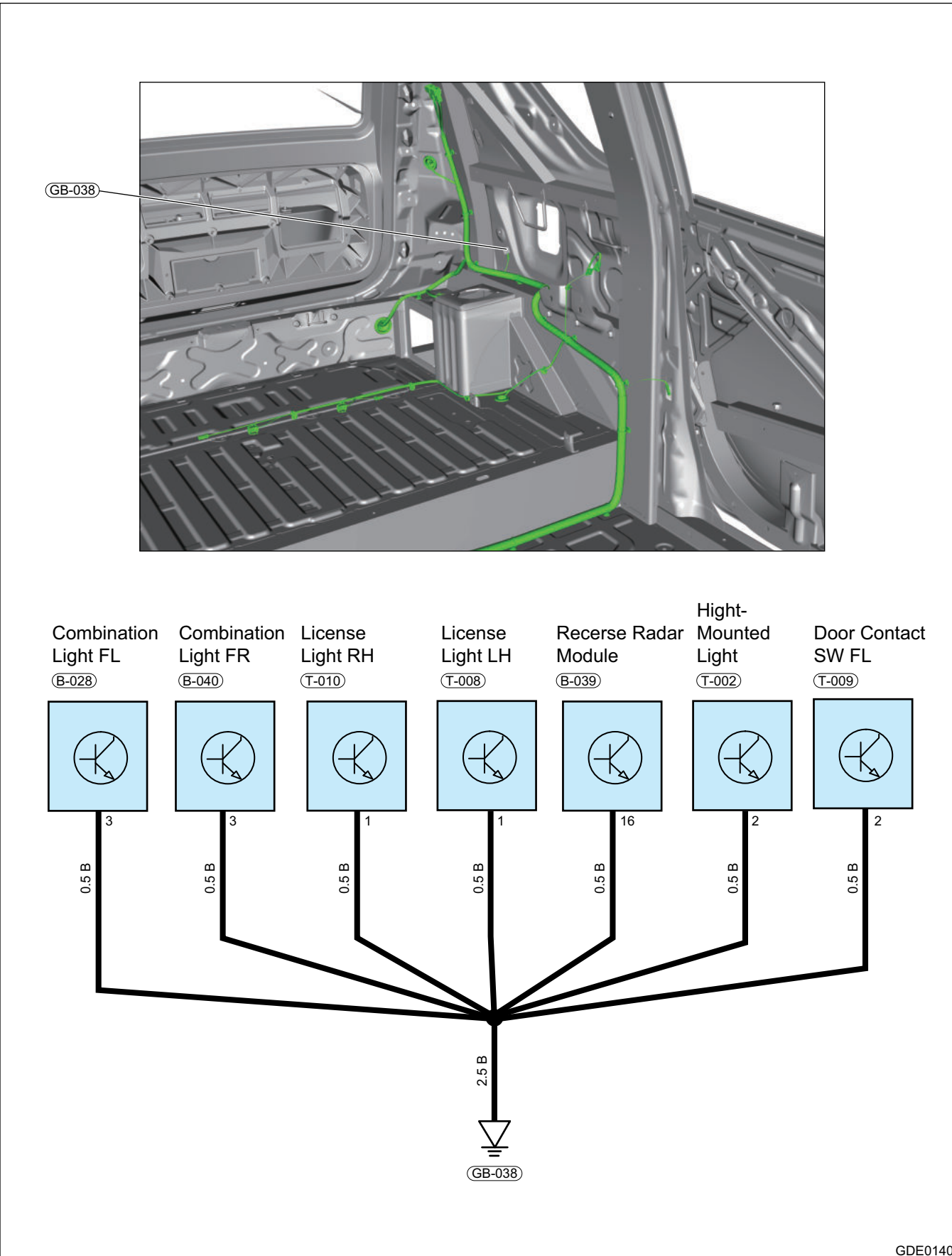

## Interior Wire Harness Ground Point GB-038 Ground Wiring Diagram

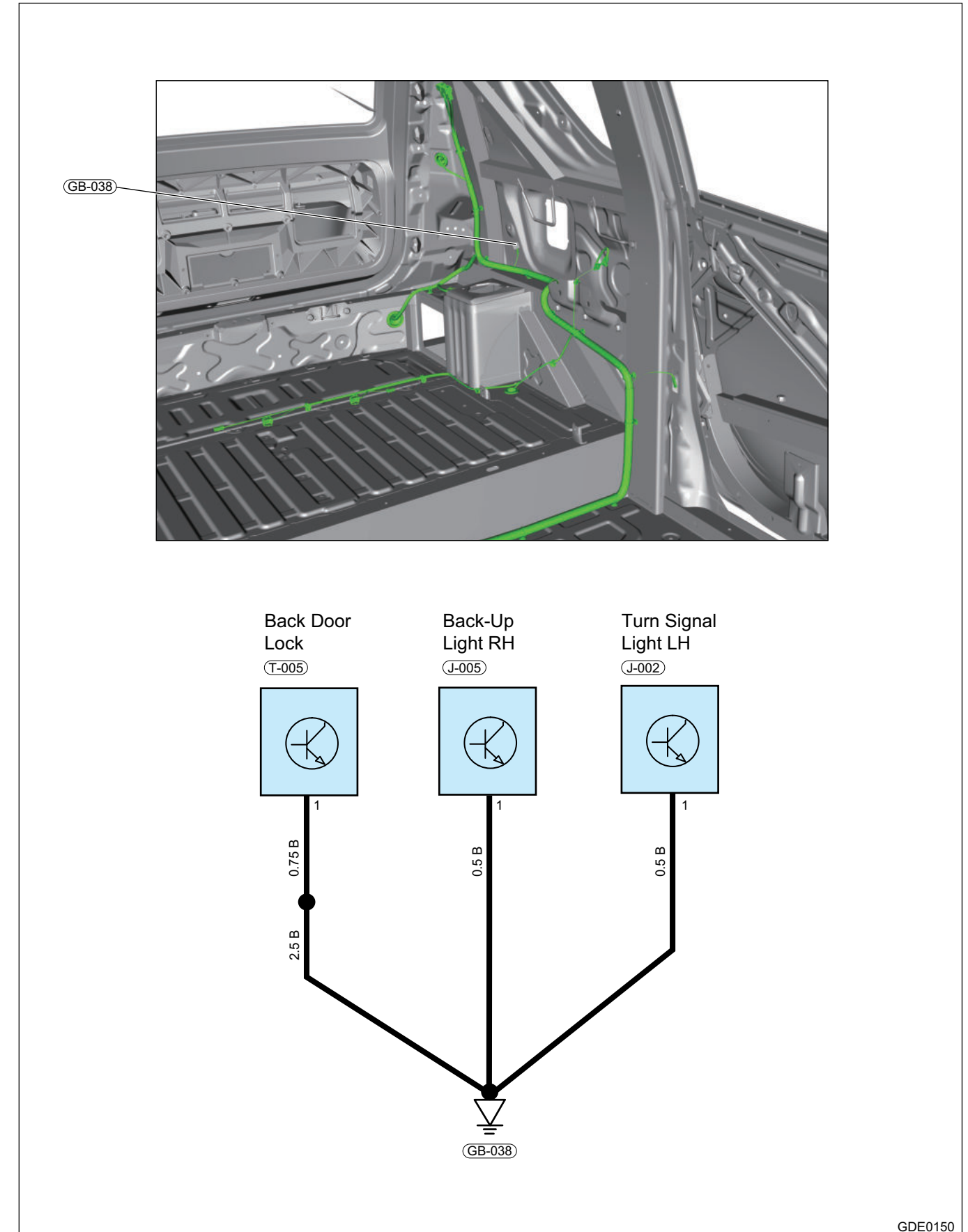



Interior Wire Harness Ground Point GB-029 Ground Wiring Diagram

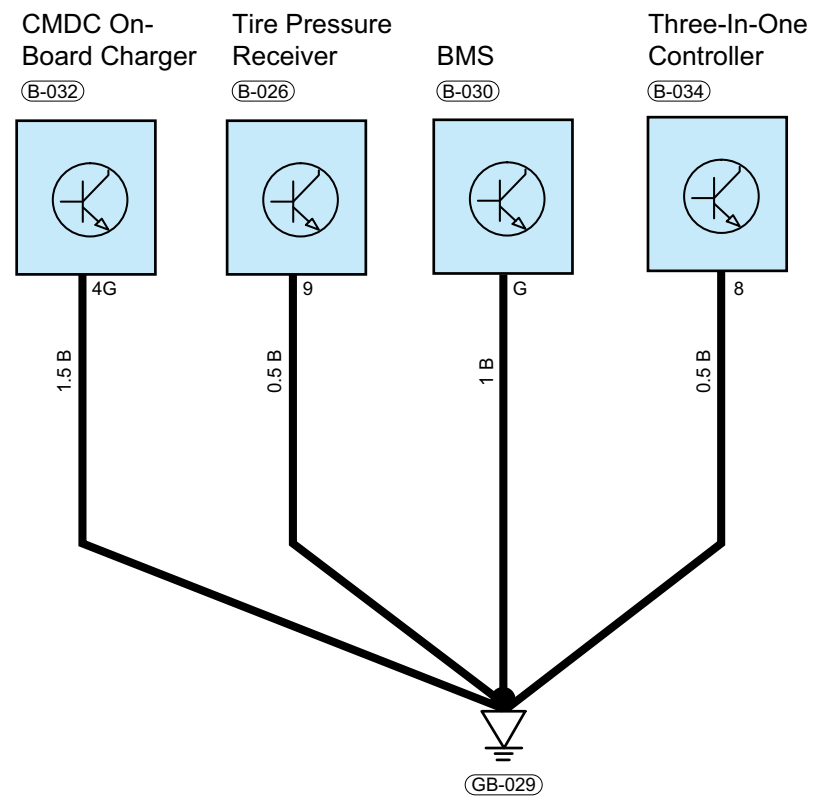
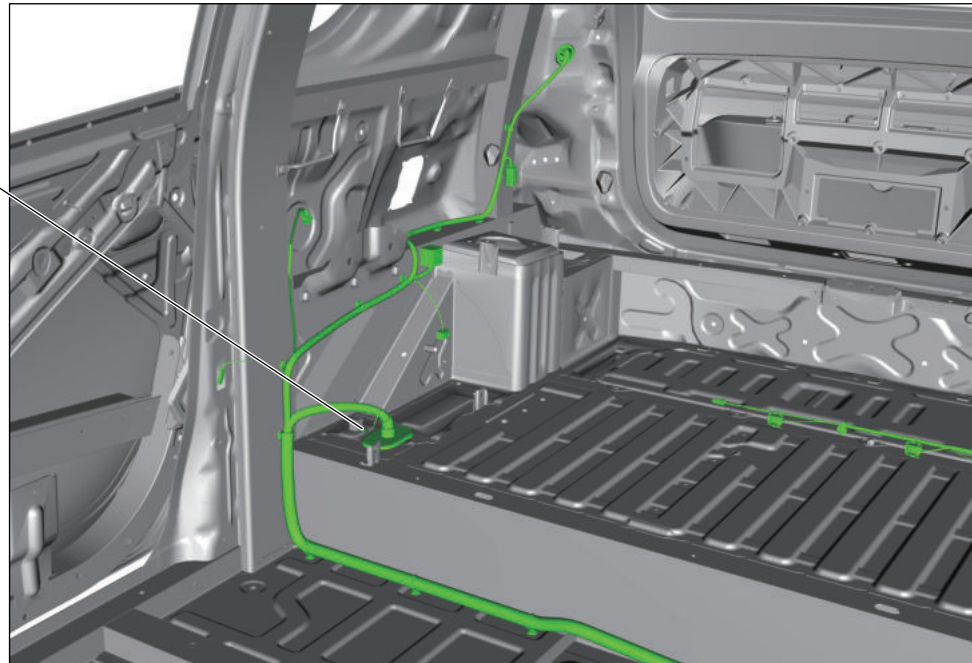

GDE0160

Meter Wire Harness Ground Point GI-041 Ground Wiring Diagram

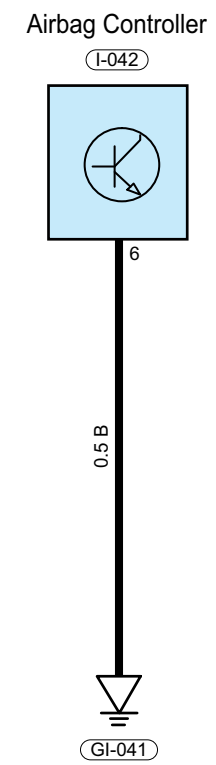
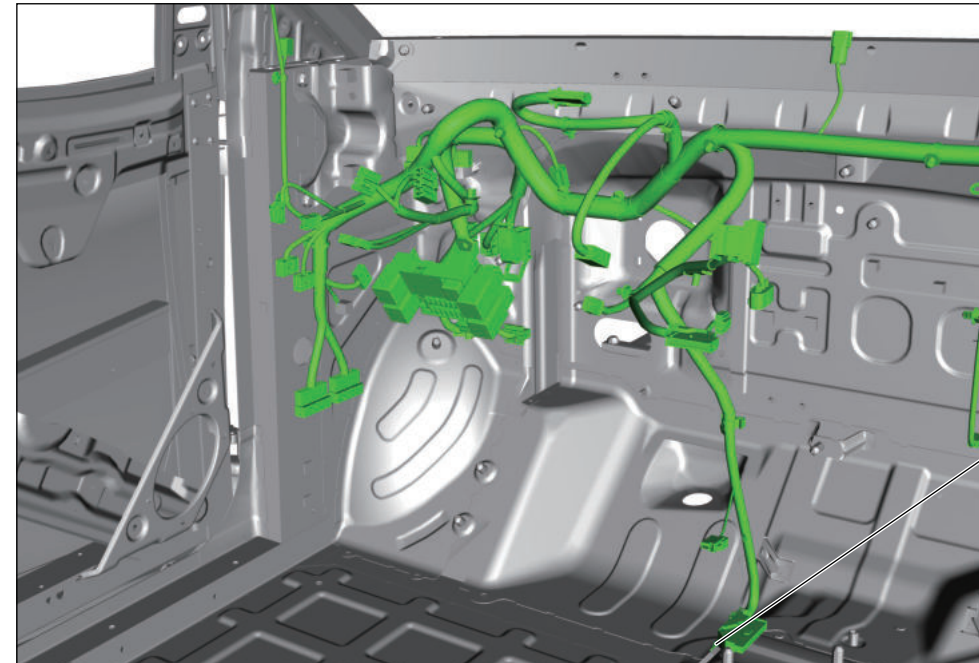

GDE0050

# Ground Point

Meter Wire Harness Ground Point GI-003 Ground Wiring Diagram

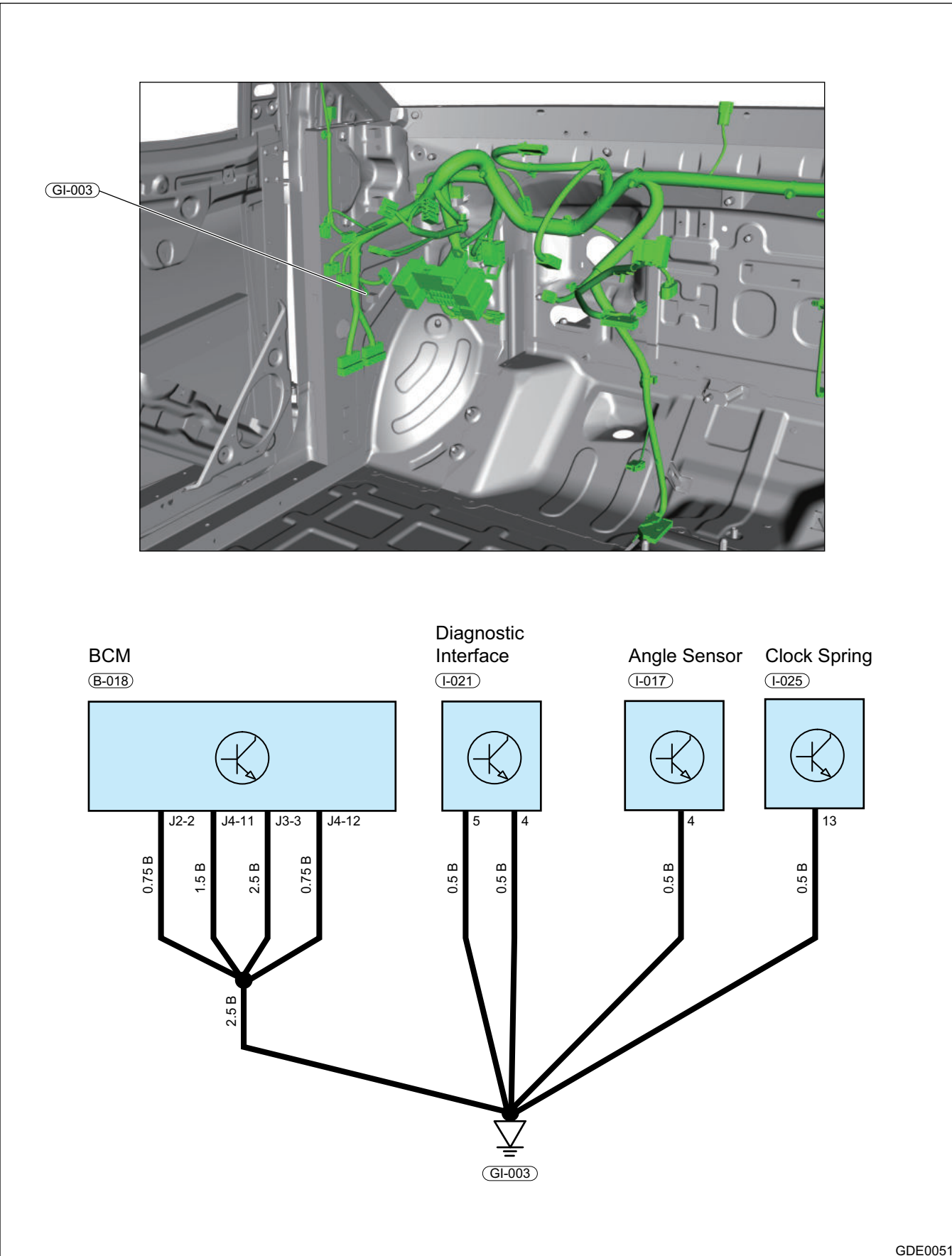

Meter Wire Harness Ground Point GI-003 Ground Wiring Diagram

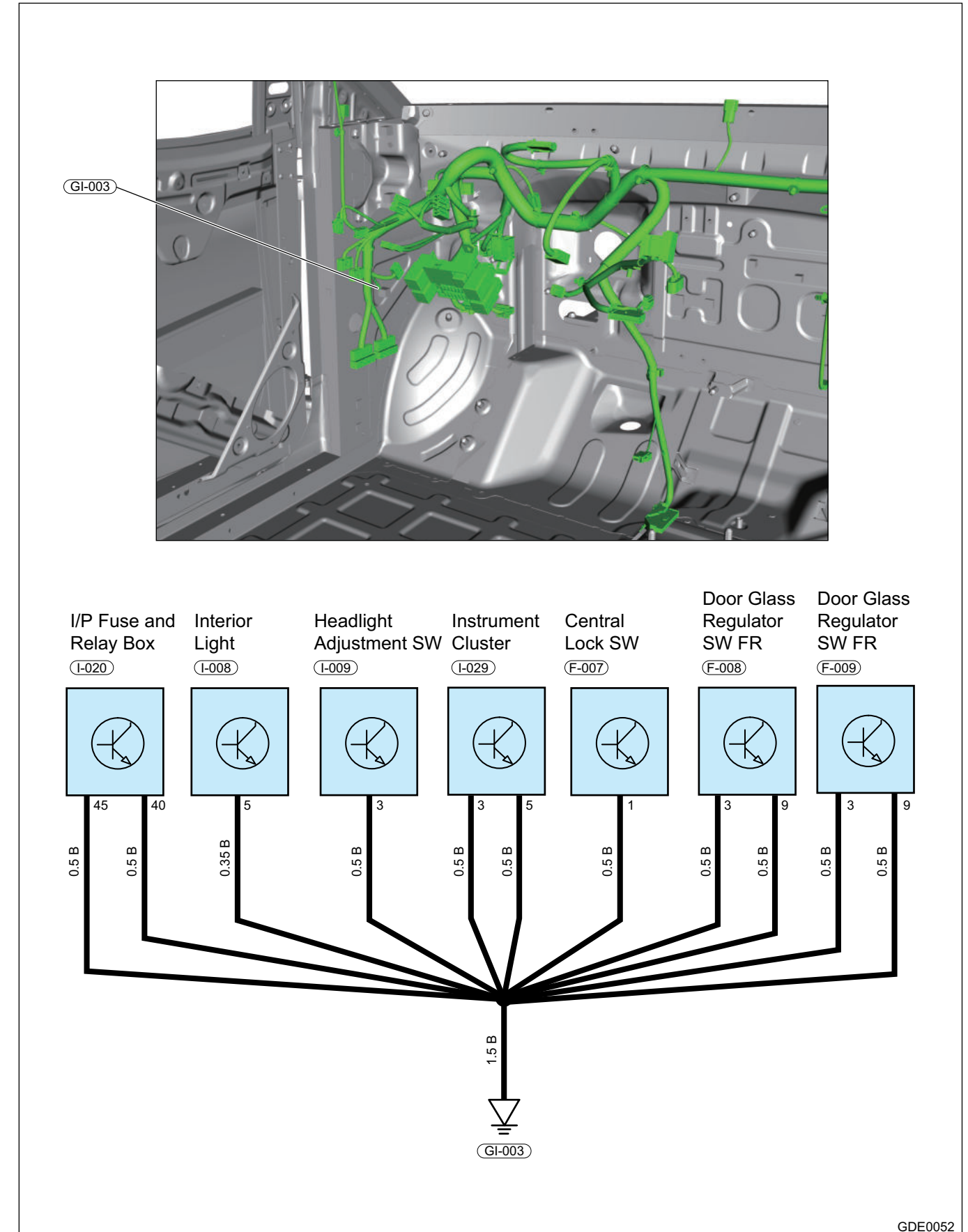



Meter Wire Harness Ground Point GI-003 Ground Wiring Diagram

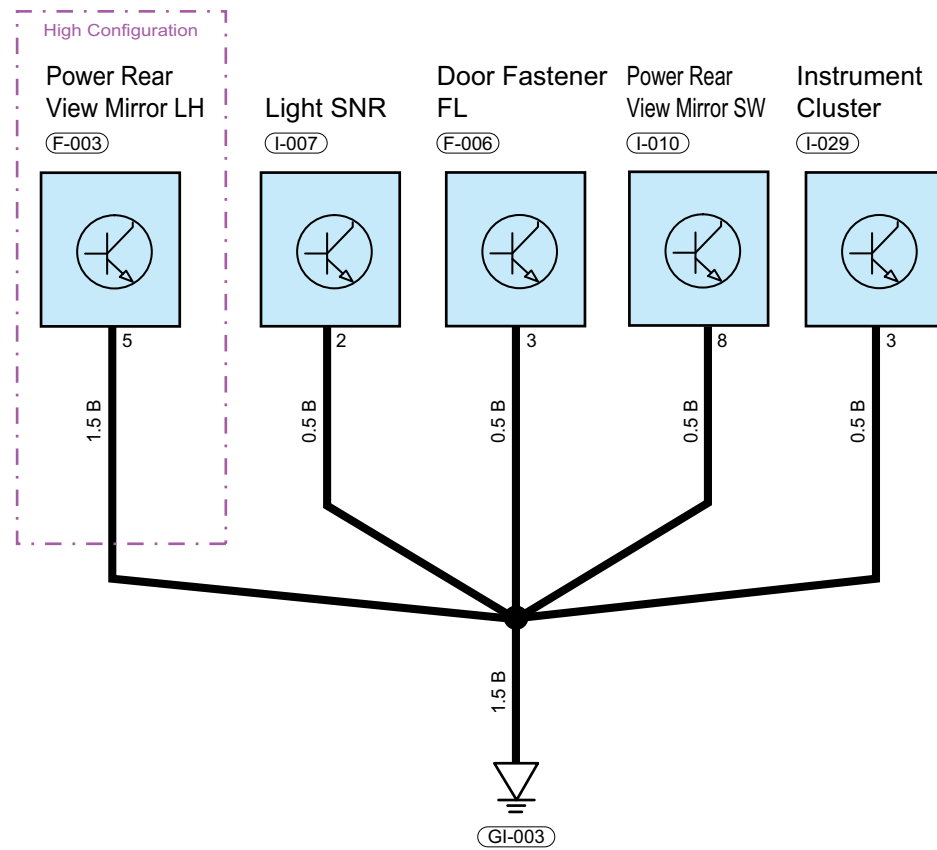
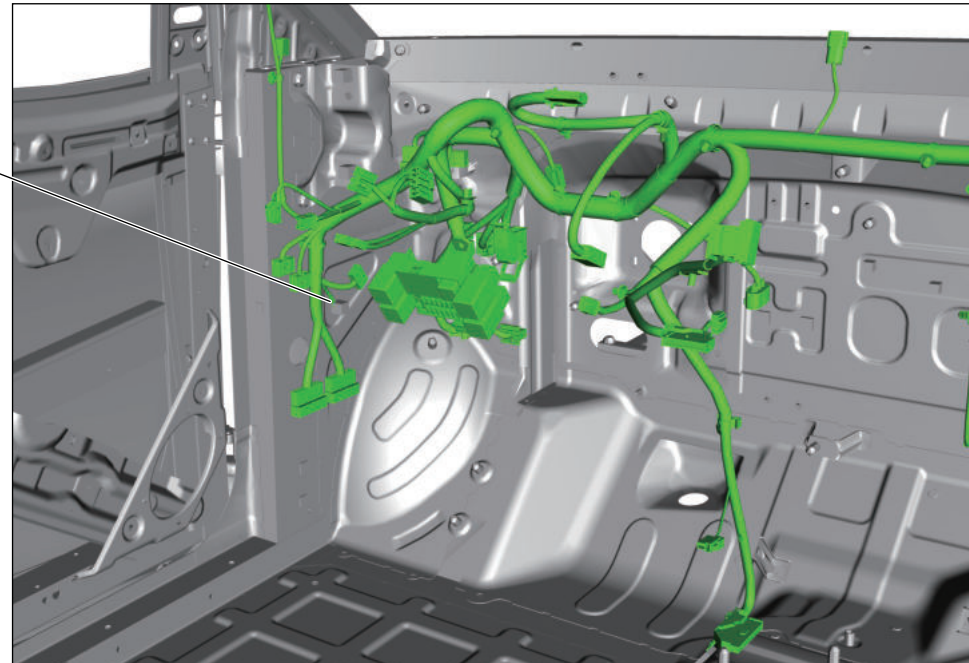

GDE0053

Meter Wire Harness Ground Point GI-044 Ground Wiring Diagram

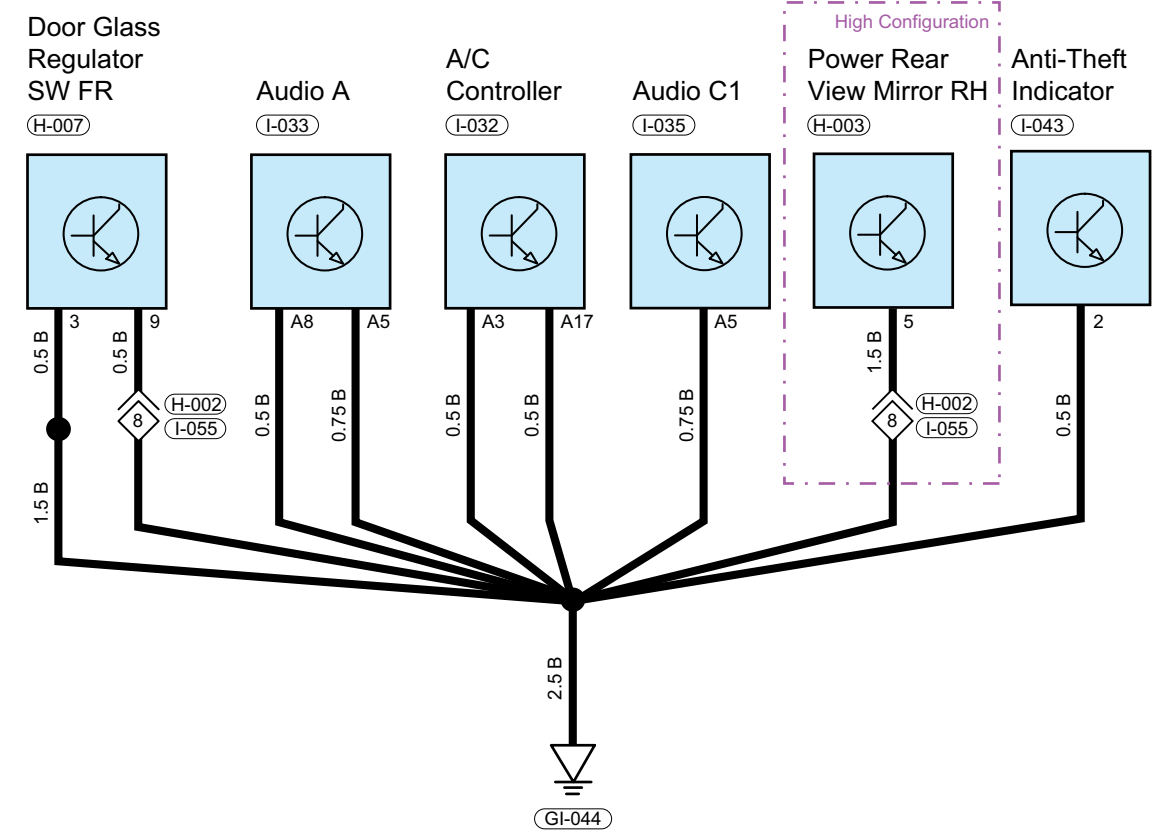
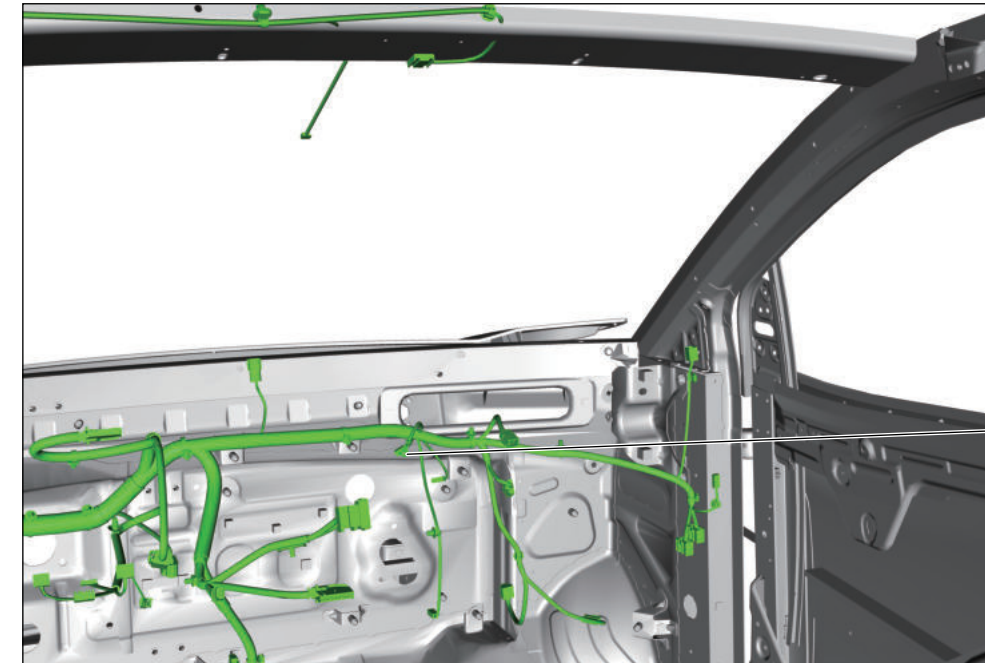

GDE0060

# Ground Point

Meter Wire Harness Ground Point GI-044 Ground Wiring Diagram

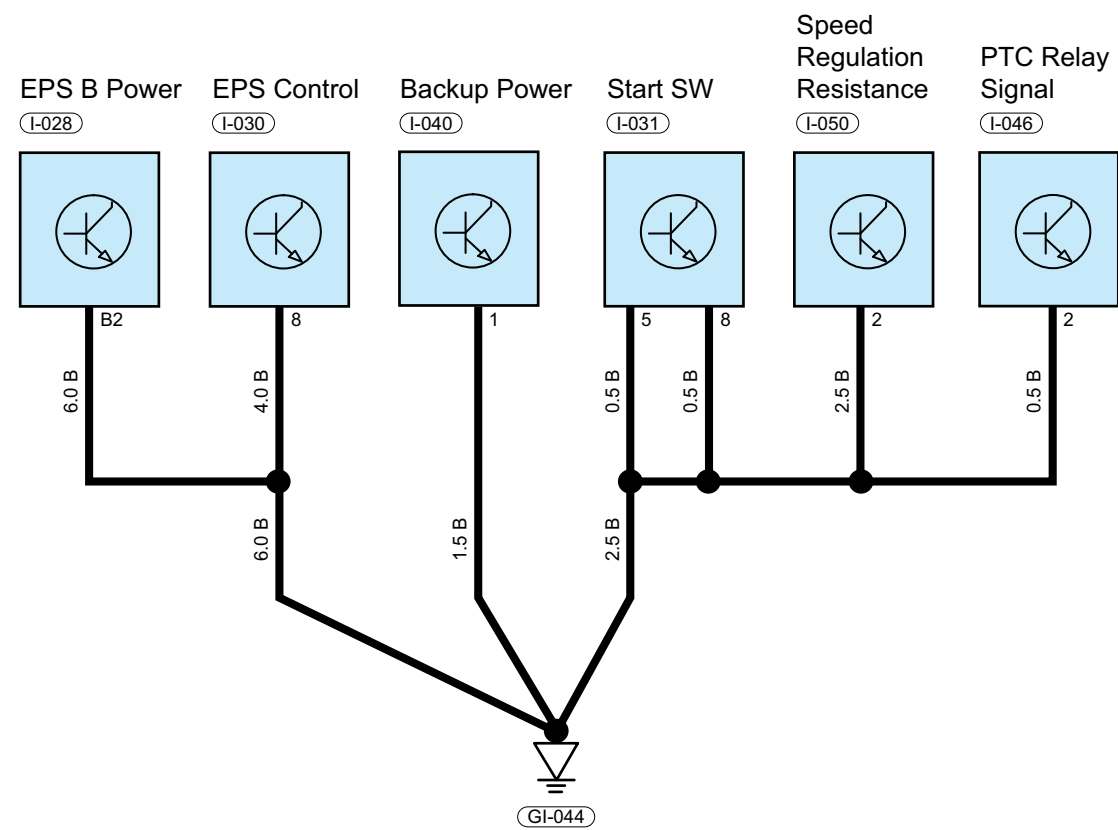
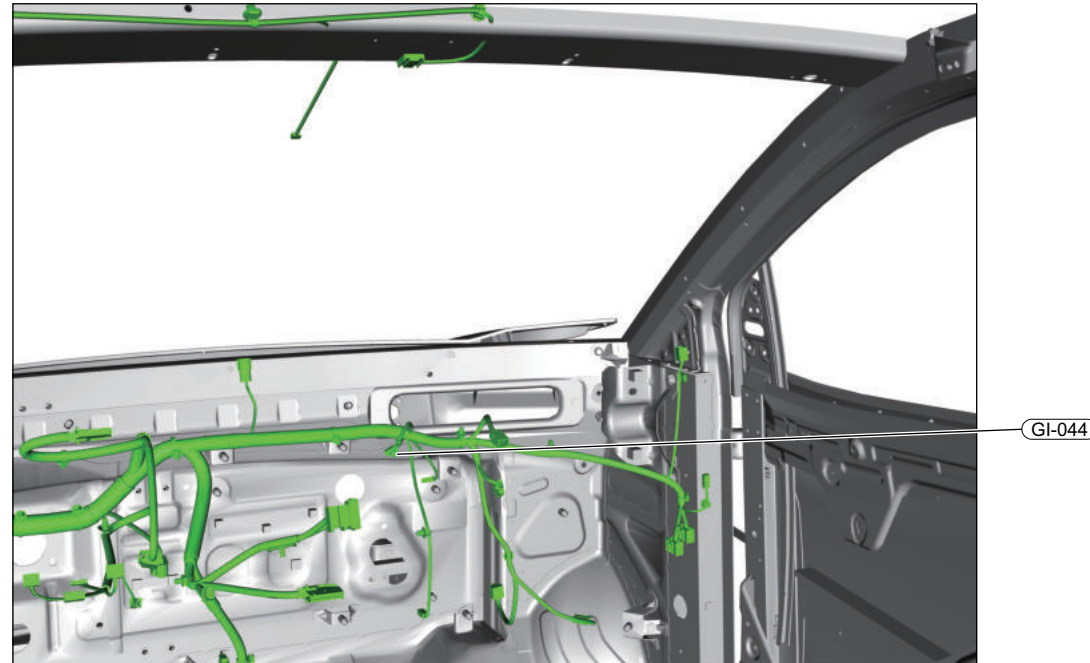

GDE0070

Battery Negative W/HA Harness Ground Point GN-002 Ground Wiring Diagram

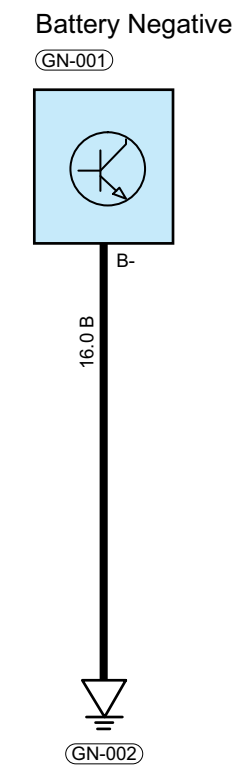
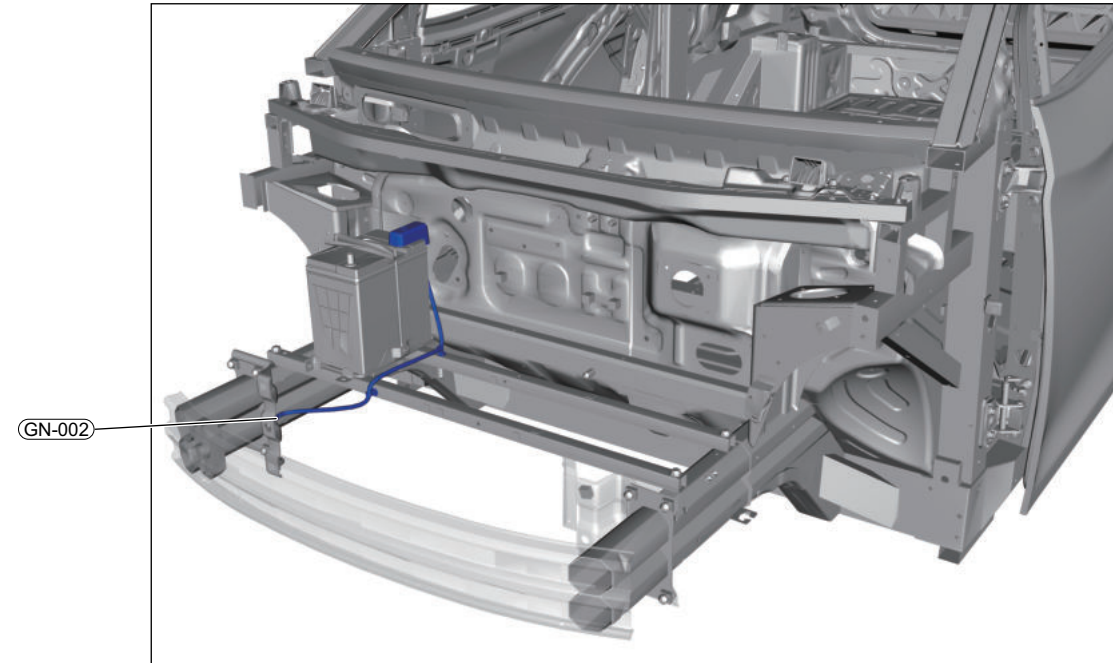

GDE0080

DCDC Harness Ground Point GN-004 Ground Wiring Diagram

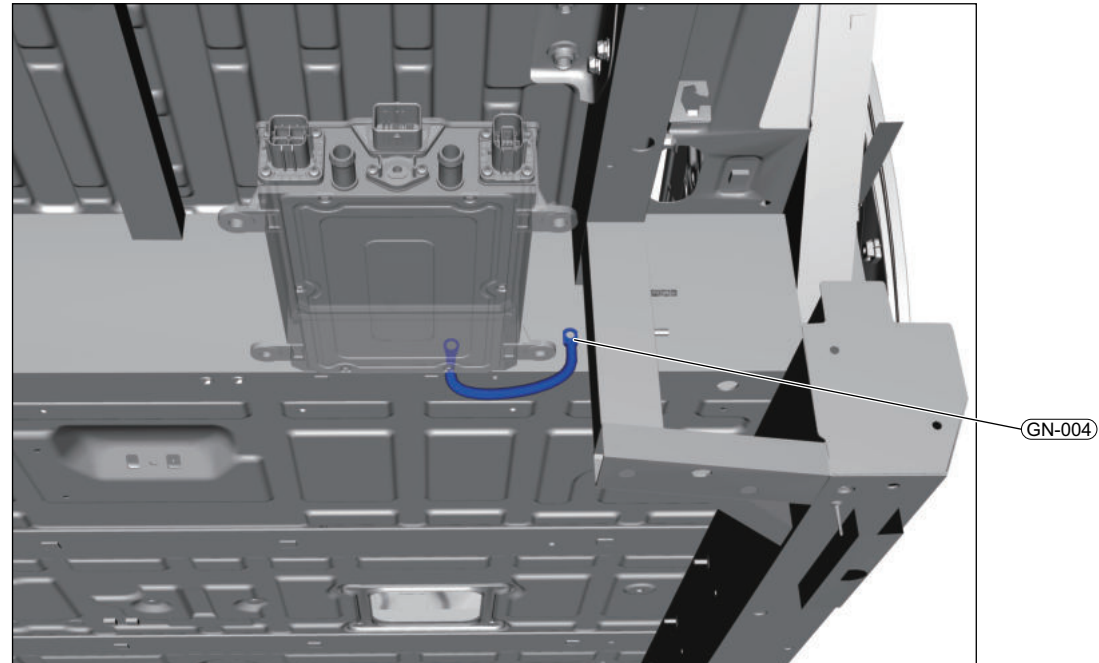

DC-DC Negative  
(GN-003)

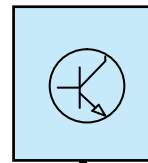

B

16.0 B



(GN-004)

GDE0090

Front Bumper Wire Harness Ground Point GQ-017/GQ-018 Ground Wiring Diagram

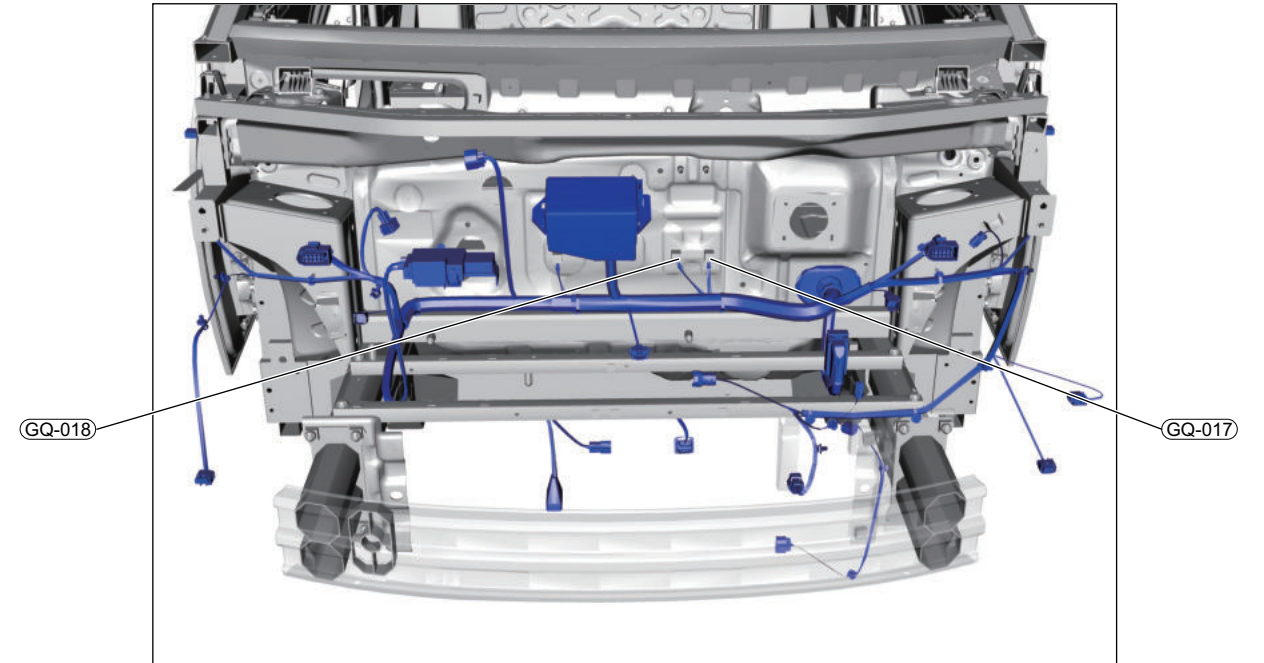

I/P Fuse and  
Relay Box  
(I-020)

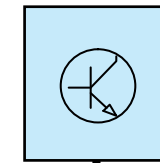

39

0.75 B

Brake FLuid  
Level SNR  
(Q-011)

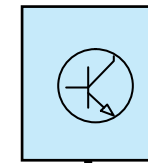

2

0.5 B

0.75 B



(GQ-018)

ESC Controller  
(Q-015)

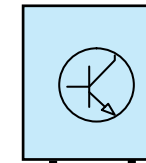

38

2.5 B

13

4.0 B

4.0 B



(GQ-017)

GDE0100



# Ground Point

## Front Bumper Wire Harness Ground Point GQ-018 Ground Wiring Diagram

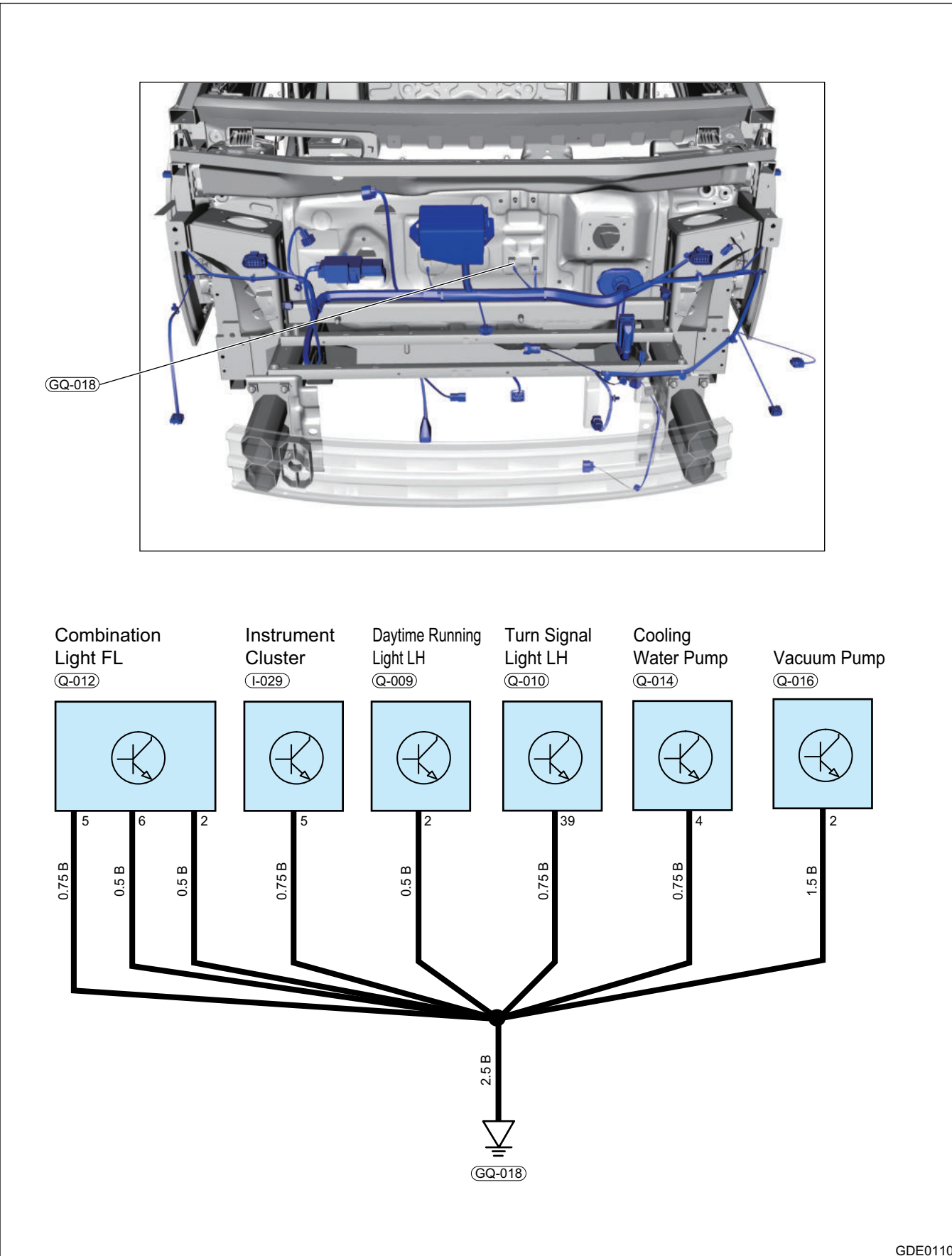

## Front Bumper Wire Harness Ground Point GQ-021 Ground Wiring Diagram

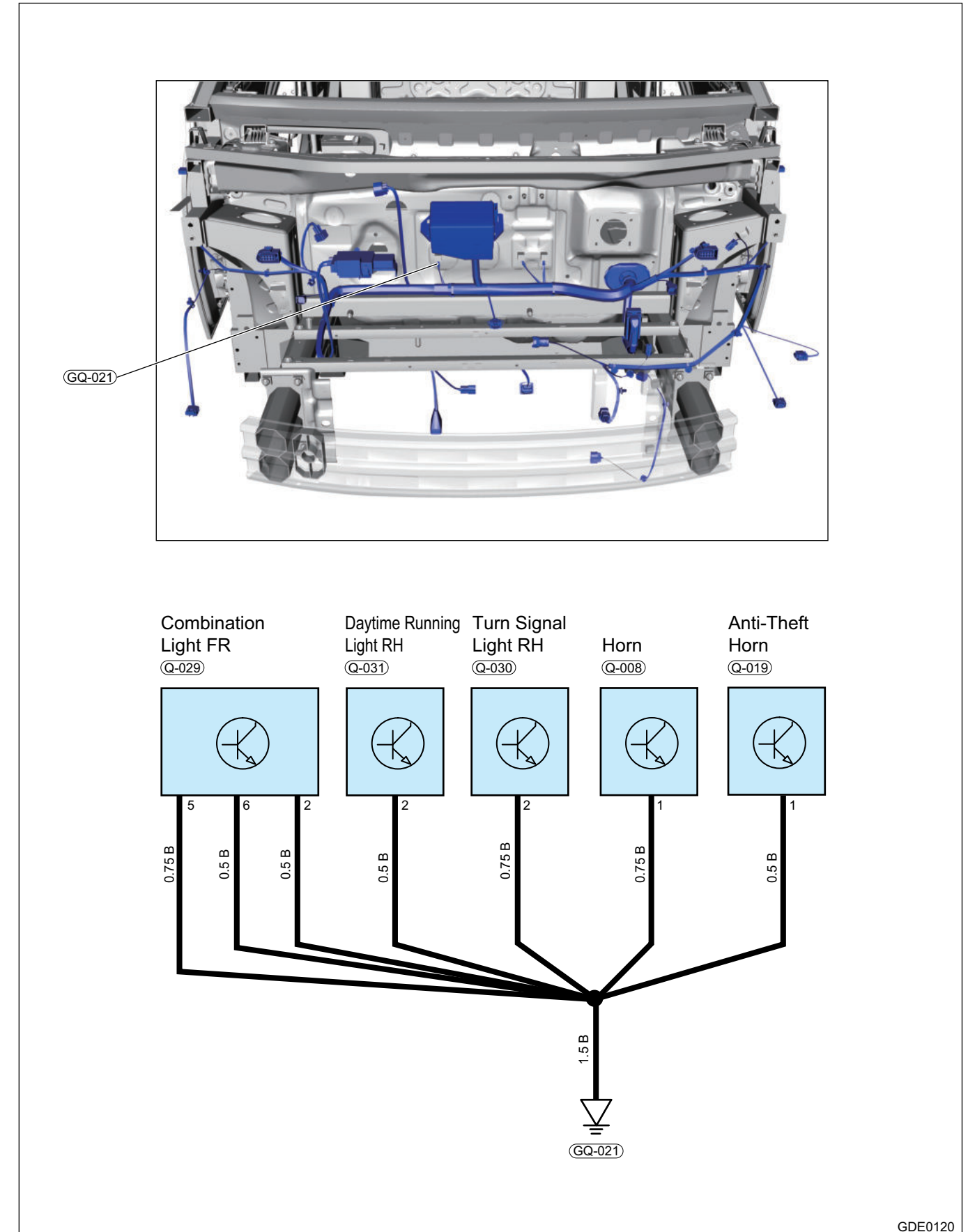

Front Bumper Wire Harness Ground Point GQ-021 Ground Wiring Diagram

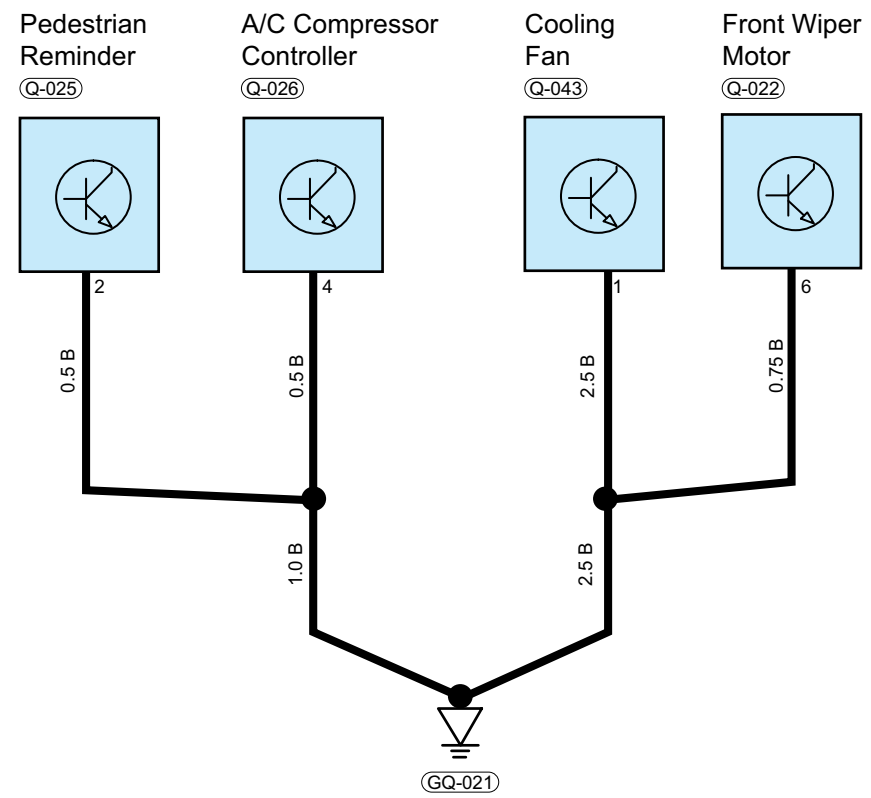
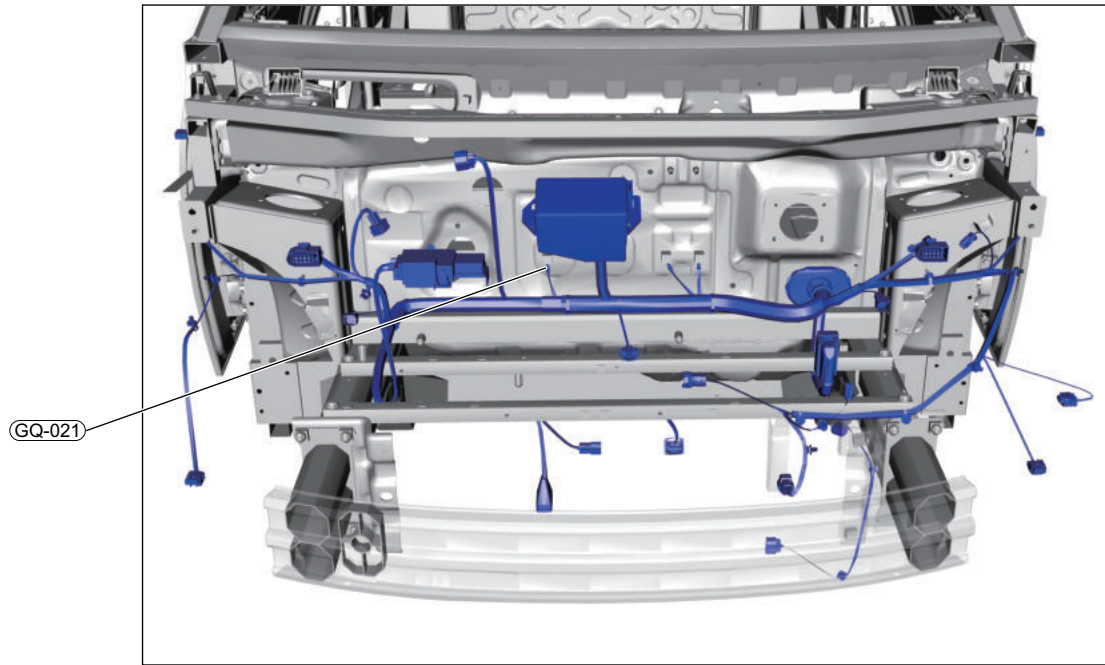

GDE0130



# Wire Harness Position Diagram

## Vehicle Wiring Harness Layout Diagram

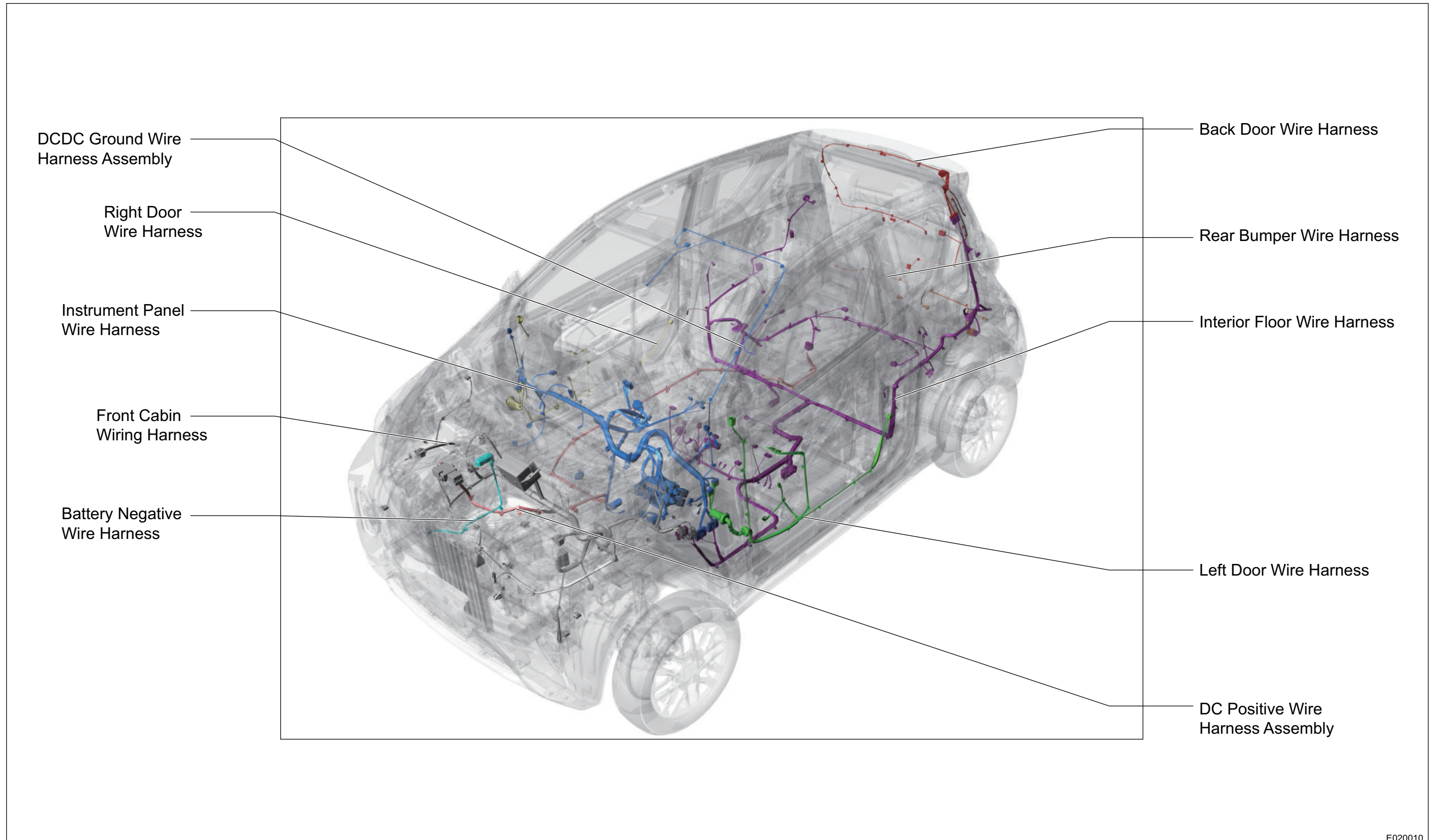

E020010

Wire Harness Connector Location in Real Vehicle

Front Cabin Wiring Harness to Indoor Wiring Harness Connector

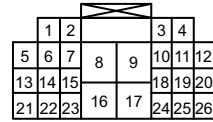

(B-002)  
B

To Front Compartment W/HA B

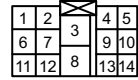

(B-001)  
B

To Front Compartment W/HA A

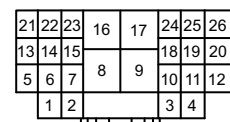
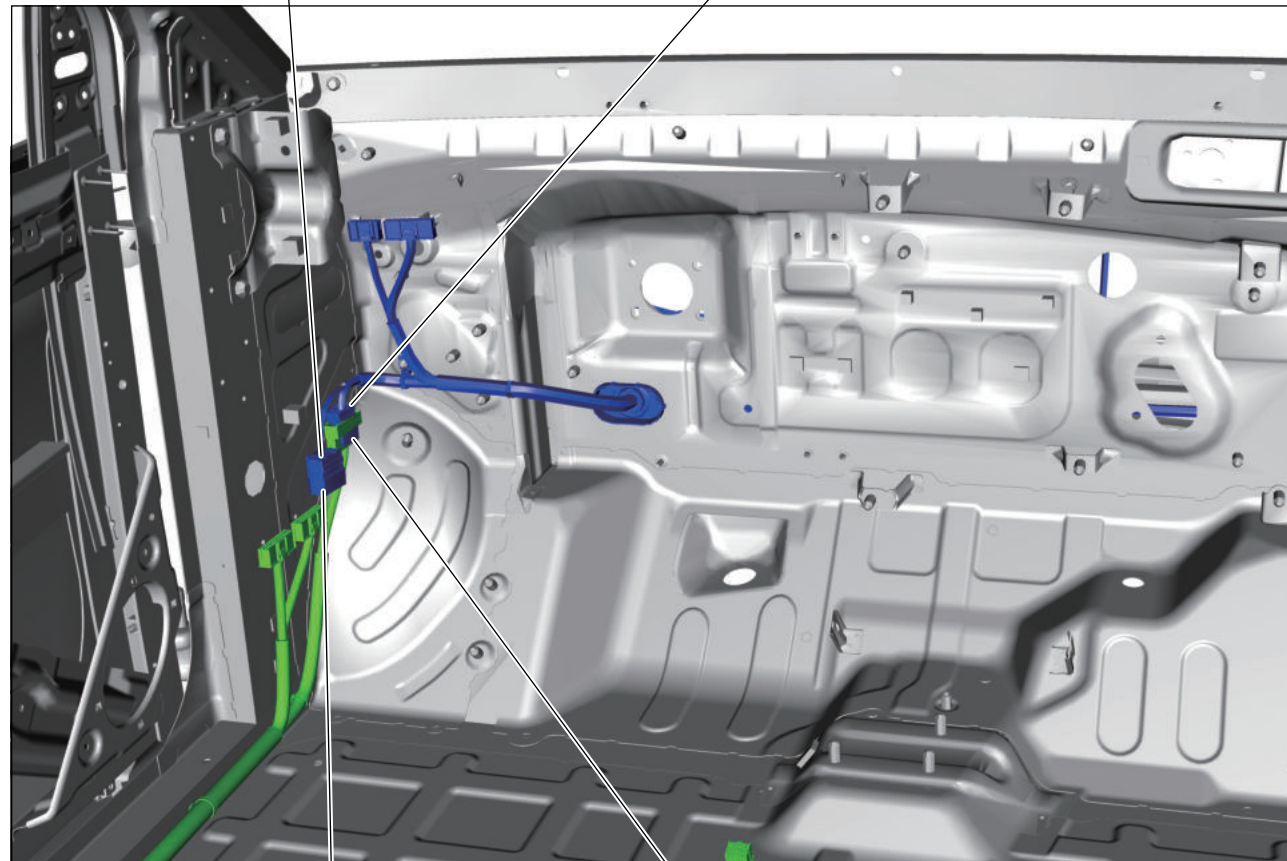

(Q-002)  
B

To Interior W/HA B



(Q-001)  
B

To Interior W/HA A

Front Cabin Wiring Harness to Instrument Wiring Harness Connector



(I-011)  
B

To Front Compartment W/HA 2

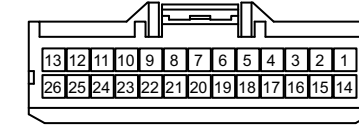

(I-012)  
B

To Front Compartment W/HA 1

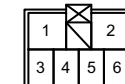
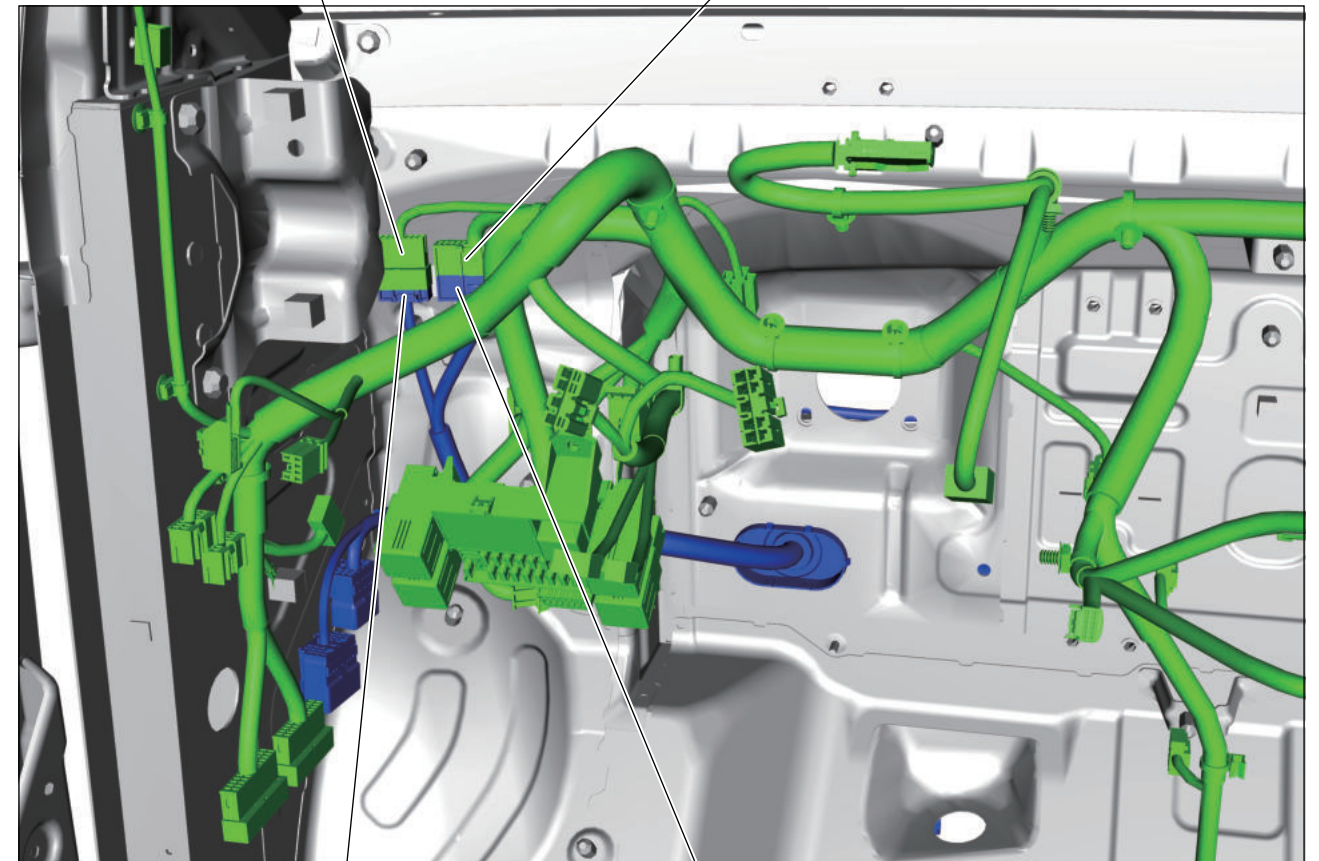

(Q-003)  
B

To I/P W/HA 2

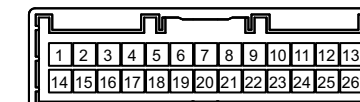

(Q-004)  
B

To I/P W/HA 1



# Wire Harness Position Diagram

## Indoor Wiring Harness Is Connected to Rear Wiring Harness Connector

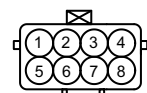
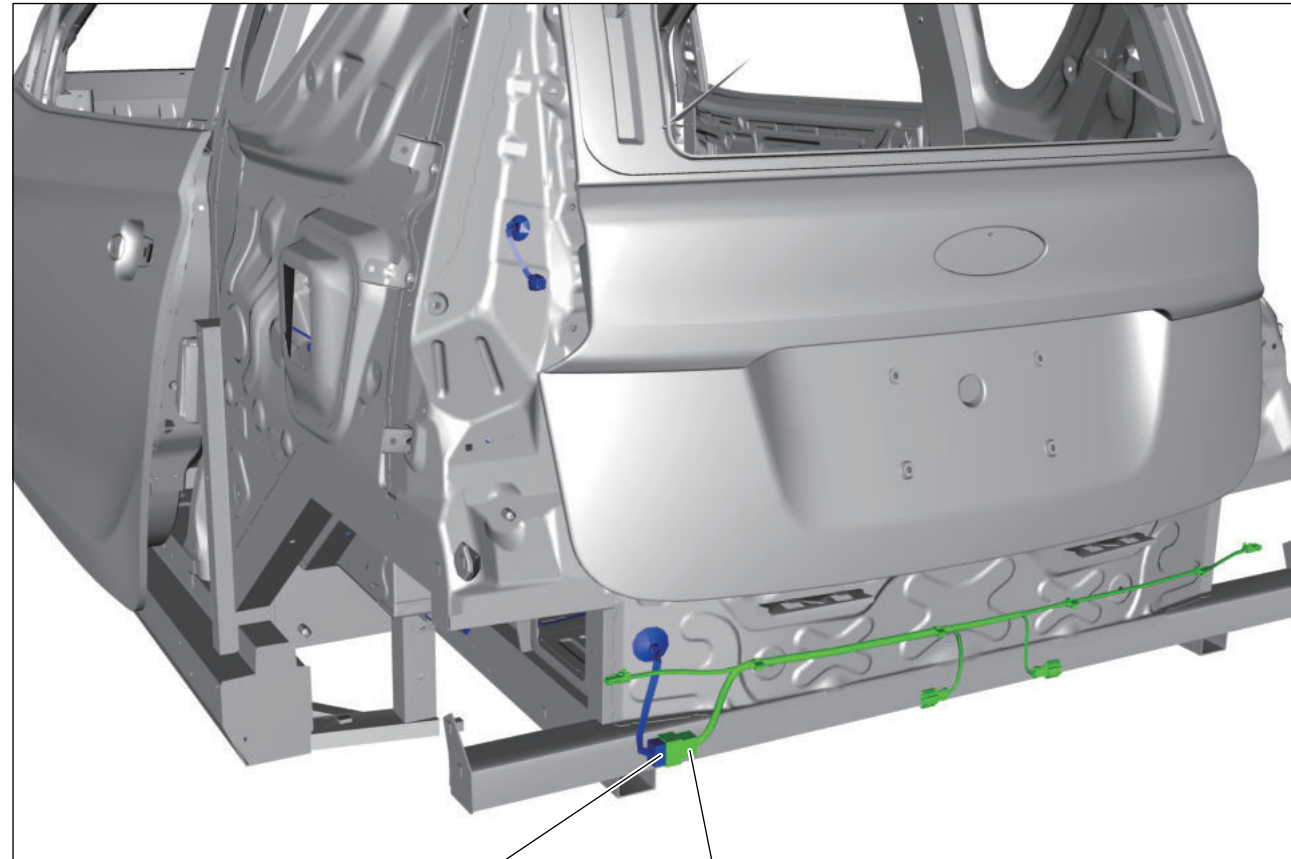

(B-041)  
B

To Rear Bumper W/HA

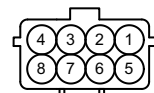

(J-001)  
B

To Interior W/HA

E010030

## Interior Wire Harness to Rear Right Door Wire Harness Connector

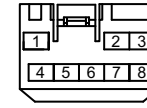
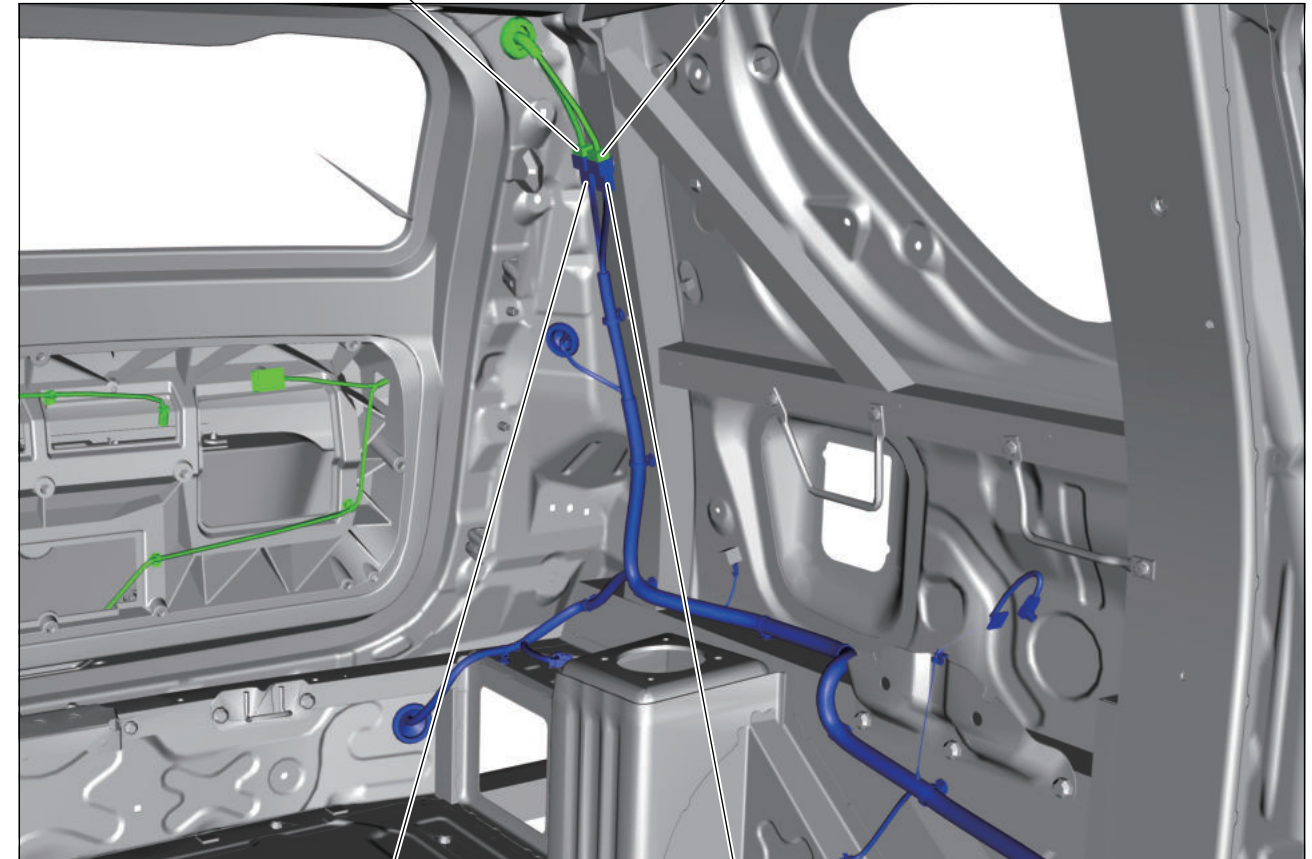

(T-001)  
B

To Interior W/HA 1

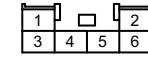

(T-002)  
B

To Interior W/HA 2

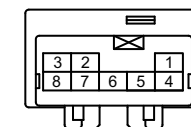

(B-042)  
B

To Back Door W/HA 1

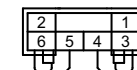

(B-043)  
B

To Back Door W/HA 2

E010040

Interior Wire Harness to Meter Wire Harness Connector

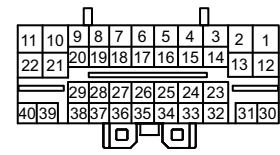

I-002  
B

To Interior W/HA B

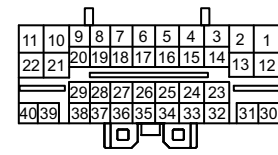

I-001  
B

To Interior W/HA C

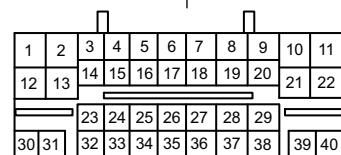
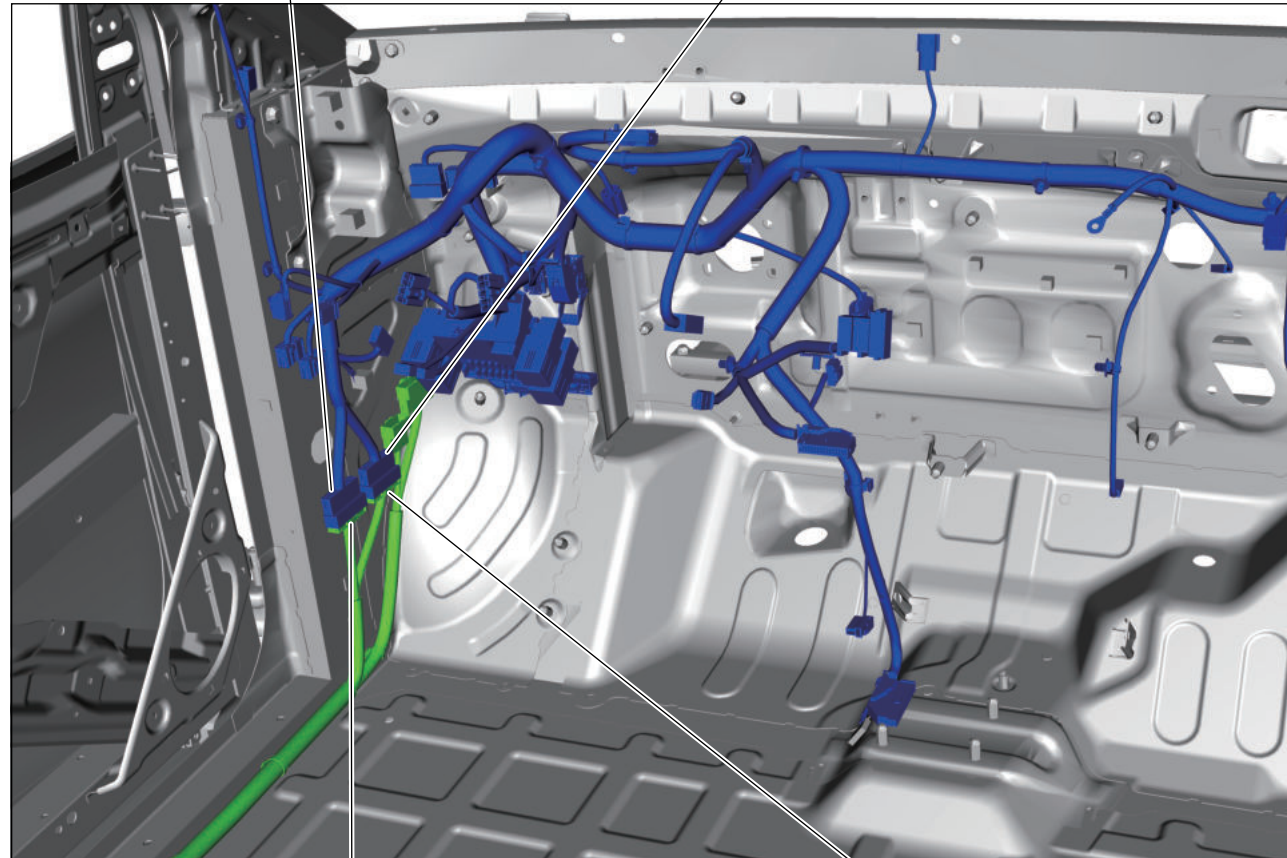

B-003  
B

To I/P W/HA B

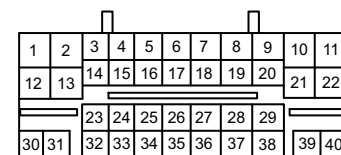

B-004  
B

To I/P W/HA C

E010050

Interior Wire Harness to Right Door Wire Harness Connector

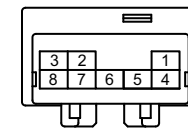

I-055  
B

To Door W/HA FR B

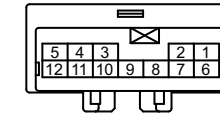

I-054  
B

To Door W/HA FR A

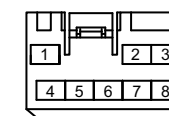
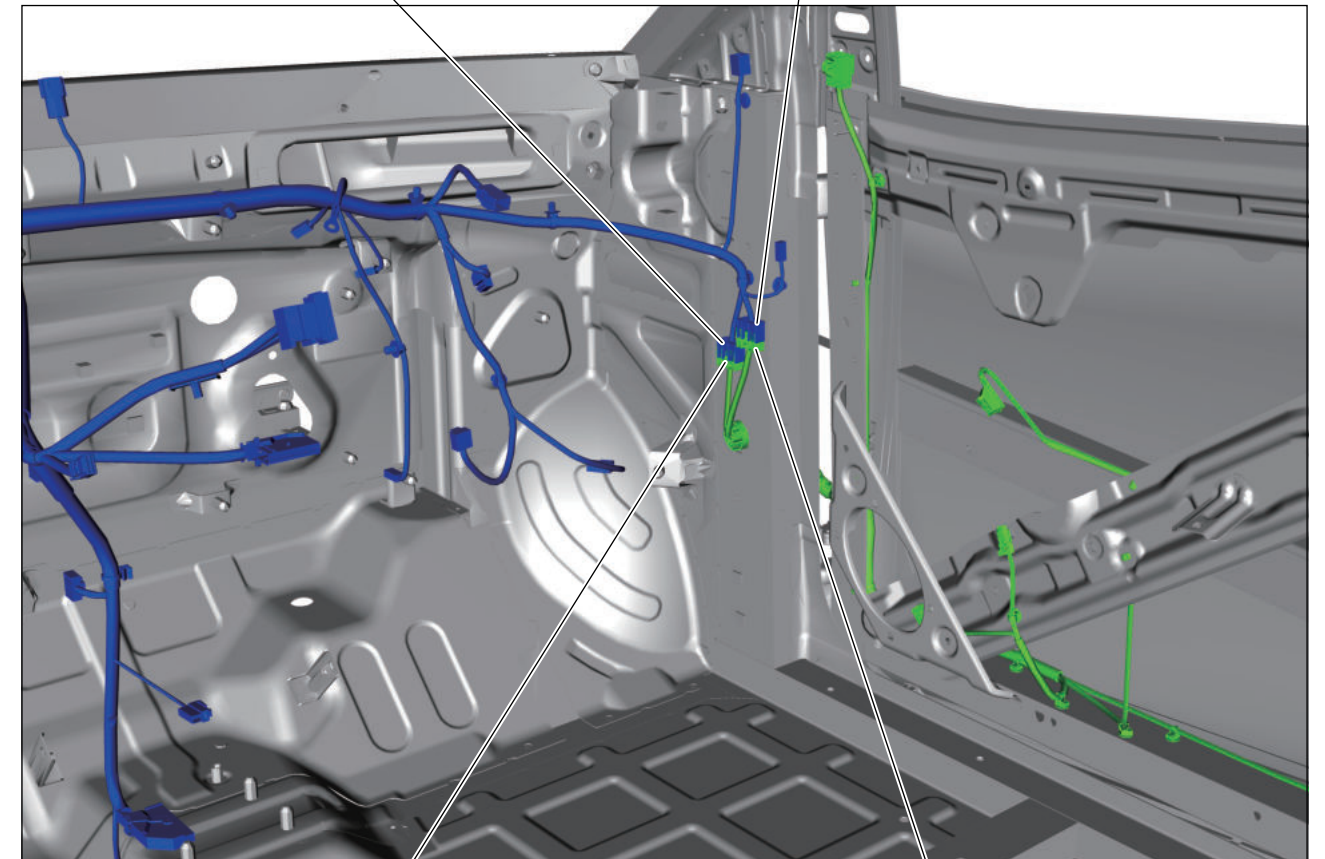

H-002  
B

To I/P W/HA B

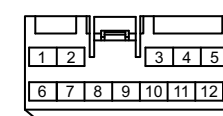

H-001  
B

To I/P W/HA

E010060



# Wire Harness Position Diagram

## Interior Wire Harness to Left Door Wire Harness Connector

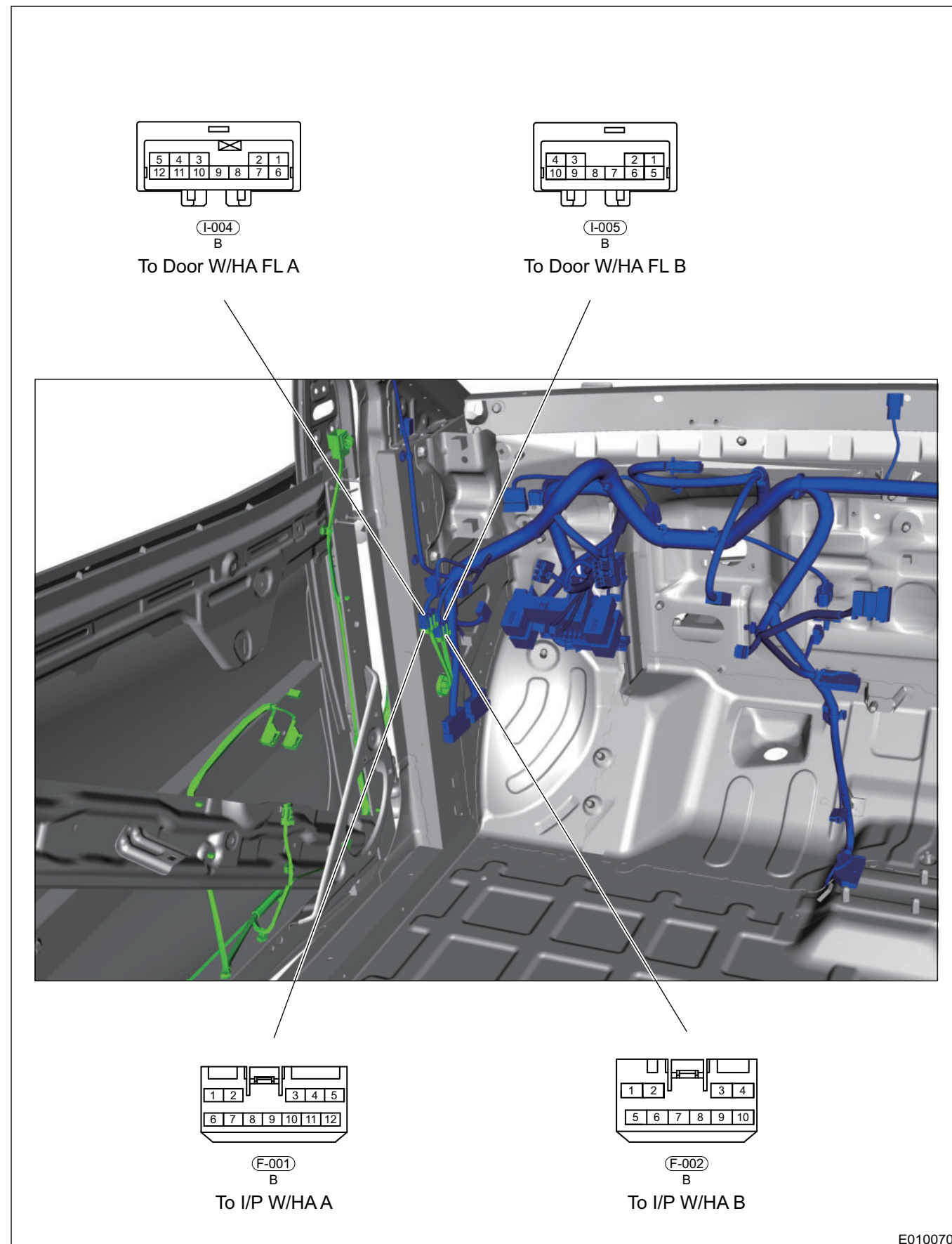

E010070

# Front Cabin Wiring Harness Assembly

## Front Cabin Wiring Harness Assembly

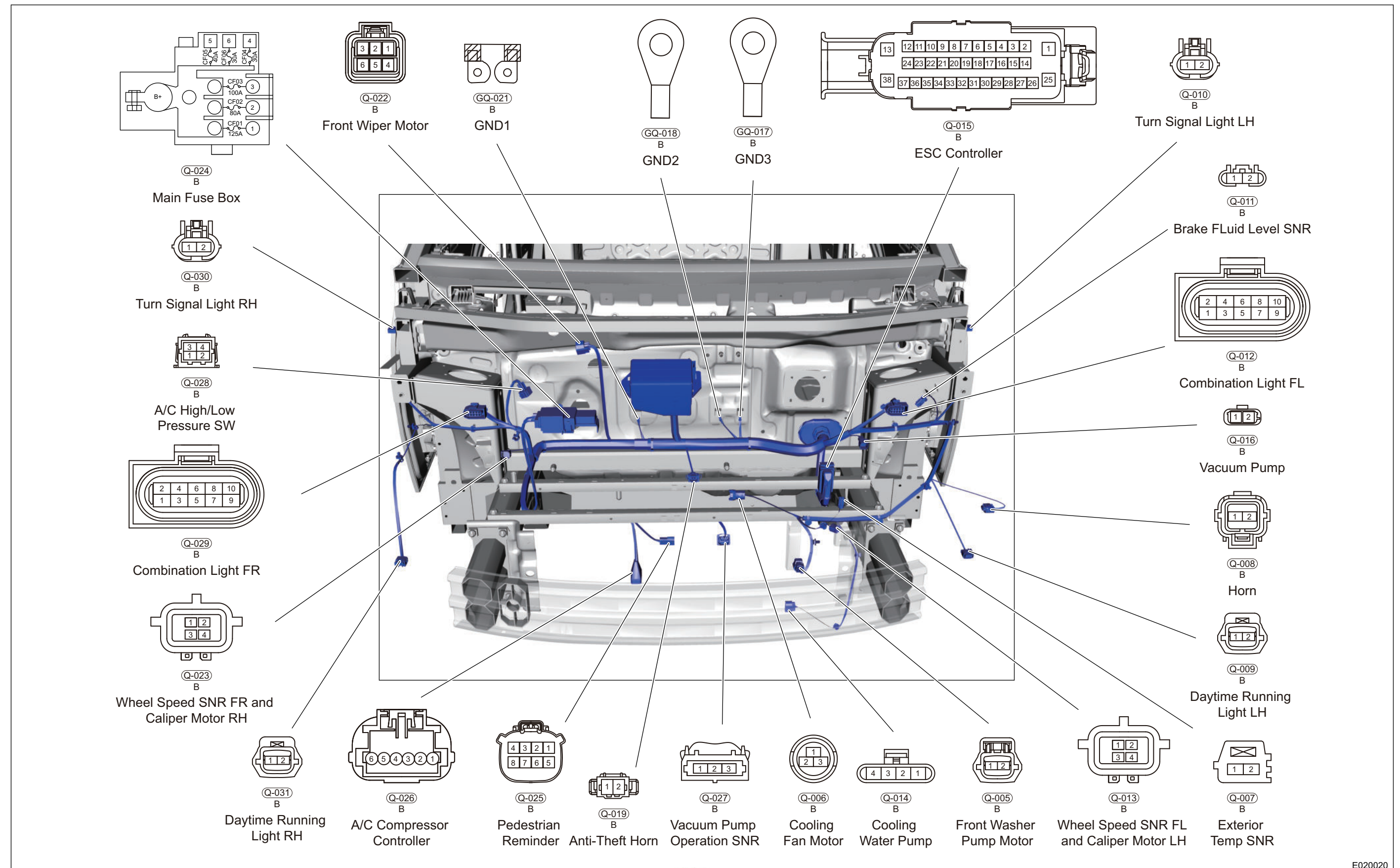

E020020



Instrument Panel Wire Harness Connector Location Diagram

Instrument Panel Wire Harness Connector Location Diagram (1/3)

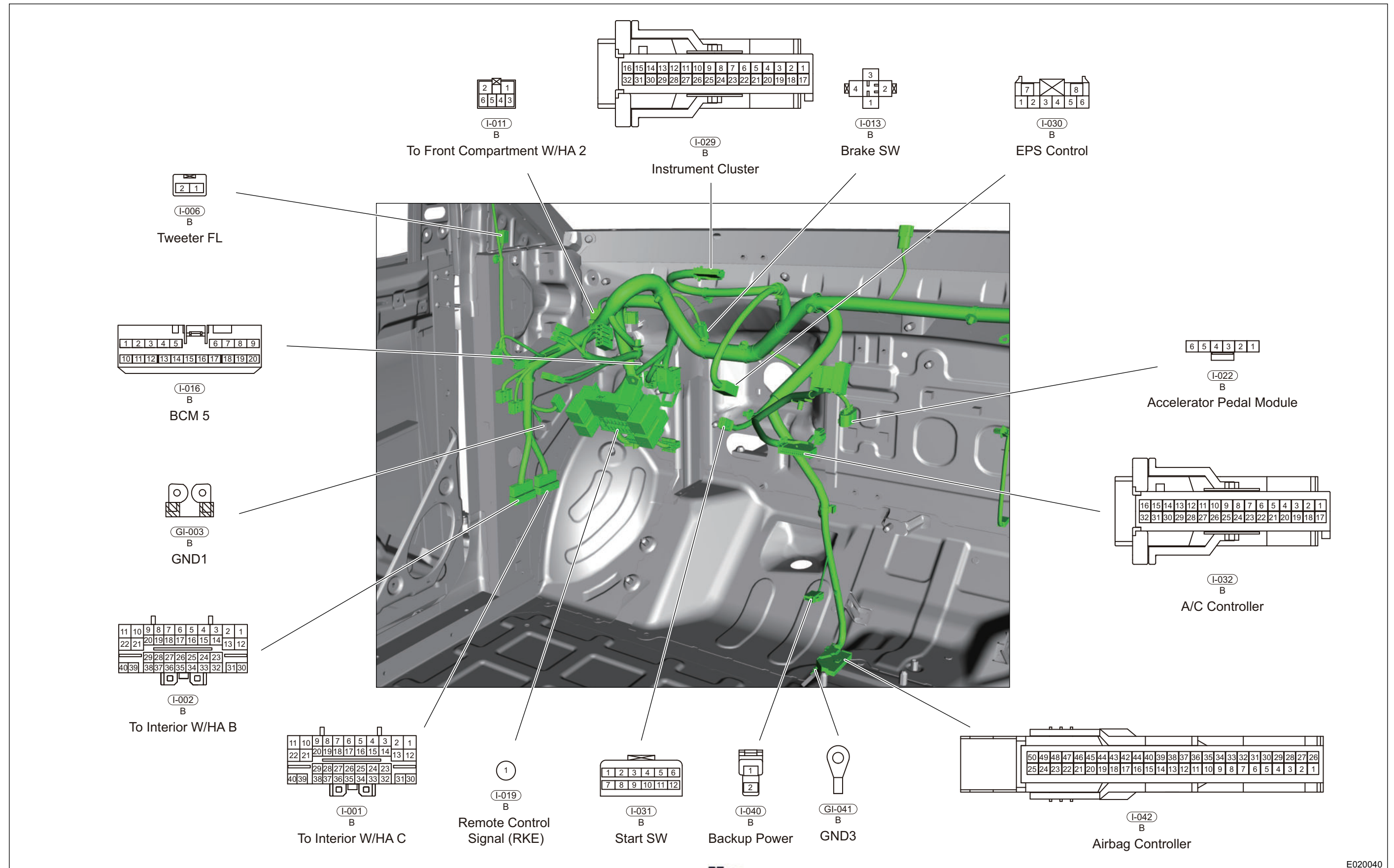

Instrument Panel Wire Harness Connector Location Diagram (2/3)

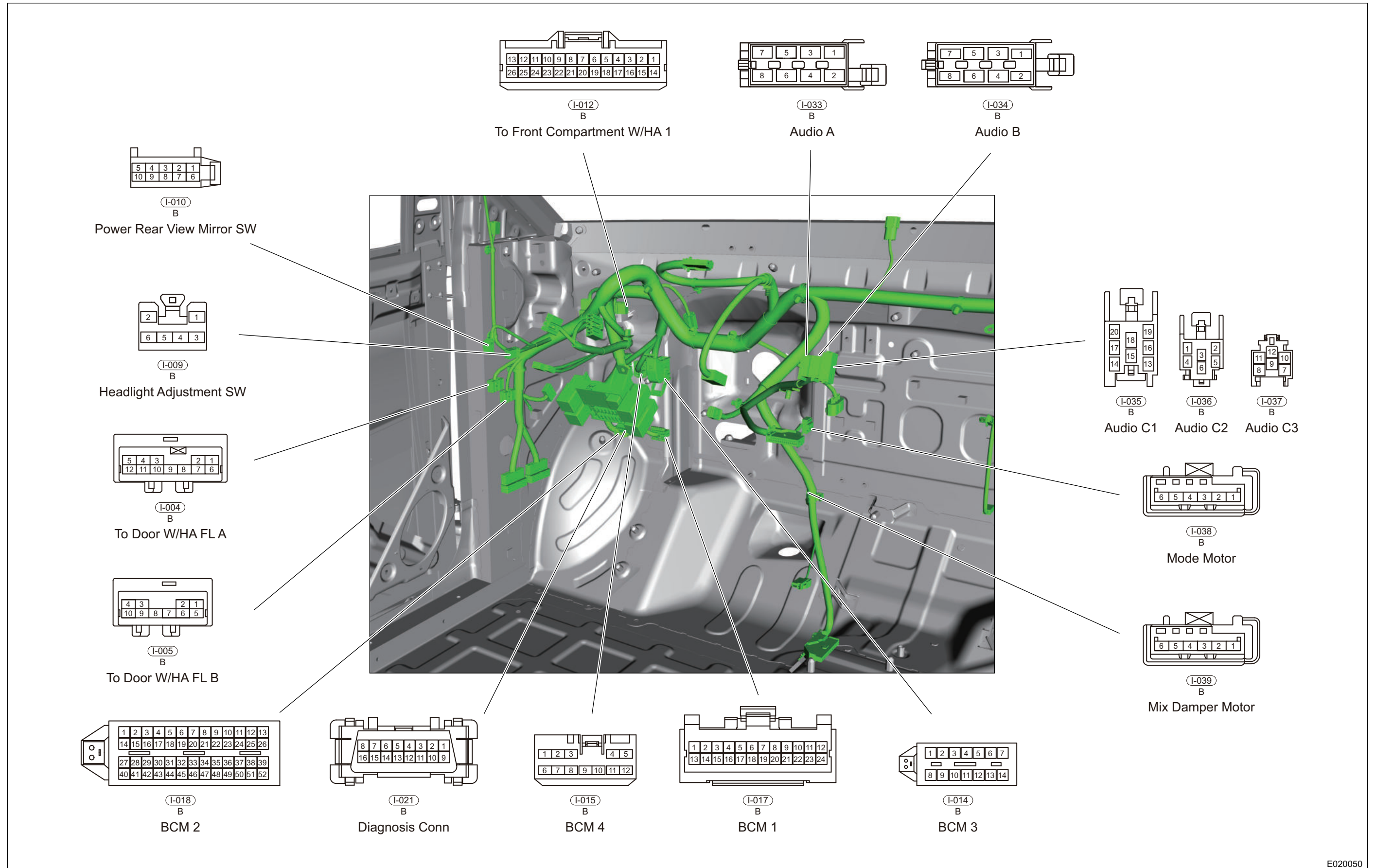



# Wire Harness Position Diagram

## Instrument Panel Wire Harness Connector Location Diagram (3/3)

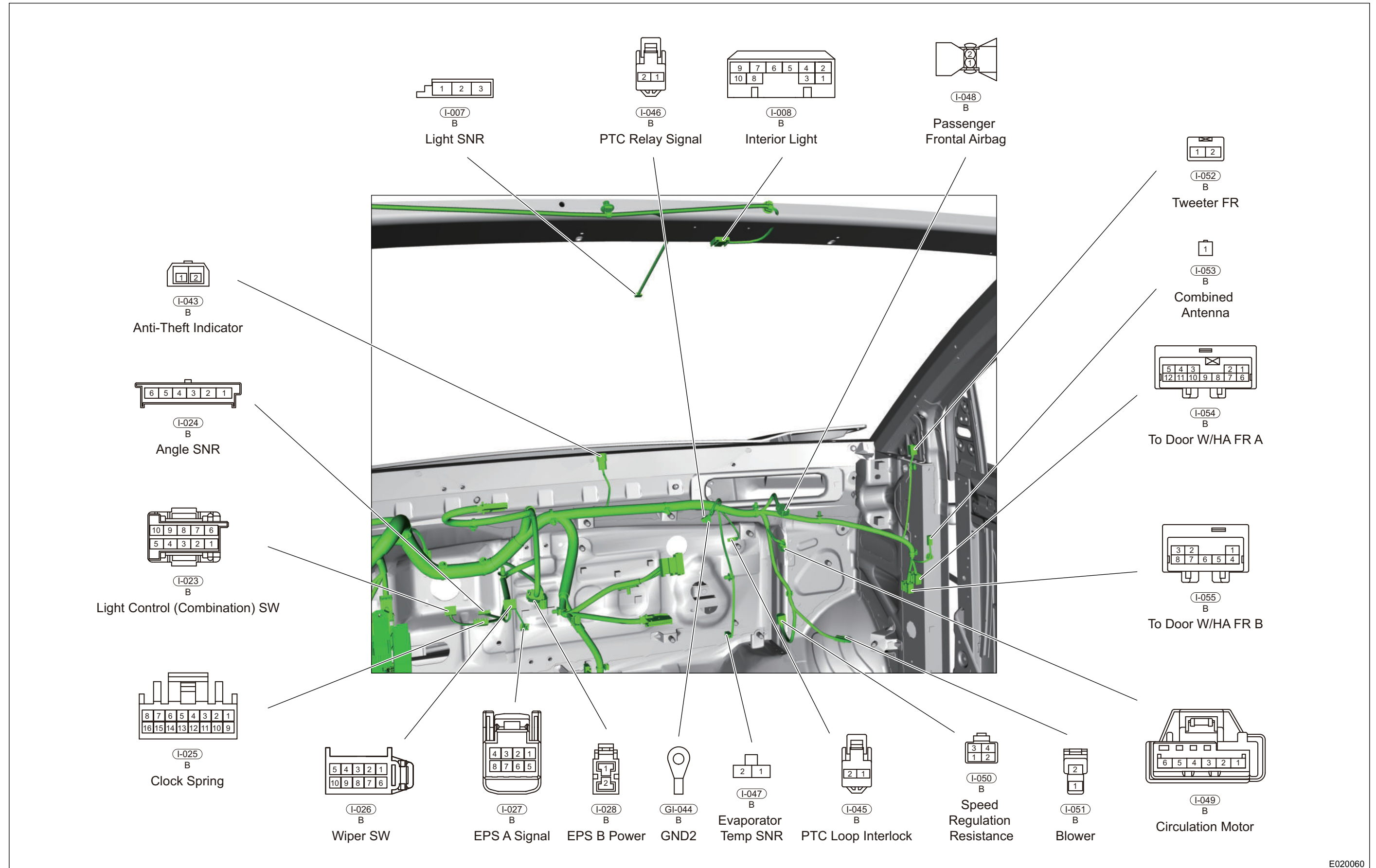

E020060

Interior Floor Wire Harness Connector Location Diagram

Interior Floor Wire Harness Connector Location Diagram (1/4)

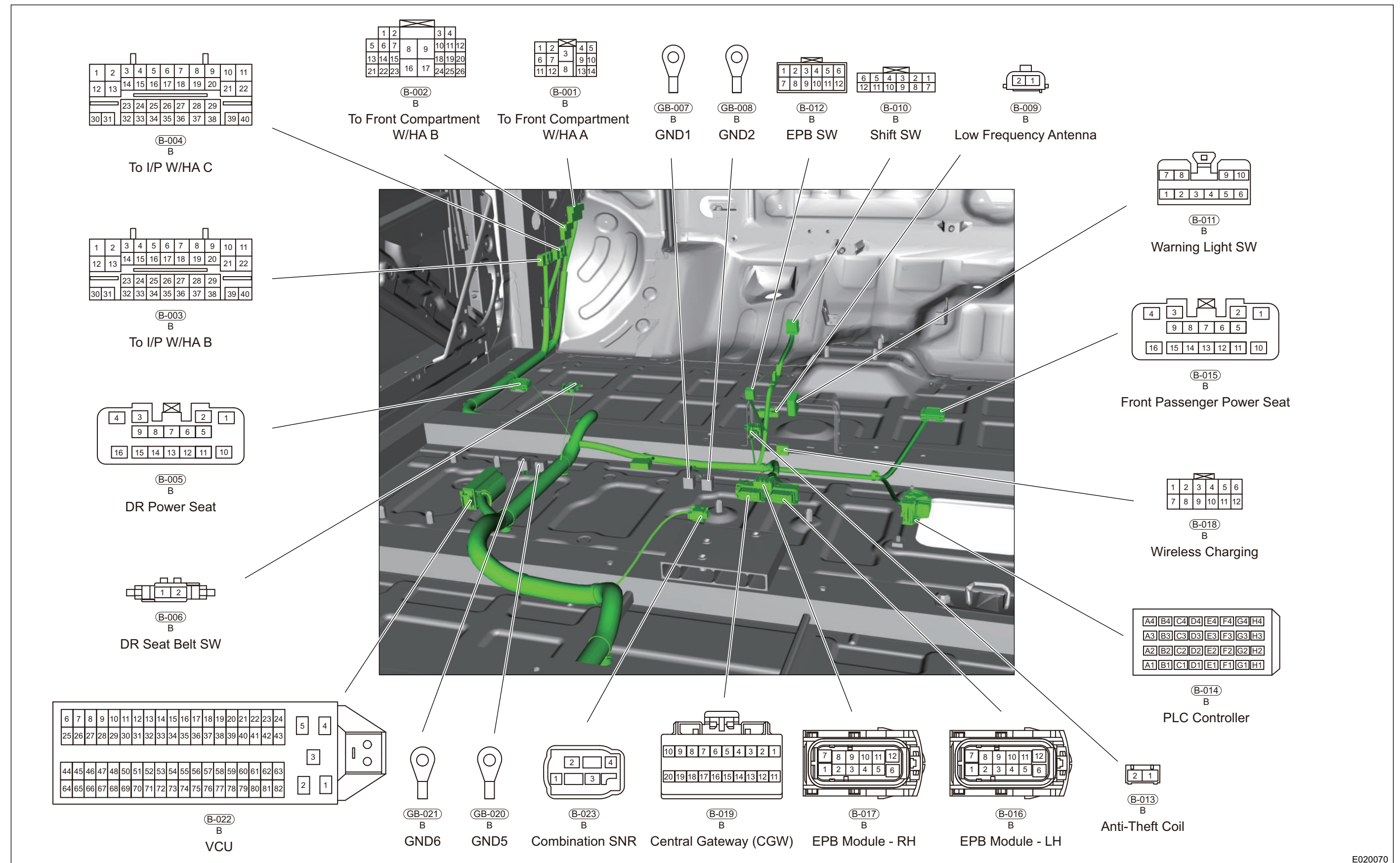

E020070



# Wire Harness Position Diagram

## Interior Floor Wire Harness Connector Location Diagram (2/4)

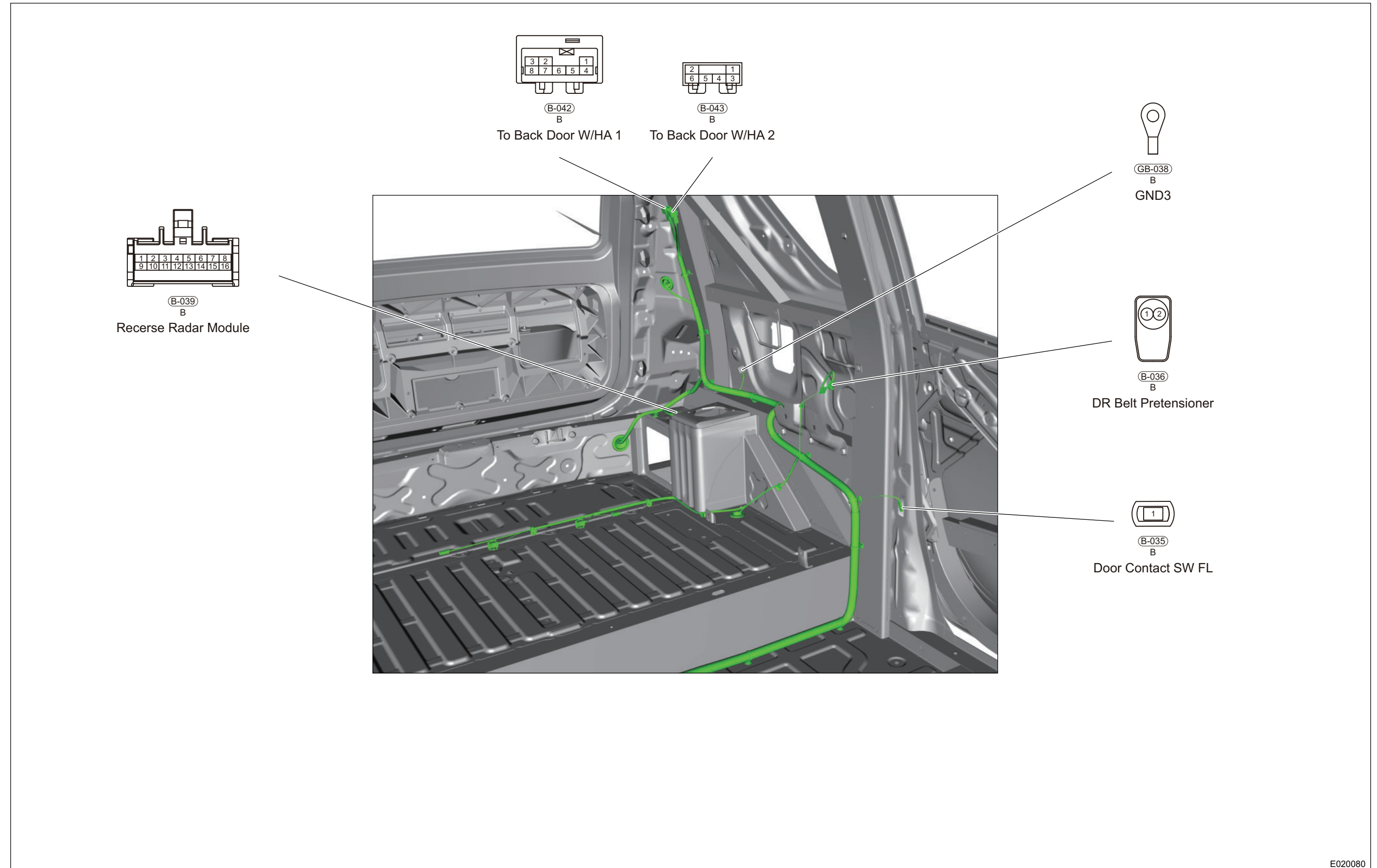

E020080

Interior Floor Wire Harness Connector Location Diagram (3/4)

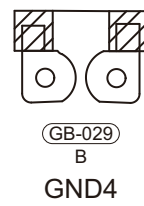
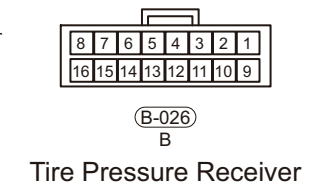
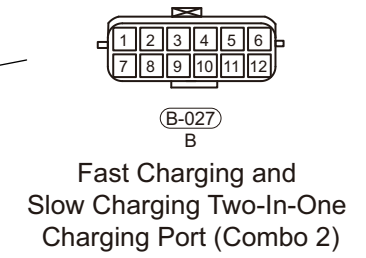
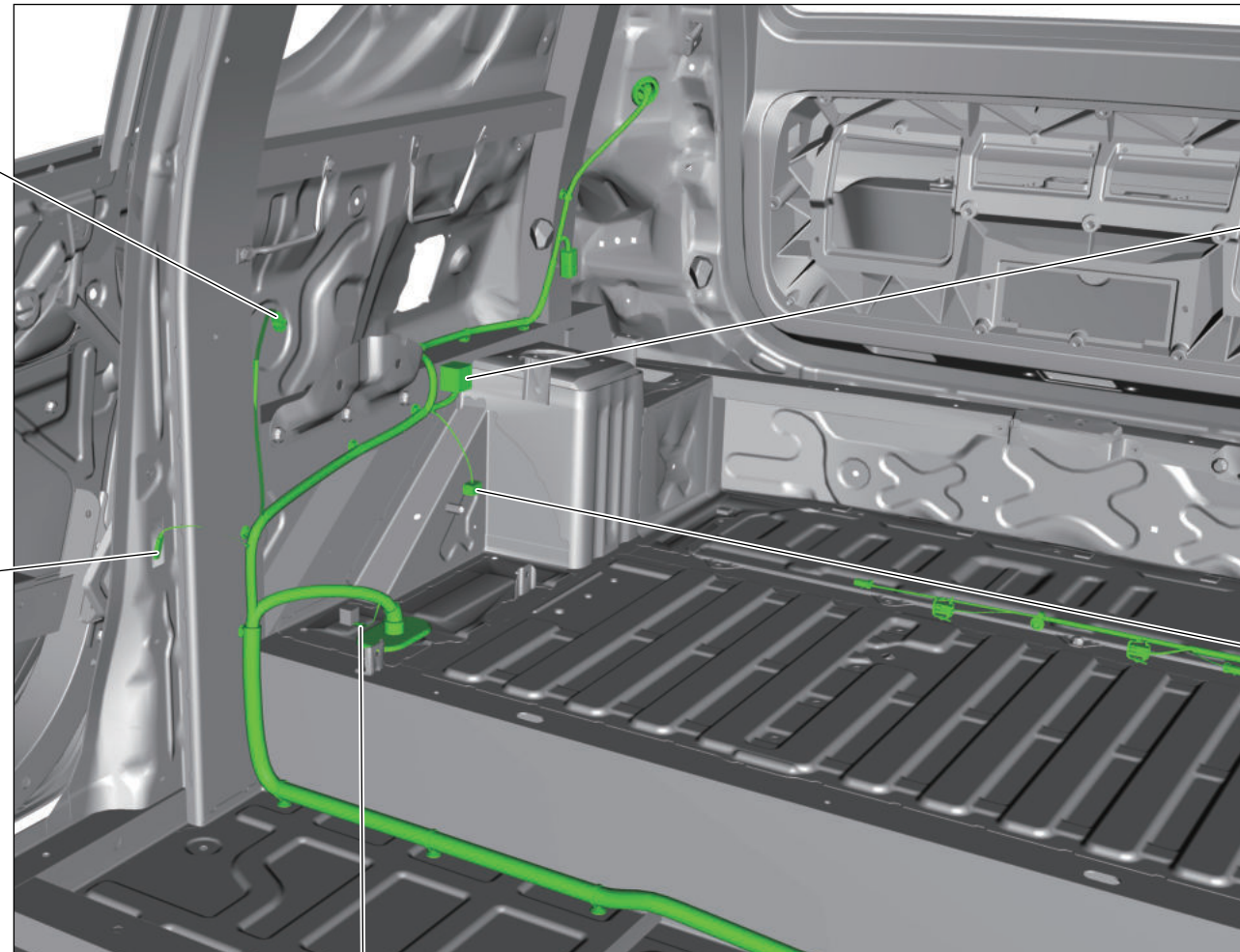
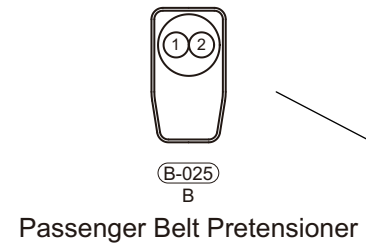

# Wire Harness Position Diagram

## Interior Floor Wire Harness Connector Location Diagram (4/4)

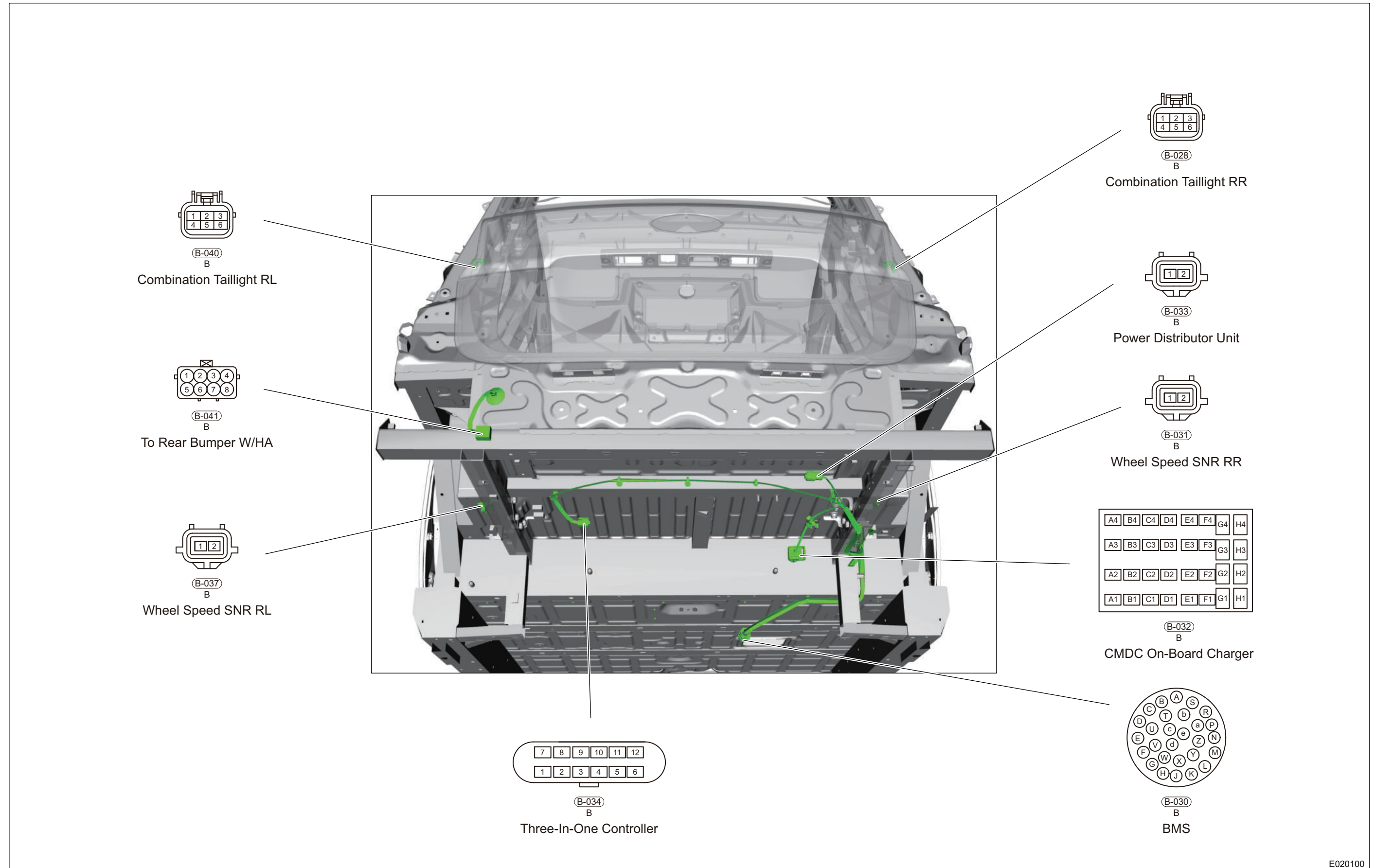



Left Door Wire Harness Connector Location Diagram

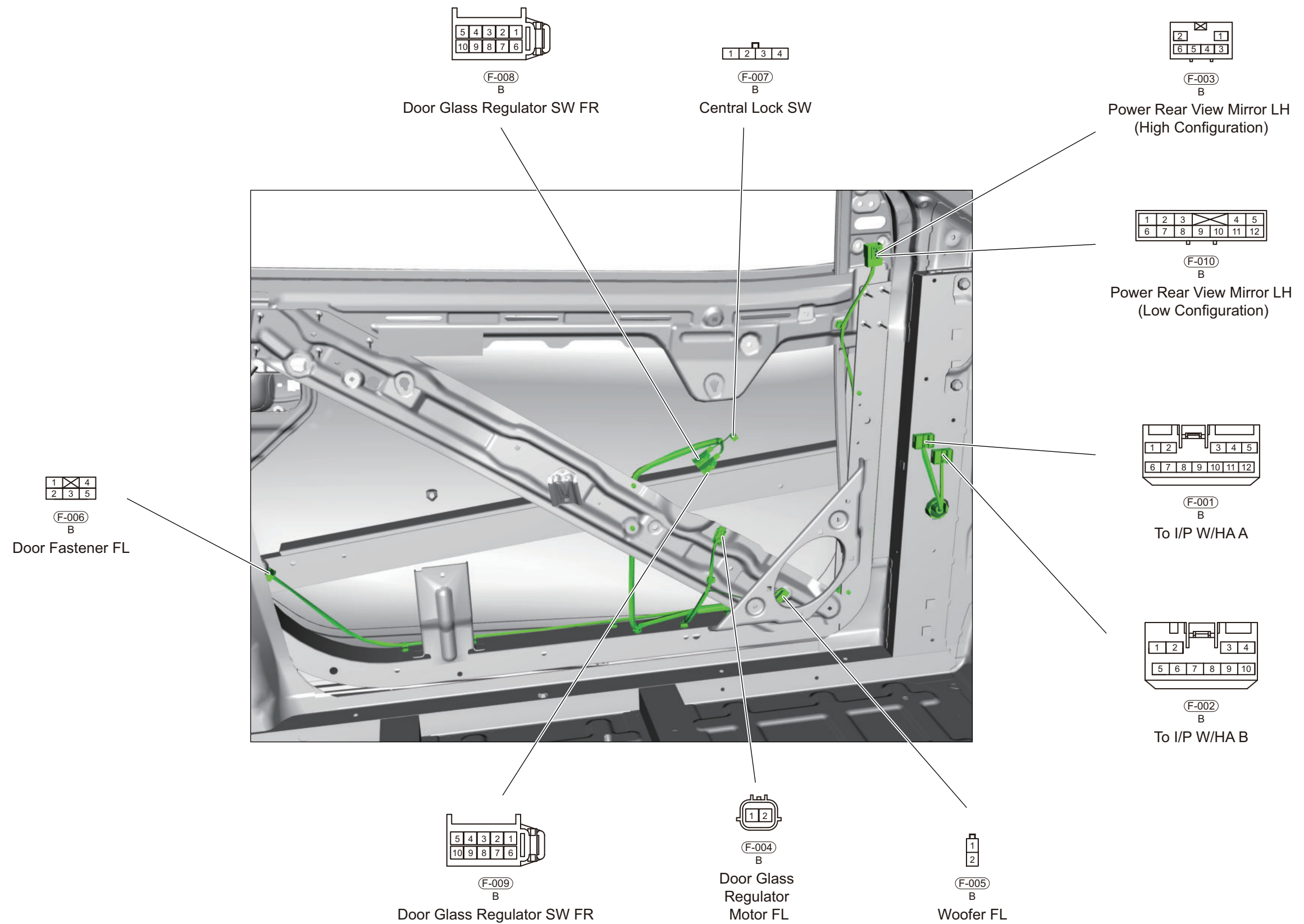

Right Door Wire Harness Connector Location Diagram

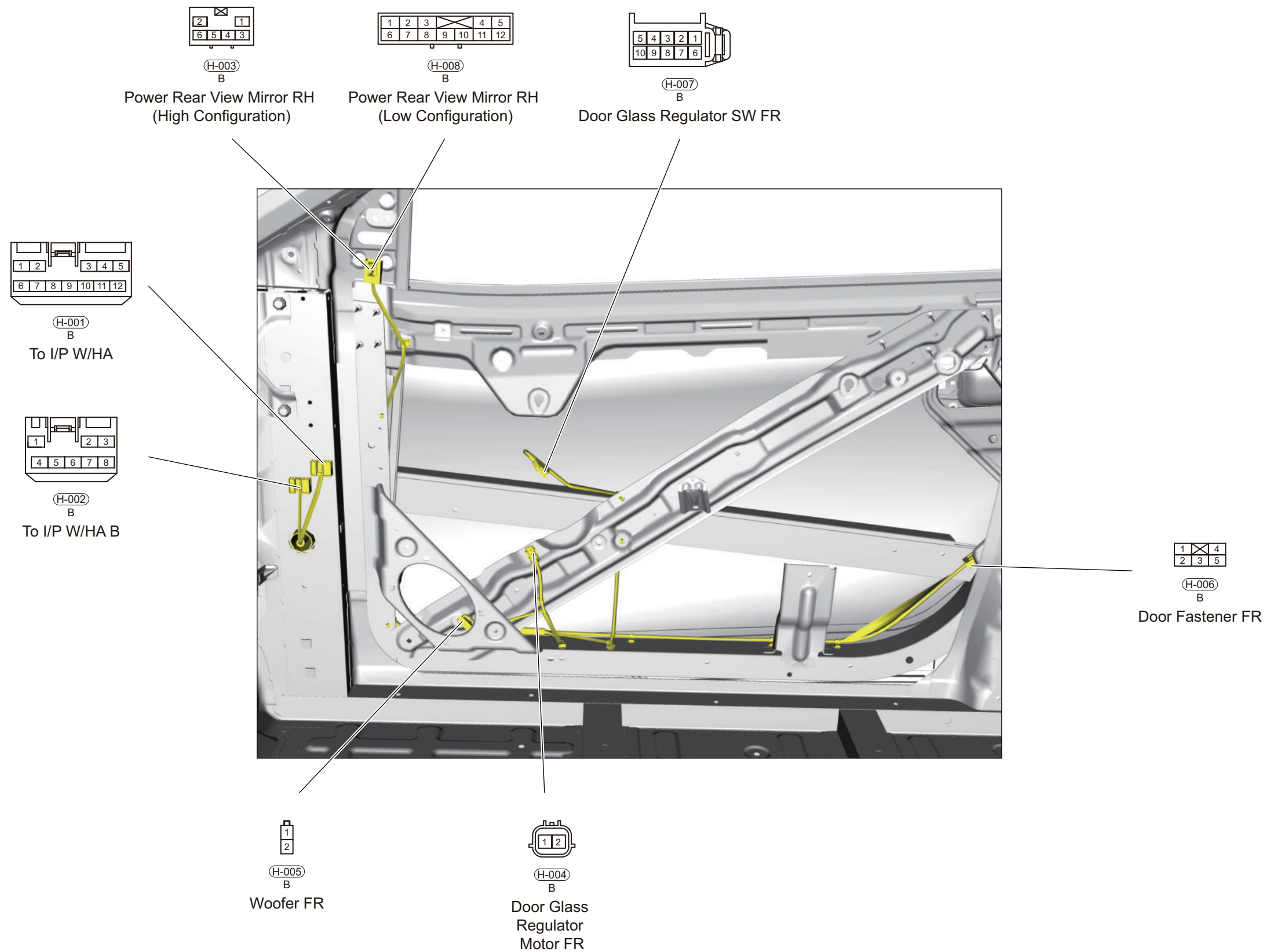



Back Door Wire Harness Connector Location Diagram

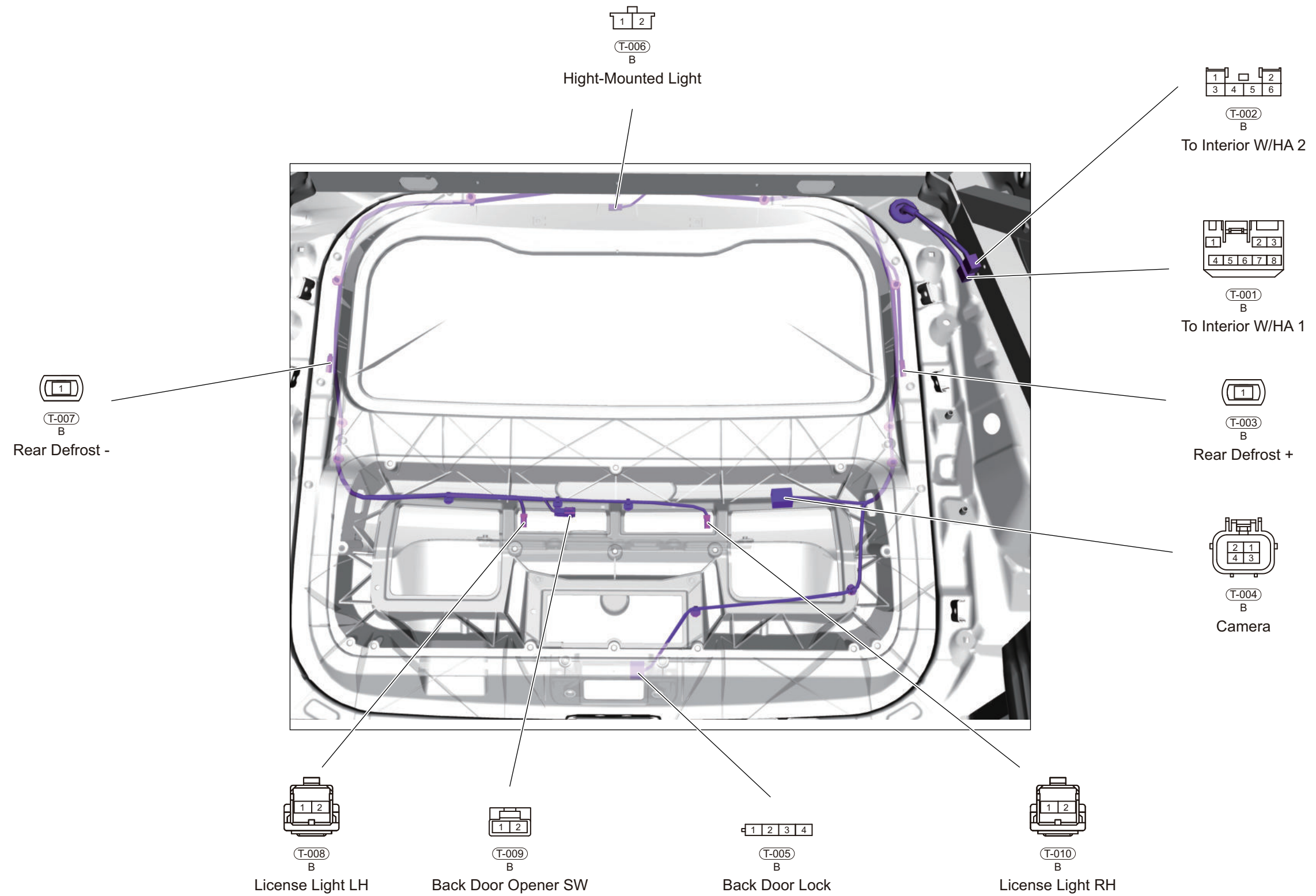

Rear Bumper Wire Harness Connector Location Diagram

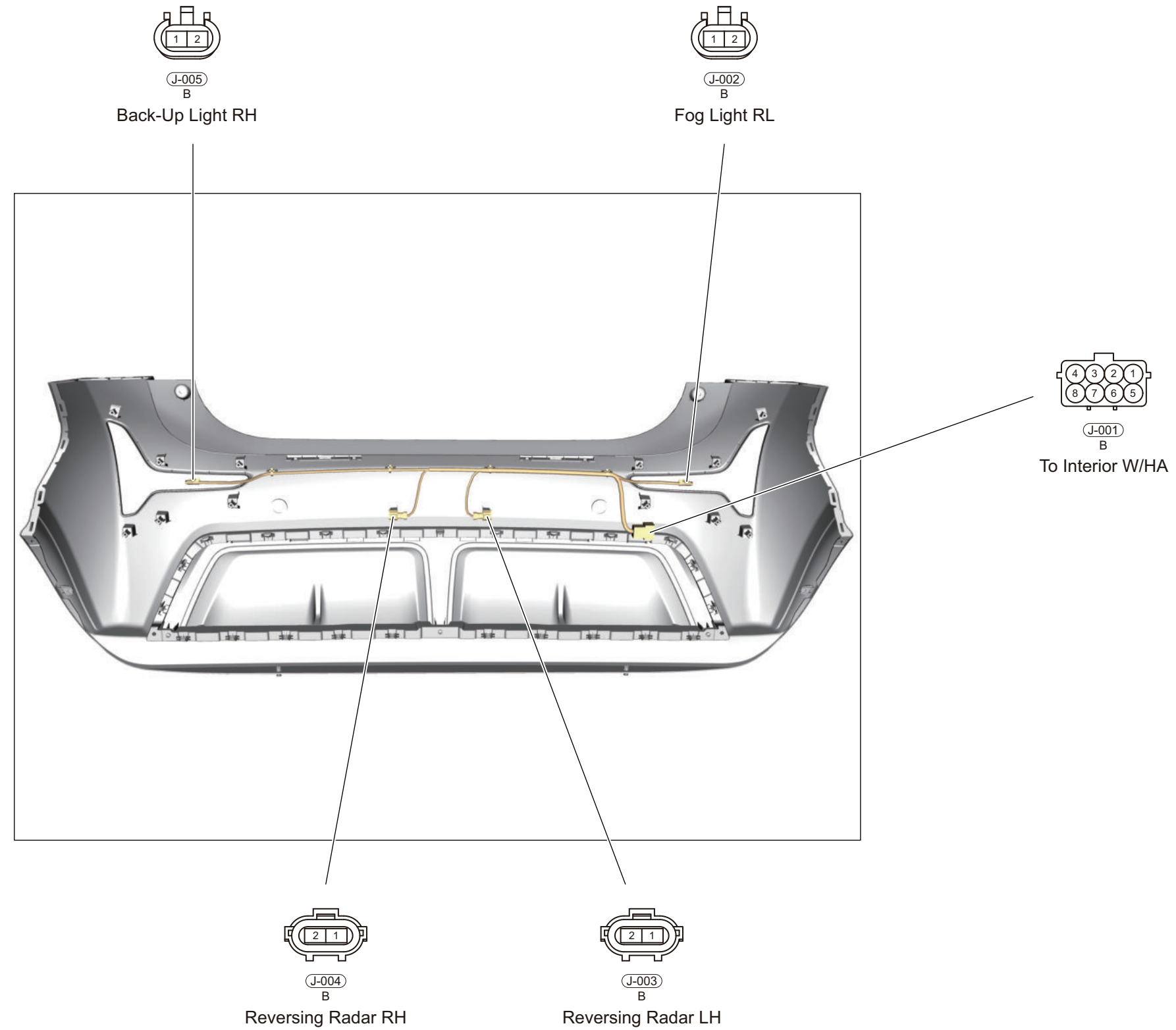

Position Diagram Of Battery Negative Wire Harness

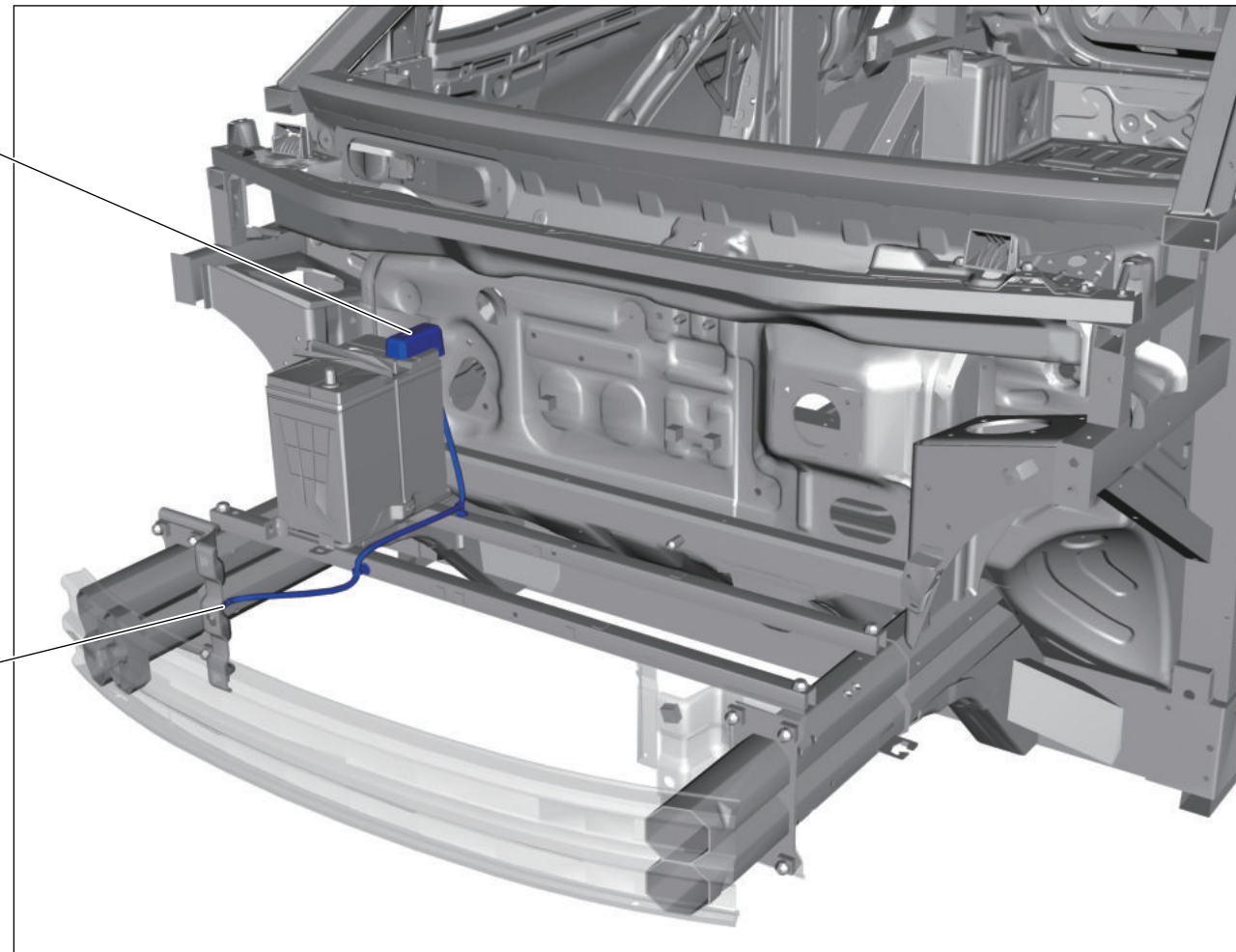
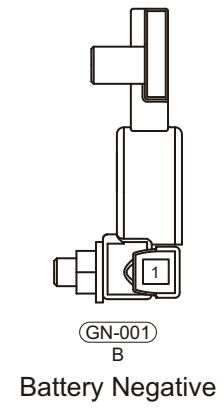

DCDC Ground

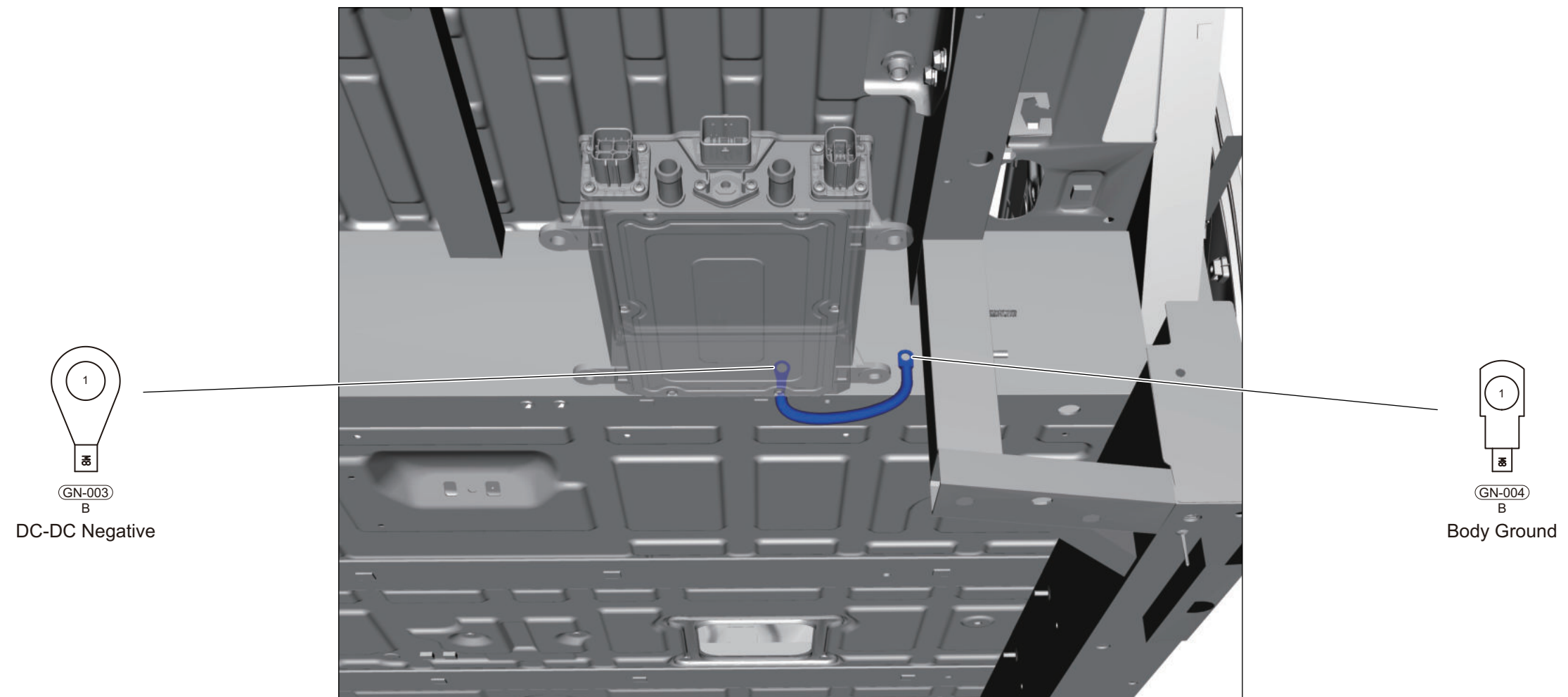



**DC+ Wire Harness Connector**

DC+ Wire Harness Connector (1/2)

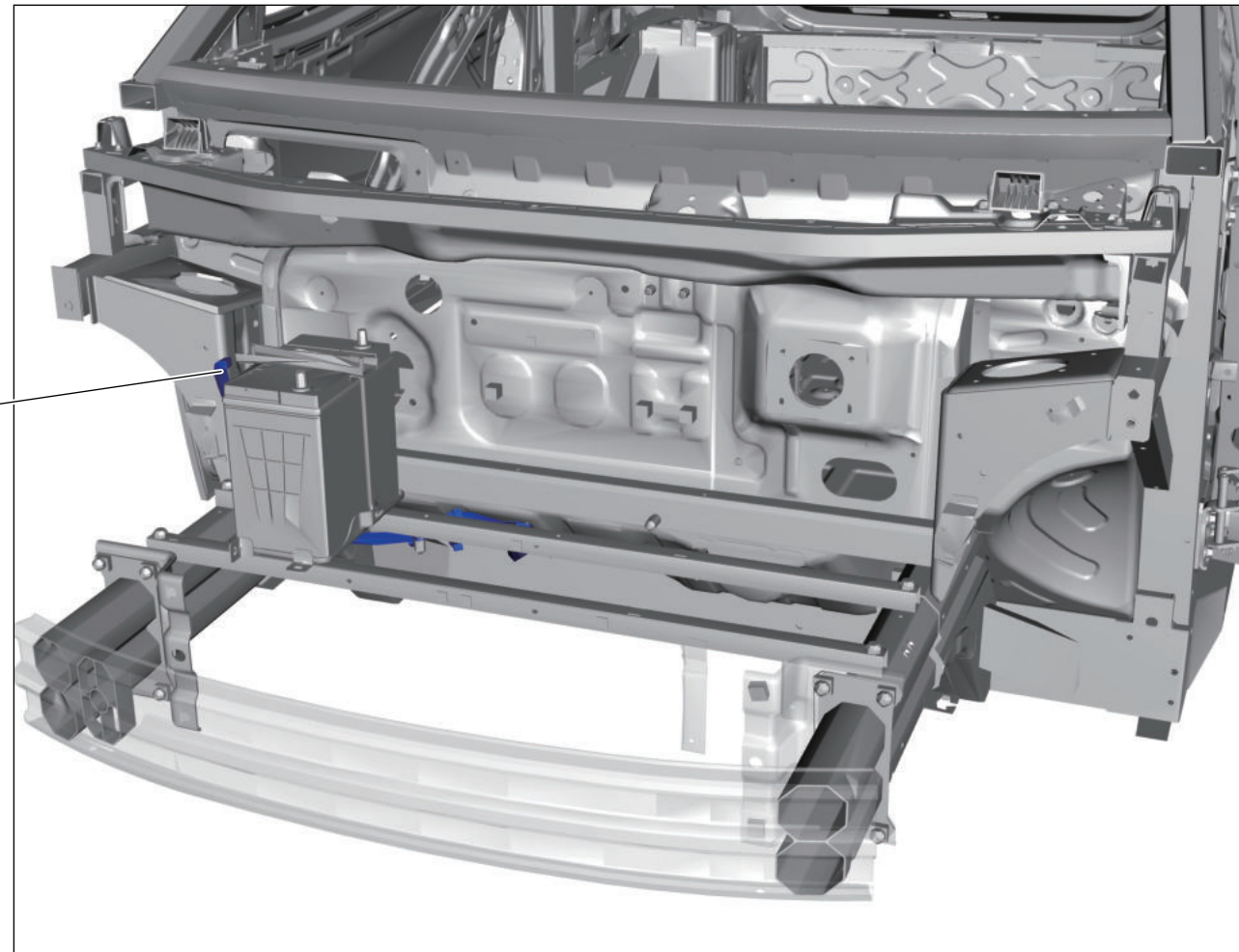
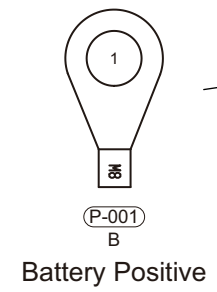

# Wire Harness Position Diagram

## DC+ Wire Harness Connector (2/2)

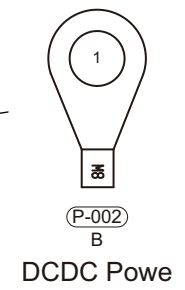
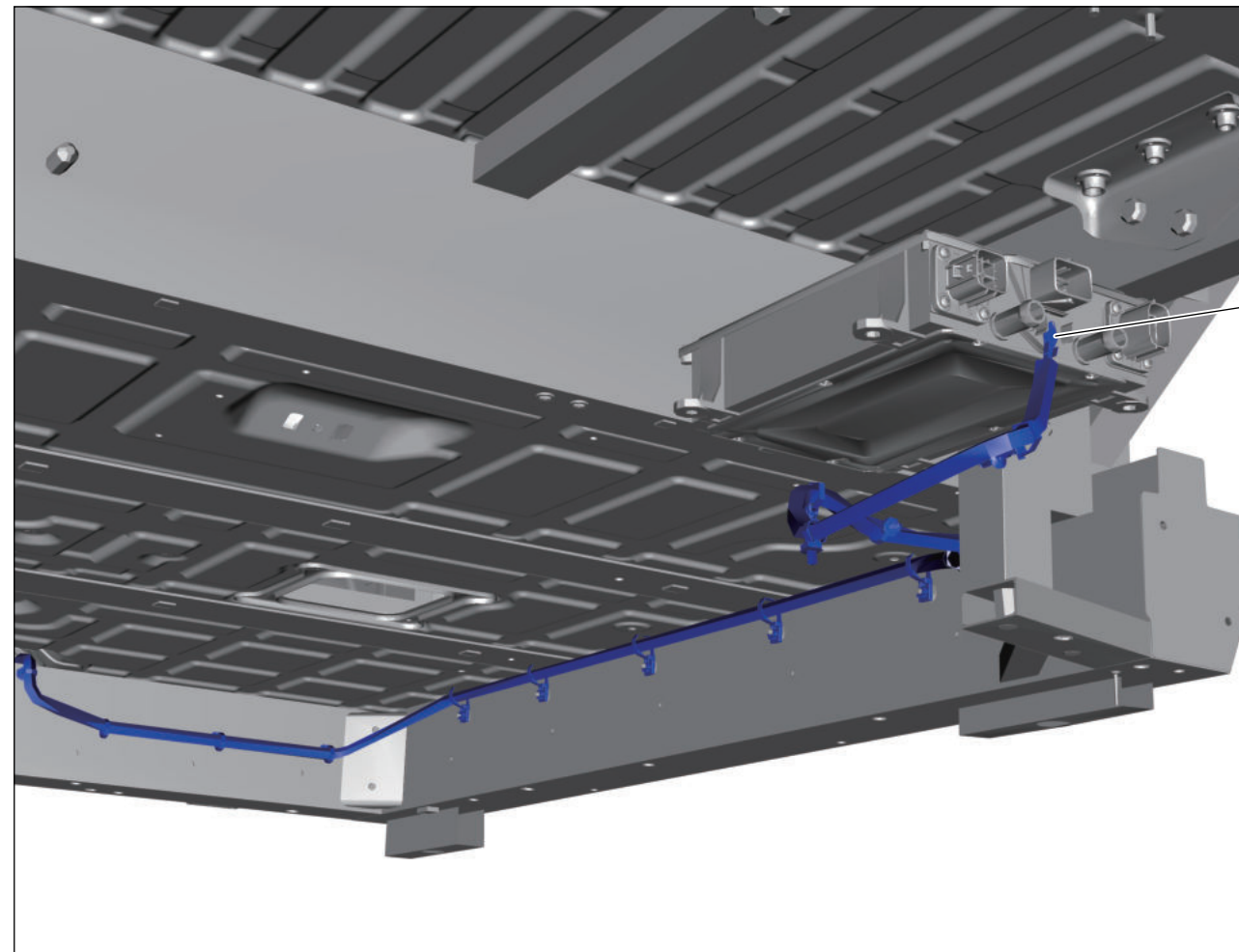



# System Circuit Diagram

## High Voltage Supply System

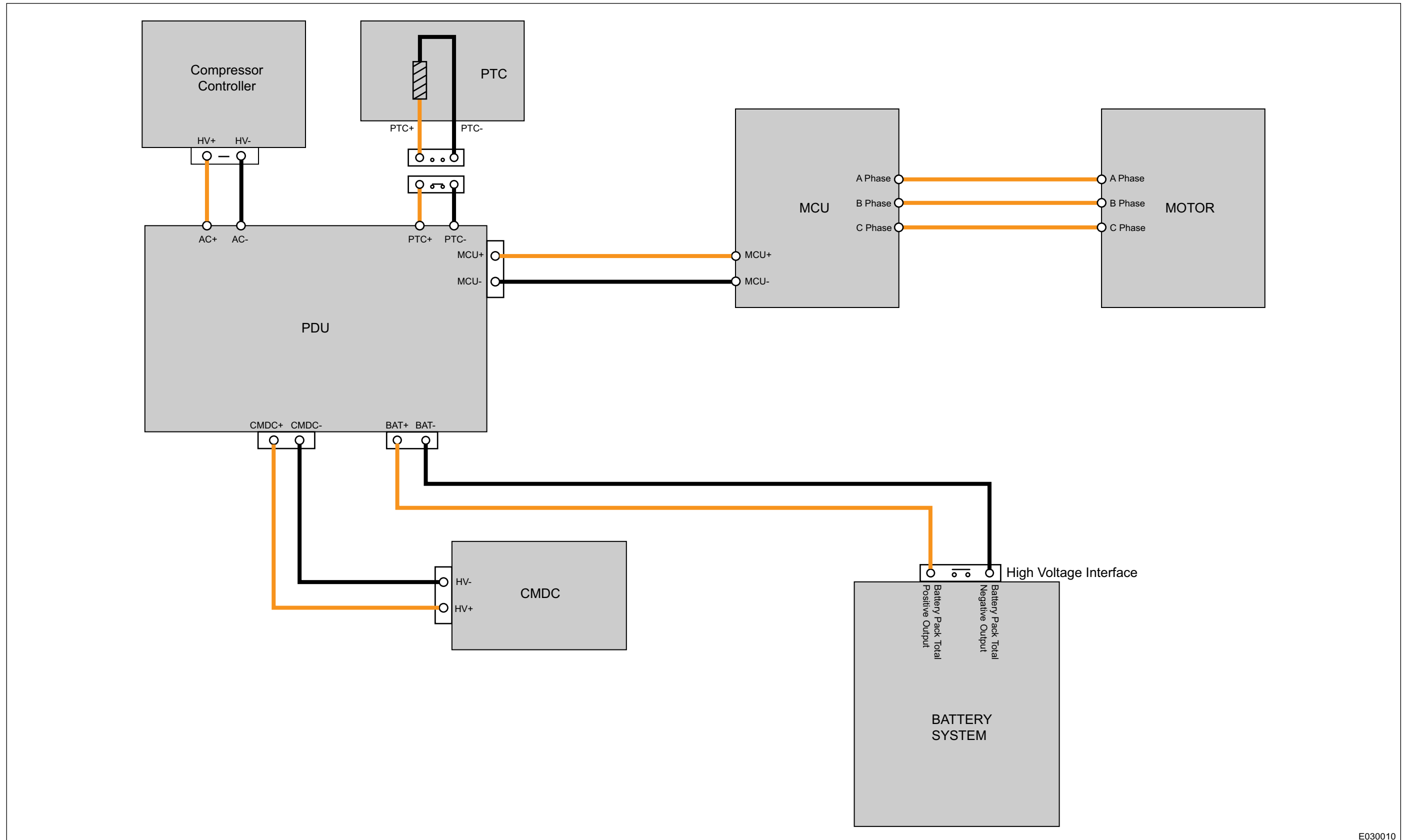

E030010

High Pressure Interlock

30(ENG)	30(ENG)
30(IP)	30(IP)
IGN	IGN
ACC	ACC

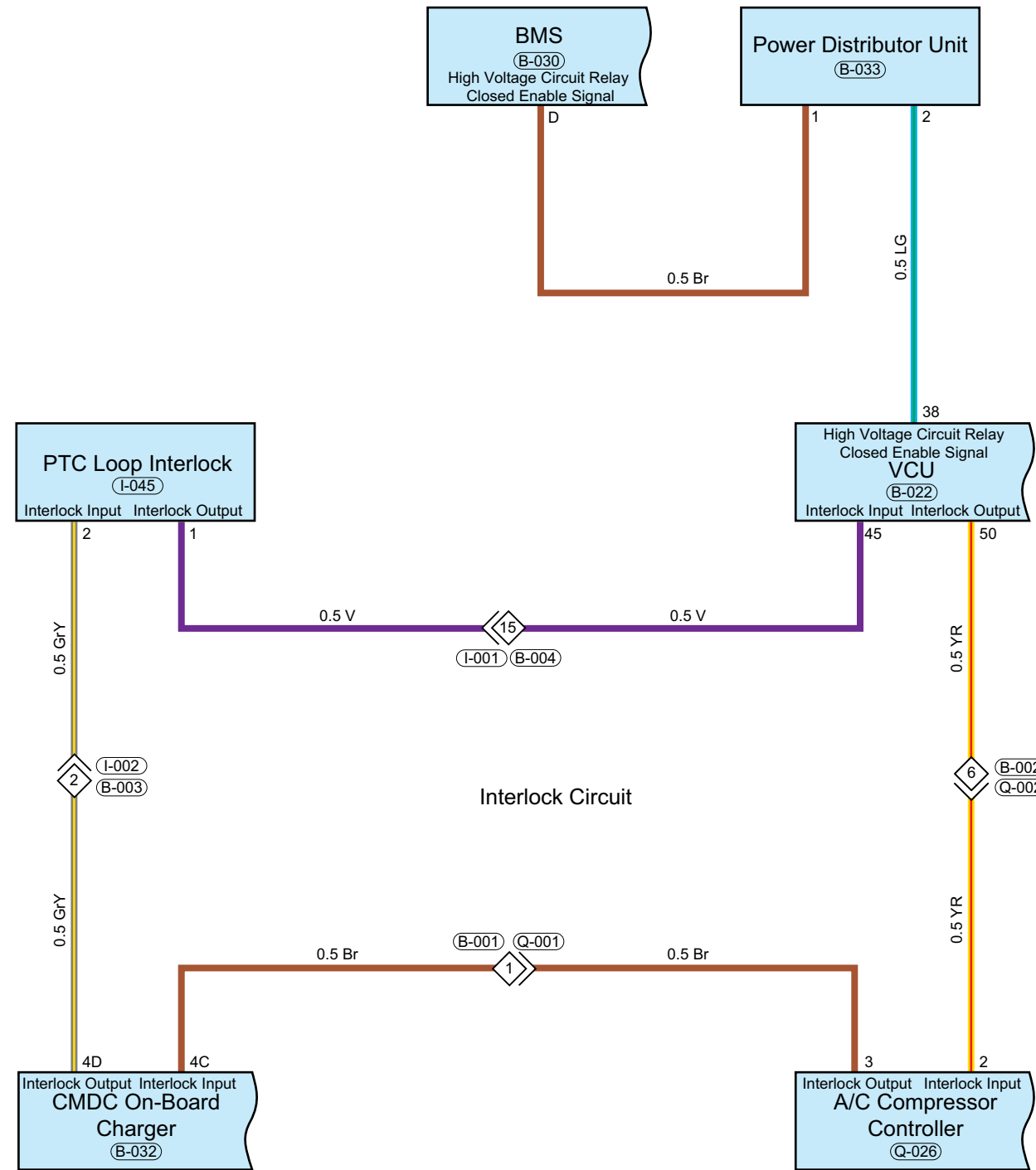

E030020

Battery and Vehicle Charger (DCDC)

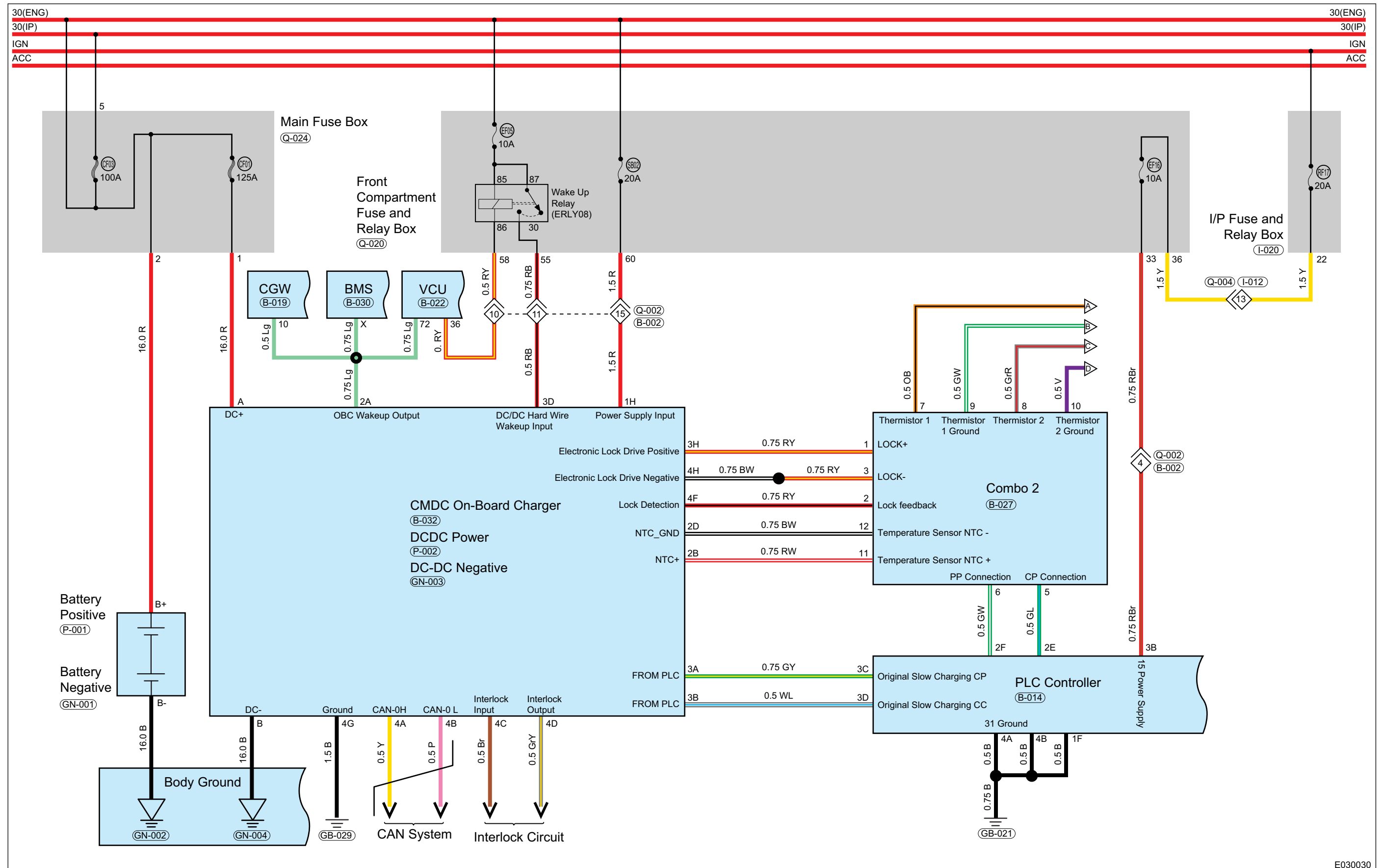

E030030

Battery Charging

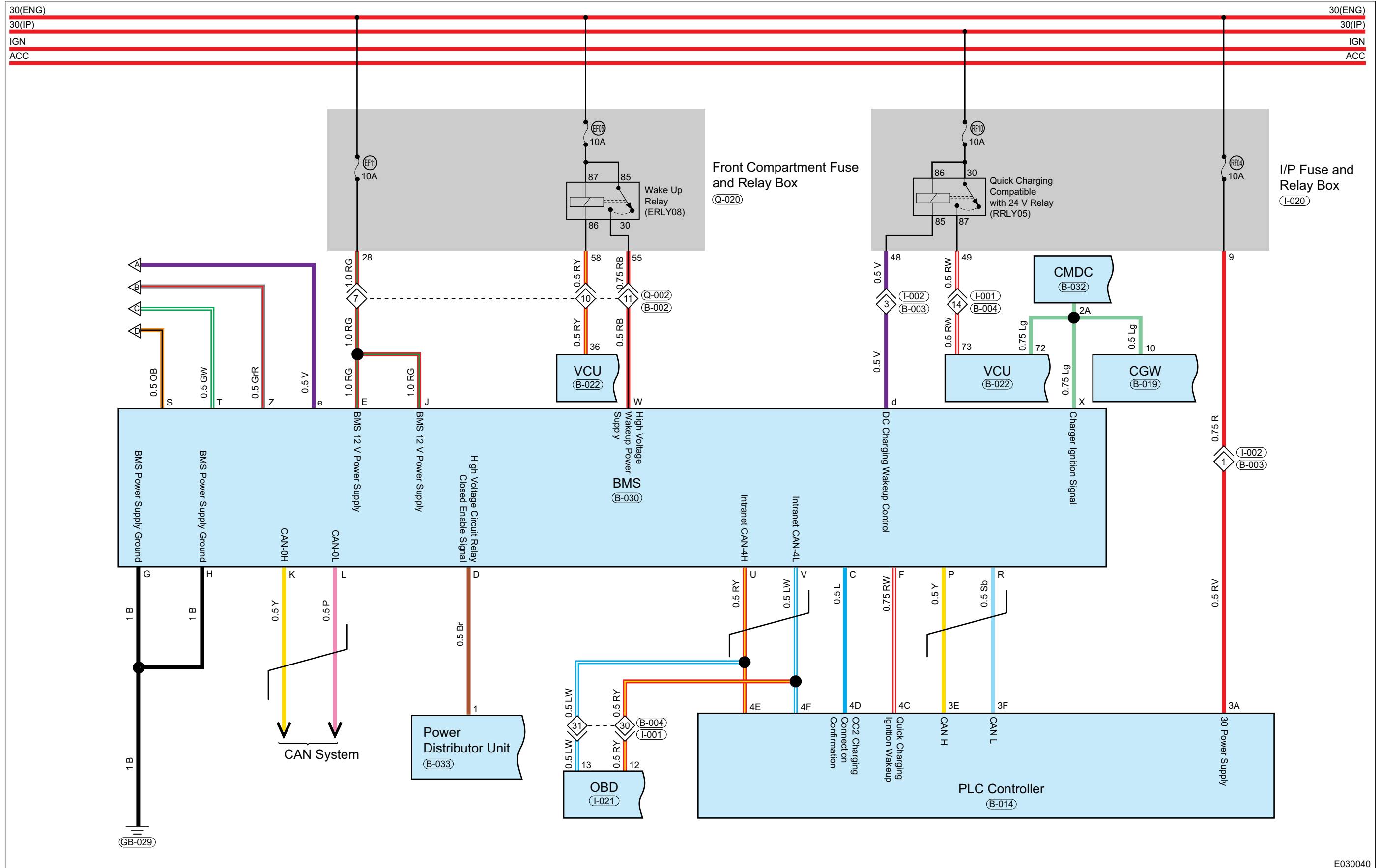

E030040

**BCM**  
BCM Plug-in Terminal Description

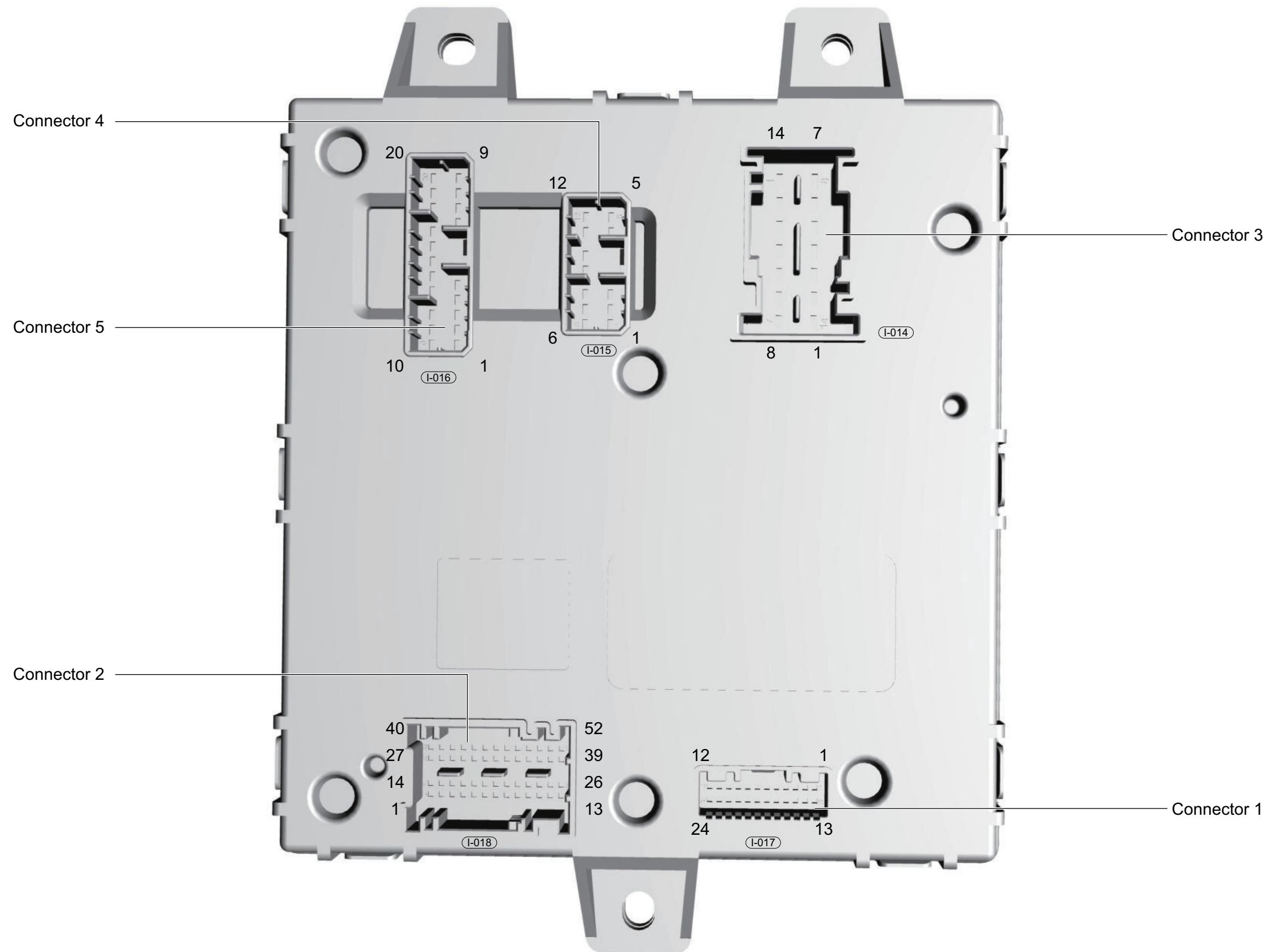



# System Circuit Diagram

## BCM Power Supply, Network Communication

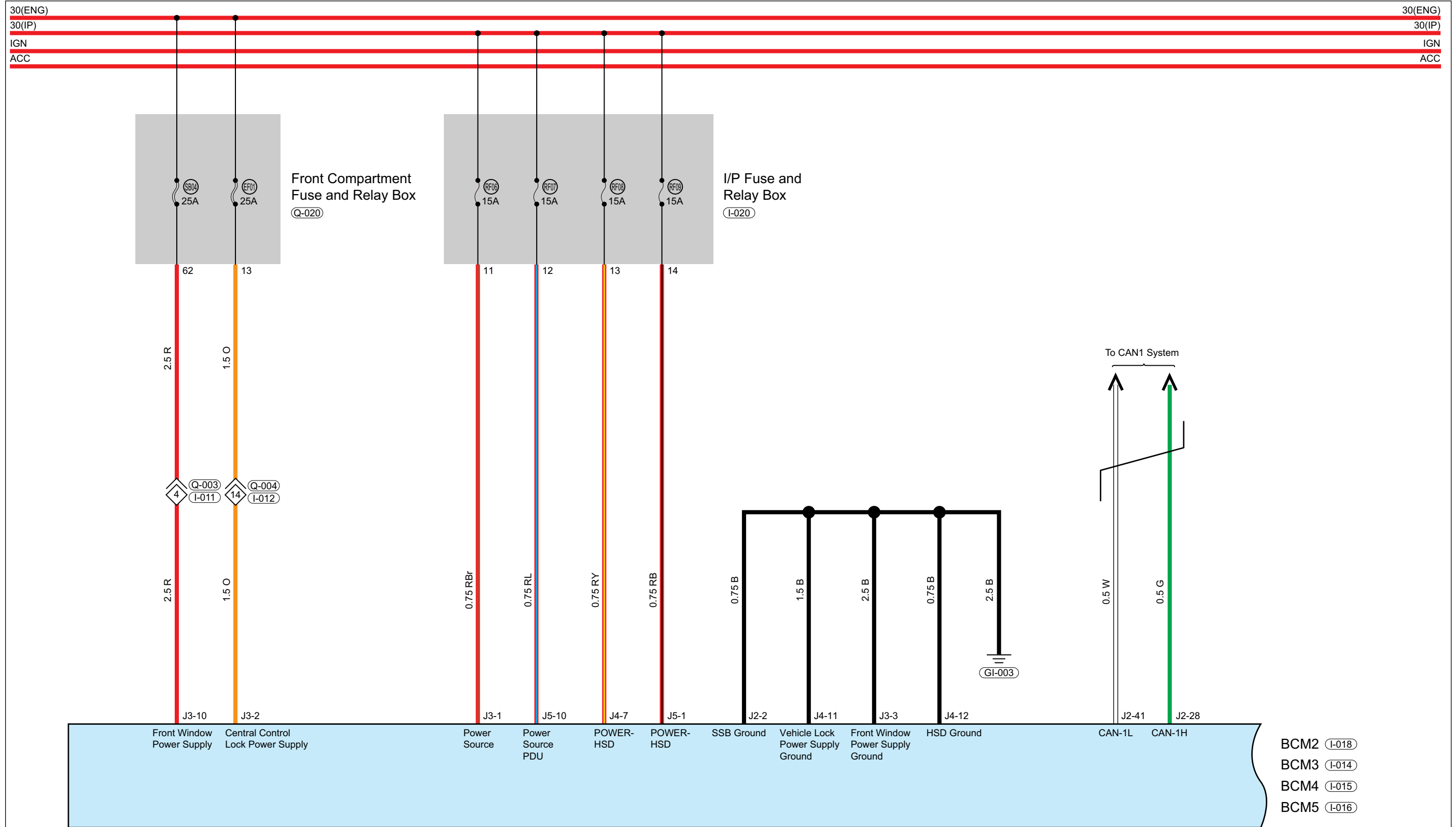

E030060

Start Switch

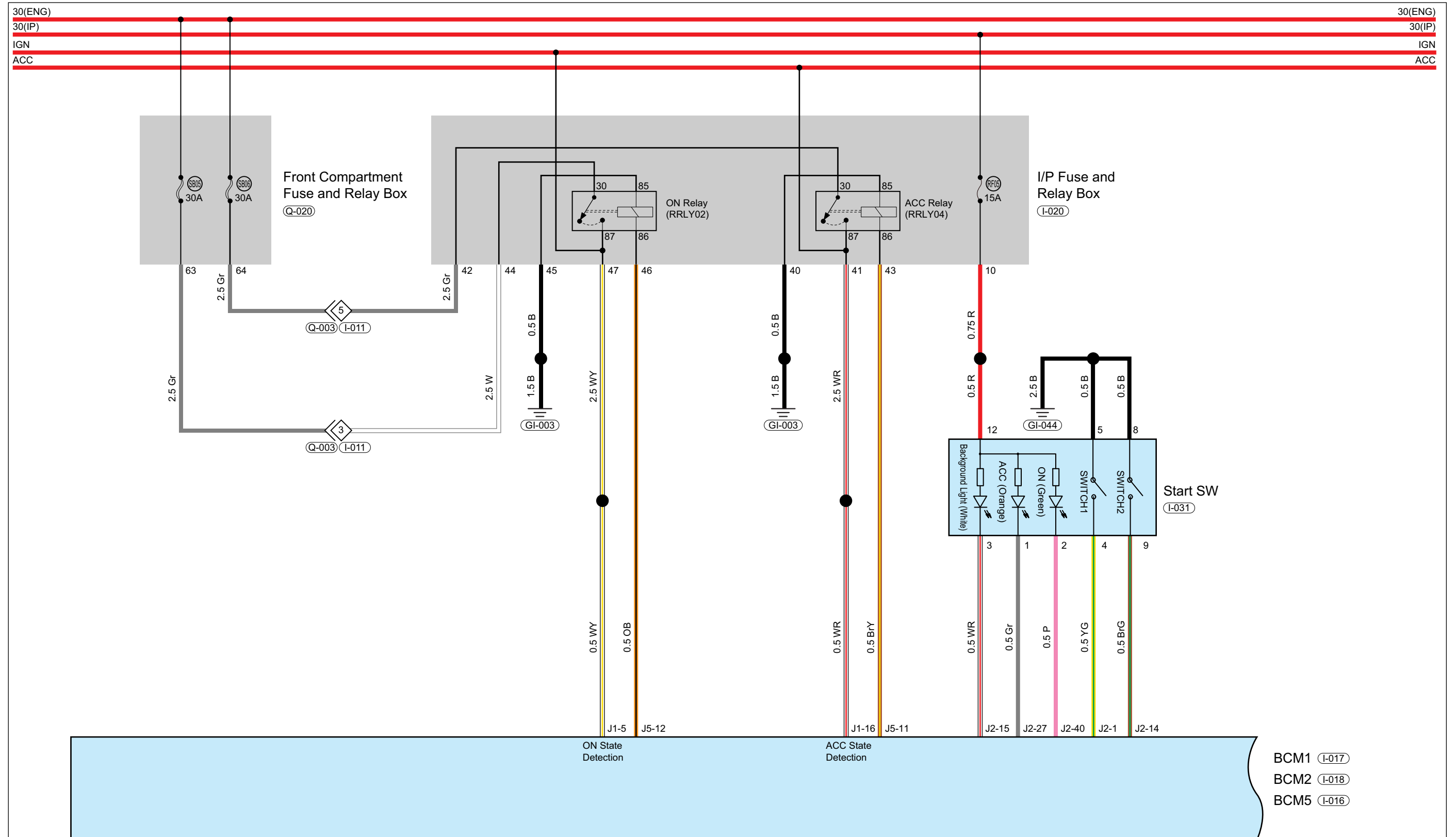

E030070

# System Circuit Diagram

## Back Light

30(ENG)	30(ENG)
30(IP)	30(IP)
IGN	IGN
ACC	ACC

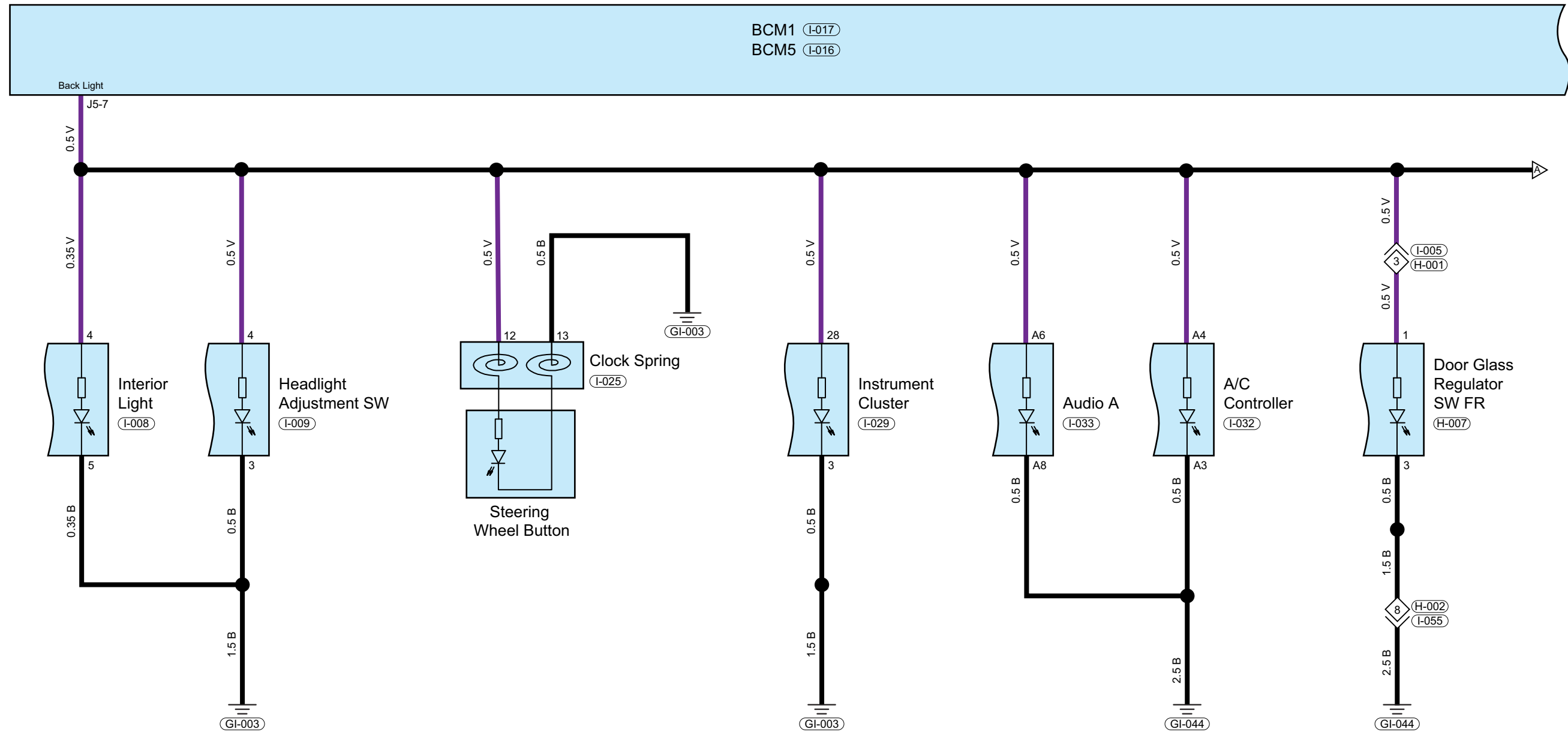

E030080

Back Light, Front Position Light

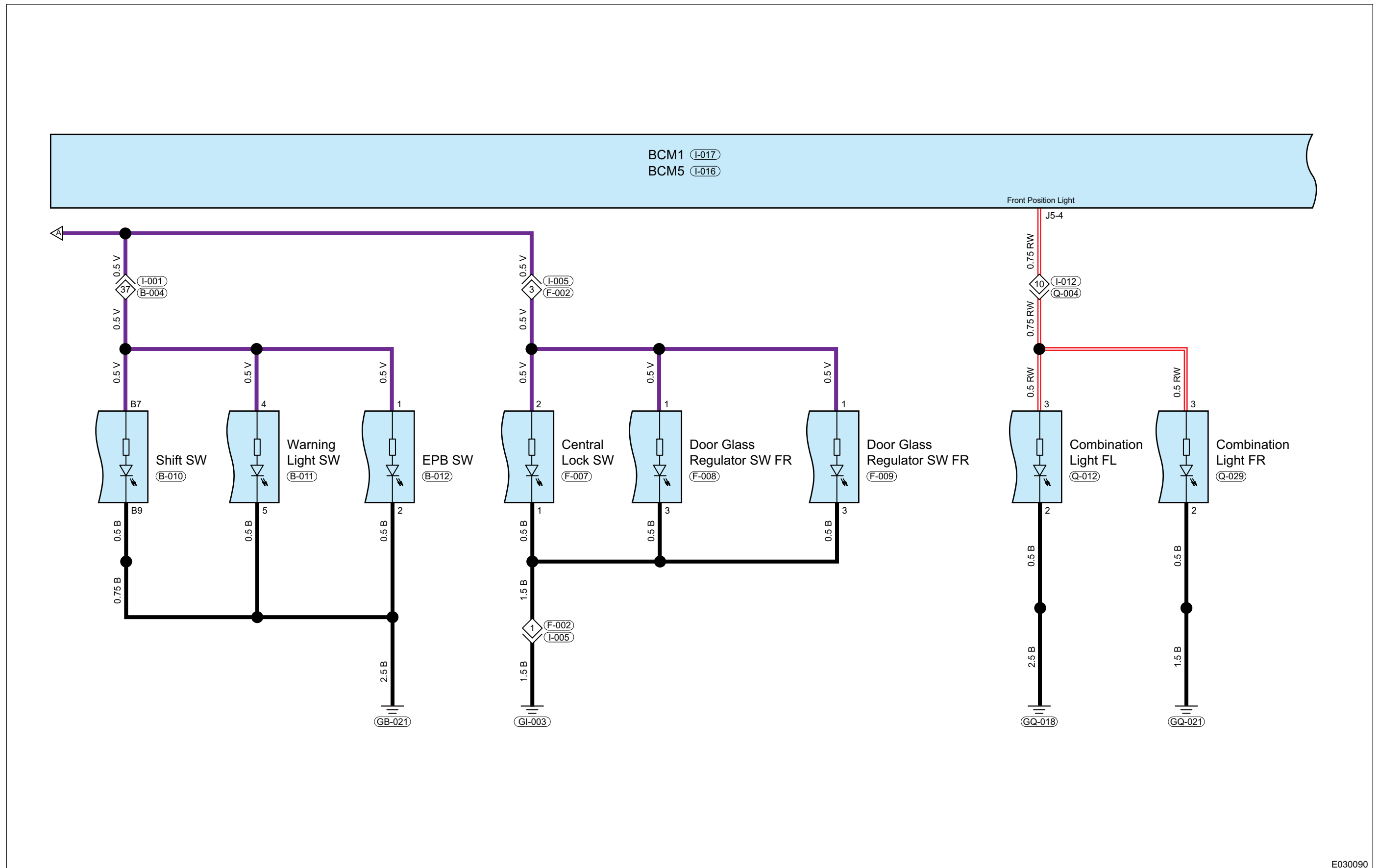

E030090

# System Circuit Diagram

## Rear Position Light, License Plate Light, Day Running Light, Reverse Light

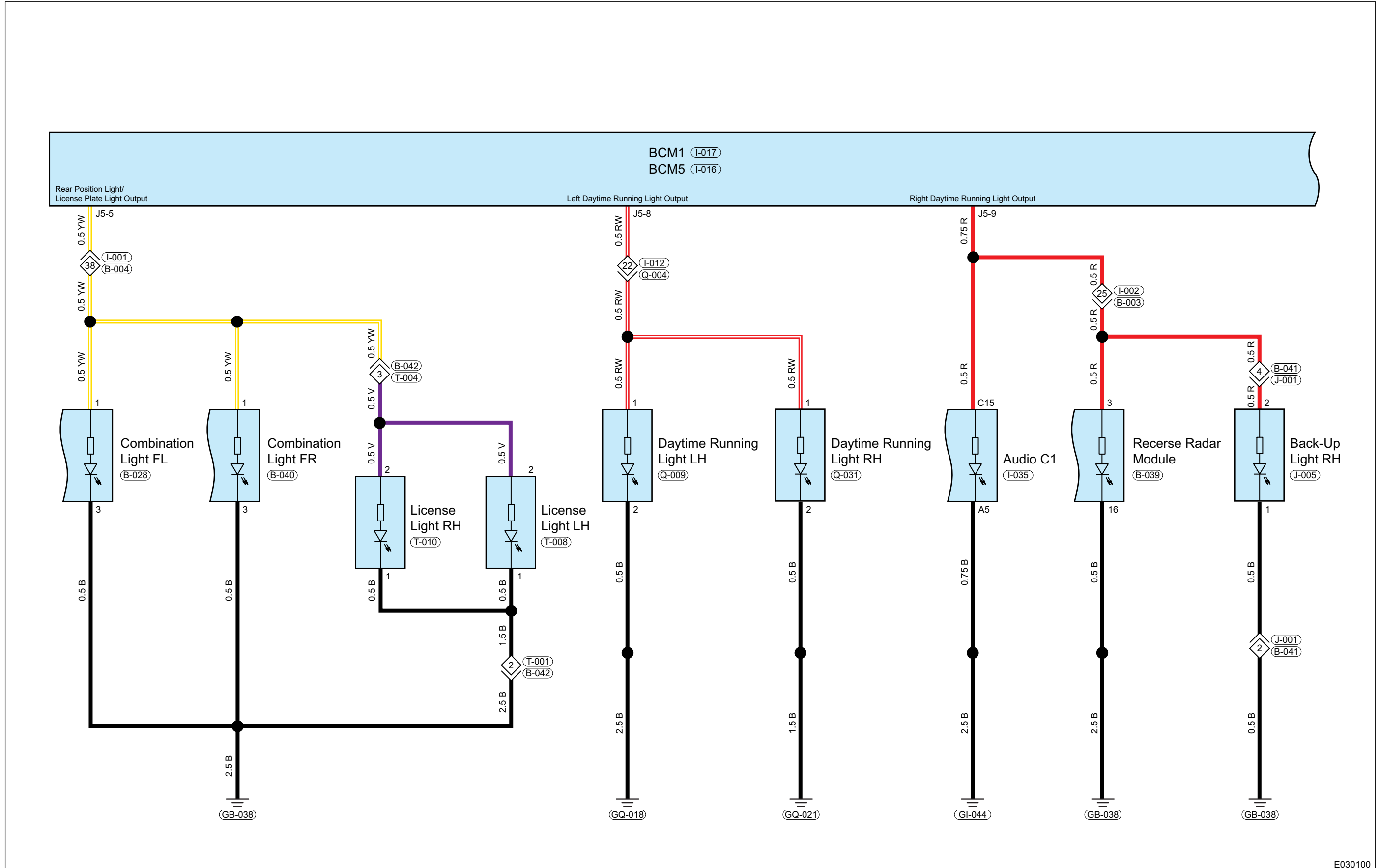

E030100



Turn Signal, Hazard Signal

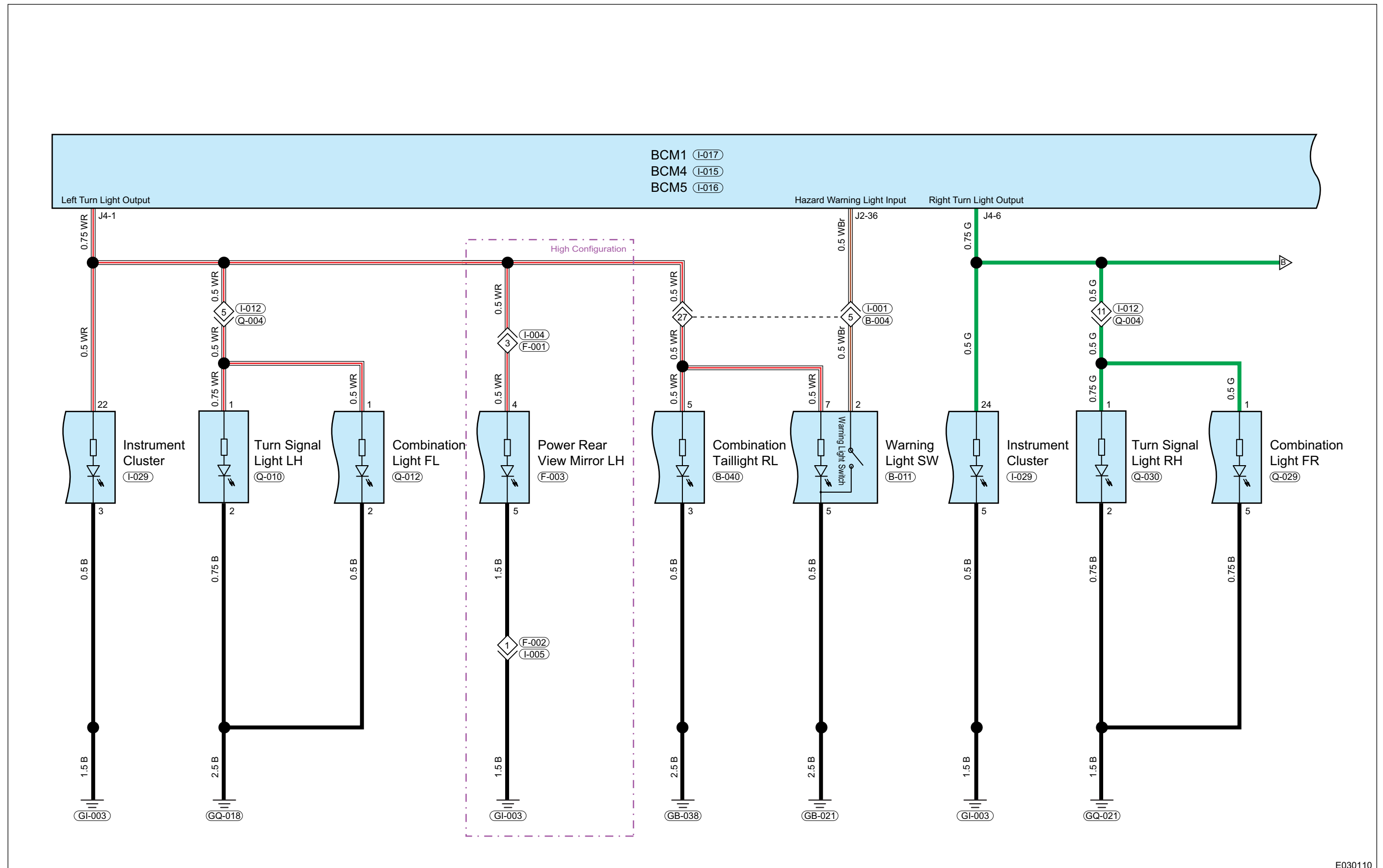

E030110

# System Circuit Diagram

## Brake Light, Security LED, Rear Fog Light Output

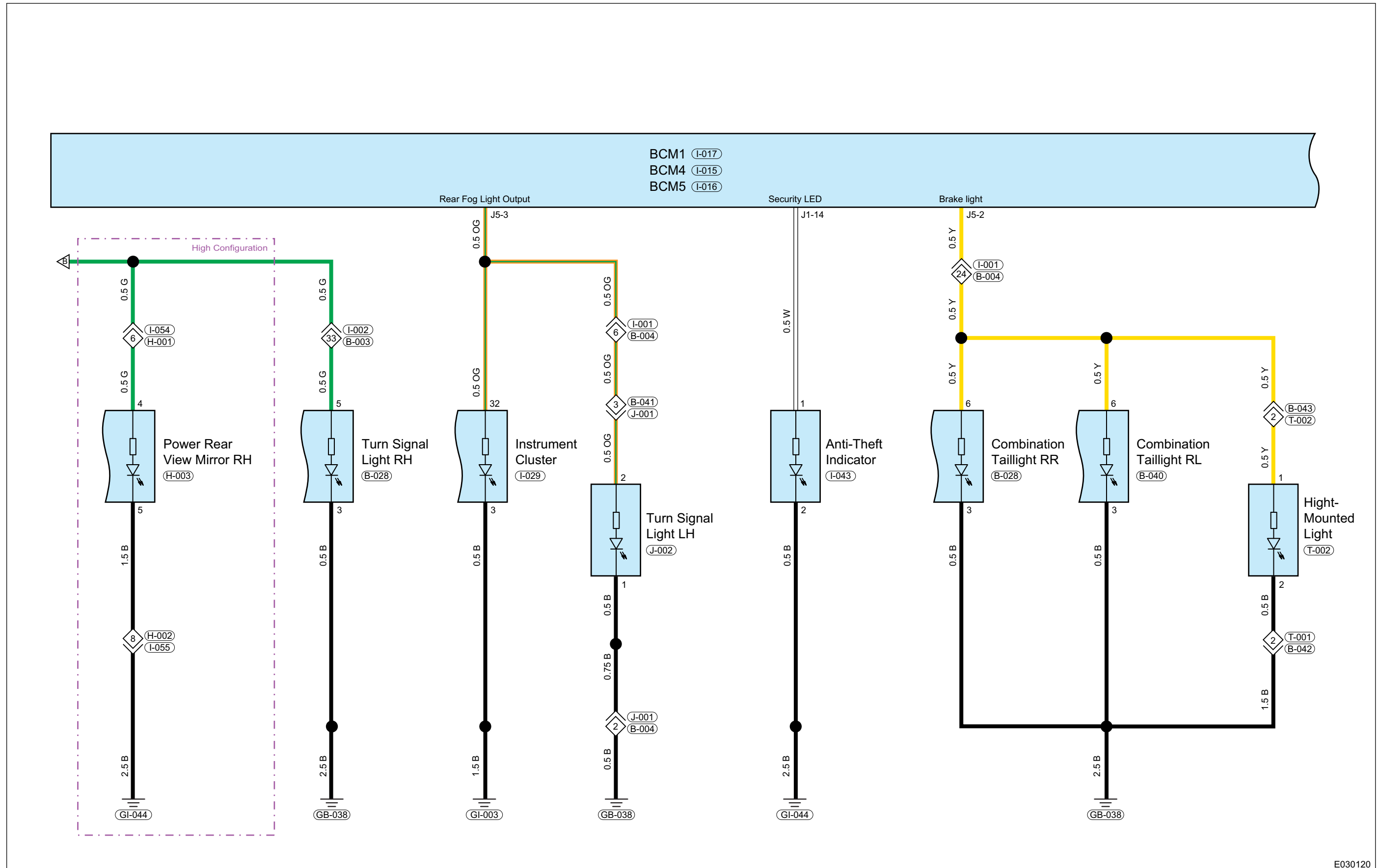

E030120

Light Control (Combination) SW, Wiper SW, BCM

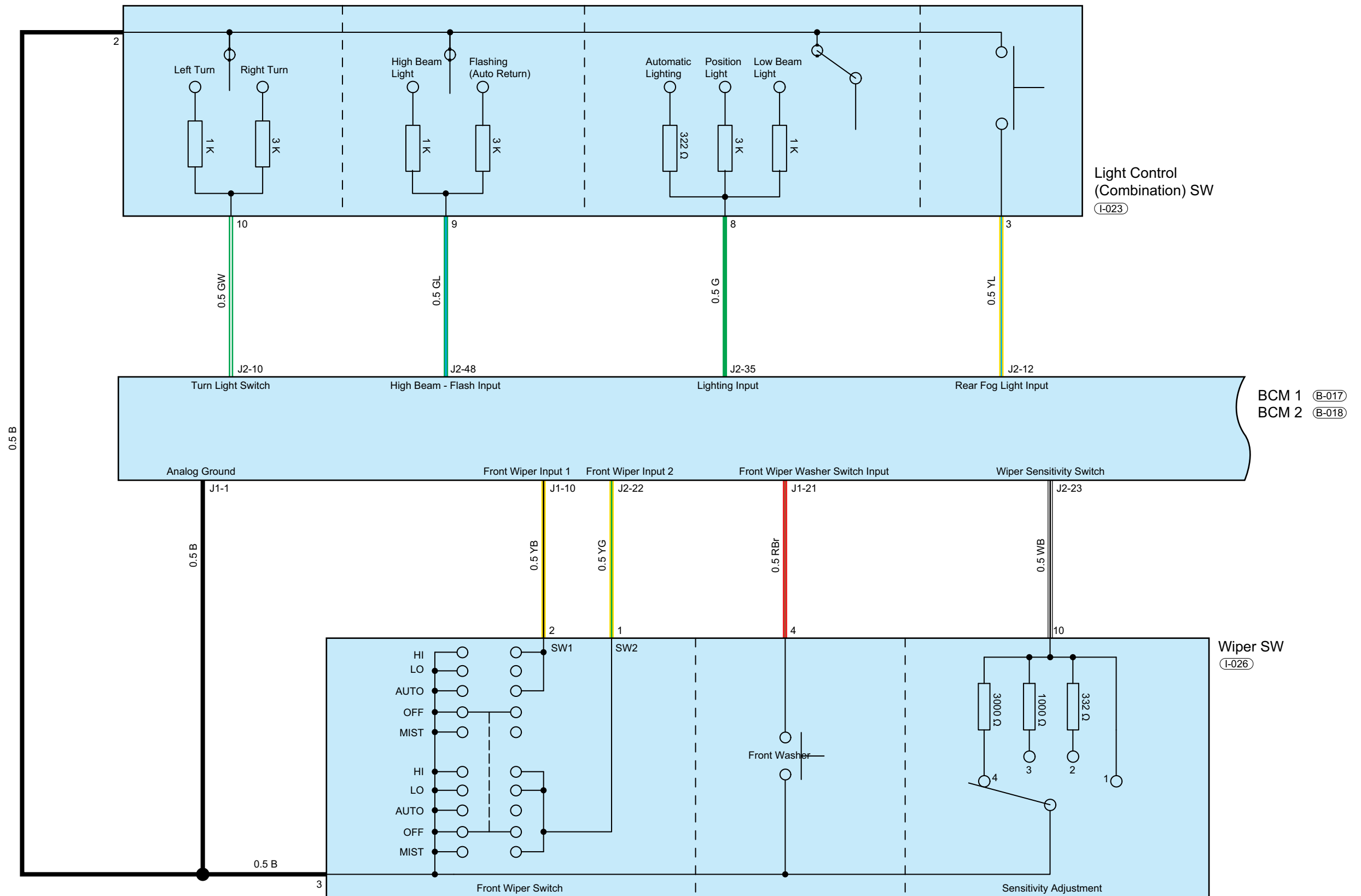

E030130

# System Circuit Diagram

## Combination Light, Headlight Adjustment SW

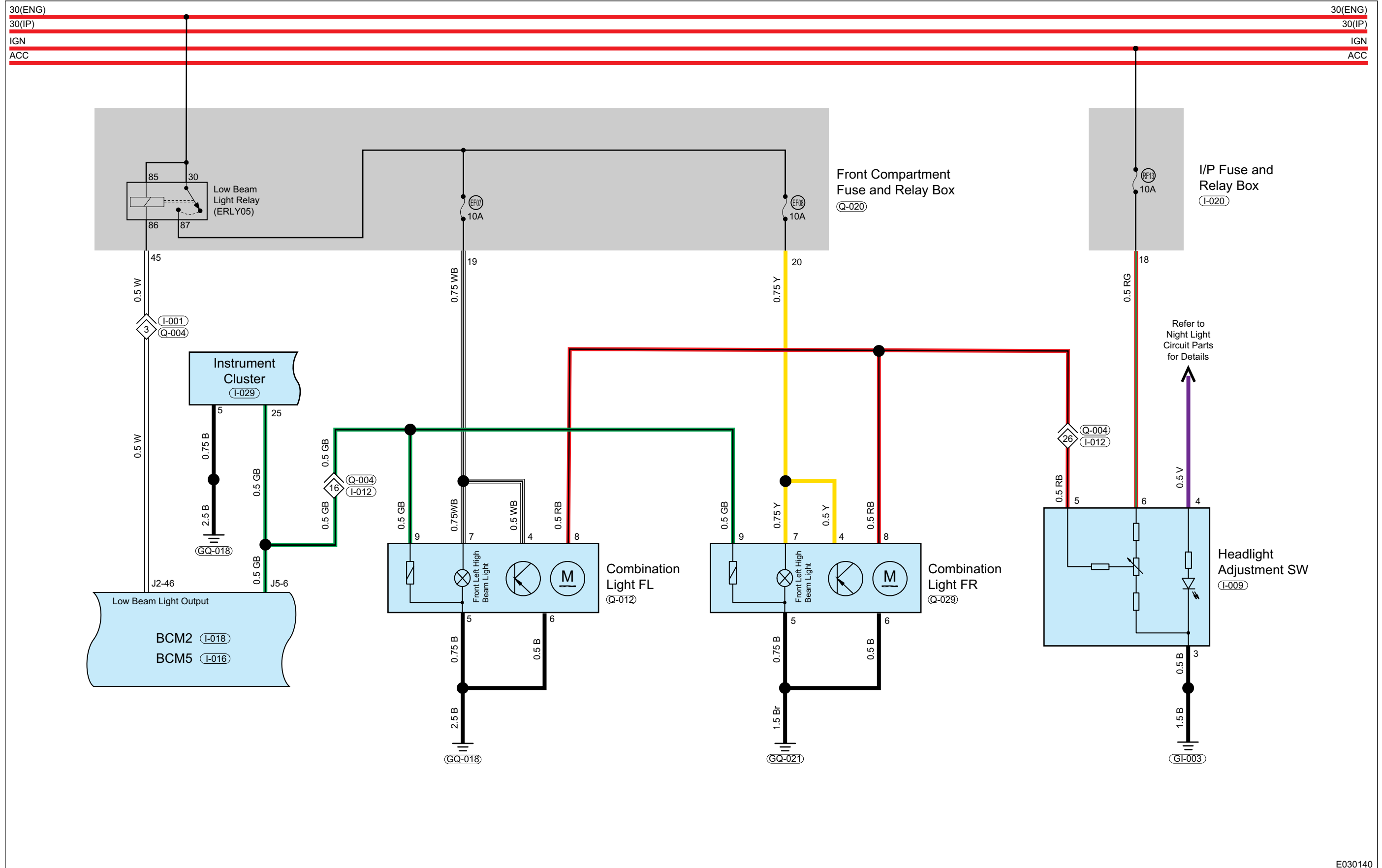

E030140



BCM, Interior Light, Horn, Anti-Theft Horn, Horn, Door Glass Regulator Motor FR, Door Glass Regulator Motor FL

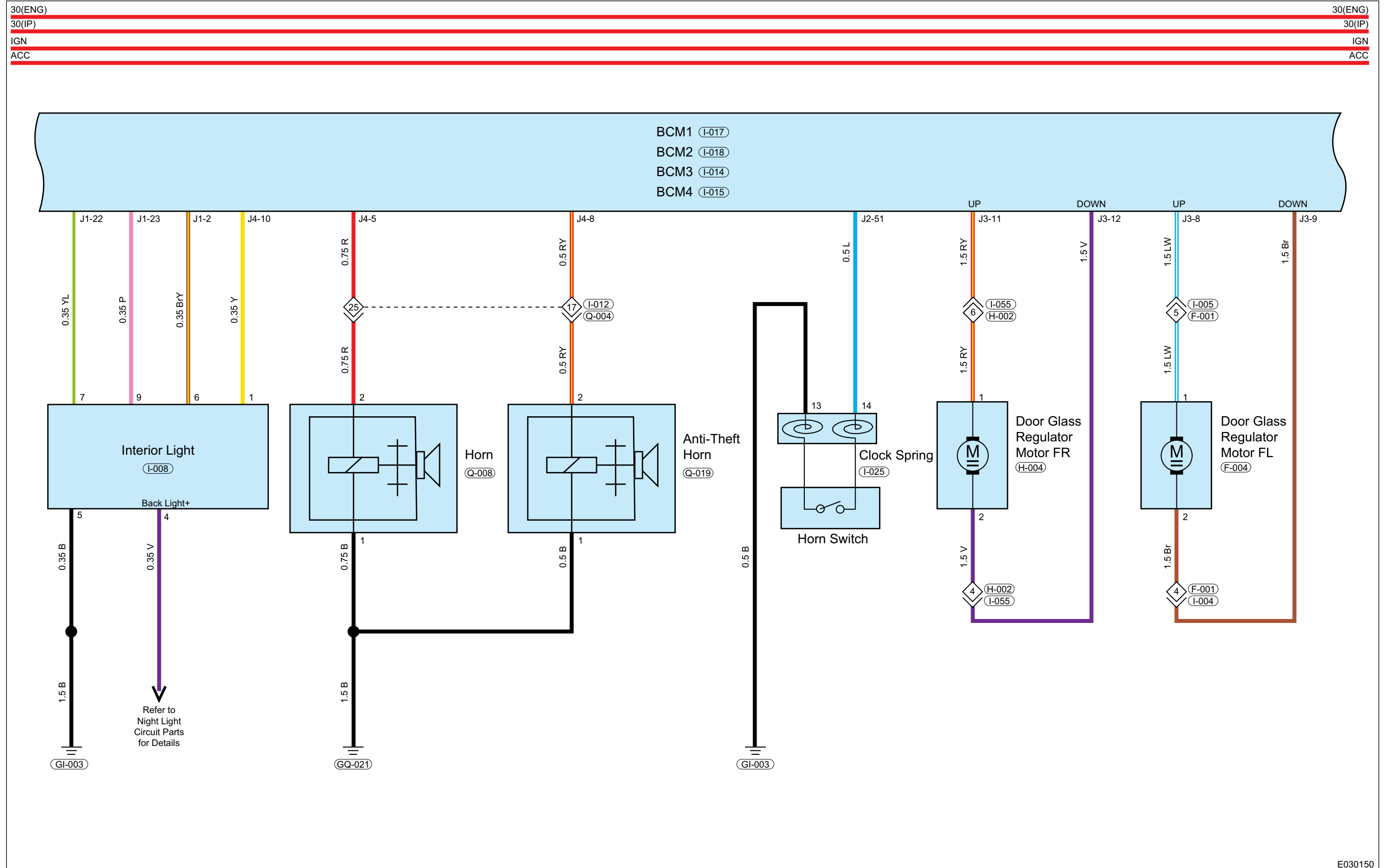

E030150

# System Circuit Diagram

## BCM, Front Wiper Motor, Low Frequency Antenna, Anti-Theft Coil, Front Washer Pump Motor, Light SNR

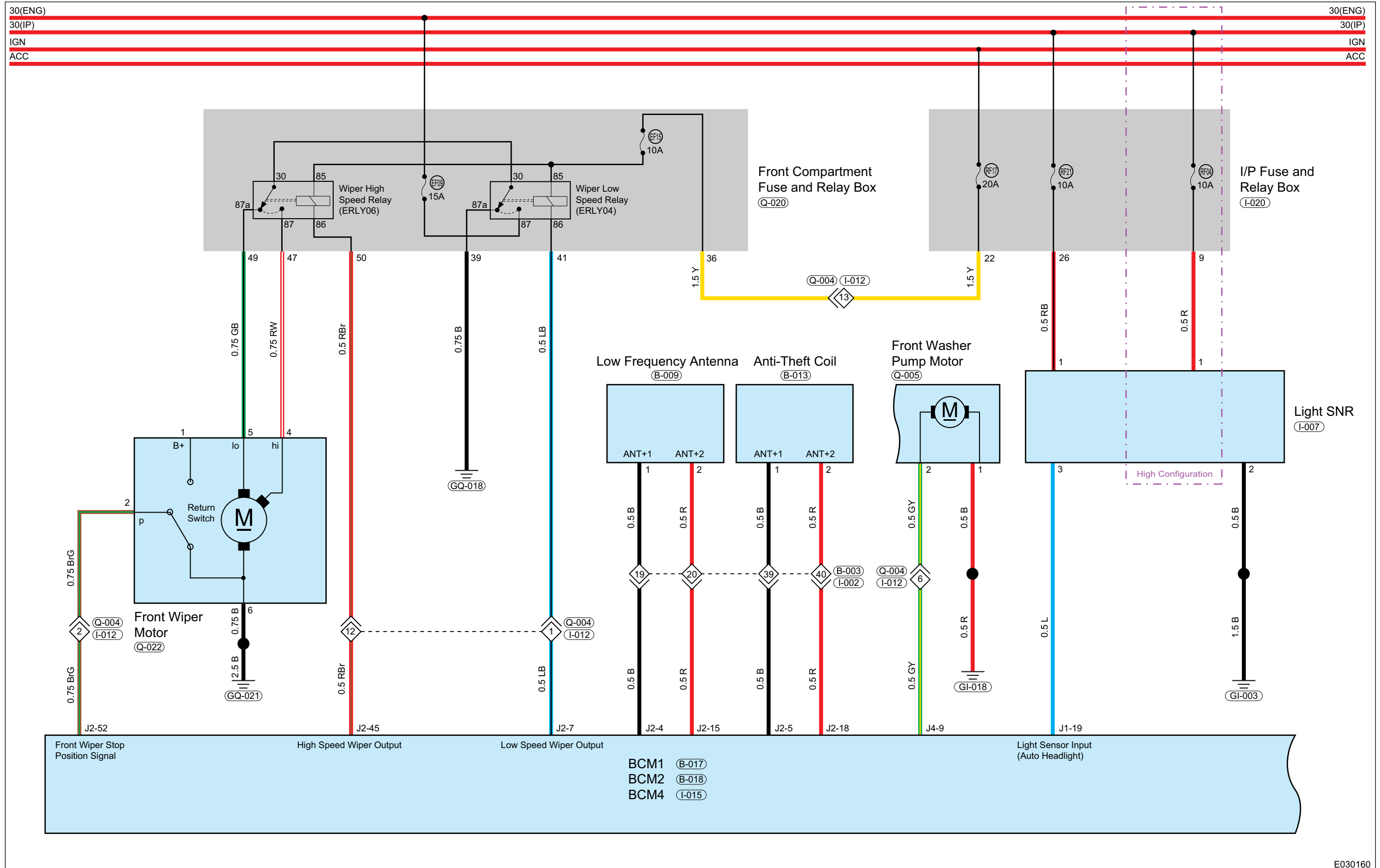

E030160

BCM, Door Glass Regulator SW, Central Lock SW

30(ENG)	30(ENG)
30(IP)	30(IP)
IGN	IGN
ACC	ACC

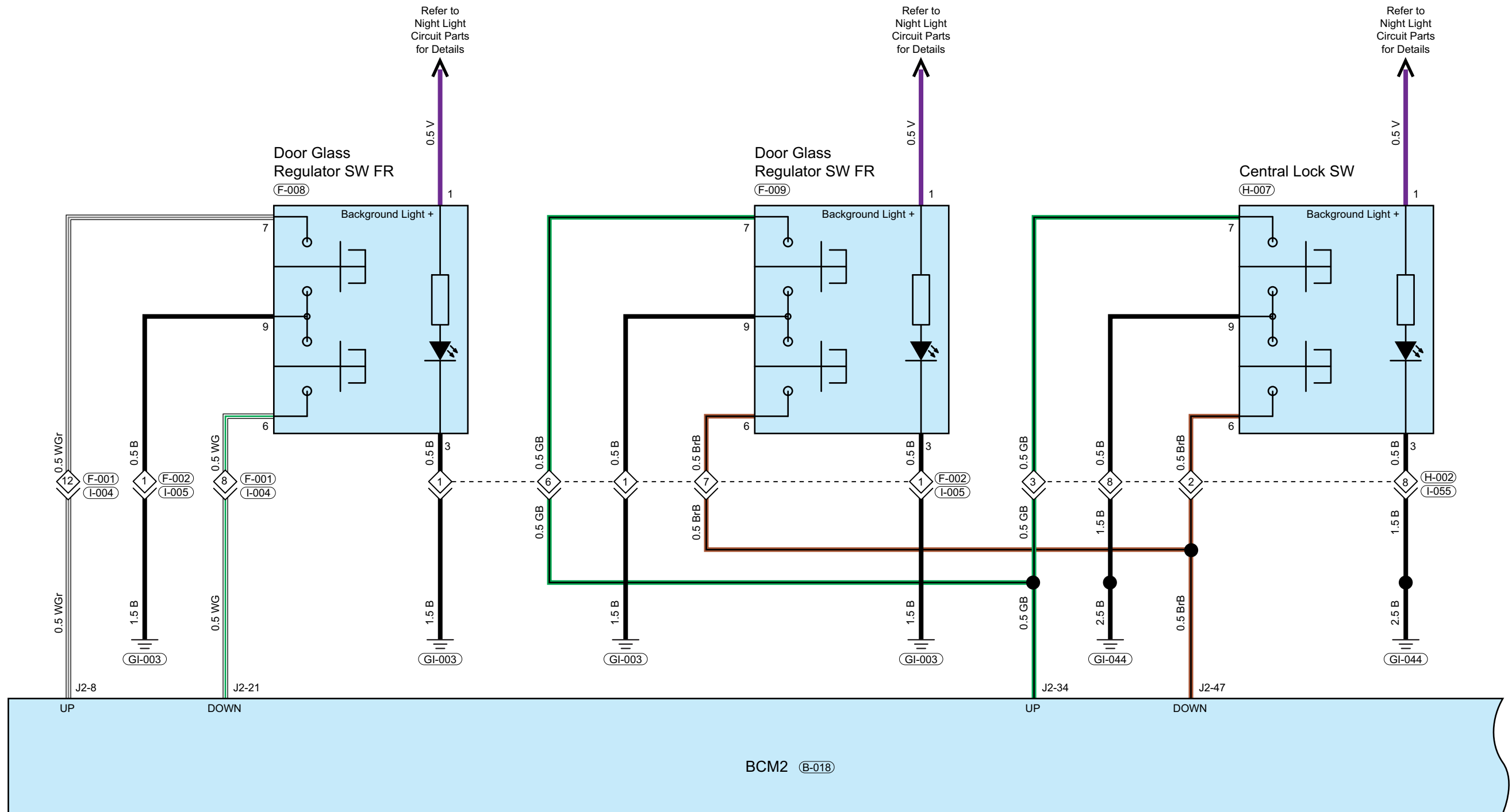

E030170

# System Circuit Diagram

## BCM, Back Door Lock, Central Lock SW, Door Fastener, Door Contact SW FL

30(ENG)	30(ENG)
30(IP)	30(IP)
IGN	IGN
ACC	ACC

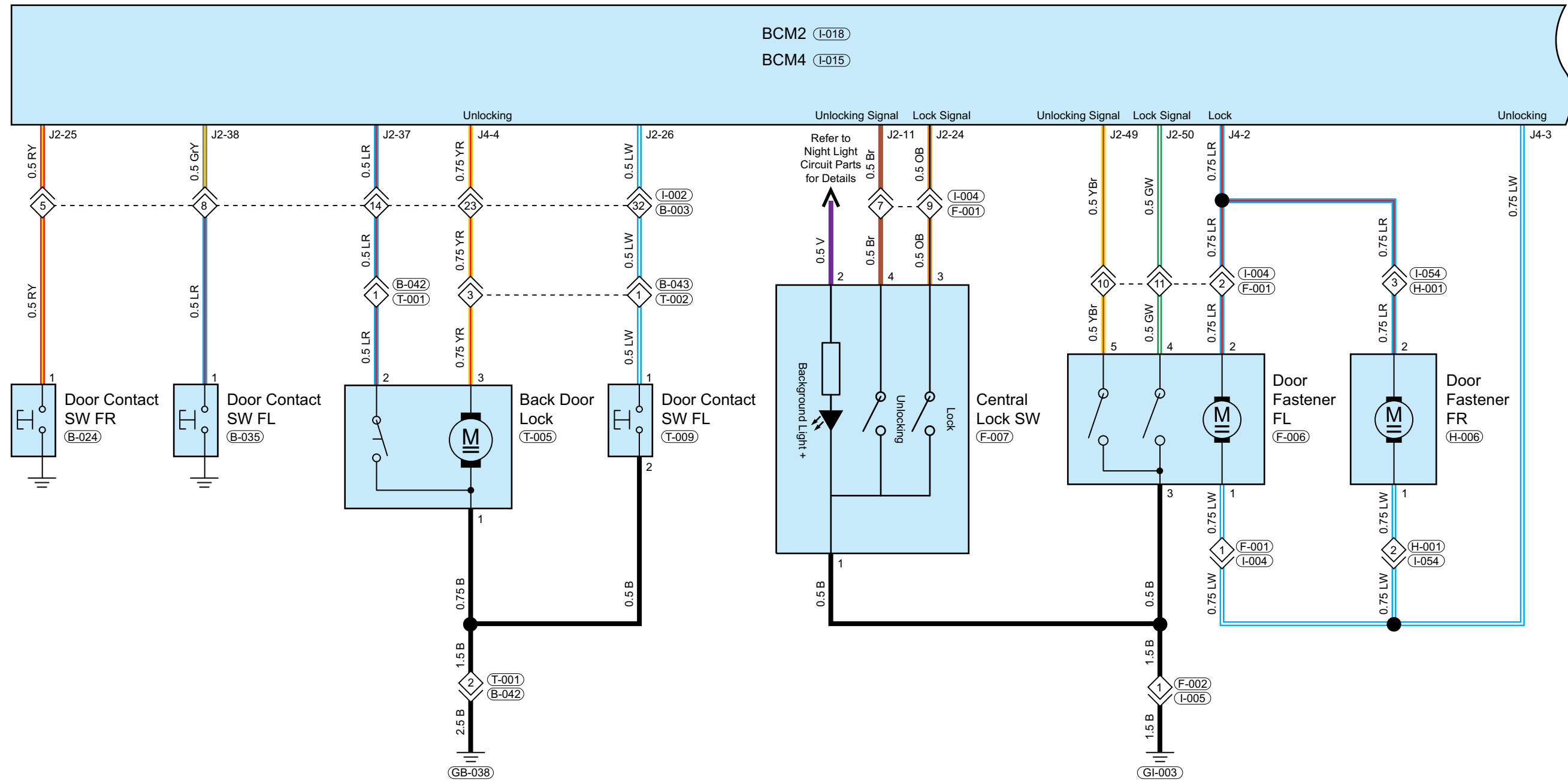

E030180



**VCU**

**VCU, Shift SW, Accelerator Pedal Module, Brake SW**

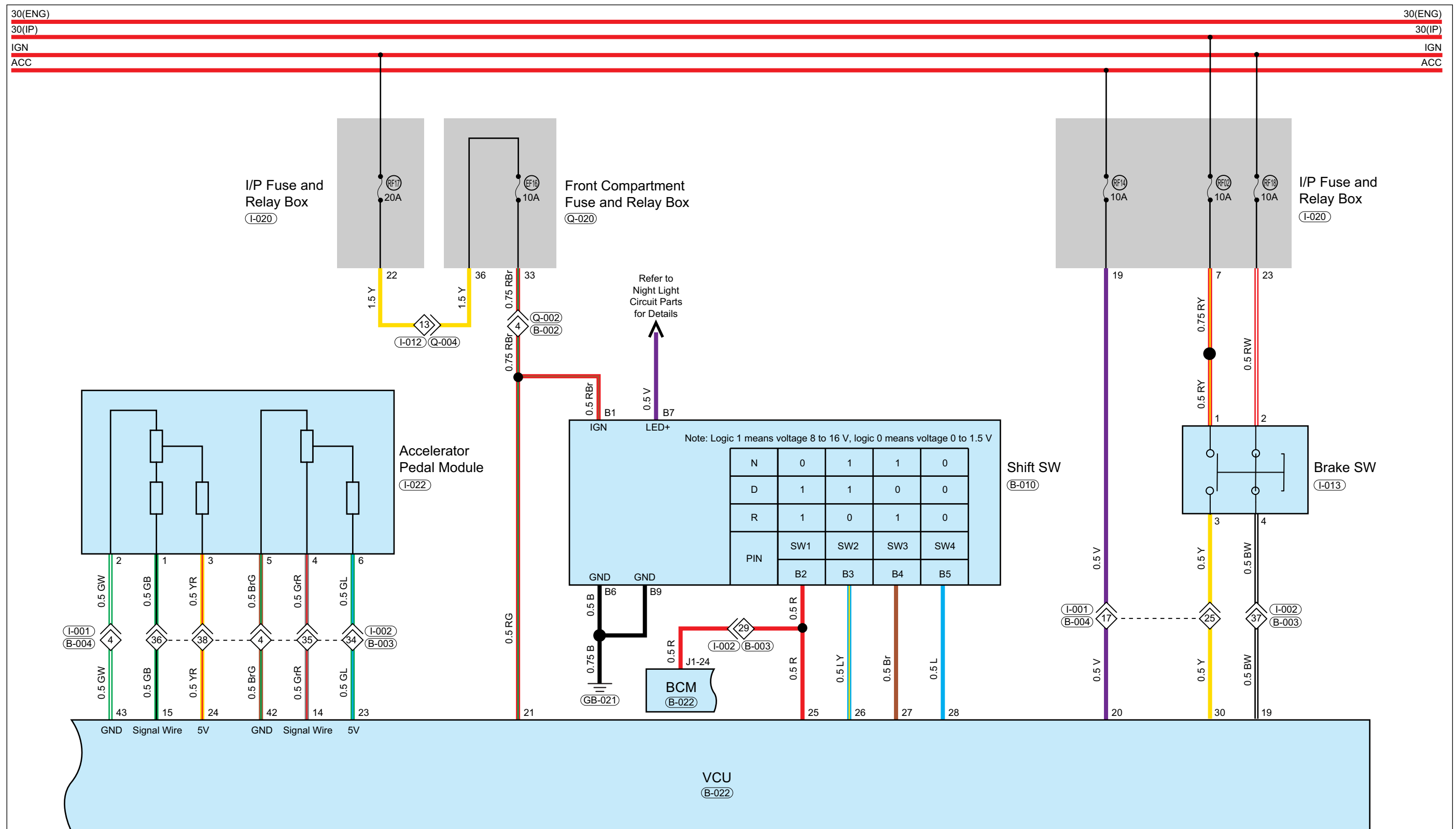

# System Circuit Diagram

## VCU, Three-In-One Controller, CMDC On-Board Charger, A/C Compressor Controller

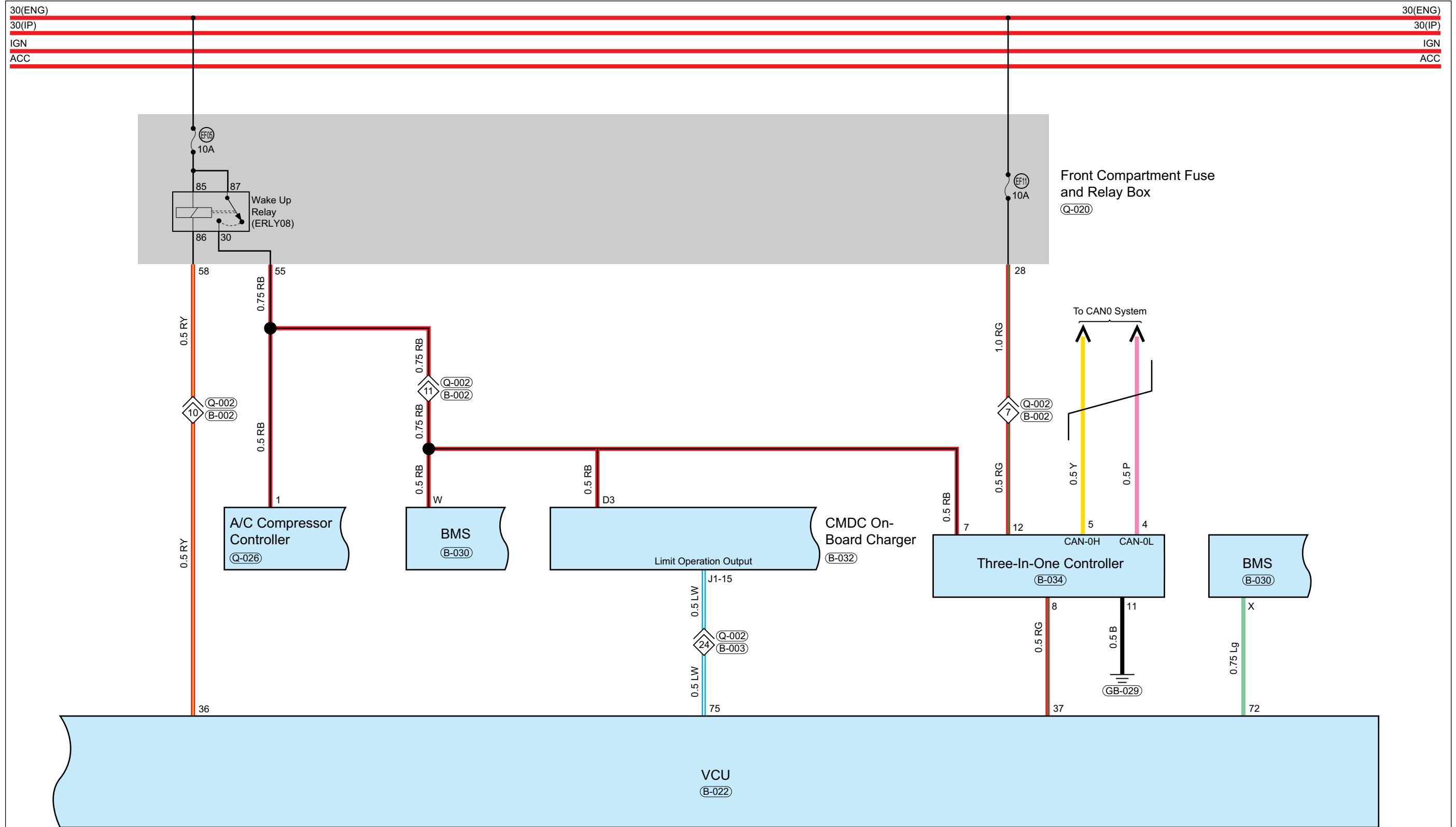

E030200

VCU, Vacuum Pump Operation SNR, Cooling Fan, Cooling Water Pump, Vacuum Pump

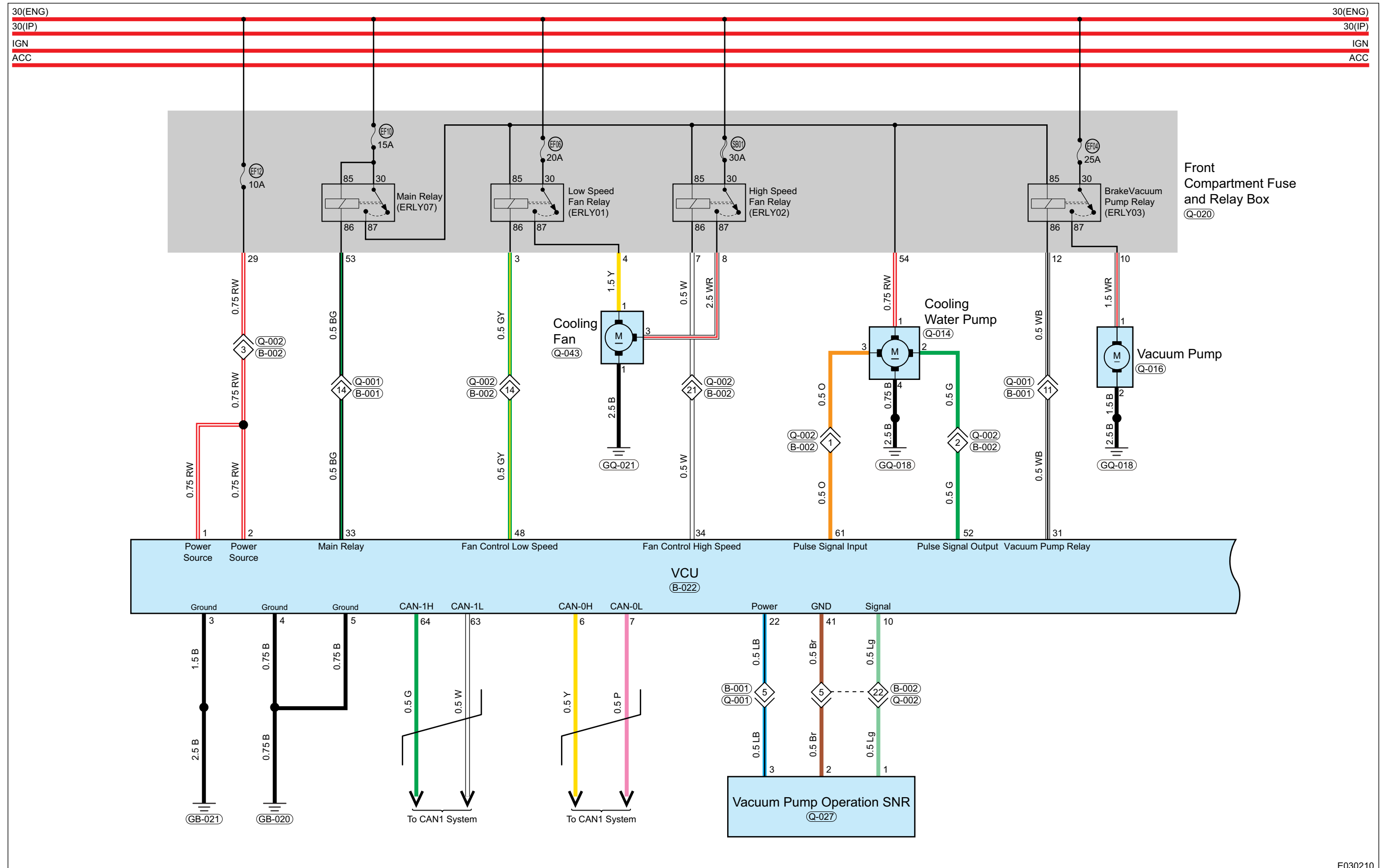

# System Circuit Diagram

## EPB

EPB, ESC Controller, Caliper Motor LH, Caliper Motor RH

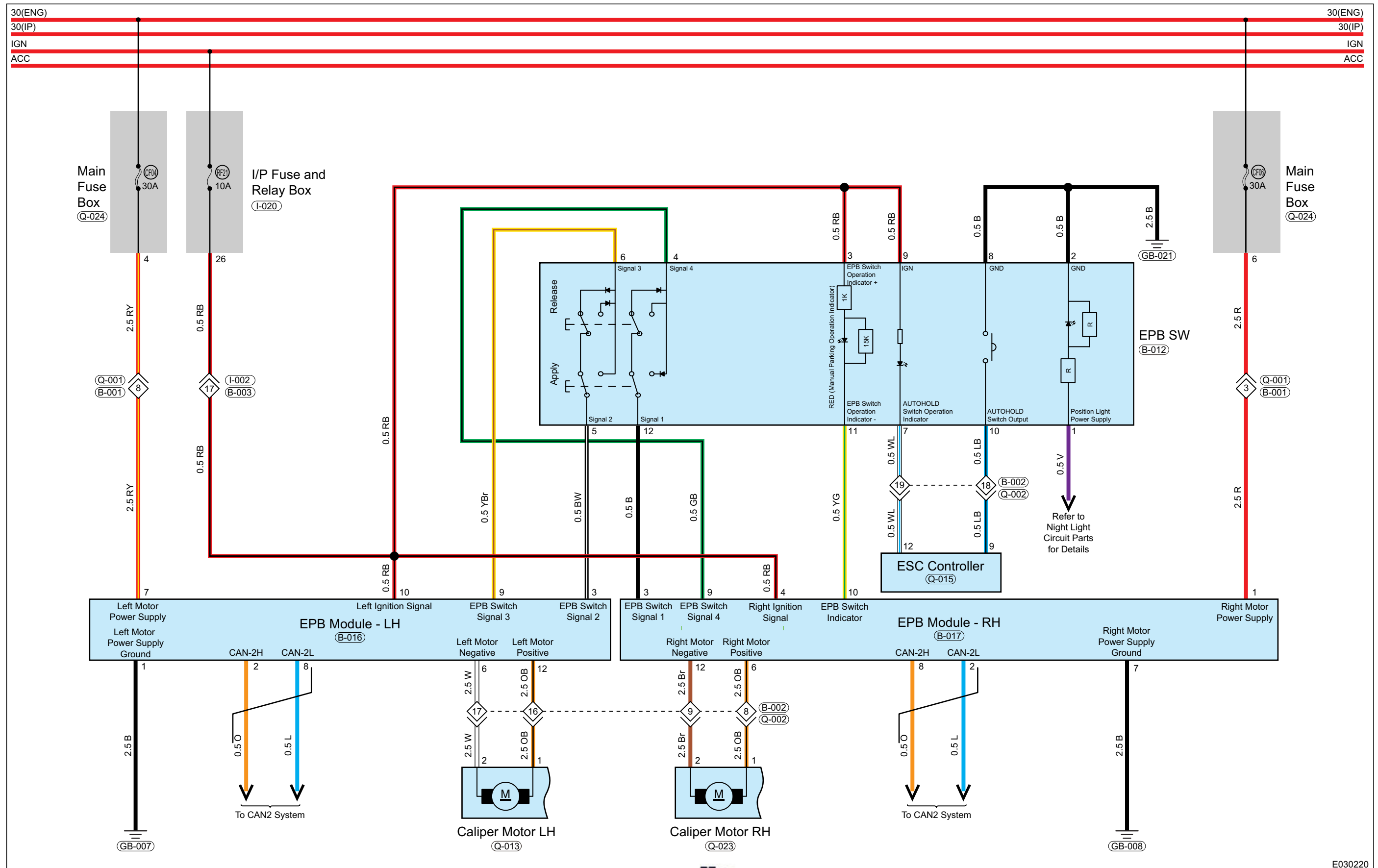

E030220

EPS&SAS&YAS

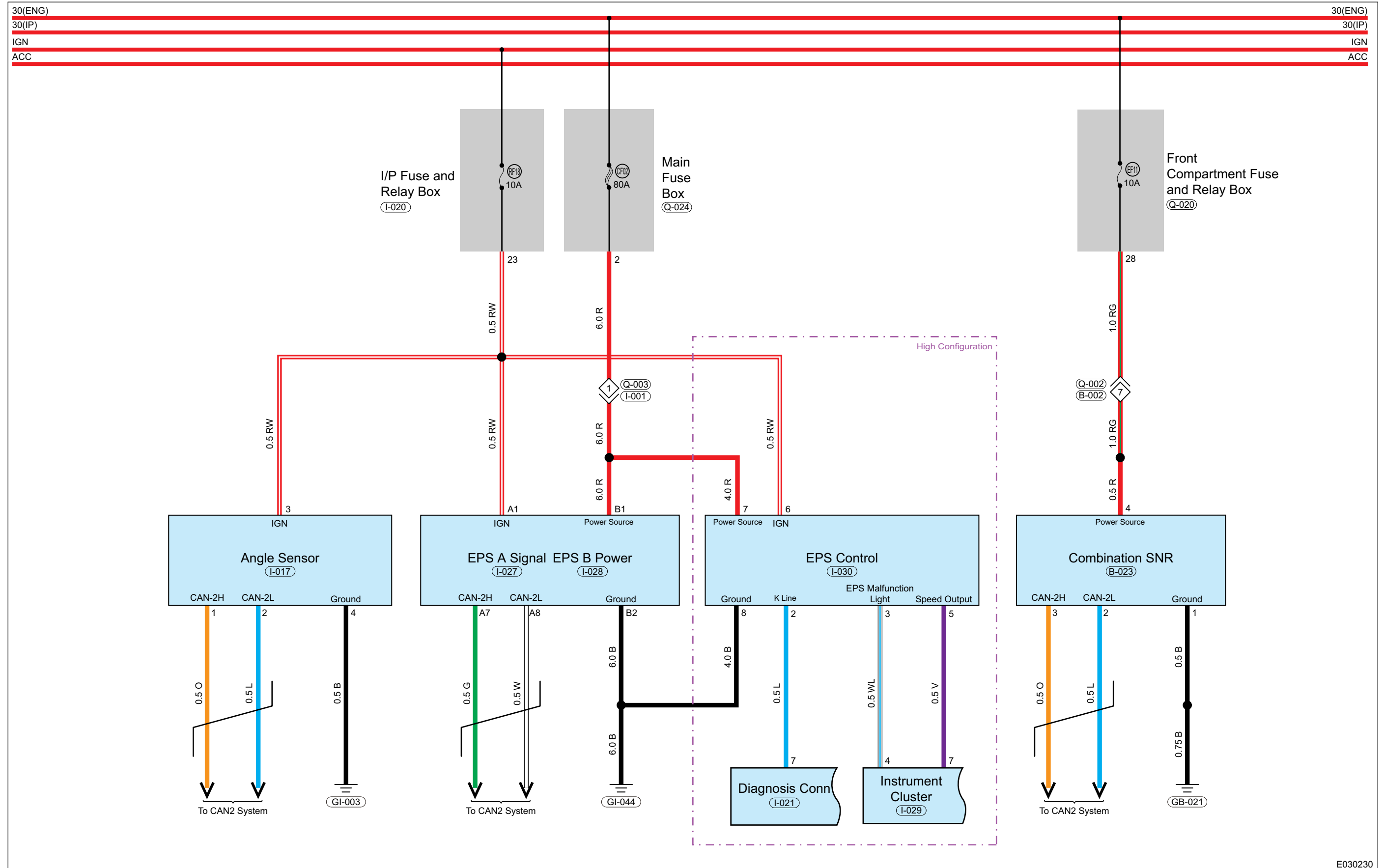

E030230



# System Circuit Diagram

## ESC Controller

ESC Controller, Wheel Speed SNR FL, Wheel Speed SNR FR, Wheel Speed SNR RL, Wheel Speed SNR RR, Brake SW

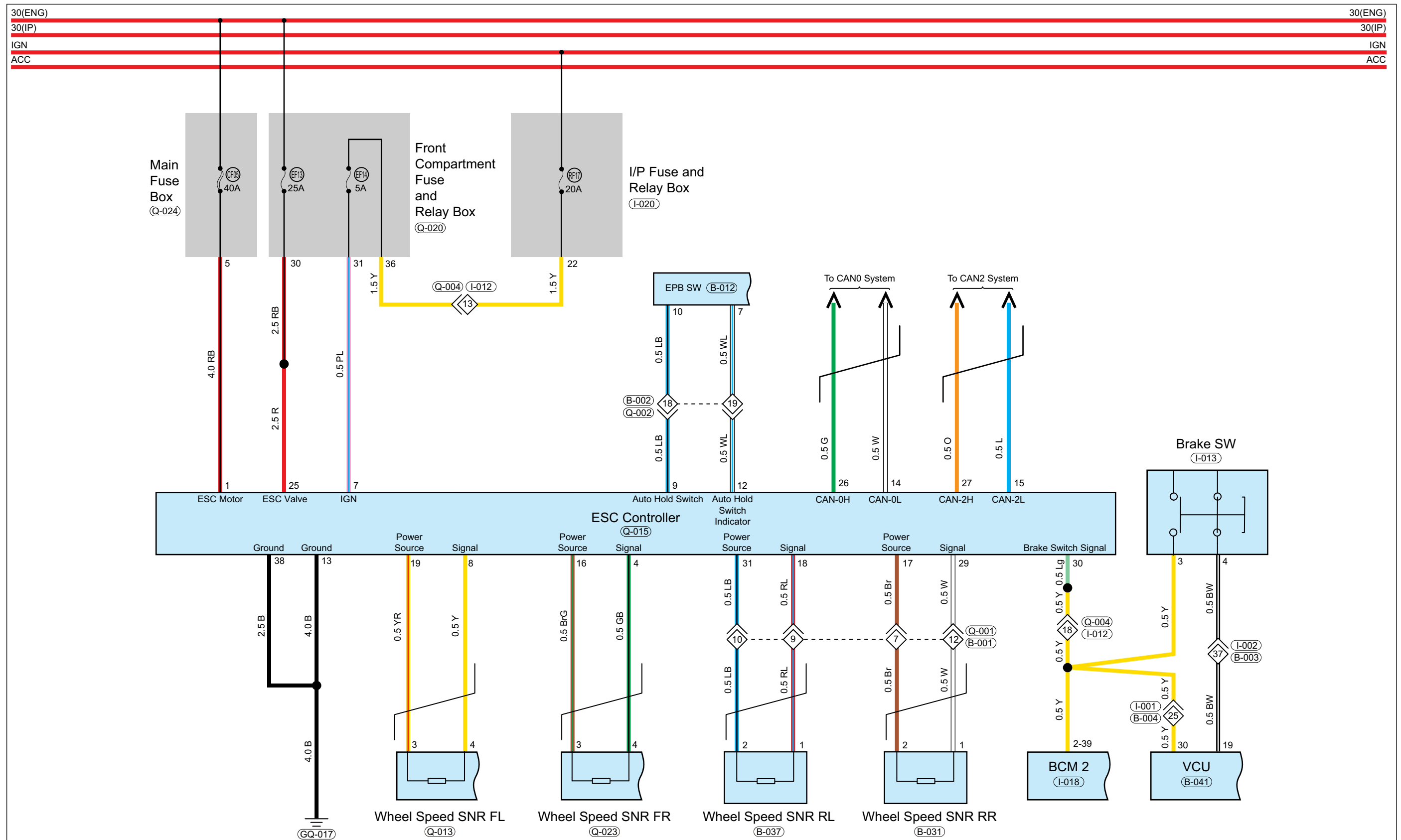

E030240

# Electric Rearview Mirror

## Power Rear View Mirror, Power Rear View Mirror SW

30(ENG) 30(ENG)  
 30(IP) 30(IP)  
 IGN IGN  
 ACC ACC

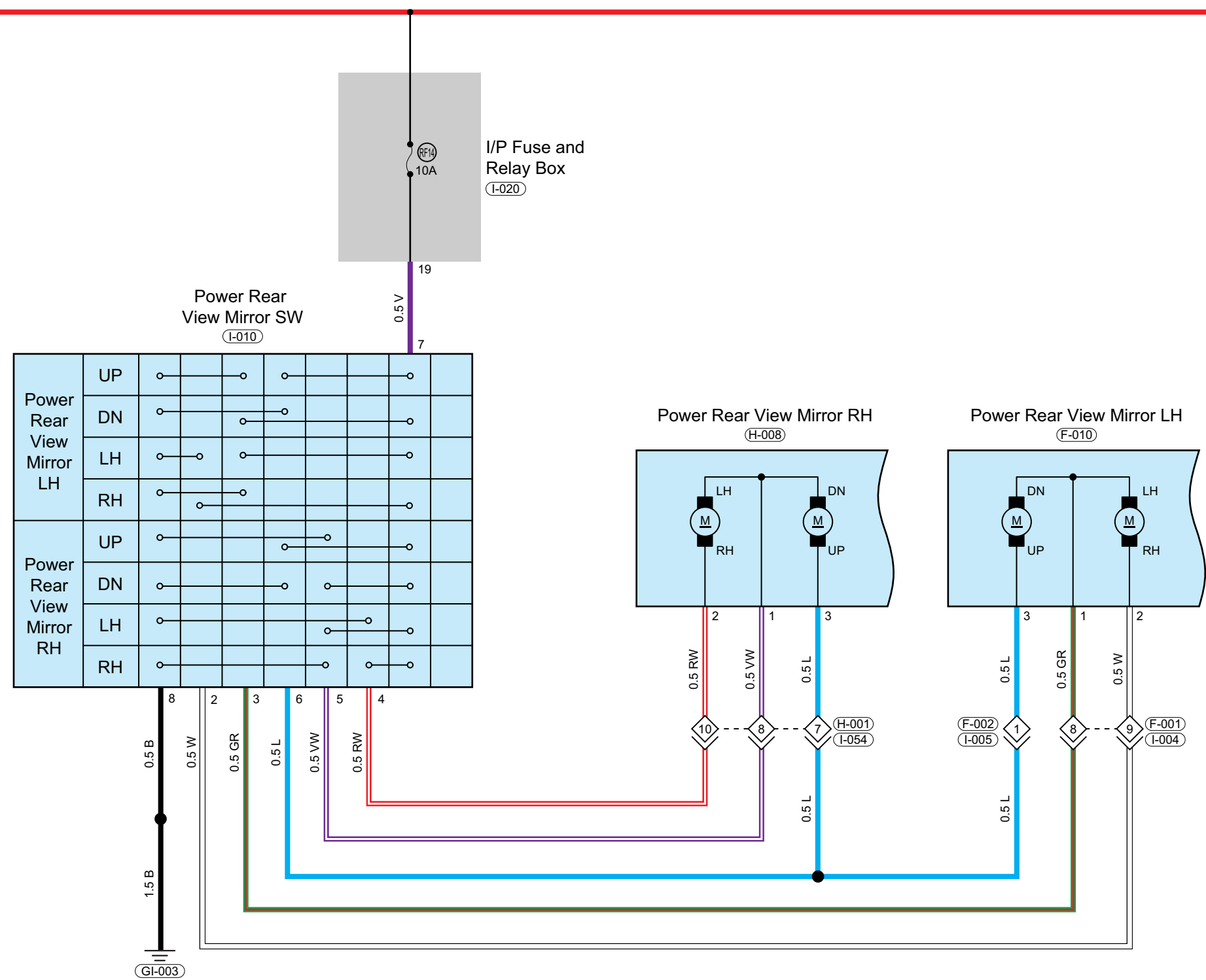

# System Circuit Diagram

## Power Rear View Mirror, Power Rear View Mirror SW (High Configuration)

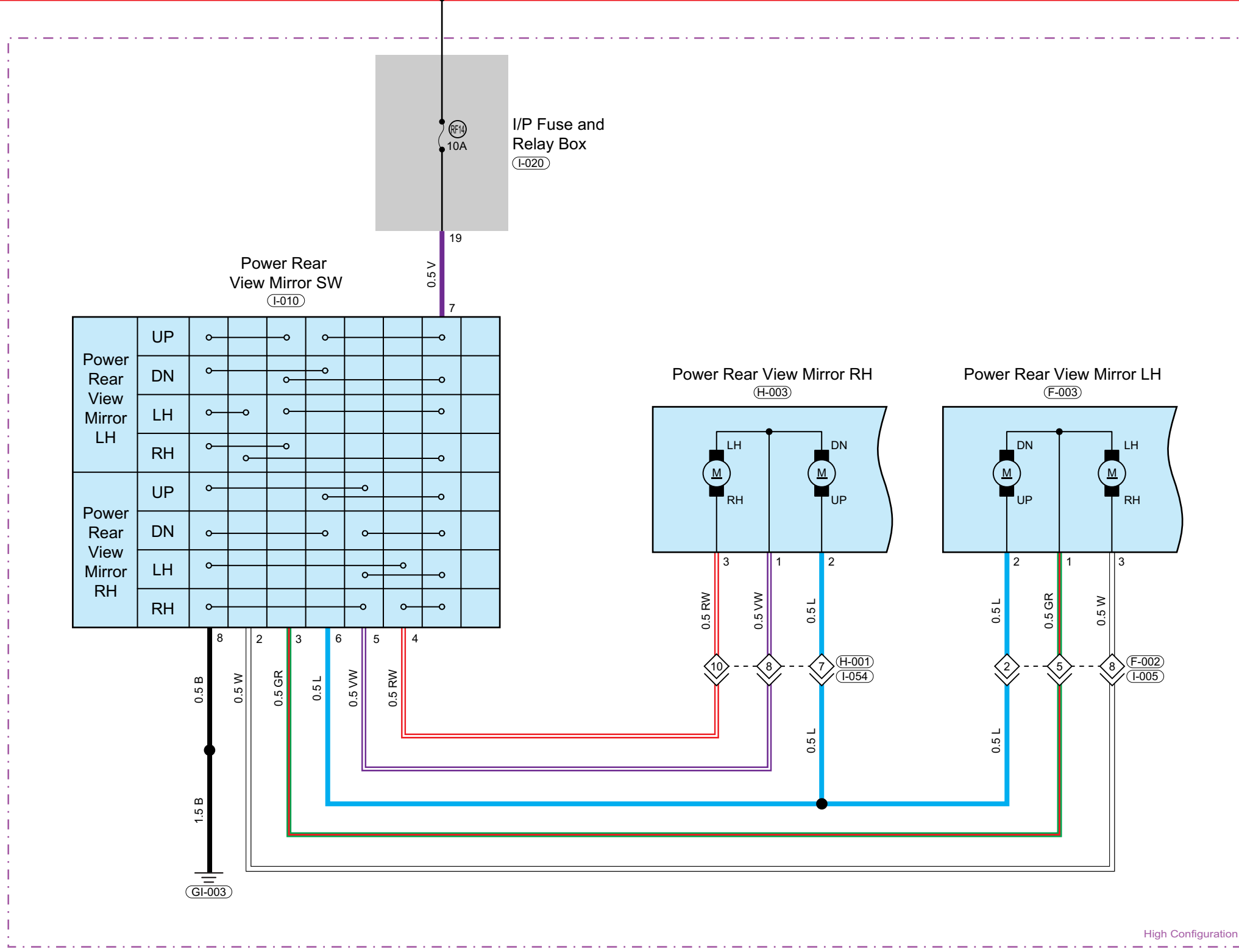

E030260

Power Seat

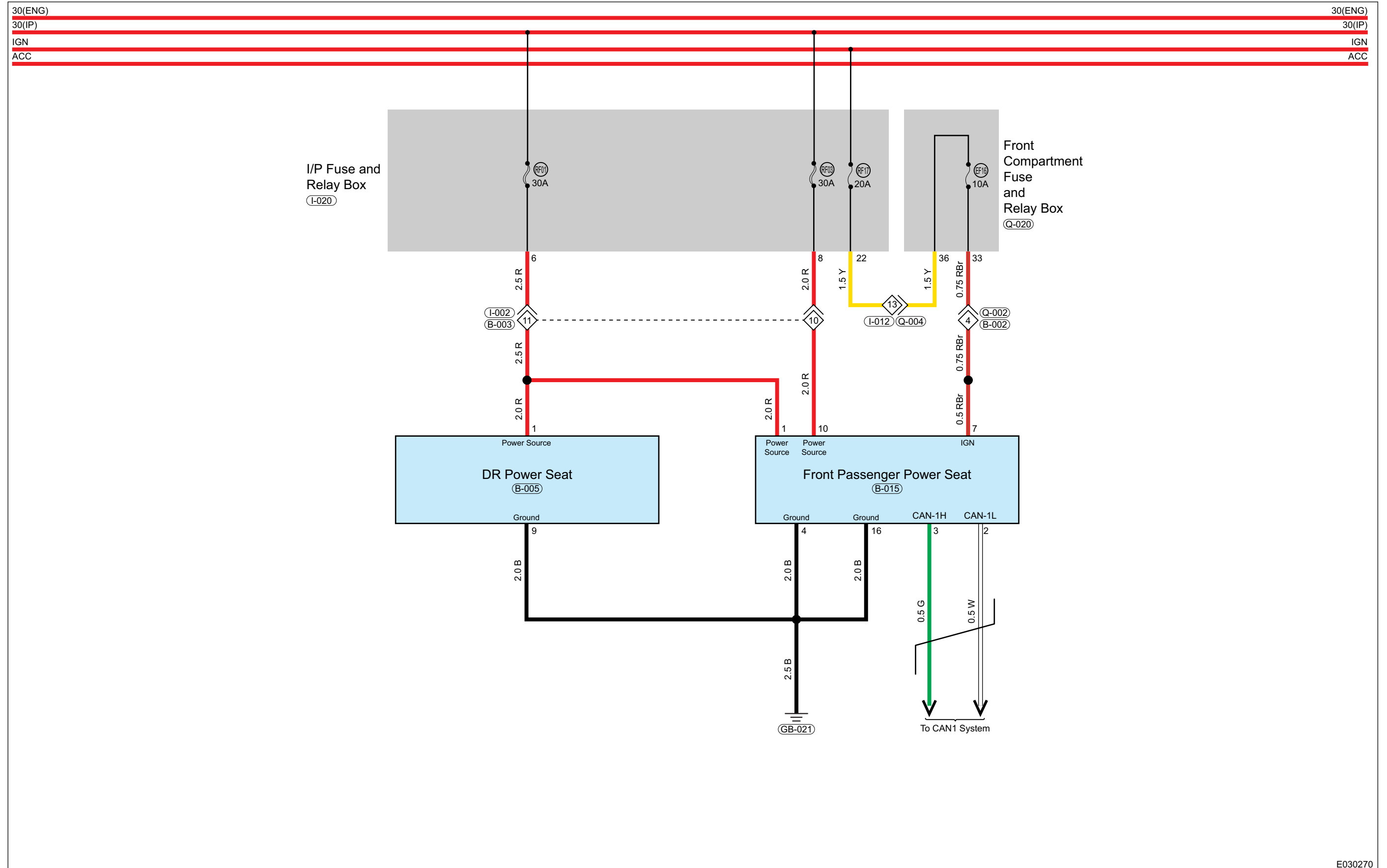

E030270

# System Circuit Diagram

## A/C Controller System

A/C Controller, Blower, Speed Regulation Resistance, A/C High/Low Pressure SW, Evaporator Temp SNR, Exterior Temp SNR, Clock Spring, Steering Wheel Button, VCU, Mix Damper Motor, Mode Motor, Circulation Motor

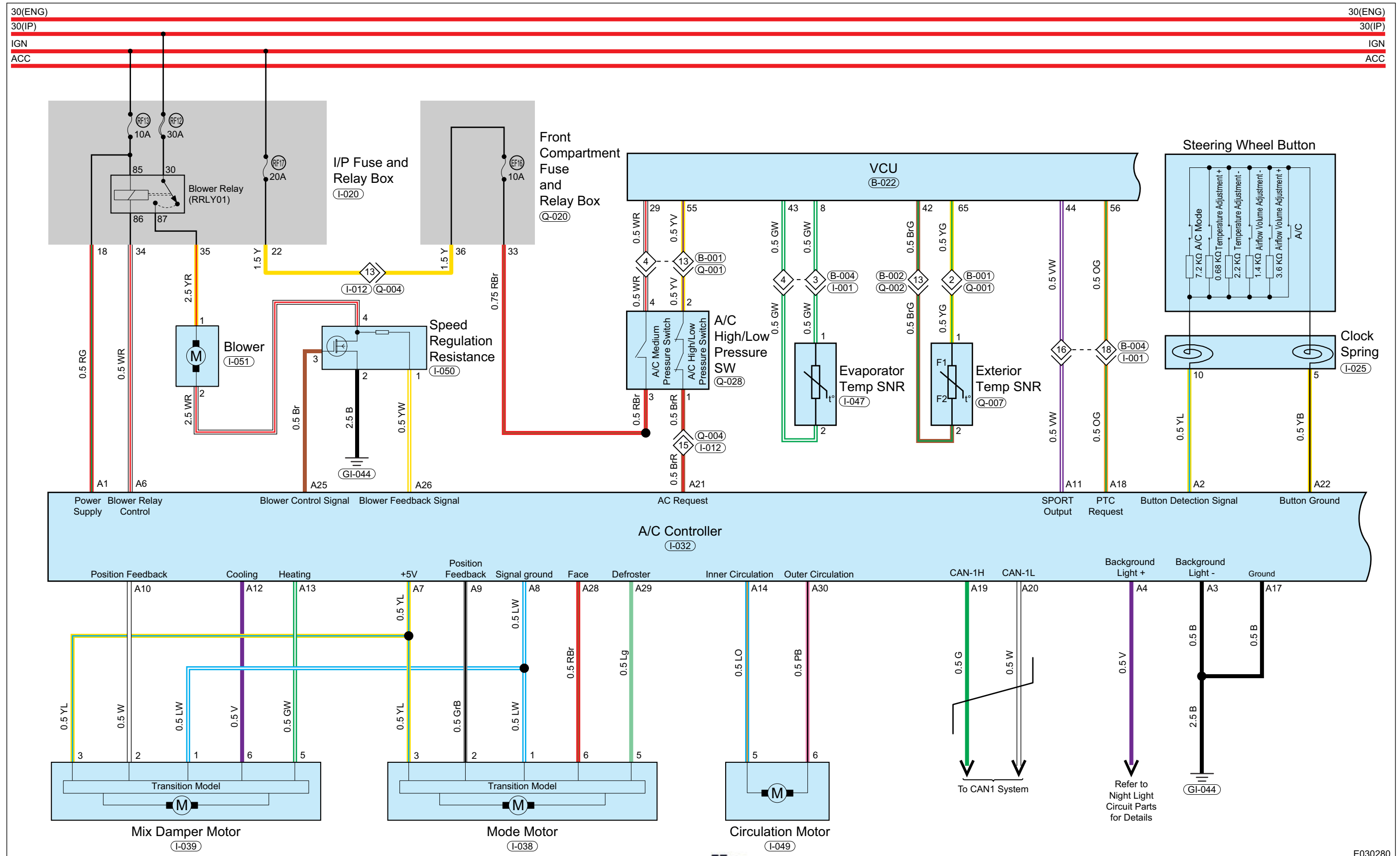

E030280



A/C Compressor Controller, PTC Relay Signal, A/C Controller, Power Rear View Mirror LH, Power Rear View Mirror RH, Rear Defrost

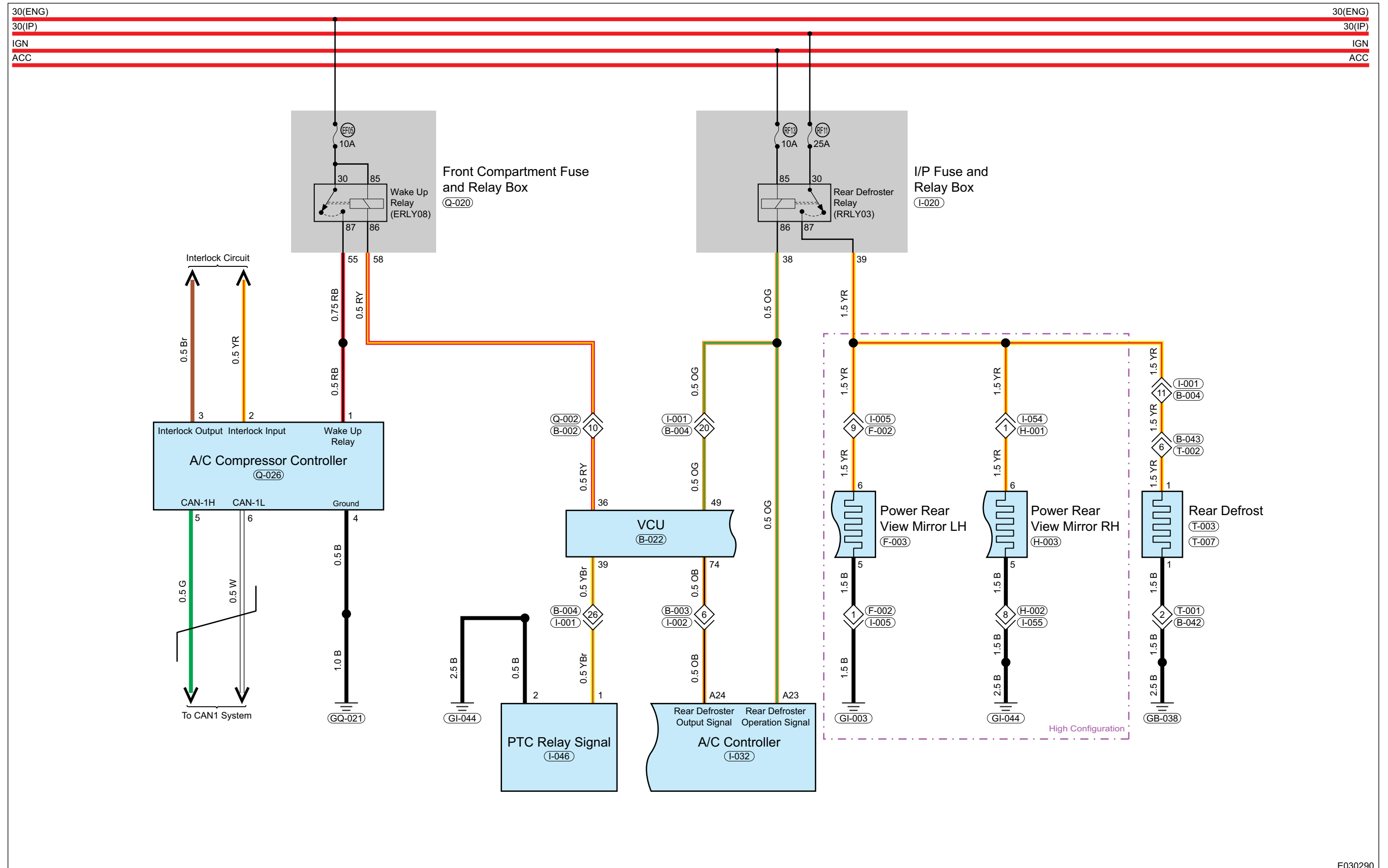

E030290

Instrument Cluster

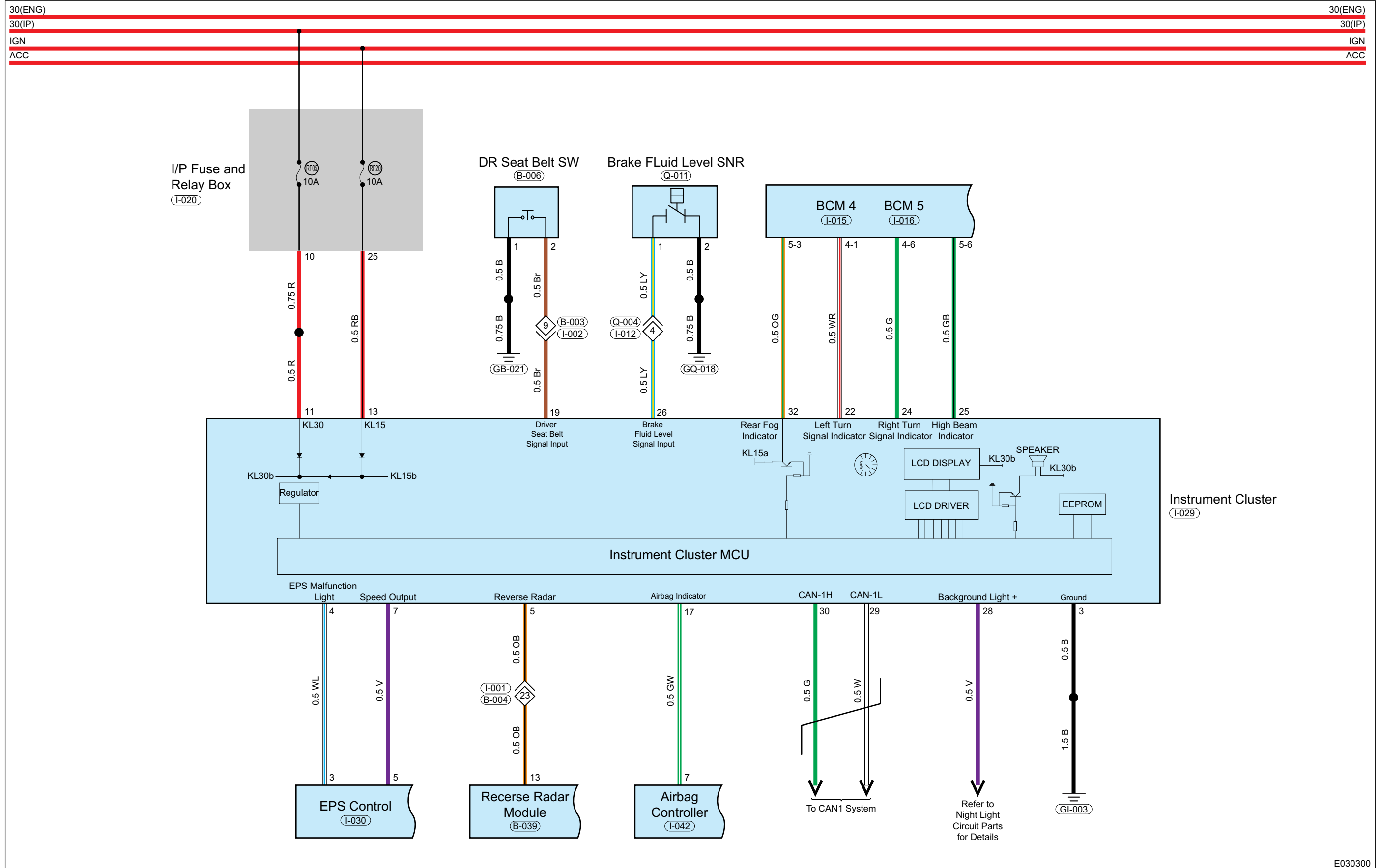

E030300

Audio Entertainment System

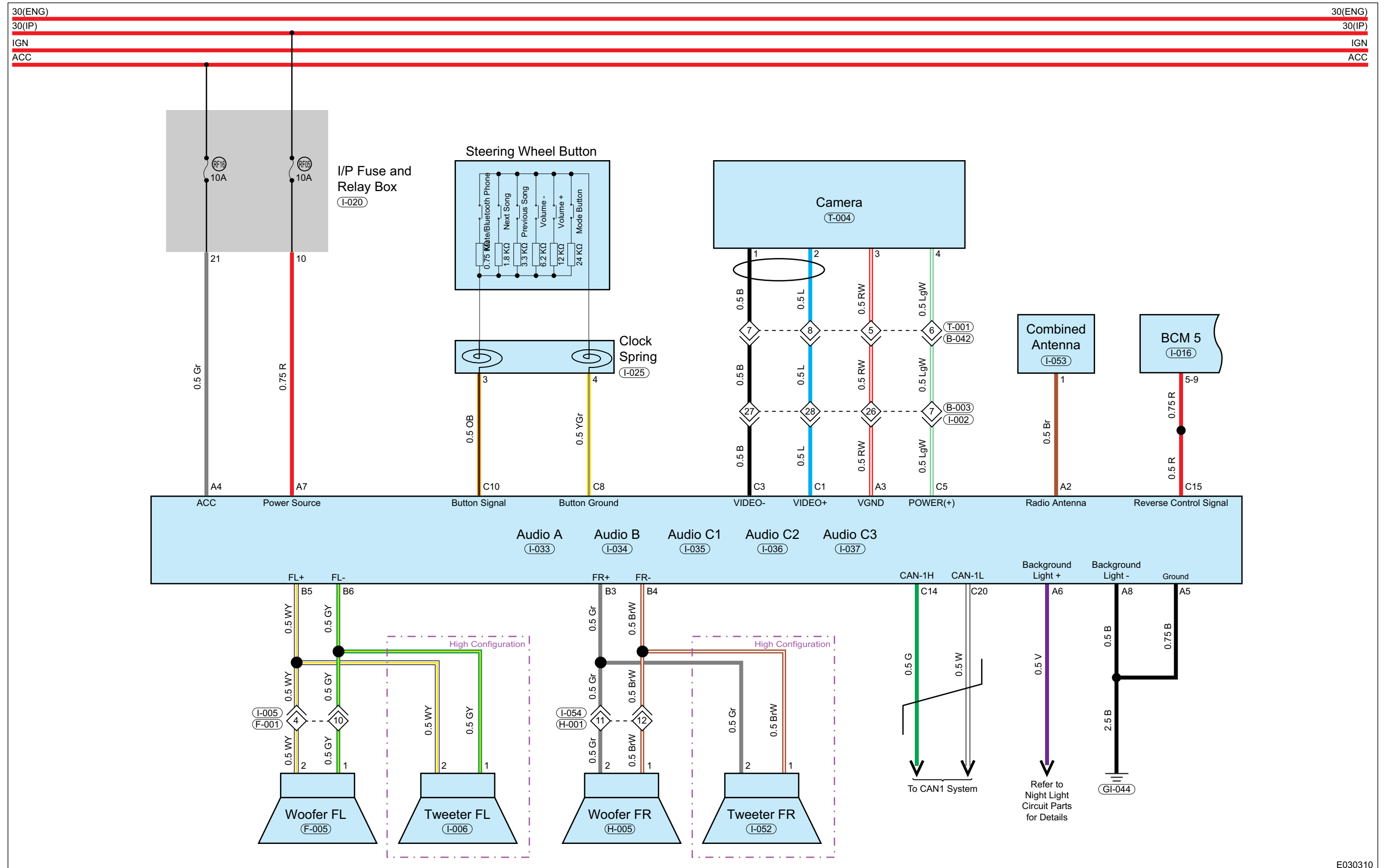

E030310

# System Circuit Diagram

## Airbag

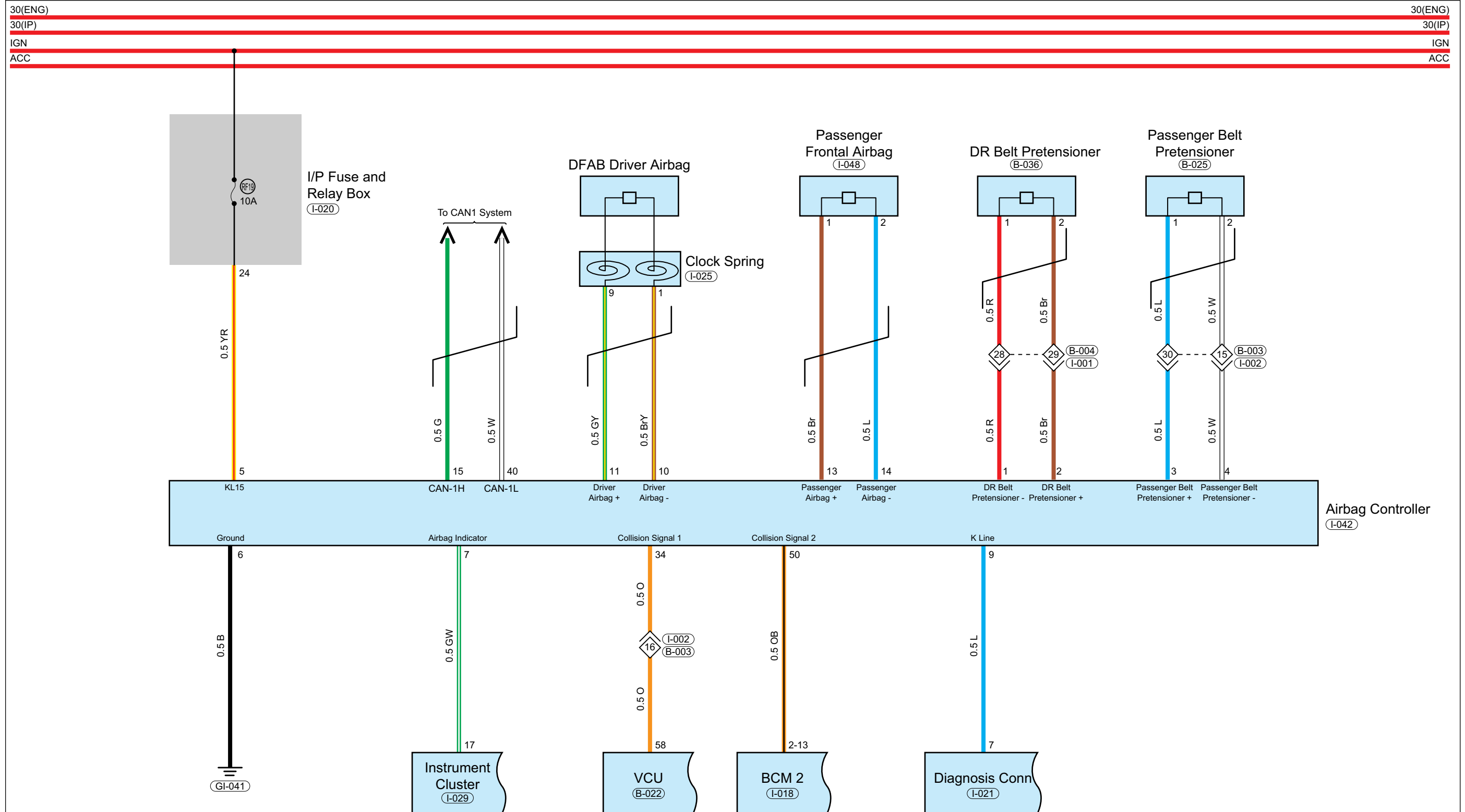

E030320

Pedestrian Alert, Tire Pressure Monitoring, Reversing Radar

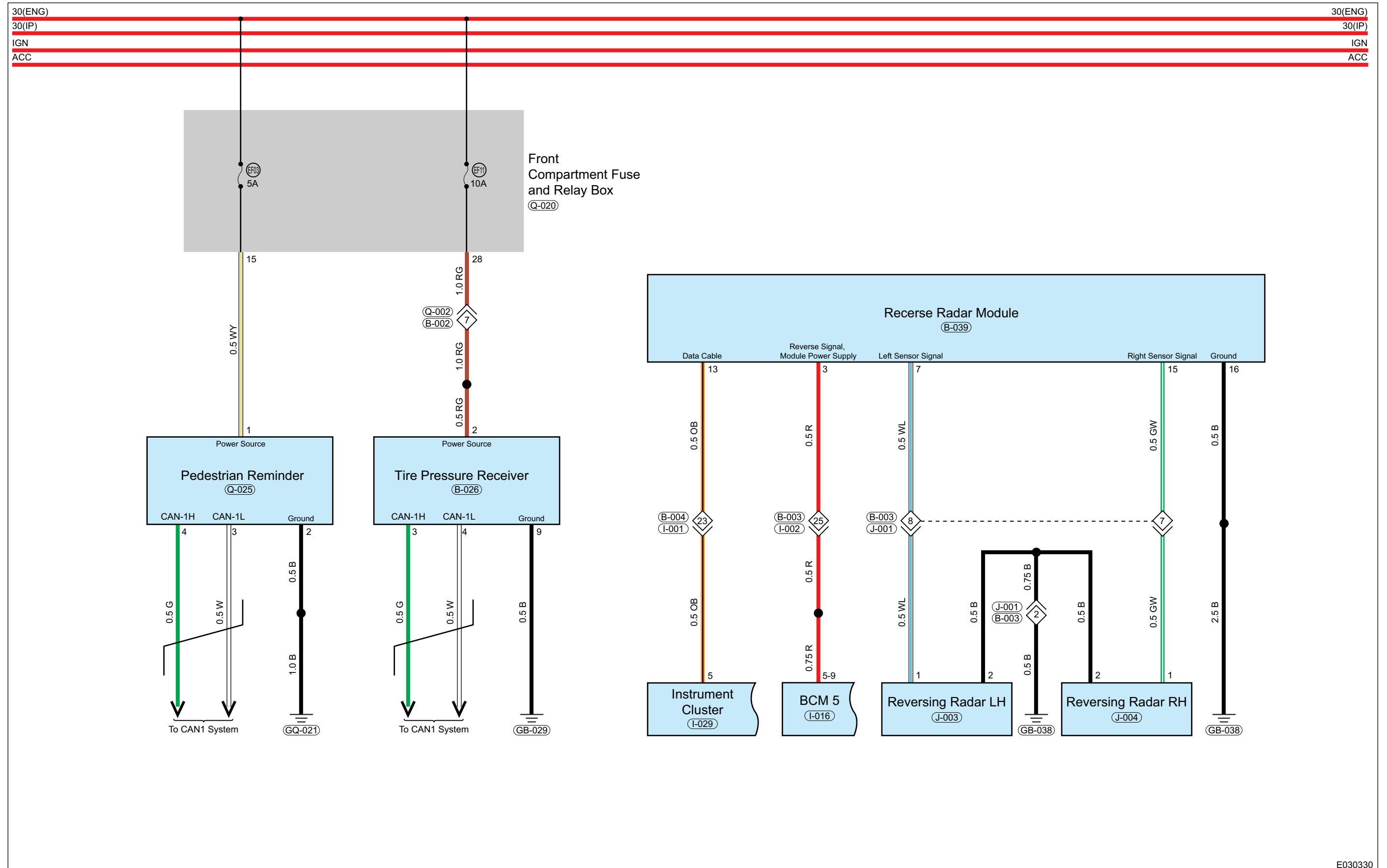

E030330



Wireless Charging, Backup Power Supply

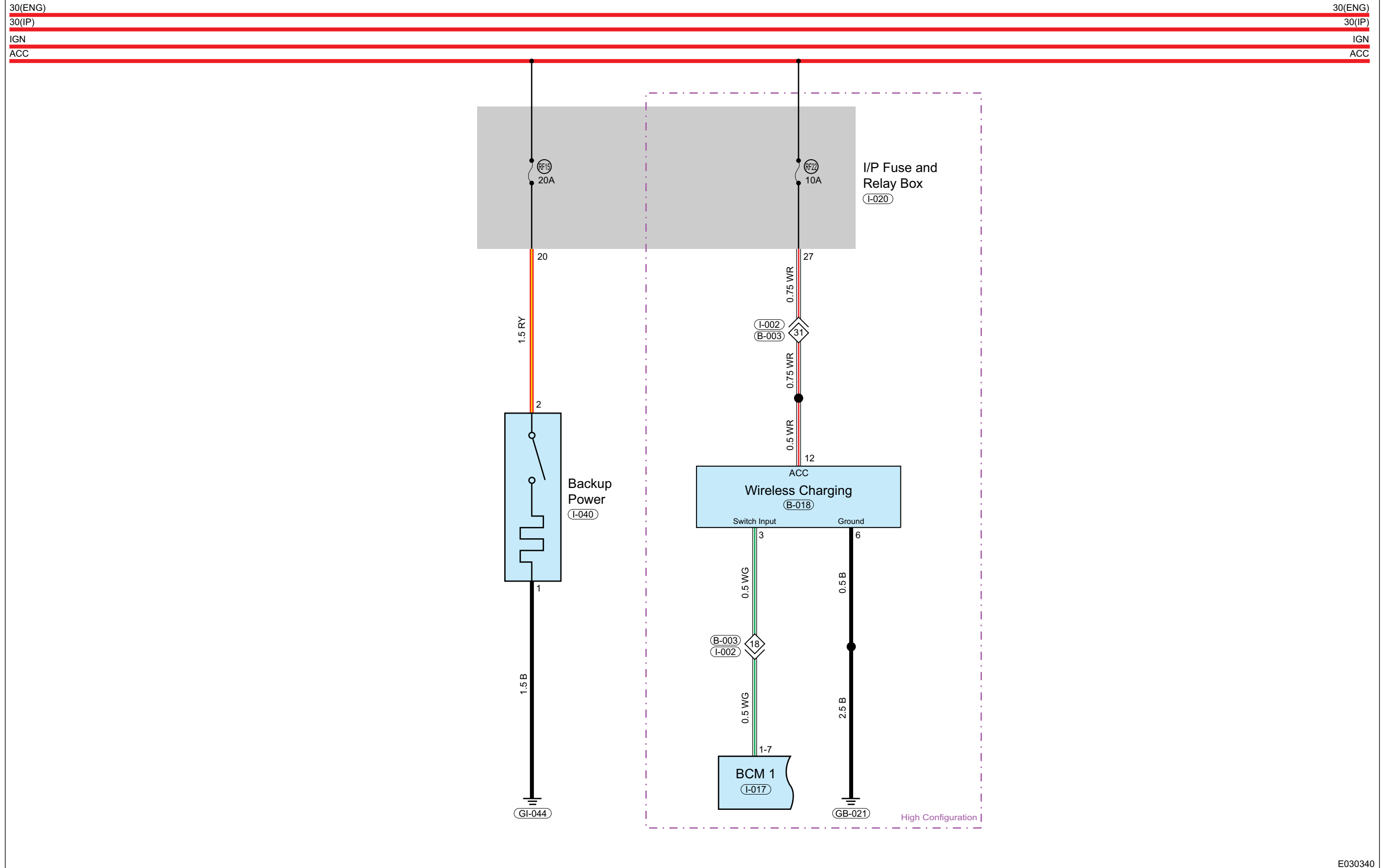

E030340

# Network Topology Diagram

## CGW Central Gateway

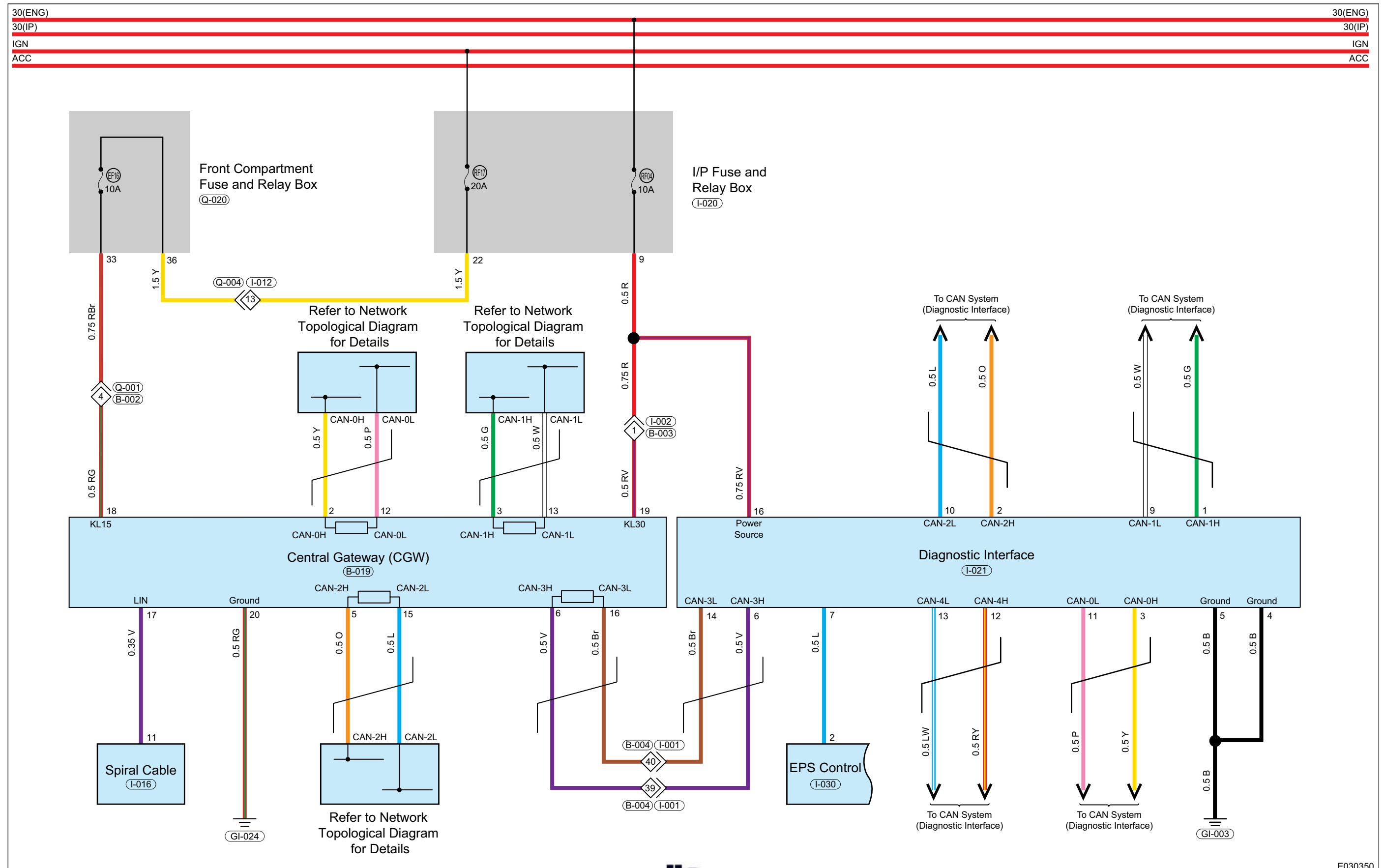

# System Circuit Diagram

## CAN0

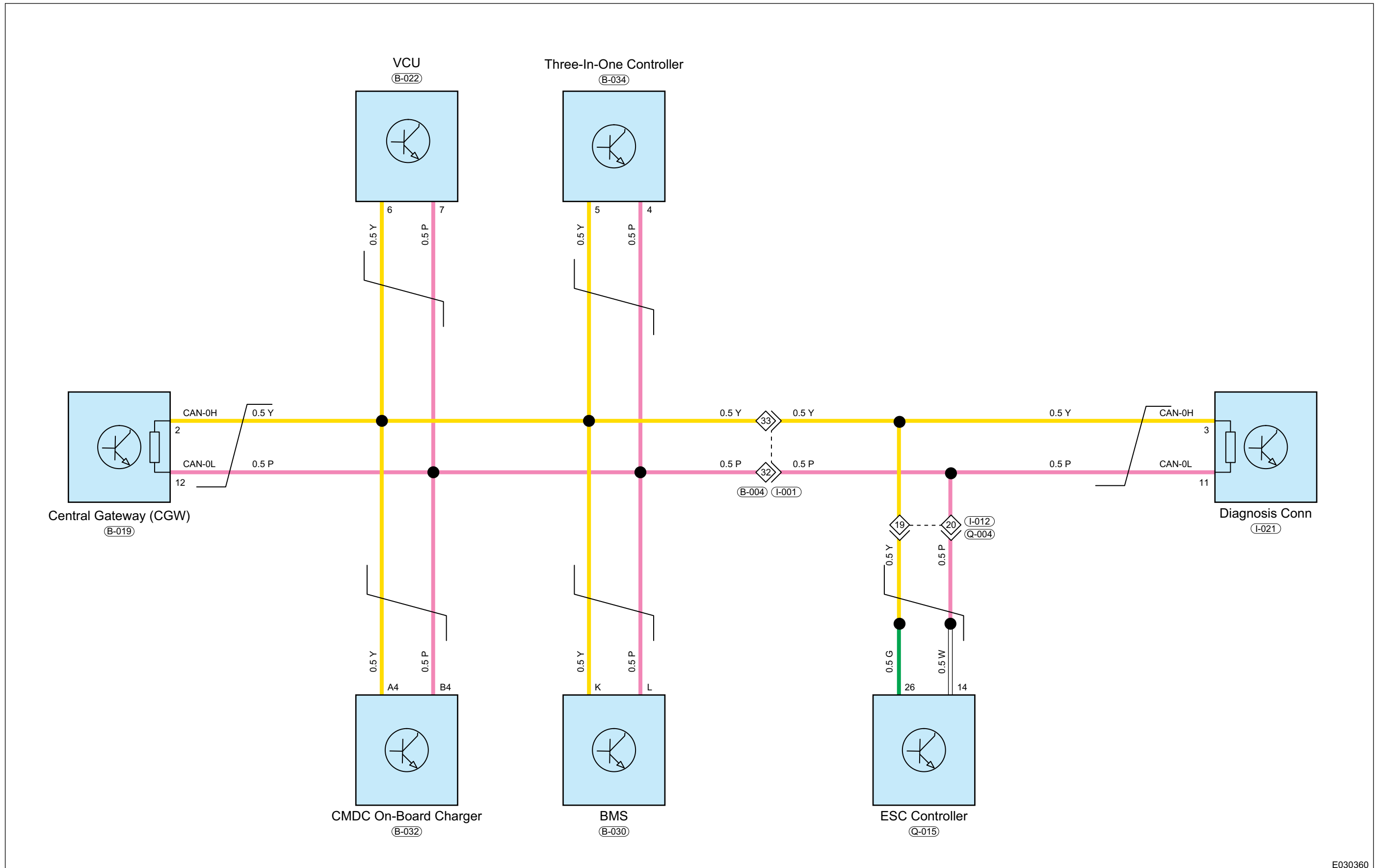

E030360

CAN1

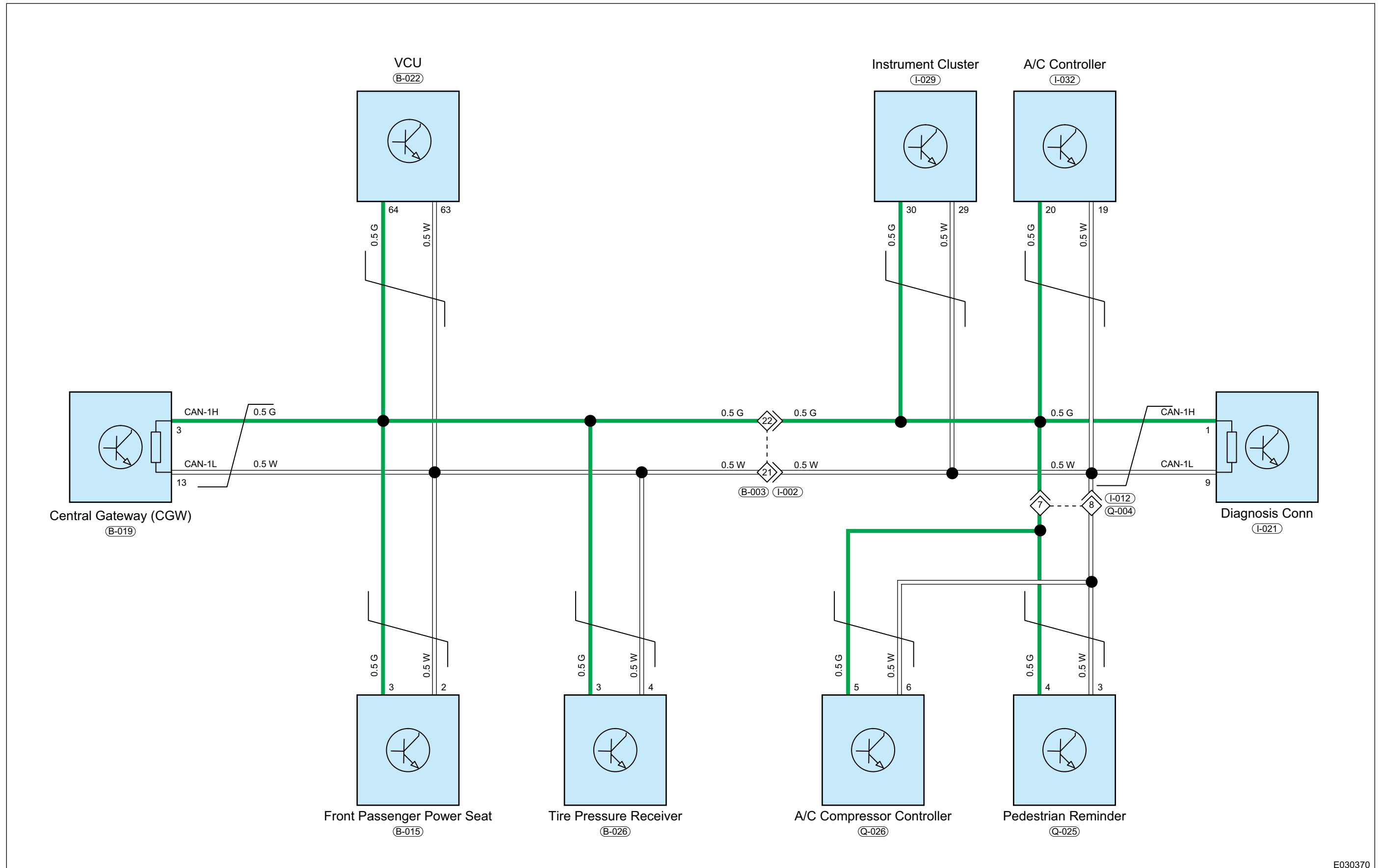

E030370

# System Circuit Diagram

## CAN2

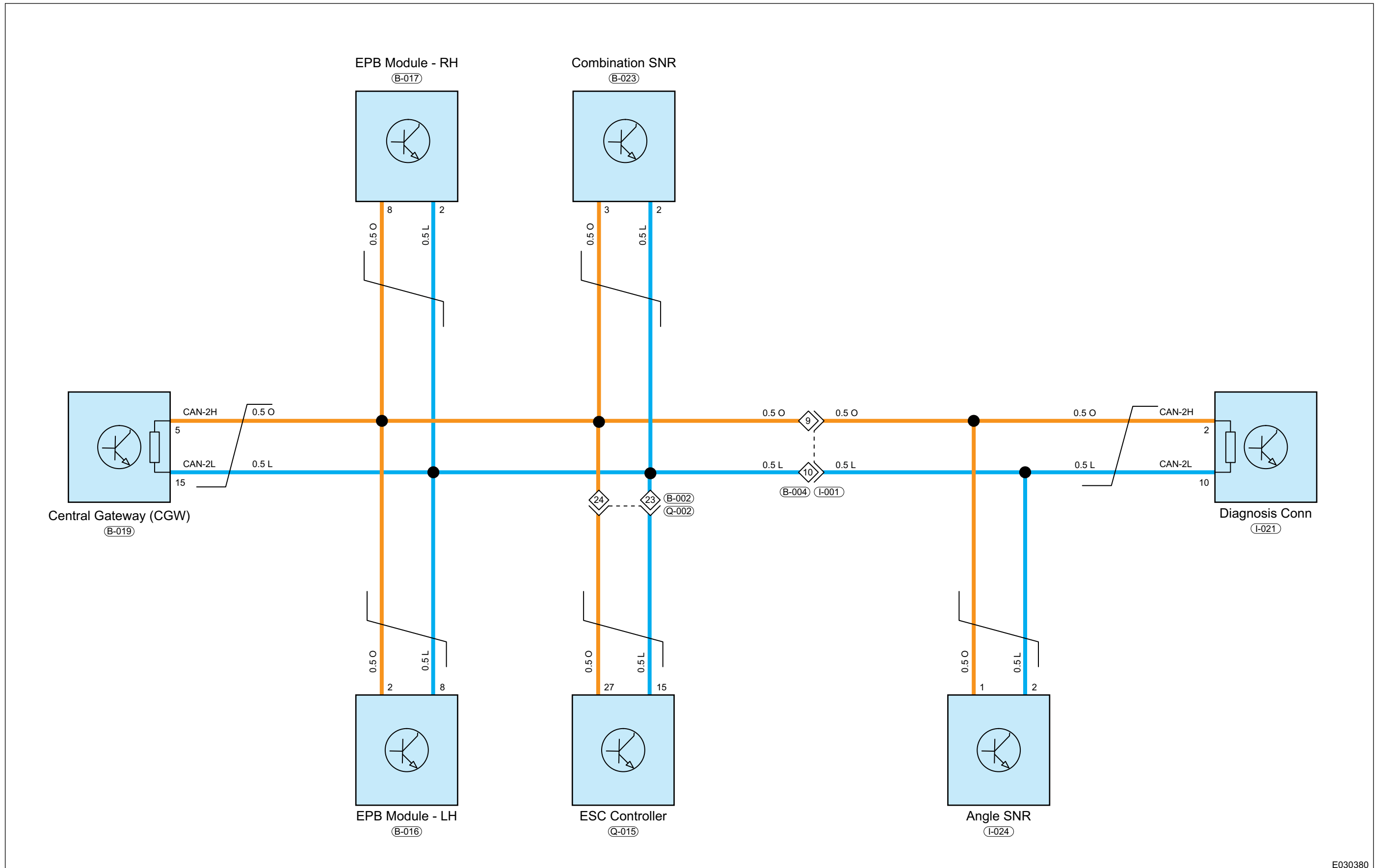

E030380



CAN3

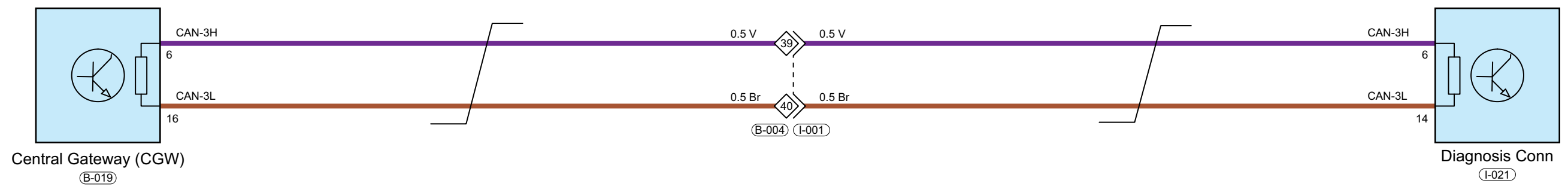

E030390