

# DRIVE SHAFT SYSTEM

## PROBLEM SYMPTOMS TABLE

### HINT:

Use the table below to help determine the cause of the problem symptom. The potential causes of the symptoms are listed in order of probability in the "Suspected area" column of the table. Check each symptom by checking the suspected areas in the order they are listed. Replace parts as necessary.

### Drive shaft system

Symptom	Suspected area	See page
Front wheel shimmy	1. Front drive shaft (worn)	DS-7
	2. Wheel (unbalance)	TW-4
	3. Hub bearing	AH-4
	4. Front lower ball joint	SP-24
	5. Front shock absorber with coil spring	SP-14
Noise (front)	1. Front shock absorber with coil spring	SP-14
	2. Front drive shaft	DS-7
	3. Hub bearing	AH-4
	4. Front lower ball joint	SP-24

# FRONT DRIVE SHAFT

## COMPONENTS

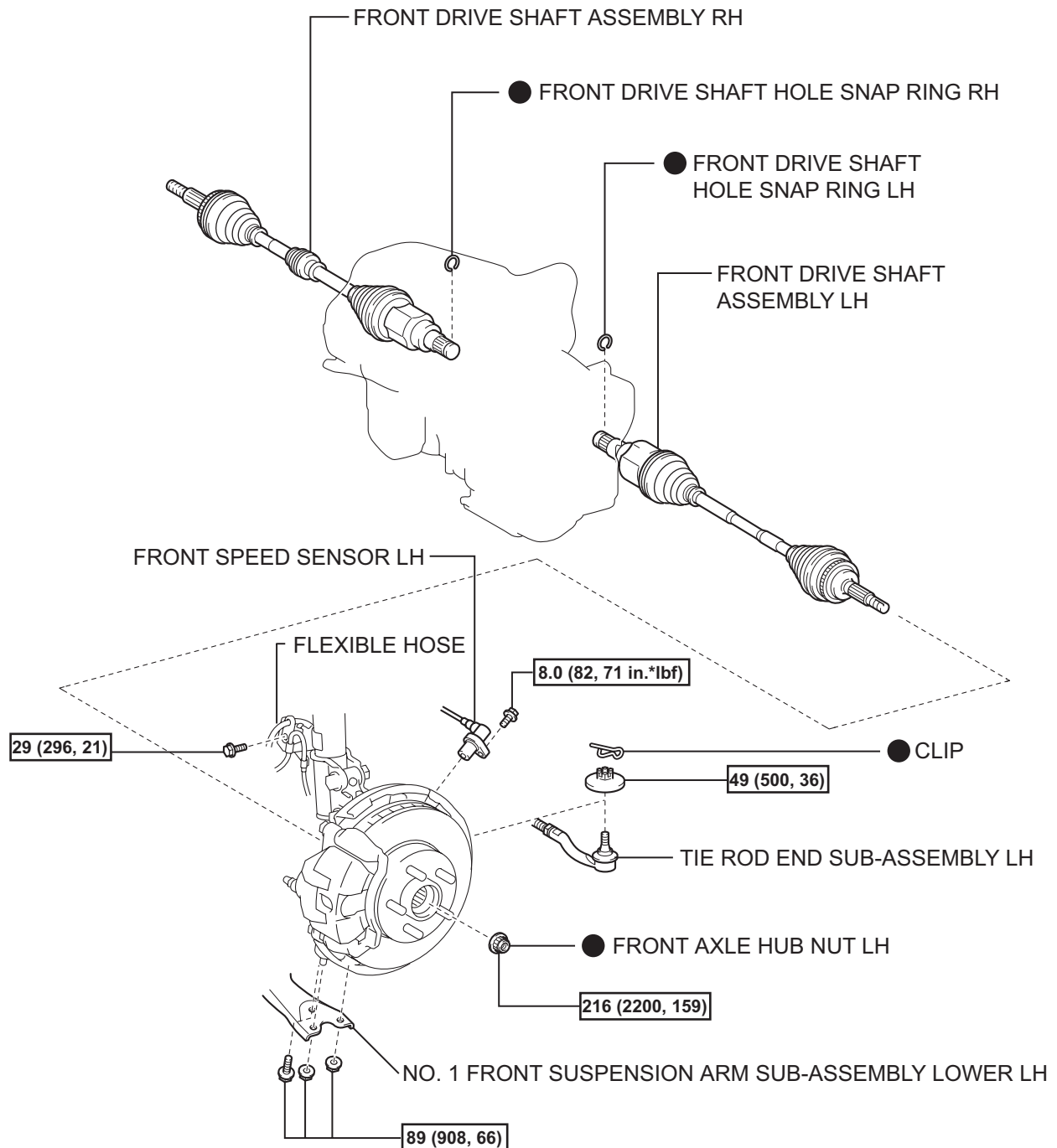

N\*m (kgf\*cm, ft.\*lbf) : Specified torque

● Non-reusable part

DS

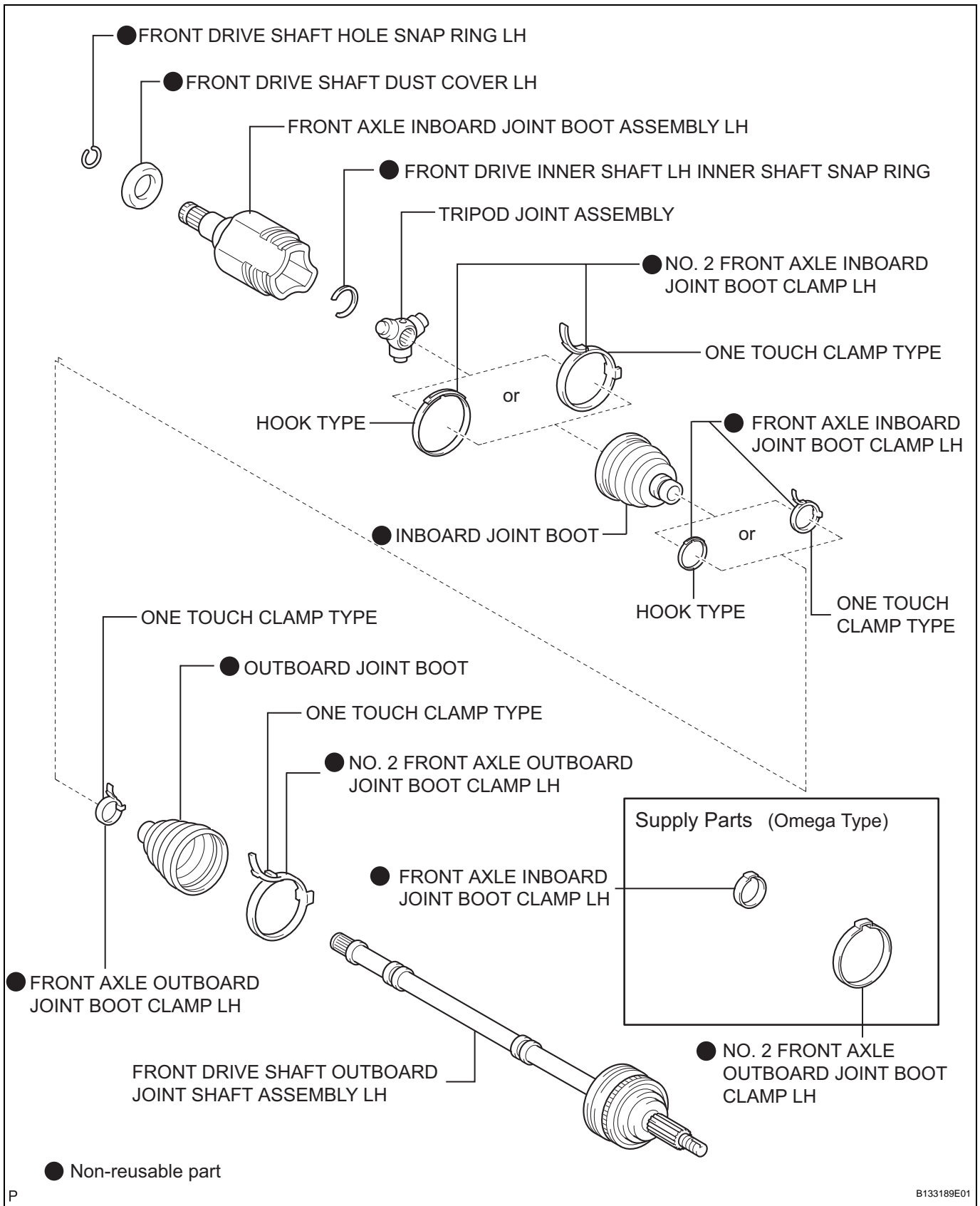

DS

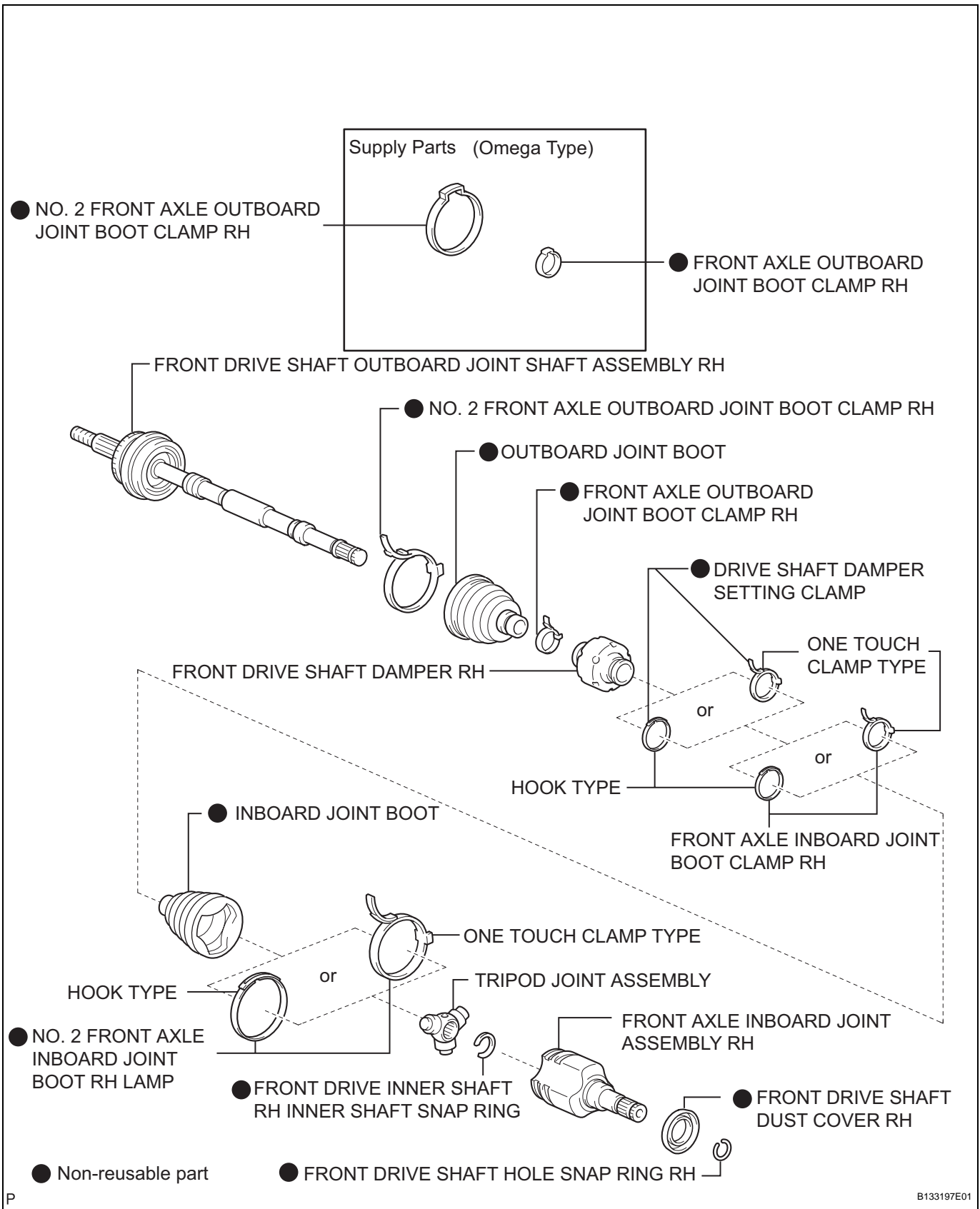

DS

P

## REMOVAL

### HINT:

- Use the same procedures for the RH side and LH side.
- The procedures listed below are for the LH side.

#### 1. DRAIN TRANSAXLE OIL

- Using a 10 mm socket hexagon wrench, remove the drain plug and gasket, and drain the fluid.
- Using a socket hexagon wrench, tighten the drain plug with a new gasket placed inside.  
**Torque: 39 N\*m (400 kgf\*cm, 29 ft.\*lbf)**

#### 2. REMOVE FRONT WHEEL

#### 3. REMOVE FRONT AXLE HUB NUT LH

- Using SST and a hammer, unstake the axle hub nut.  
**SST 09930-00010**

### NOTICE:

- Place SST on the flat part of the nut's recess.
- Do not grind the SST tip with a grinder or equivalent.
- Unstake the front axle hub nut completely when removing it.
- Do not damage the front drive shaft LH threads.

- Using a 30 mm socket wrench, remove the axle hub nut.

#### 4. REMOVE FRONT SPEED SENSOR LH

- Remove the bolt and disconnect the speed sensor wire and flexible hose clamp from the shock absorber.

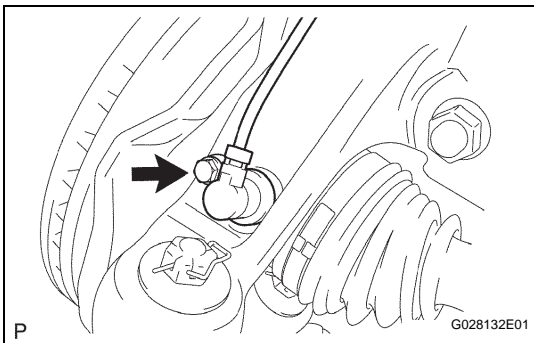
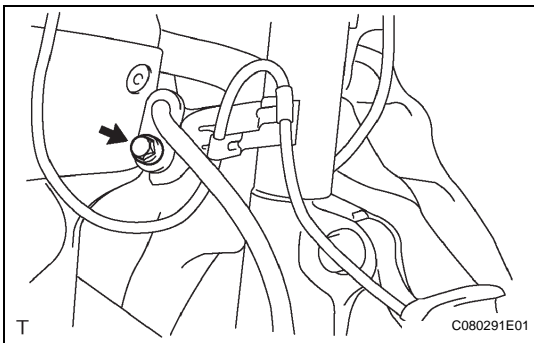
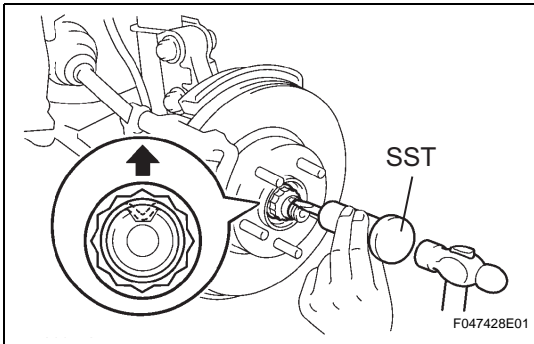

- Remove the bolt and front speed sensor from the steering knuckle.

### NOTICE:

- Keep both the tip and installation part of the speed sensor free of foreign matter.

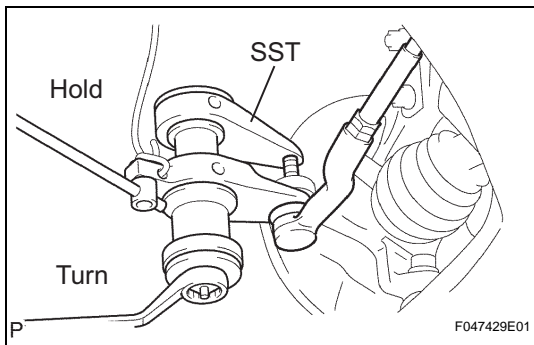

#### 5. DISCONNECT TIE ROD END SUB-ASSEMBLY LH

- (a) Remove the clip and castle nut.
- (b) Using SST, disconnect the tie rod end from the steering knuckle.

**SST 09628-00011**

#### NOTICE:

- Do not damage the front disc brake dust cover.
- Be sure to hang the tie rod end with a string to prevent SST from dropping.
- Do not damage the ball joint dust cover.
- Do not damage the steering knuckle.
- Securely hang SST to the spacer of the steering knuckle.
- Replace the steering knuckle with a new one if the spacer comes off the steering knuckle.

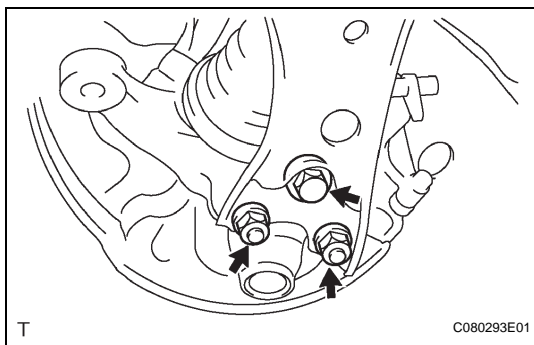

#### 6. DISCONNECT NO. 1 FRONT SUSPENSION ARM SUB-ASSEMBLY LOWER LH

- (a) Remove the bolt and 2 nuts.
- (b) Push down the No. 1 front suspension lower arm and disconnect the front lower ball joint.

#### 7. REMOVE FRONT AXLE ASSEMBLY LH

- (a) Using a plastic-faced hammer, tap the end of the front drive shaft and disengage the fitting between the front drive shaft and front axle.

#### HINT:

If it is difficult to disengage, tap the end of the front drive shaft LH with a brass bar and hammer.

- (b) Push the front axle outward from the vehicle to remove the front drive shaft from the front axle.

#### NOTICE:

- Be careful not to push the front axle outward from the vehicle more than necessary to remove it.
- Be careful not to damage the front axle outboard joint boot.
- Be careful not to damage the speed sensor rotor.
- Hang the drive shaft down with a string or equivalent.

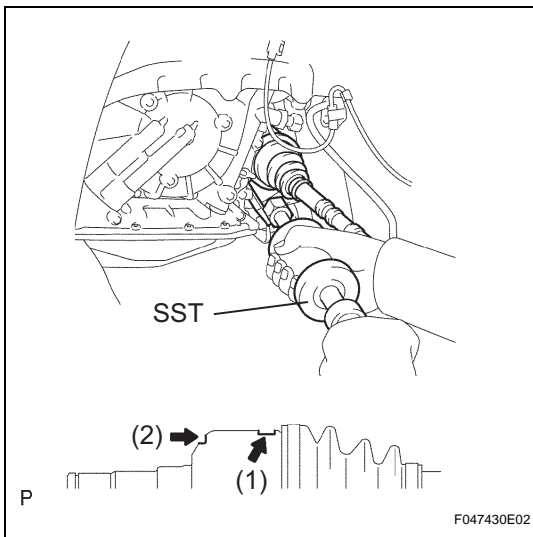
**8. REMOVE FRONT DRIVE SHAFT ASSEMBLY LH**

- (a) Remove the front fender apron seal.
- (b) Hook the SST claw at position (1) in the illustration to remove the front drive shaft.

**SST 09520-01010, 09520-24010 (09520-32040)**

**NOTICE:**

- Be careful not to damage the oil seal.
- Be careful not to damage the front drive shaft boot.
- Be careful not to drop the front drive shaft.

**HINT:**

If the front drive shaft cannot be removed at position (1) in the illustration, hook the SST claw at position (2) in the illustration in order to remove it.

**9. REMOVE FRONT DRIVE SHAFT ASSEMBLY RH****HINT:**

Remove the front drive shaft RH following the same procedures as the LH side.

**10. FIX FRONT AXLE ASSEMBLY LH****HINT:**

The hub bearing could be damaged if it is subjected to the vehicle's full weight, such as when moving the vehicle with the drive shaft removed. If it is absolutely necessary to place the vehicle's weight on the hub bearing, first support it with SST.

**SST 09608-16042 (09608-02021, 09608-02041)**

**11. INSPECT FRONT DRIVE SHAFT ASSEMBLY LH**

- (a) Check for noticeable looseness when turning the joint up and down, left and right, and in the thrust direction.
- (b) Check for cracks, damage or grease leaks on the joint boot.

**NOTICE:**

**Carry the drive shaft levelly.**

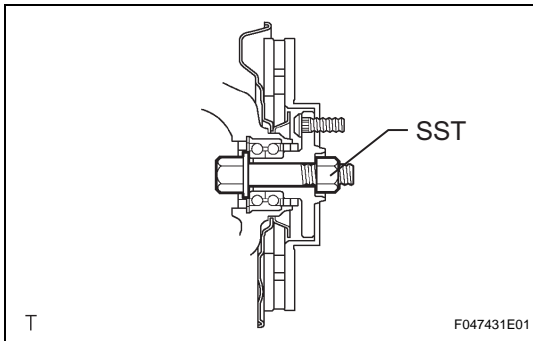

## DISASSEMBLY

### HINT:

- Use the same procedures for the RH side and LH side.
- The procedures listed below are for the LH side.

### 1. REMOVE NO. 2 FRONT AXLE INBOARD JOINT BOOT CLAMP LH

- (a) When using a one touch clamp:  
Using a flat-head screwdriver, unhook the No. 2 inboard joint boot clamp and separate the No. 2 inboard joint boot clamp.

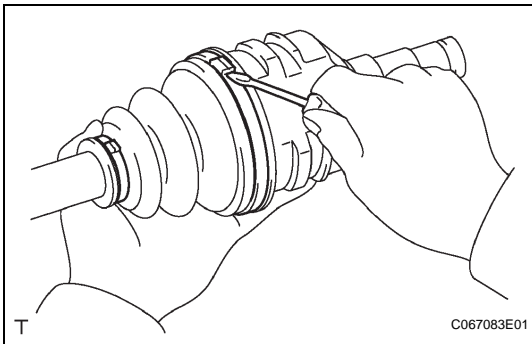

- (b) When using a hook type:  
Using needle-nose pliers, unhook and remove the No. 2 inboard joint boot clamp.

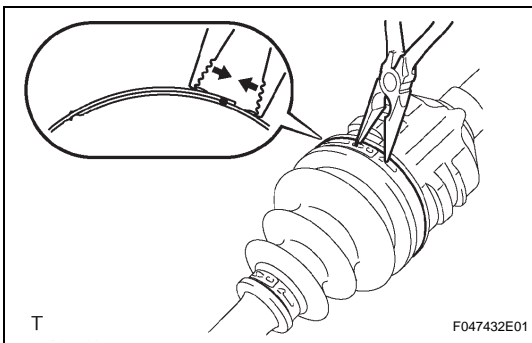

### 2. REMOVE FRONT AXLE INBOARD JOINT BOOT LH CLAMP

- (a) When using a one touch clamp:  
Using a flat-head screwdriver, separate the inboard joint boot clamp and separate the inboard joint boot clamp.

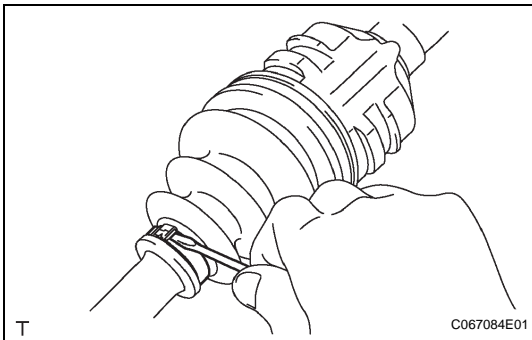

- (b) When using a hook type:  
Using needle-nose pliers, unhook and remove the inboard joint boot clamp.

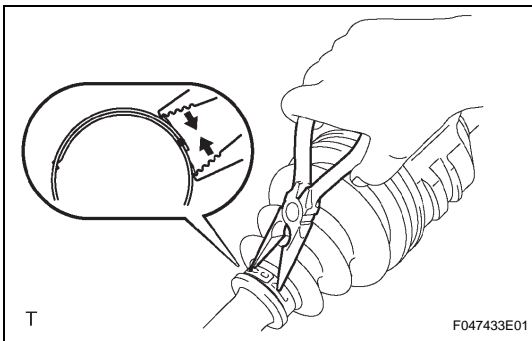

### 3. DISCONNECT FRONT AXLE INBOARD JOINT BOOT

- (a) Disconnect the inboard joint boot from the inboard joint.

### 4. REMOVE FRONT DRIVE INBOARD JOINT ASSEMBLY LH

- (a) Remove grease from the inboard joint.



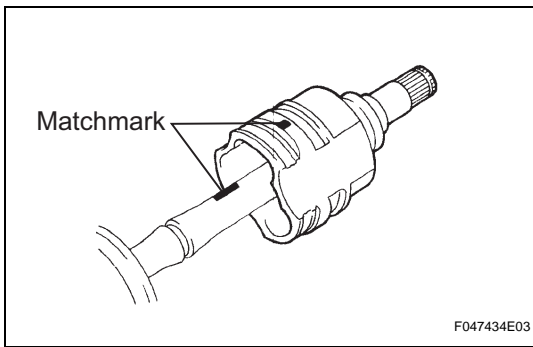

- (b) Put matchmarks on the inboard joint and outboard joint.

**NOTICE:**

**Do not make matchmarks with a punch and hammer.**

- (c) Remove the inboard joint from the outboard joint.
- (d) Hold the outboard joint with vise aluminum plates in between.

**NOTICE:**

**Do not overtighten the vise.**

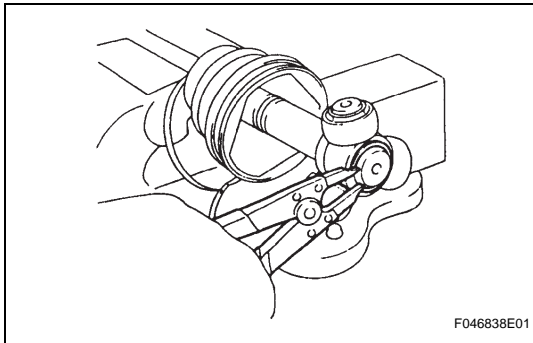

- (e) Using a snap ring expander, remove the front drive inner shaft snap ring.

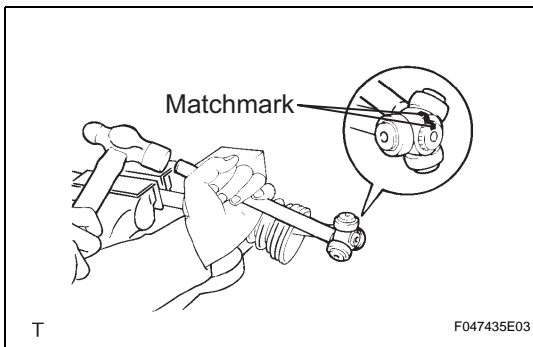

- (f) Put matchmarks on the tripod joint and outboard joint.

**NOTICE:**

**Do not make matchmarks with a punch and hammer.**

- (g) Using a brass bar and hammer, tap out the tripod joint.

**NOTICE:**

**Do not hit the roller position.**

- (h) Remove the No. 2 inboard joint boot clamp, inboard joint boot and inboard joint boot clamp.

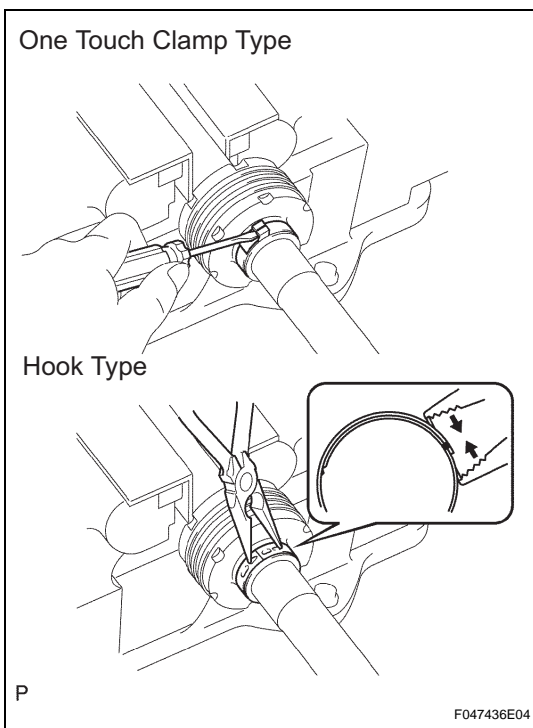

**5. REMOVE DRIVE SHAFT DAMPER SETTING CLAMP**  
HINT:

Perform this procedure only when overhauling the RH side.

- (a) When using a one touch clamp:  
Using a flat-head screwdriver, remove the drive shaft damper clamp.
- (b) When using a hook type:  
Using needle-nose pliers, unhook and remove the drive shaft damper clamp.
- (c) Remove the drive shaft damper from the outboard joint LH.

**6. REMOVE FRONT DRIVE SHAFT DAMPER RH**

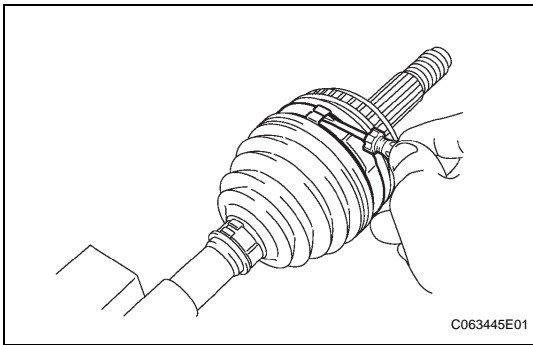

**7. REMOVE NO. 2 FRONT AXLE OUTBOARD JOINT BOOT CLAMP LH**

- (a) Using a flat-head screwdriver, remove the No. 2 outboard joint boot clamp.

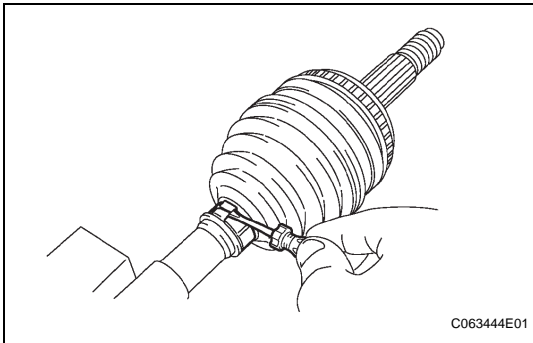

**8. REMOVE FRONT AXLE OUTBOARD JOINT BOOT CLAMP LH**

- (a) Using a flat-head screwdriver, remove the outboard joint boot clamp.

**9. REMOVE OUTBOARD JOINT BOOT**

- (a) Remove the outboard joint boot from the outboard joint LH.  
 (b) Remove grease from the outboard joint.

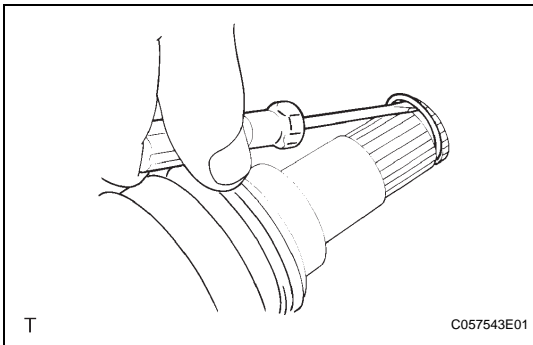

**10. REMOVE FRONT DRIVE SHAFT HOLE SNAP RING LH**

- (a) Using a flat-head screwdriver, remove the front drive shaft hole snap ring.

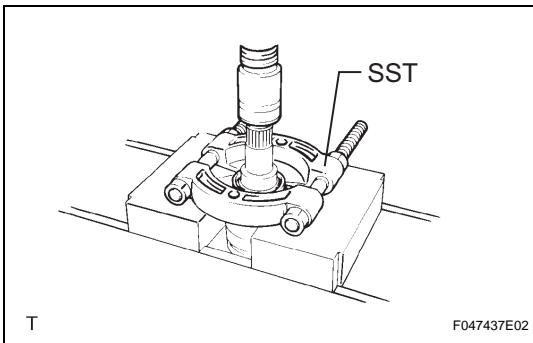

**11. REMOVE FRONT DRIVE SHAFT DUST COVER LH**

- (a) Using SST and a press, press out the front drive shaft dust cover.

**SST 09950-00020**

**NOTICE:**

**Be careful not to drop the inboard joint.**

**12. REMOVE FRONT DRIVE SHAFT DUST COVER RH**

**HINT:**

Remove the front drive shaft dust cover RH following the same procedures as the LH side.

**SST 09950-00020**

## REASSEMBLY

### HINT:

- Use the same procedures for the RH side and LH side.
- The procedures listed below are for the LH side.

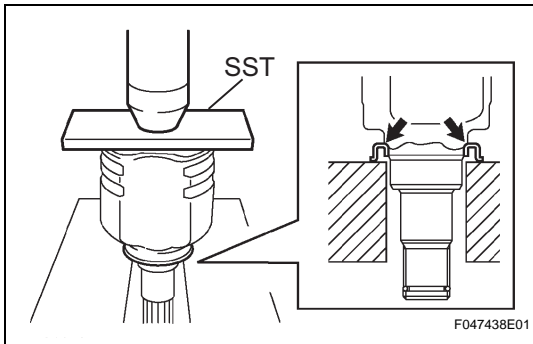

### 1. INSTALL FRONT DRIVE SHAFT DUST COVER LH

- Using SST and a press, install a new front drive shaft dust cover and press it in until it contacts the end of the inboard joint.

**SST 09527-10011**

#### NOTICE:

- Install the front driver shaft dust cover LH in the correct direction.
- Do not deform the front drive shaft dust cover LH.

### 2. INSTALL FRONT DRIVE SHAFT DUST COVER RH

#### HINT:

Install the front drive shaft dust cover RH following the same procedures as the LH side.

**SST 09527-10011**

### 3. INSTALL FRONT DRIVE SHAFT HOLE SNAP RING LH

- Install a new front drive shaft hole snap ring.

### 4. INSTALL OUTBOARD JOINT BOOT

- Wrap protective tape around the spline of the outboard joint.
- Install the following new parts on the outboard joint LH in order.
  - No. 2 outboard joint boot clamp LH
  - Outboard joint boot
  - Outboard joint boot clamp LH
- Apply grease to the joint of the outboard joint LH and outboard joint boot.

#### Standard capacity:

**125 to 135 g (4.9 to 5.3 oz.)**

- Install the outboard joint boot into the outboard joint groove.

#### NOTICE:

**Do not apply grease in the groove.**

### 5. INSTALL NO. 2 FRONT AXLE OUTBOARD JOINT BOOT CLAMP LH

- Hold the front drive shaft in a vise between 2 aluminum plates.

#### NOTICE:

**Do not overtighten the vise.**

- Set SST to the No. 2 outboard joint boot clamp and slightly tighten the SST bolt while pushing the outboard joint on.

**SST 09521-24010**

- Hold SST and tighten the SST bolt so that the clearance is within the specified value.

#### Standard clearance:

**0.8 mm (0.031 in.) or less**

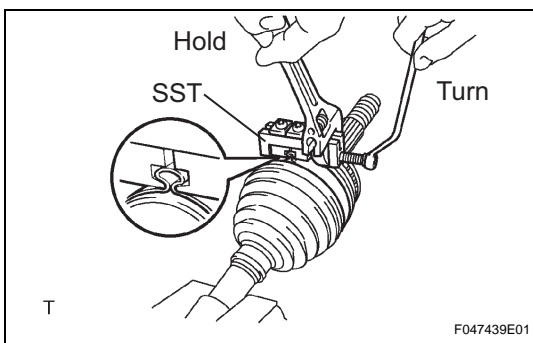

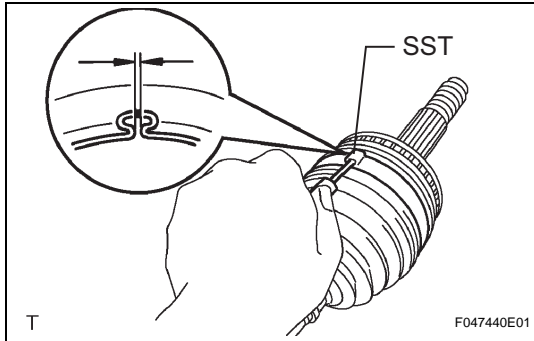
**NOTICE:**

**Do not damage the outboard joint.**

- (d) Remove SST.
- (e) Using SST, measure the clearance of the No. 2 outboard joint boot clamp LH.

**SST 09240-00020**

**Standard clearance:**

**0.8 mm (0.031 in.) or less**

**NOTICE:**

**If the clearance exceeds the maximum, retighten it.**

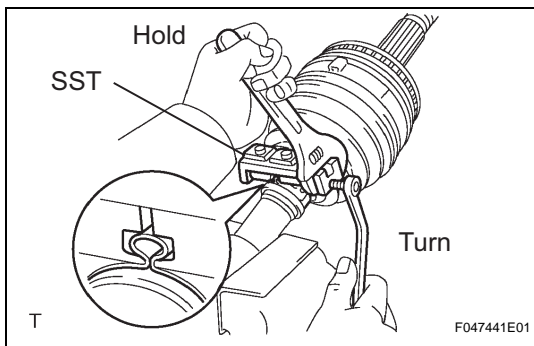

### 6. INSTALL FRONT AXLE OUTBOARD JOINT BOOT CLAMP LH

- (a) Set SST to the outboard joint boot clamp LH and slightly tighten the SST bolt while pushing the outboard joint on.
- (b) Hold SST and tighten the SST bolt so that the clearance is within the specified value.

**SST 09521-24010**

**Standard clearance:**

**0.8 mm (0.031 in.) or less**

**NOTICE:**

**Do not damage the outboard joint.**

- (c) Remove SST.
- (d) Using SST, measure the clearance of the outboard joint boot clamp LH.

**SST 09240-00020**

**Standard clearance:**

**0.8 mm (0.031 in.) or less**

**NOTICE:**

**If the clearance exceeds the maximum, retighten it.**

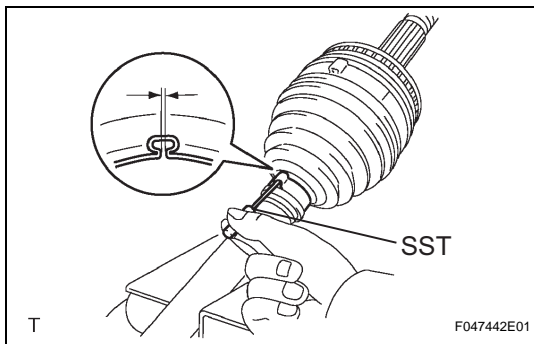

### 7. INSTALL FRONT DRIVE SHAFT DAMPER RH

**HINT:**

- Use the same procedures for the RH side and LH side.
- The procedures listed below are for the LH side.

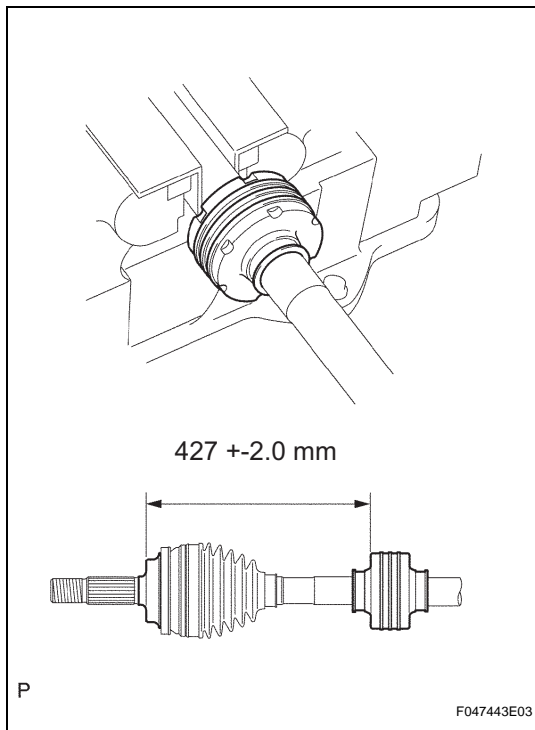

- (a) Install the drive shaft damper to the outboard joint LH.

**Standard distance:**

**427 +/-2.0 mm (16.81 +/-0.079 in.)**

**NOTICE:**

**Install in the correct direction.**

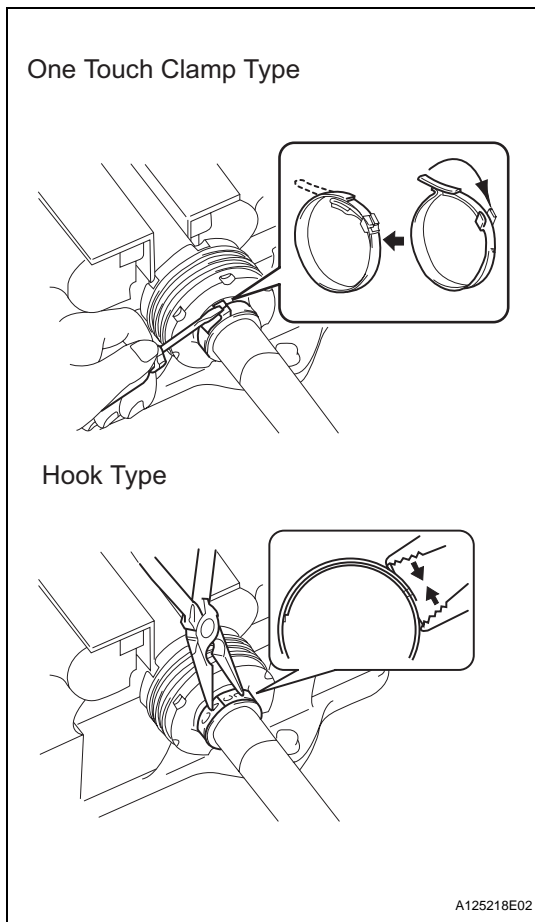

## 8. INSTALL DRIVE SHAFT DAMPER SETTING CLAMP

- (a) When using a one touch clamp:  
Install the drive shaft damper clamp to the drive shaft damper and stake the drive shaft damper clamp using a flat-head screwdriver.
- (b) When using a hook type:  
Using needle-nose pliers, align the concave part and protrusion of the drive shaft damper clamp in order to lock it.

## 9. INSTALL FRONT DRIVE INBOARD JOINT ASSEMBLY LH

- (a) Install the following new parts on the outboard joint LH in order.
- (1) Inboard joint boot clamp
  - (2) Inboard joint boot
  - (3) No. 2 inboard joint boot clamp
- (b) Hold the drive shaft in a vise between 2 aluminum plates.
- NOTICE:**  
**Do not overtighten the vise.**
- (c) Remove the protective tape.

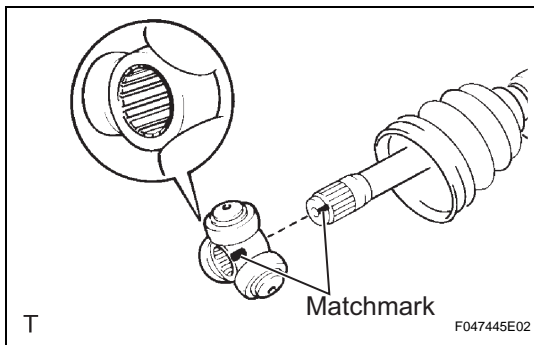

- (d) Align the matchmarks and install the tripod joint onto the outboard joint.

**NOTICE:**

**Face the serration side of the tripod joint outward and install it to the outboard joint end.**

- (e) Using a brass bar and hammer, drive the tripod joint in.

**NOTICE:**

- Do not hit the roller portion.
- Do not attach any foreign matter on the tripod joint.

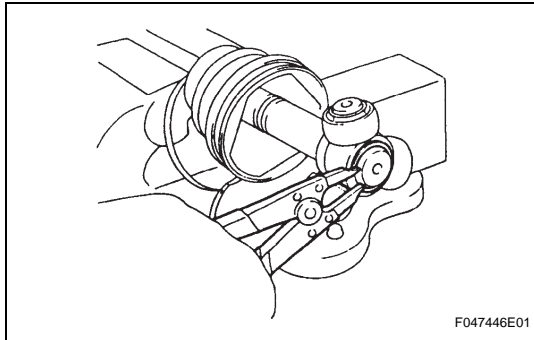

- (f) Using a snap ring expander, install a new front drive inner shaft snap ring.

- (g) Fill grease in the joint of the inboard joint and outboard joint boot.

**Standard capacity:**

**125 to 135 g (4.9 to 5.3 oz.)**

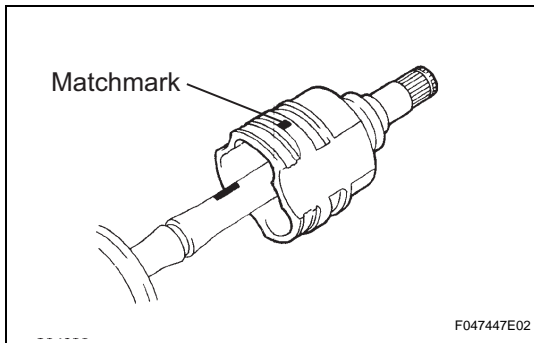

- (h) Align the matchmarks and install the inboard joint onto the outboard joint.

**10. INSTALL FRONT AXLE INBOARD JOINT BOOT**

- (a) Install the inboard joint boot into the inboard joint LH and outboard joint LH grooves.

**NOTICE:**

**Do not apply grease in the groove.**

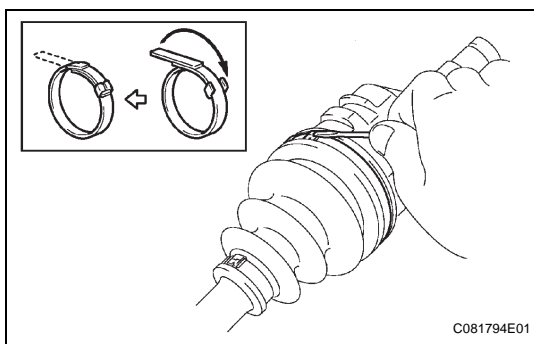
**11. INSTALL NO. 2 FRONT AXLE INBOARD JOINT BOOT CLAMP LH**

- (a) When using a one touch clamp:

Install the No. 2 inboard joint boot clamp LH to the inboard joint boot and stake the No. 2 inboard joint boot clamp LH using a flat-head screwdriver.

**NOTICE:**

**Do not scratch the inboard joint boot.**

- (b) When using a hook type:

Using needle-nose pliers, align the concave part with the protrusion of the No. 2 inboard joint boot clamp LH in order to lock it.

**NOTICE:**

- Do not scratch the inboard joint boot.
- Do not deform the claw of the hook.

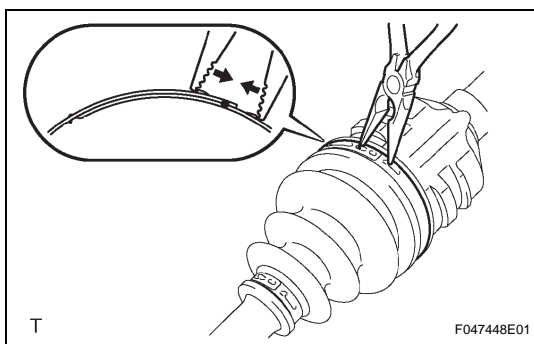

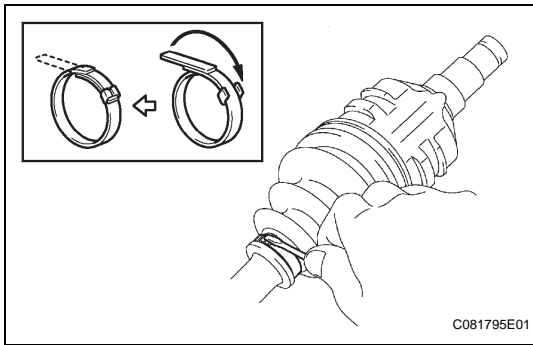

## 12. INSTALL FRONT AXLE INBOARD JOINT BOOT CLAMP LH

- (a) When using a one touch clamp:  
Install the inboard joint boot clamp to the inboard joint boot and stake the inboard joint boot clamp using a flat-head screwdriver.

**NOTICE:**

**Do not scratch the inboard joint boot.**

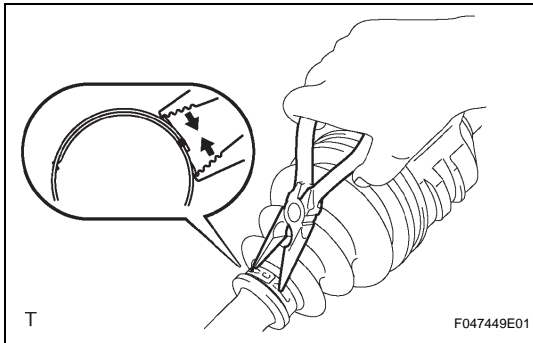

- (b) When using a hook type:  
Using needle-nose pliers, align the concave part with the protrusion of the No. 2 inboard joint boot clamp in order to lock it.

**NOTICE:**

- Do not scratch the inboard joint boot.
- Do not deform the claw of the hook.

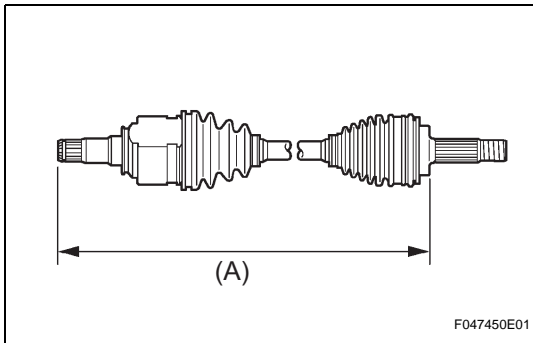

## 13. INSPECT FRONT DRIVE SHAFT ASSEMBLY LH

- (a) Check if the front drive shaft is within the following dimension.

**Standard dimension (A)**

LH	RH
564.3 mm (22.216 in.)	846.3 mm (33.319 in.)

- (b) Check for noticeable looseness when turning the joint up and down, left and right, and in the thrust direction.
- (c) Check for cracks, damage or grease leaks on the joint boot.

**NOTICE:**

**Carry the front drive shaft LH levelly.**

## INSTALLATION

### HINT:

- Use the same procedures for the RH side and LH side.
- The procedures listed below are for the LH side.

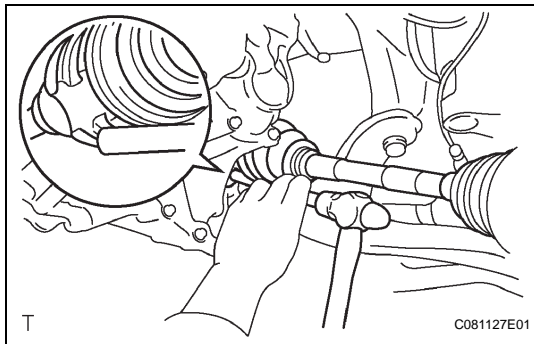

### 1. INSTALL FRONT DRIVE SHAFT ASSEMBLY LH

- Apply ATF to the spline of the inboard joint.
- Align the spline of the front drive shaft and insert the front drive shaft using a brass bar and hammer.

#### NOTICE:

- Face the snap ring cut area downward.
- Be careful not to damage the oil seal.
- Be careful not to damage the front drive shaft boot.

#### HINT:

Judge whether the front drive shaft is securely driven in or not according to the brass bar reaction force or sound change.

- Install the front fender apron seal.

### 2. INSTALL FRONT DRIVE SHAFT ASSEMBLY RH

#### HINT:

Install the front drive shaft dust cover RH following the same procedures as the LH side.

### 3. INSTALL FRONT AXLE ASSEMBLY LH

- Push the front axle outward from the vehicle to align the spline of the front drive shaft with the front axle and insert.

#### NOTICE:

- Be careful not to push the front axle outward from the vehicle more than necessary to remove it.
- Be careful not to damage the oil seal.
- Be careful not to damage the front drive shaft LH boot.
- Be careful not to damage the speed sensor rotor.
- Check for any foreign matter on the speed sensor rotor and insertion part.

### 4. CONNECT NO. 1 FRONT SUSPENSION ARM SUB-ASSEMBLY LOWER LH

- Push the No. 1 front suspension lower arm downward, install the front lower ball joint and tighten the bolt and 2 nuts.

**Torque: 89 N\*m (908 kgf\*cm, 66 ft.\*lbf)**

### 5. CONNECT TIE ROD END SUB-ASSEMBLY LH

- Connect the tie rod end to the steering knuckle and install it with the castle nut.

#### NOTICE:

The clip hole alignment should be done after tightening the castle nut up to 60° beyond the torque specification.

**Torque: 49 N\*m (500 kgf\*cm, 36 ft.\*lbf)**

- Install a new clip.

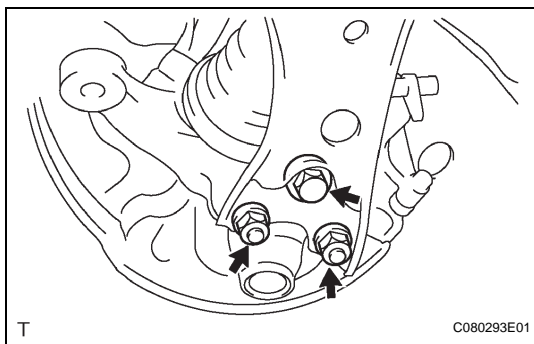



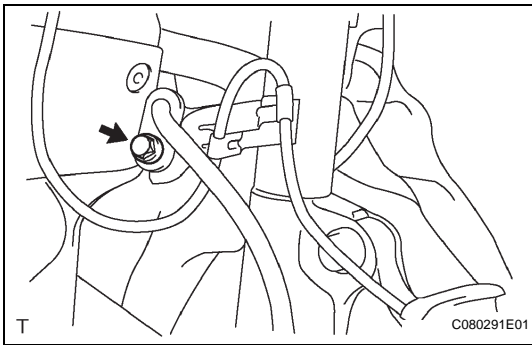

## 6. INSTALL FRONT SPEED SENSOR LH

- (a) Connect the front speed sensor wire and flexible hose clamp to the shock absorber with the bolt.  
**Torque: 29 N\*m (296 kgf\*cm, 21 ft.\*lbf)**

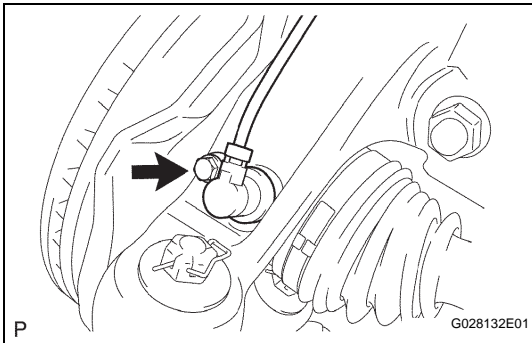

- (b) Install the front speed sensor to the steering knuckle.

**Torque: 8.0 N\*m (82 kgf\*cm, 71 in.\*lbf)**

### NOTICE:

- Do not damage the speed sensor tip when installing the speed sensor.
- Ensure no foreign object is caught when tightening the bolt.
- Do not twist the sensor wire when installing the speed sensor.

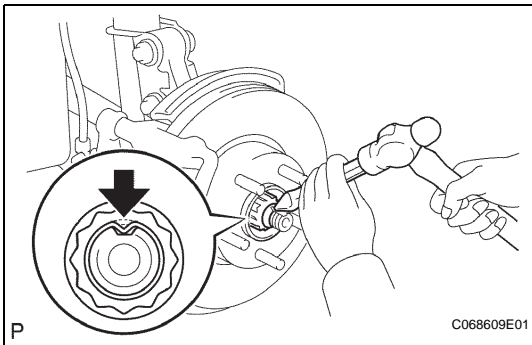

## 7. INSTALL FRONT AXLE HUB NUT LH

- (a) Using a 30 mm socket wrench, install a new hub nut.

**Torque: 216 N\*m (2,200 kgf\*cm, 159 ft.\*lbf)**

- (b) Using a chisel and hammer, stake the hub nut.

## 8. INSTALL FRONT WHEEL

**Torque: 103 N\*m (1,050 kgf\*cm, 76 ft.\*lbf)**

## 9. ADD TRANSAXLE OIL

## 10. INSPECT TRANSAXLE OIL (See page [HX-130](#))

## 11. INSPECT AND ADJUST FRONT WHEEL ALIGNMENT (See page [SP-3](#))

## 12. CHECK ABS SPEED SENSOR SIGNAL (See page [BC-219](#))