

HYBRID CONTROL SYSTEM

PRECAUTION

1. PRECAUTIONS FOR INSPECTING THE HYBRID CONTROL SYSTEM

- (a) Before inspecting the high-voltage system, take safety precautions to prevent electrical shocks, such as wearing insulated gloves and removing the service plug grip (see page IN-5). After removing the service plug grip, put it in your pocket to prevent other technicians from reconnecting it while you are servicing the high-voltage system.

NOTICE:

Turning the power switch ON (READY) with the service plug grip removed could cause a malfunction. Therefore, do not turn the power switch ON (READY) unless instructed by the repair manual.

- (b) After disconnecting the service plug grip, wait for at least 5 minutes before touching any of high-voltage connectors or terminals.

HINT:

At least 5 minutes are required to discharge the high-voltage condenser inside the inverter.

- (c) Since liquid leakage may occur, wear protective goggles when checking inside the HV battery.
- (d) Wear insulated gloves, turn the power switch OFF, and disconnect the negative terminal of the auxiliary battery before touching any of the orange-colored wires of the high-voltage system.
- (e) Turn the power switch OFF before performing a resistance check.
- (f) Turn the power switch OFF before disconnecting or reconnecting any connector.

- (g) To install the service plug grip, the lever must be flipped and locked downward. Once it is locked in place, it turns the interlock switch ON. Make sure to lock it securely because if you leave it unlocked, the system will output a DTC pertaining to the interlock switch system.

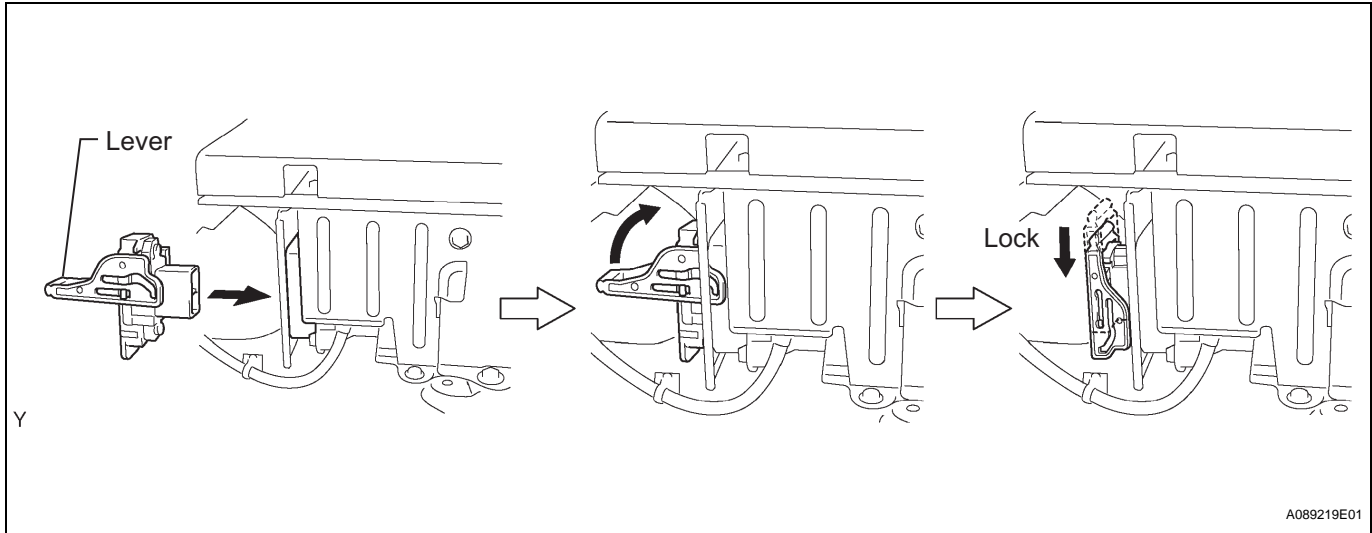

2. NOTICE FOR INITIALIZATION

When disconnecting the cable from the negative (-) battery terminal, initialize the following systems after the cable is reconnected.

System Name	See Procedure
Power Window Control System	IN-32

3. NOTICE FOR HYBRID SYSTEM ACTIVATION

- When the warning light is illuminated or the battery has been disconnected and reconnected, pressing the power switch may not start the system on the first attempt. If so, press the power switch again.
- With the power switch's power mode changed to ON (IG), disconnect the battery. If the key is not in the key slot during reconnection, DTC B2799 may be output.

DEFINITION OF TERMS

1. DEFINITION OF TERMS

Each monitor description follows a standardized format using these terms:

Terms	Definition
Duration	The minimum time that the HV control ECU must sense a continuous deviation in the monitored value(s) before setting a DTC. This timing begins after the "typical enabling conditions" are met.
Frequency of operation	The number of times that the HV control ECU checks for malfunction per driving cycle. "Once per driving cycle" means that the HV control ECU detects malfunction only one time during a single driving cycle. "Continuous" means that the HV control ECU detects malfunction every time when enabling condition is met.
MIL operation	MIL illumination timing after a defect is detected. "Immediately" means that the HV control ECU illuminates the MIL the instant the HV control ECU determines that there is malfunction. "2 driving cycles" means that the HV control ECU illuminates the MIL if the same malfunction is detected again in the 2nd driving cycle.
Monitor description	Description of what the HV control ECU monitors and how it detects malfunction (monitoring purpose and its details).
Related DTCs	A group of DTCs that is classified by a system and a troubleshooting procedure.
Required sensor / components	The sensors and components that are used by the HV control ECU to detect malfunction.
Sequence of operation	The priority order that is applied to monitoring, if multiple sensors and components are used to detect the malfunction. While another sensor is being monitored, the next sensor or component will not be monitored until the previous monitoring has concluded.
Typical enabling condition	Preconditions that allow the HV control ECU to detect malfunction. With all preconditions satisfied, the HV control ECU sets the DTC when the monitored value(s) exceeds the malfunction threshold(s).
Typical malfunction thresholds	Beyond this value, the HV control ECU will conclude that there is malfunction and set a DTC.

PARTS LOCATION

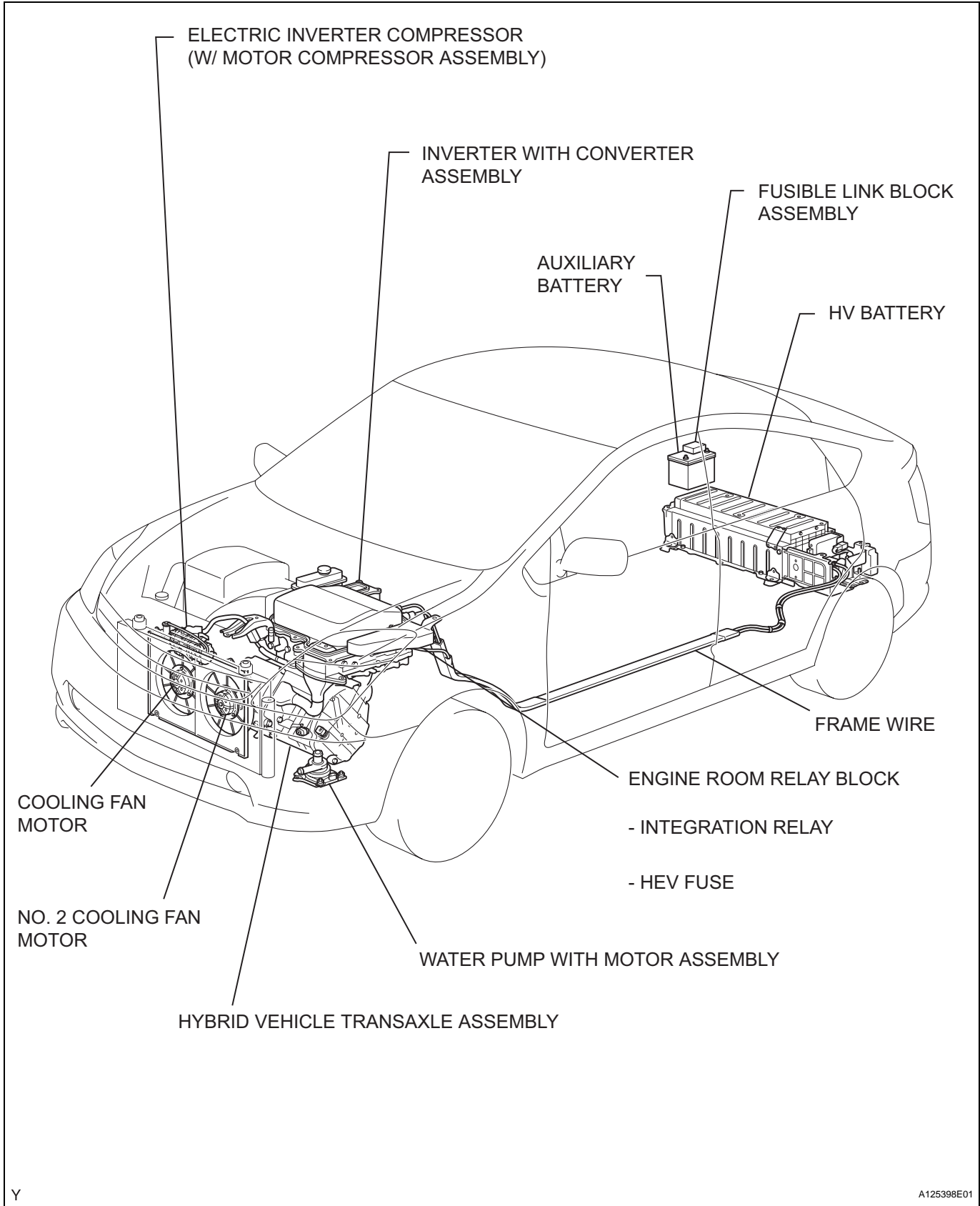

HV

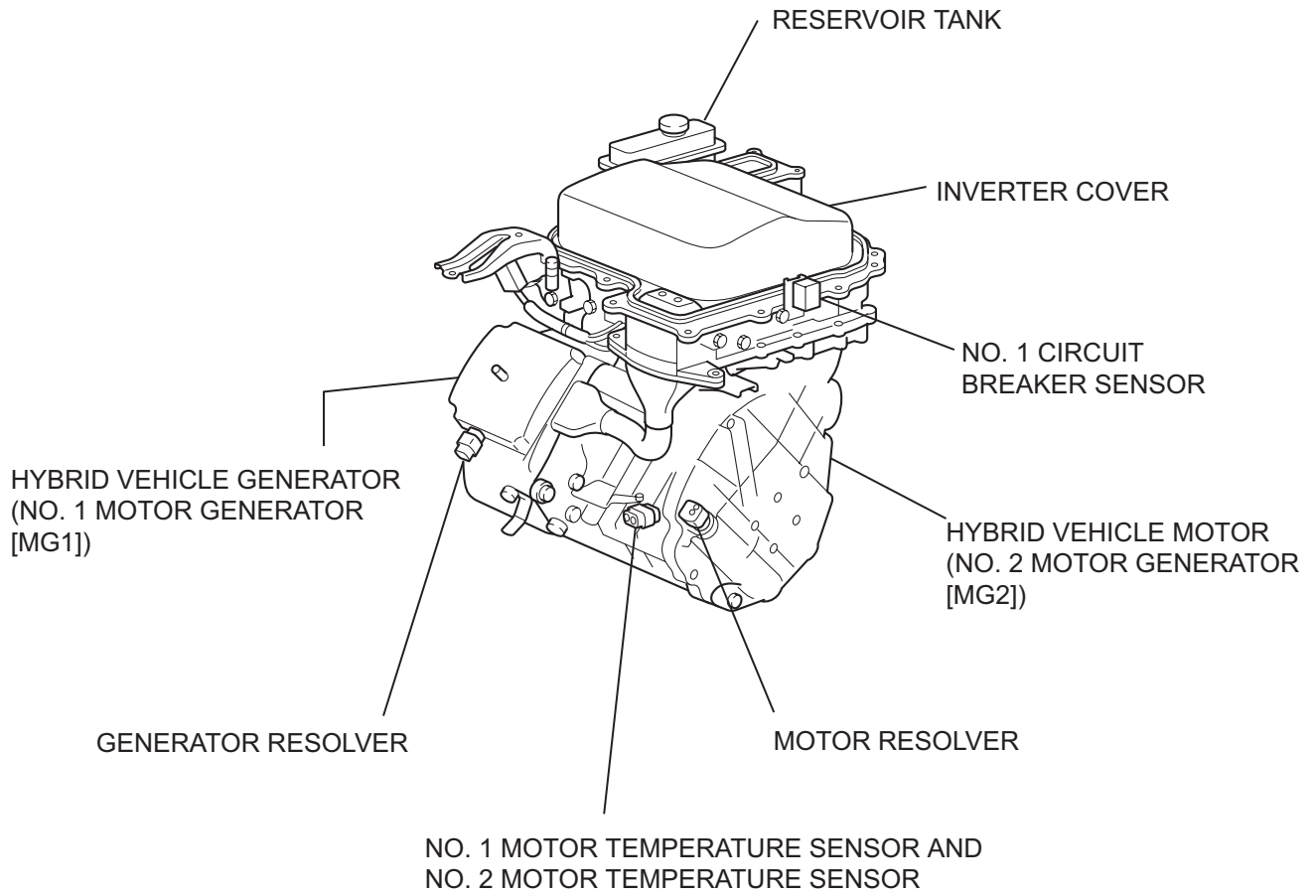

HV

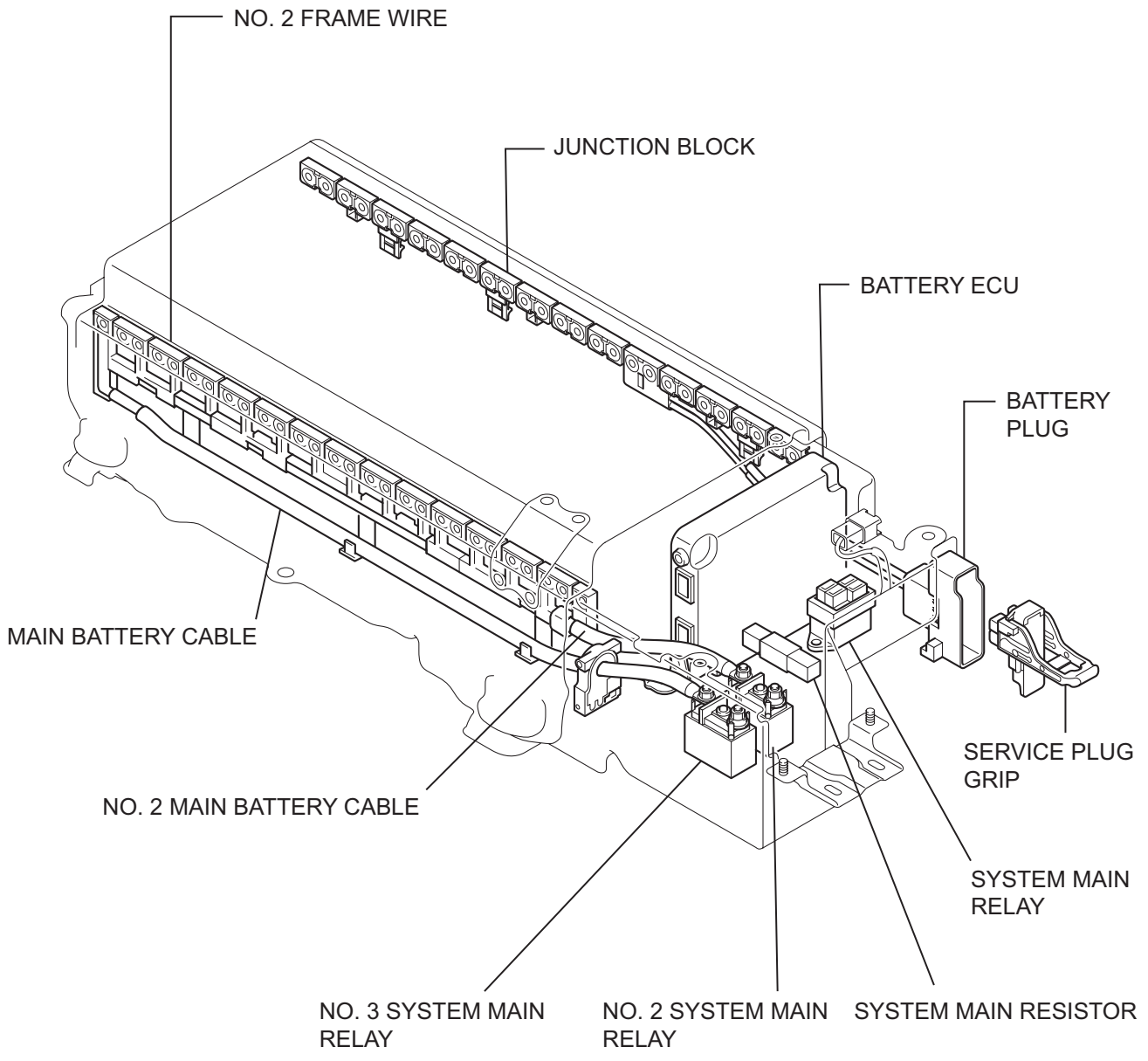

HV

Y

A125400E01

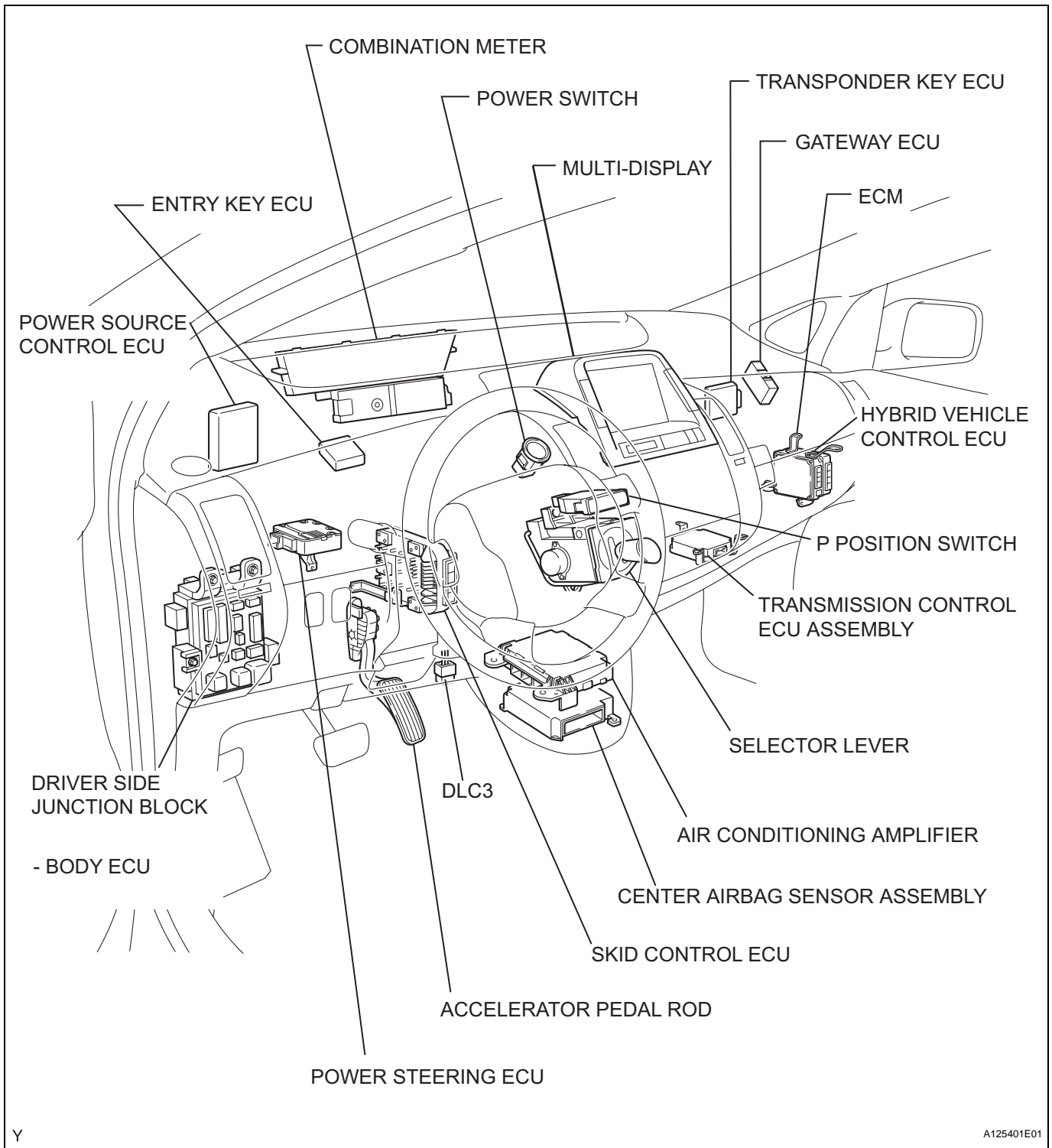

HV

SYSTEM DIAGRAM

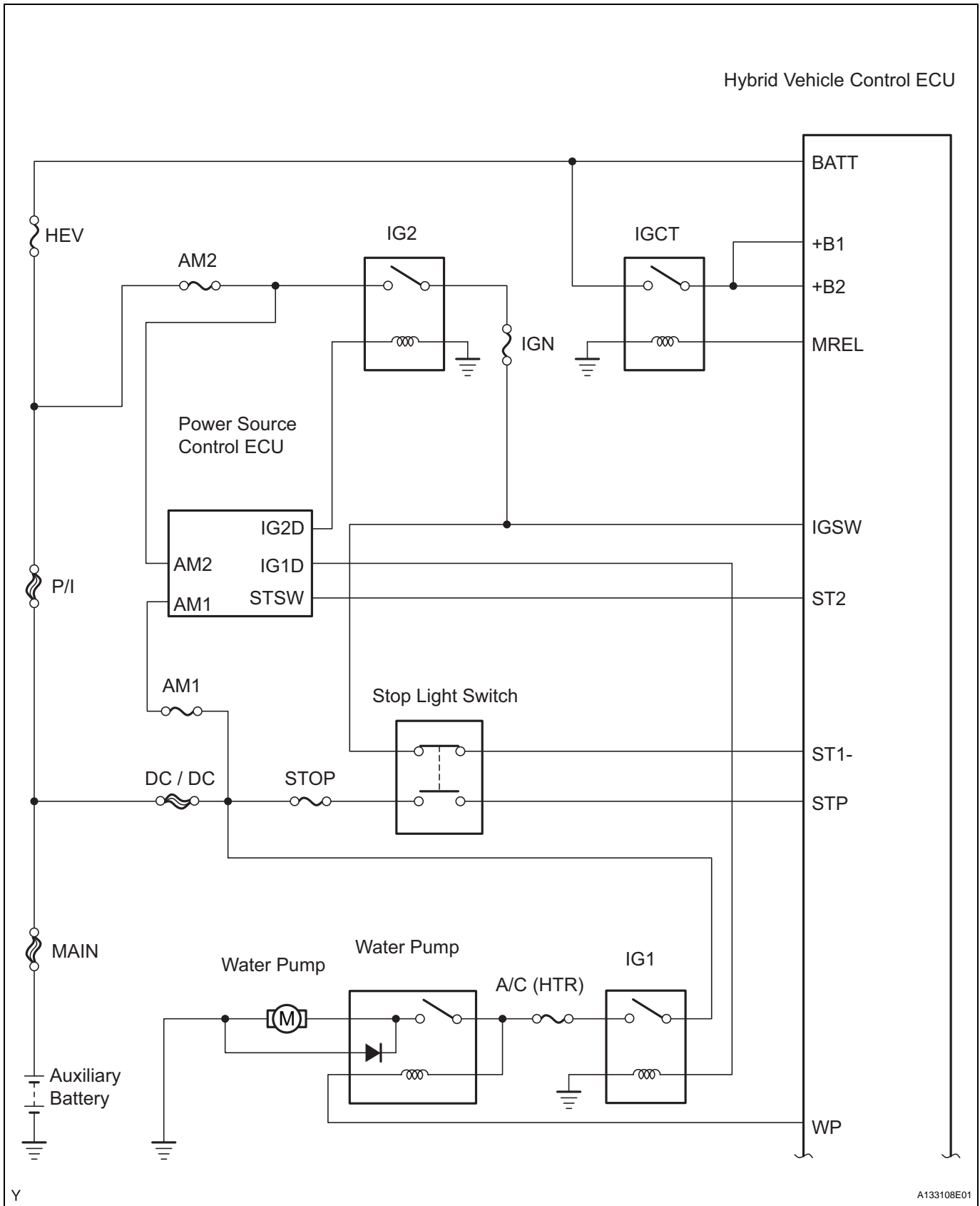

HV

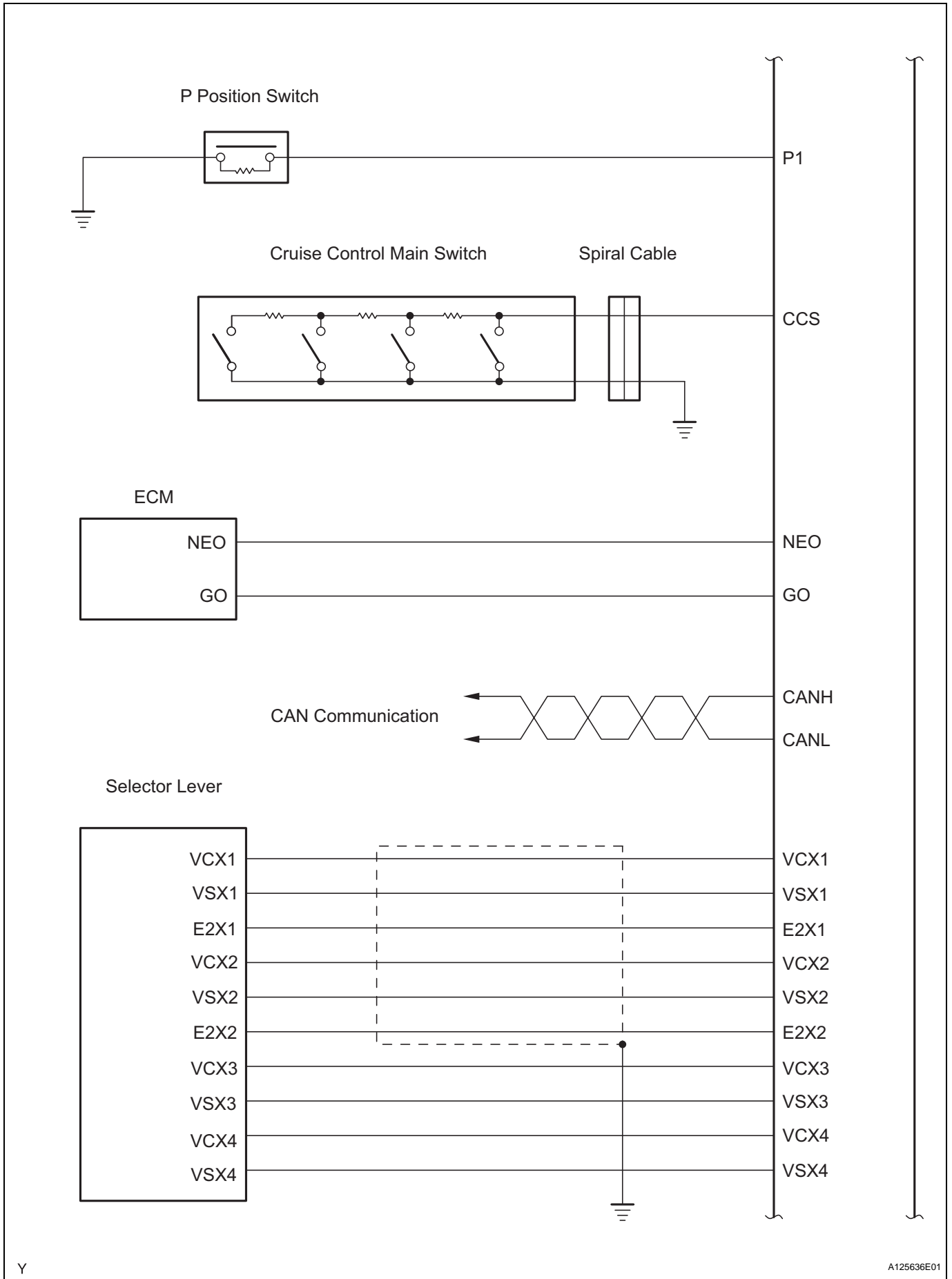

HV

Accelerator Pedal Rod

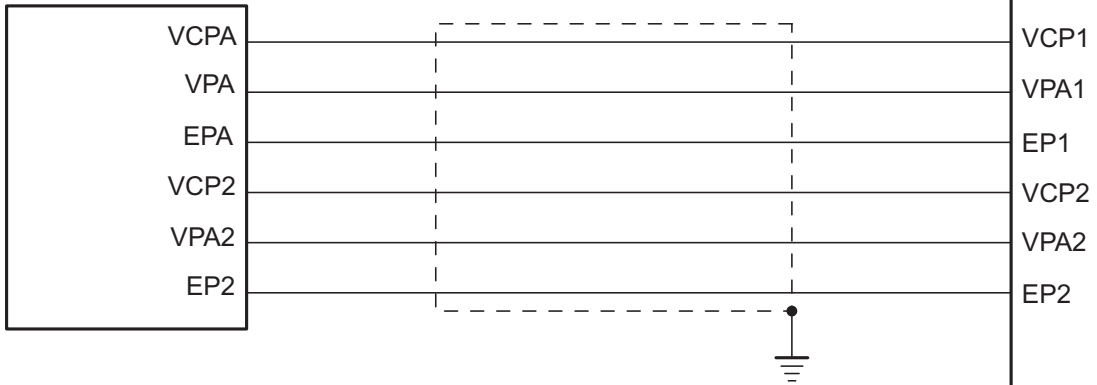

Transmission Control ECU Assembly

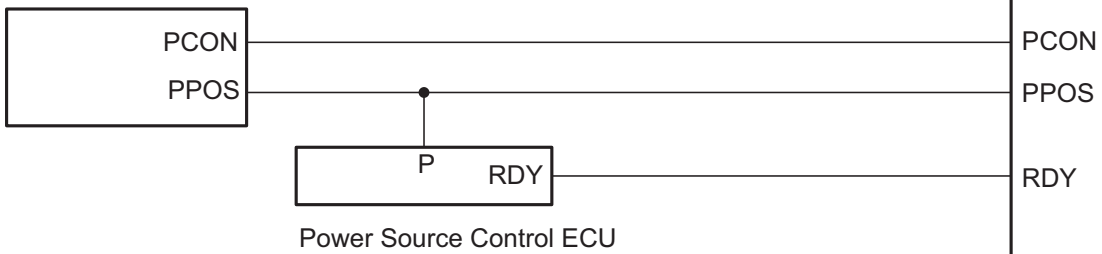

Transponder Key ECU

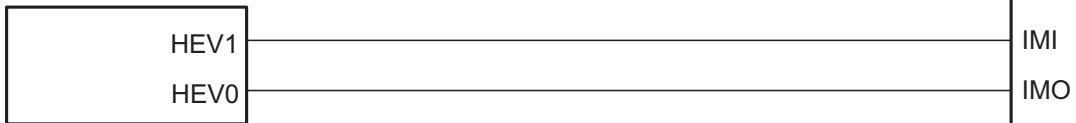

Center Airbag Sensor

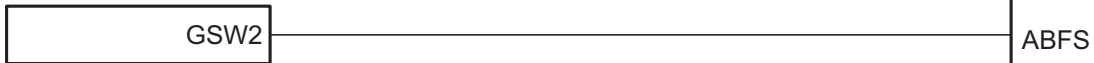

DLC3

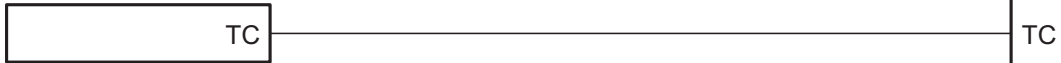

Combination Meter



HV

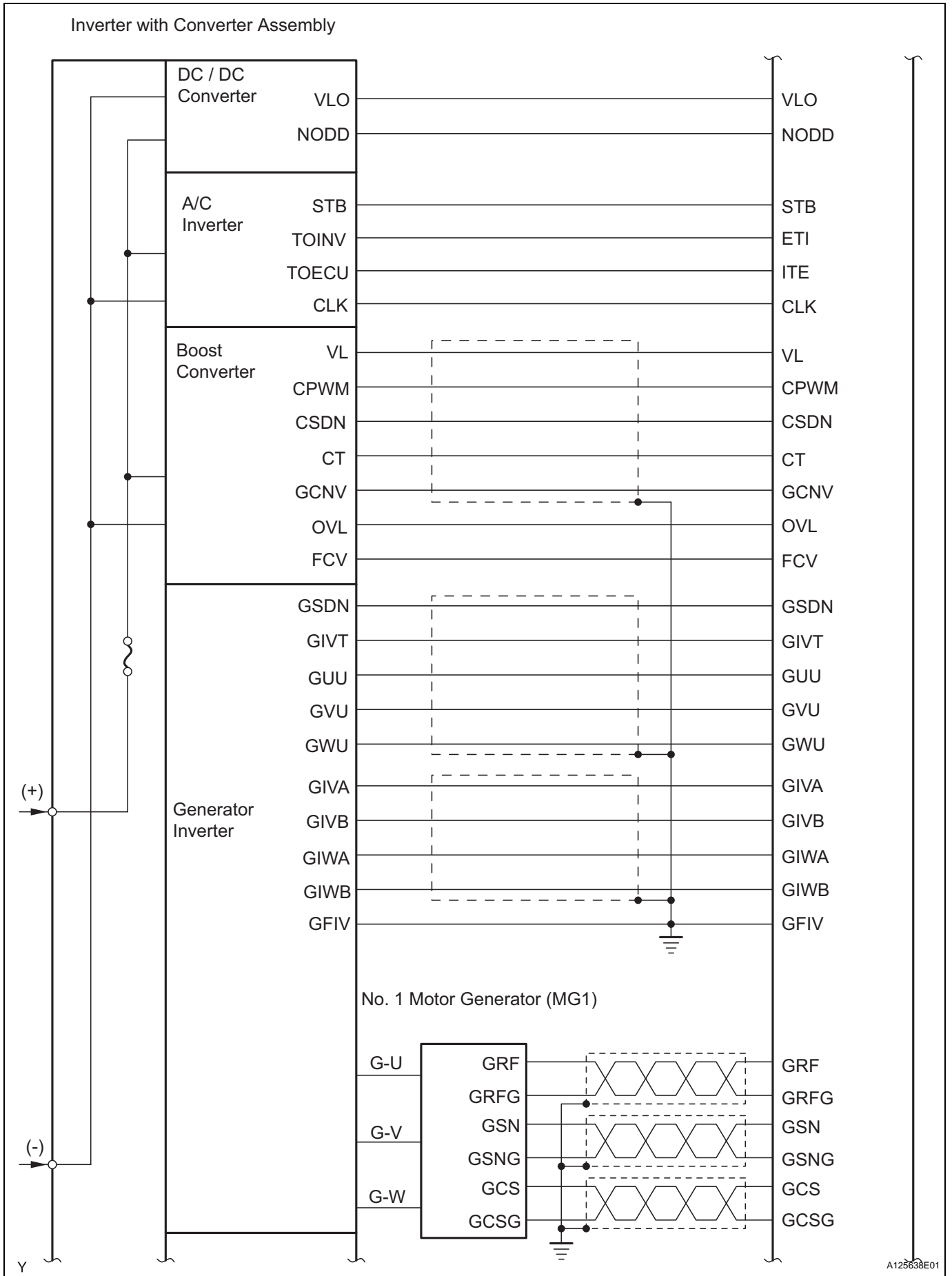

HV

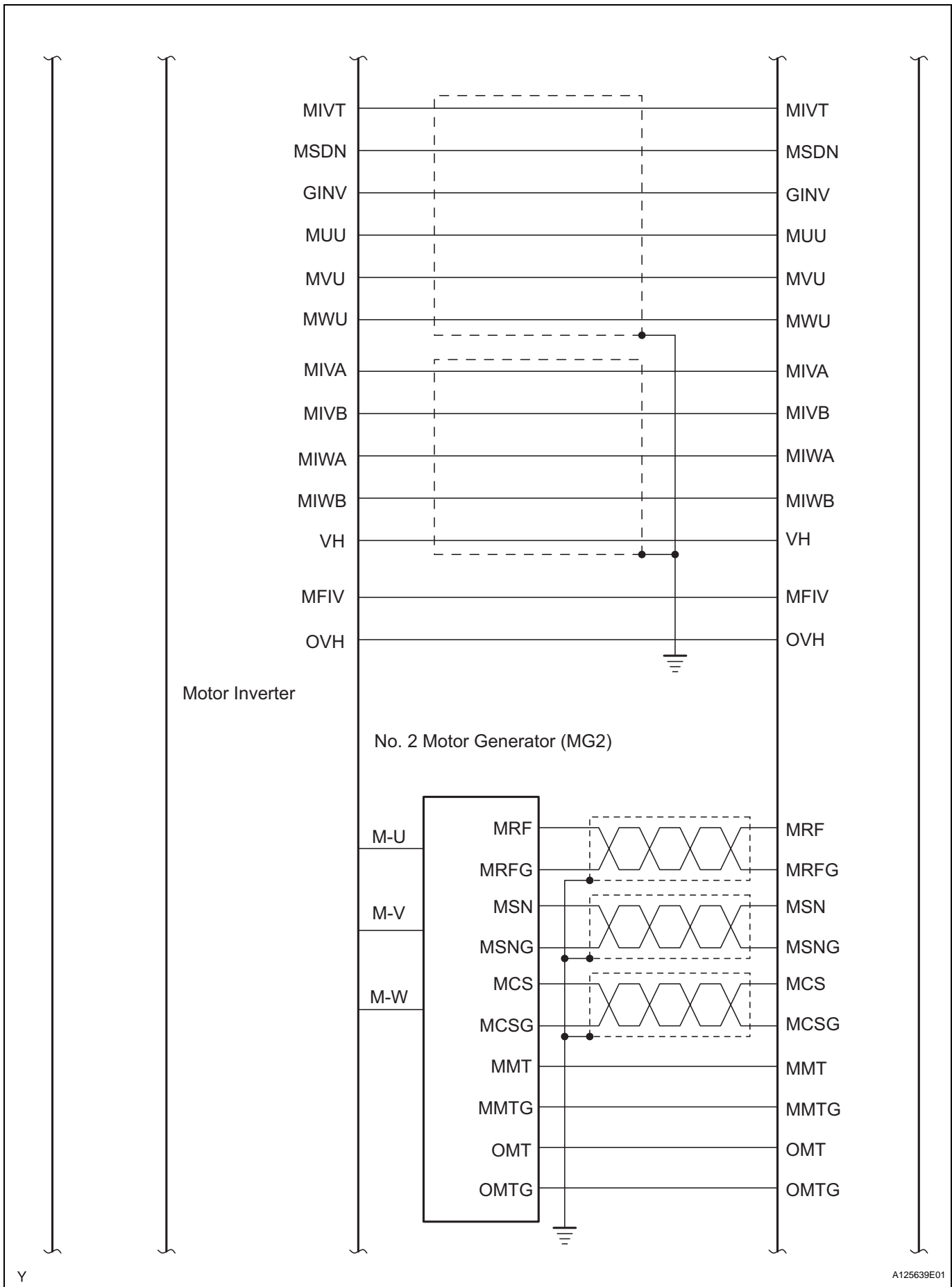

HV

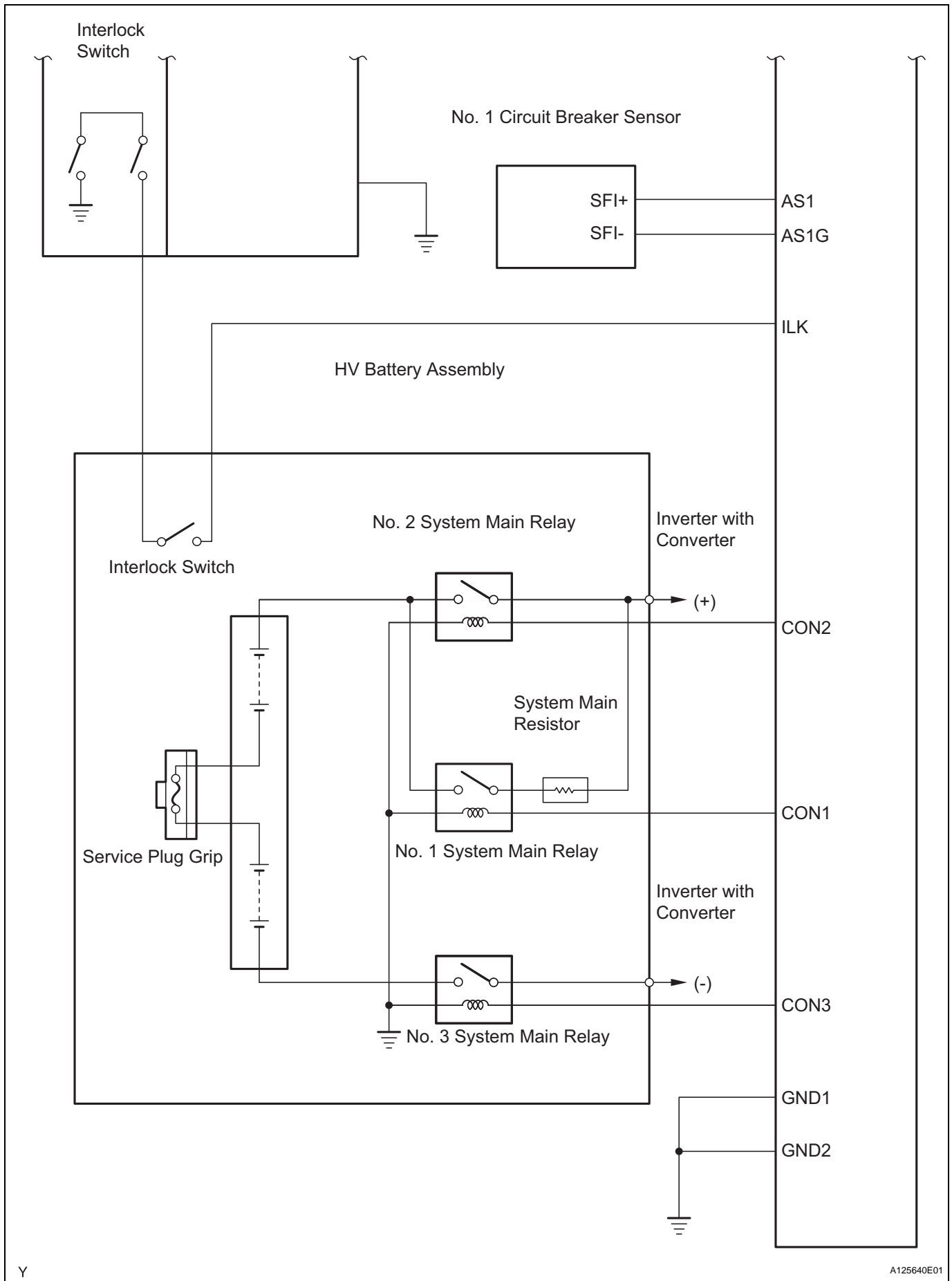

HV

Communication Diagram:

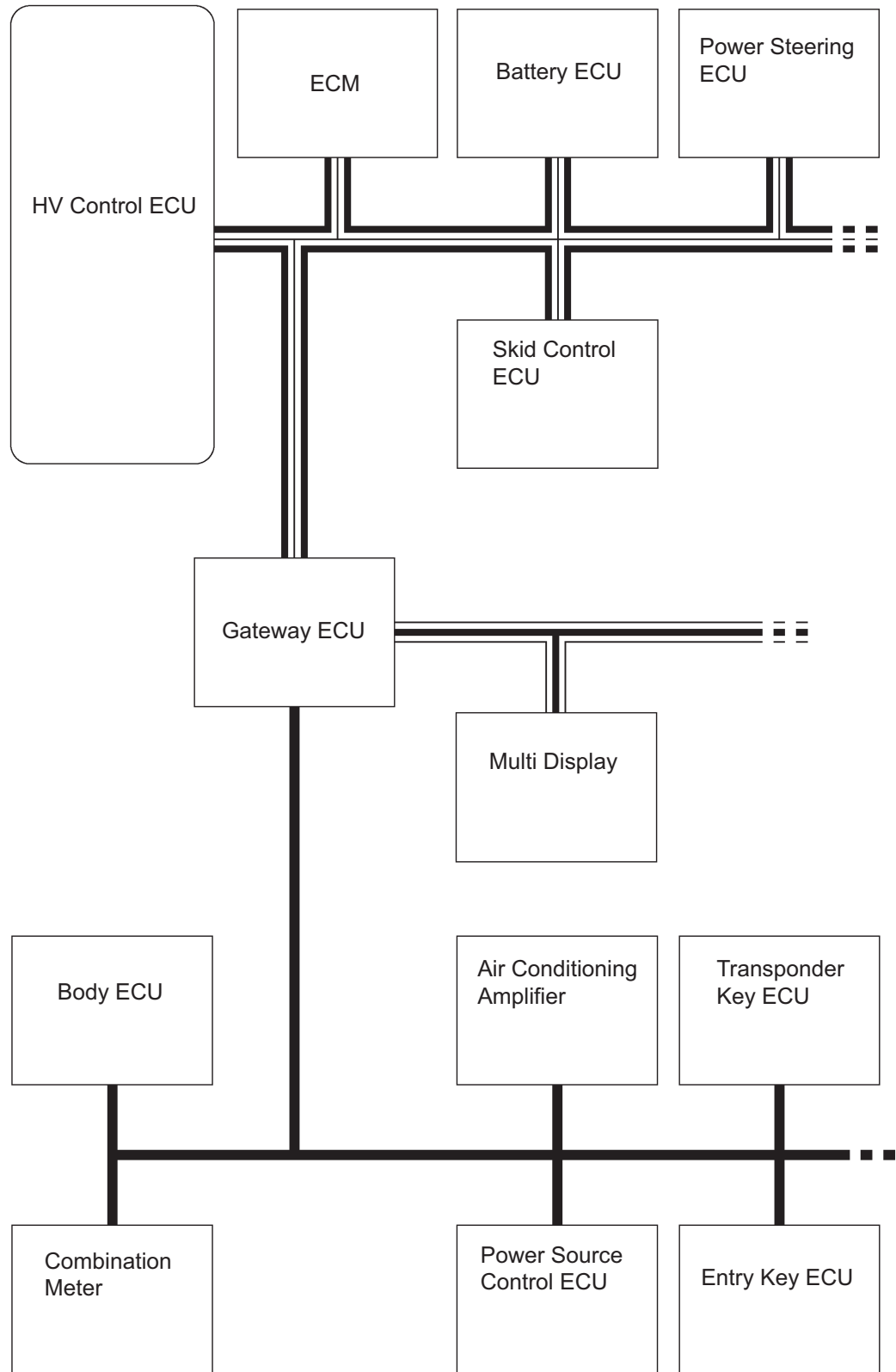

HV

SYSTEM DESCRIPTION

1. GENERAL

The THS-II control system consists of the following controls.

Item	Outline
HV Control ECU Control	<ul style="list-style-type: none"> The HV control ECU controls the MG1, MG2, engine, regenerative brake control and HV battery SOC. These factors are determined by the shift position, accelerator pedal position and vehicle speed. The HV control ECU monitors the SOC and temperature of the HV battery, MG1 and MG2, in order to optimally control these items. When the shift position is in N, the HV control ECU effects shutdown control to electrically stop the MG1 and MG2. If there is no traction at the drive wheels, the HV control ECU performs a motor traction control function which restrains the rotation of MG2, in order to protect the planetary gear unit and prevent MG1 from generating excessive electricity. To protect the circuit from high voltage and to ensure circuit shutdown reliability, the HV control ECU effects SMR control using 3 relays to connect and shut down the high-voltage circuit.
ECM Control	The ECM receives the demand power value and the target rpm, which were sent from the HV control ECU, and controls the ETCS-i system, fuel injection volume, ignition timing and VVT-i system.
Inverter Control	<ul style="list-style-type: none"> In accordance with the signals provided by the HV control ECU, the inverter converts a direct current (HV battery) into an alternating current (MG1 and MG2), or vice versa. In addition, the inverter supplies the AC (MG1) power to the AC (MG2). However, when electricity is supplied from MG1 to MG2, the electricity is converted into DC inside the inverter. The HV control ECU sends the signal to the power transistor in the inverter for switching the U, V and W phase of the MG1 and MG2 in order to drive the MG1 and MG2. The HV control ECU shuts down if it receives an overheating, over current, or fault voltage signal from the inverter.
Boost Converter Control	<ul style="list-style-type: none"> In accordance with the signals provided by the HV control ECU, the boost converter boosts the nominal voltage of DC 201.6 V (for HV battery) up to the maximum voltage of DC 500 V. The maximum voltage of AC 500 V generated by the MG1 or MG2 is converted into a direct current by the inverter, the boost converter reduces the direct current to DC 201.6 V (for HV battery) based on the signals from the HV control ECU.
Converter Control	<ul style="list-style-type: none"> The DC / DC converter reduces the nominal voltage of DC 201.6 V to DC 12 V in order to supply electricity to body electrical components, as well as to recharge the auxiliary battery (DC 12 V). This converter maintains a constant voltage at the terminals of the auxiliary battery.
A/C Inverter Control	A/C inverter converts the nominal voltage of the HV battery from DC 201.6 to AC 201.6 V and supplies power to operate the electric compressor of the A/C system.
MG1 and MG2 Main Control	<ul style="list-style-type: none"> MG1, which is rotated by the engine, generates high voltage (maximum voltage of AC 500 V) in order to operate the MG2 and charge the HV battery. Also, it functions as a starter to start the engine. MG2 primarily provides additional power to the engine in order to increase the overall drive force. During braking, or when the accelerator pedal is not depressed, it generates electricity to recharge the HV battery (regenerative brake system). Speed sensors detect the speed and position of the MG1 and MG2 and output them to the HV control ECU. A temperature sensor mounted on the MG2 detects a MG2 temperature and transmits it to the HV control ECU.

Item	Outline
Skid Control ECU Control	During braking, the skid control ECU calculates the total braking force and transmits a regenerative brake force request to the HV control ECU. Upon receiving this signal, the HV control ECU calculates the magnitude of regeneration brake force required and transmits it to the skid control ECU. Based on this, the skid control ECU calculates and executes the required hydraulic pressure brake force.
Battery ECU Control	The battery ECU monitors the condition of the HV battery and controls the cooling fan to keep the HV battery at a predetermined temperature. Thus, it optimally controls these components.
Shift Control	<ul style="list-style-type: none"> The HV control ECU detects the shift position (P, R, N, D, or B) in accordance with the signal provided by the shift position sensor, and controls the MG1, MG2, and engine, in order to create the driving conditions that suit the selected shift position. The transmission control ECU assembly detects that the driver has pressed the P position switch through a signal provided by the HV control ECU. The transmission control ECU assembly then operates the shift control actuator in order to mechanically lock the transaxle.
During Collision Control	At the time of a collision, if the HV control ECU receives an airbag deployment signal from the center airbag sensor or an actuation signal from the circuit breaker sensor located in the inverter, it turns OFF the SMR and power switch in order to shut off the entire power supply.
Cruise Control System Operation Control	When the cruise control ECU built into the HV control ECU receives a cruise control switch signal, it calculates the cruise control request value, and calculates the motive forces of the engine, MG1, and MG2 to achieve an optimal combination.
Indicator and Warning Light Illumination Control	Illuminates or blinks the lights to inform the driver of the vehicle condition or a system malfunction.
Diagnosis	When the HV control ECU detects a malfunction, the HV control ECU diagnoses and stores values corresponding to the failure.
Fail-safe	When the HV control ECU detects a malfunction, the HV control ECU stops or controls the actuator and ECUs according to the data already stored in its memory.

HV

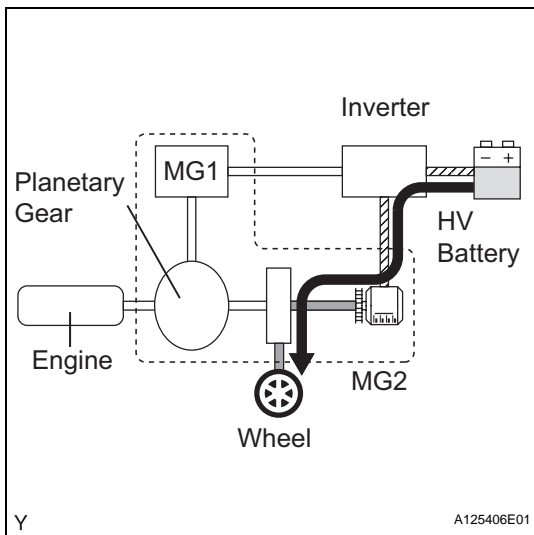

2. BASIC OPERATION

- (a) This system controls the following modes in order to achieve the most efficient operations to match the driving conditions:
 - (1) Supply of electrical power from the HV battery to MG2 provides force to drive the wheels.

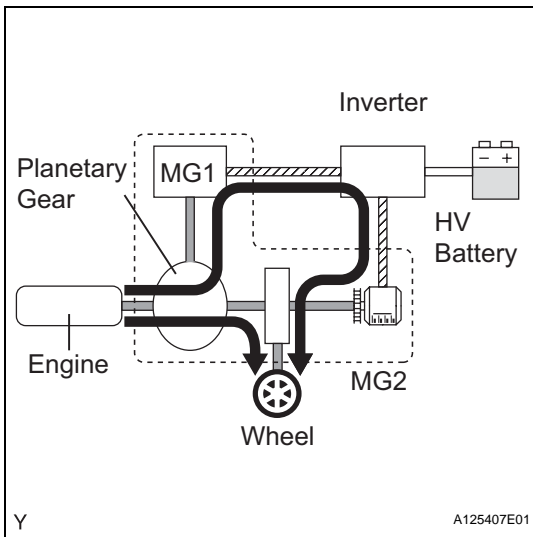

(2) While the wheels are being driven by the engine via the planetary gear, MG1 is rotated by the engine via the planetary gears, in order to supply the generated electricity to MG2.

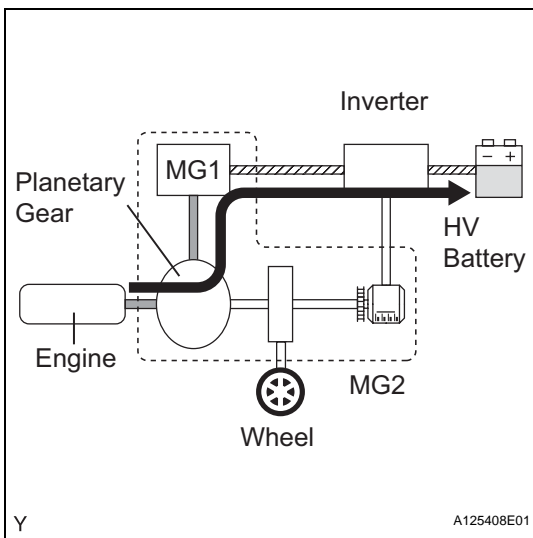

(3) MG1 is rotated by the engine via the planetary gear, in order to charge the HV battery.

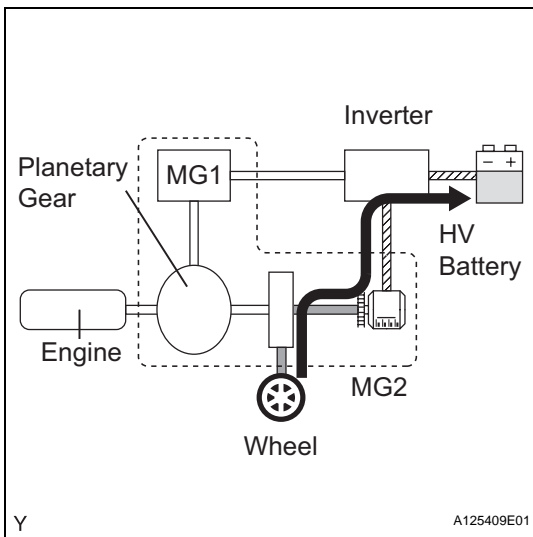

(4) When the vehicle is decelerating, kinetic energy from the wheels is recovered and converted into electrical energy and used to recharge the HV battery by means of MG2.

(b) The HV control ECU switches between these modes ((1), (2), (3), (1) + (2) + (3), or (4)) according to the driving condition. However, when the SOC (State of Charge) of the HV battery is low, the HV battery is charged by the engine by turning MG1. As a result, it achieves far greater fuel economy compared to conventional gasoline engine vehicles, at a reduced level of exhaust gas emissions. Furthermore, this revolutionary powertrain has eliminated the constraints that are associated with electric vehicles (such as their short cruising range or their reliance on external recharging units).

3. SYSTEM DIAGRAM

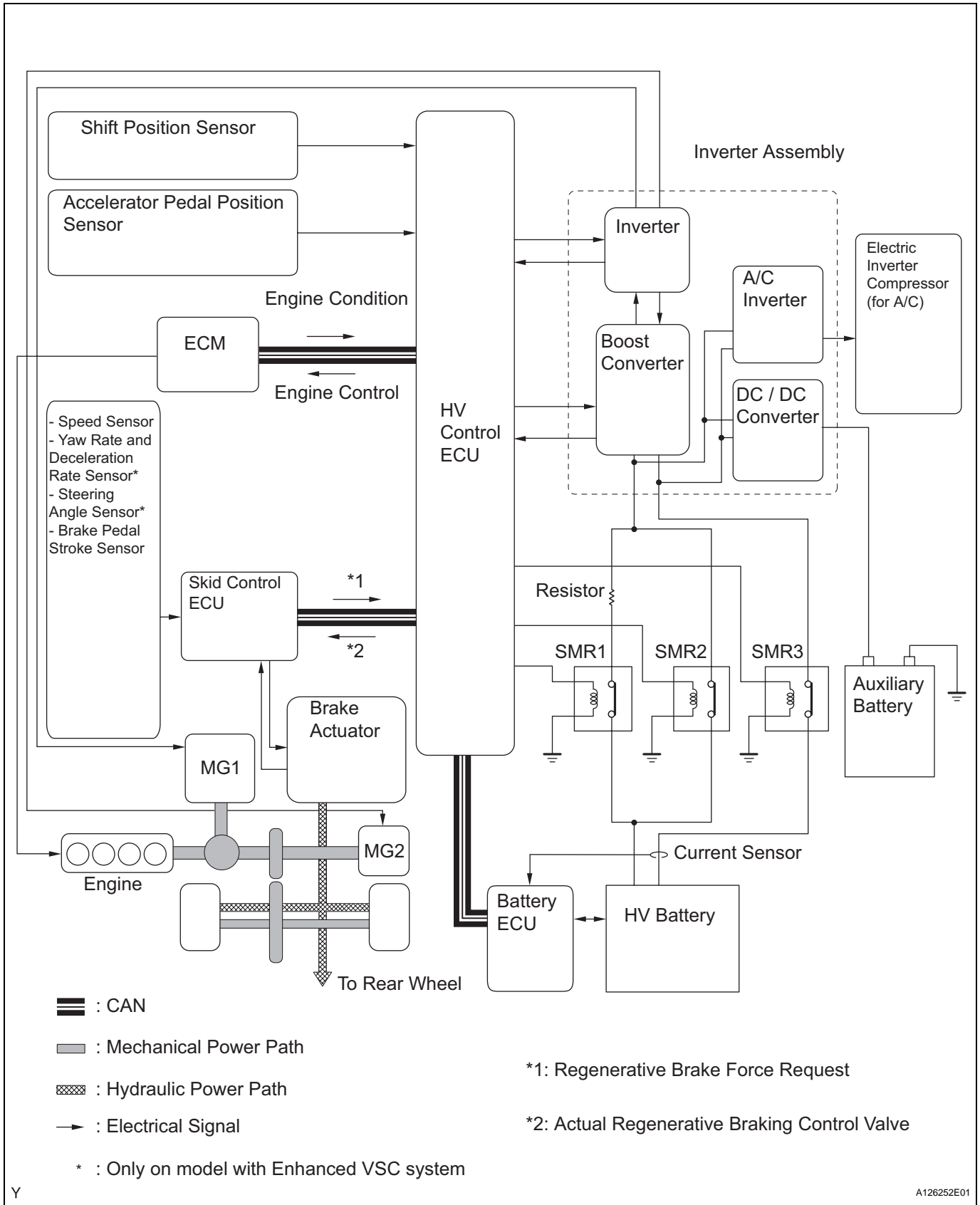

HV

Y

A126252E01

4. FUNCTION OF MAIN COMPONENTS

Item	Outline
MG1	MG1, which is rotated by the engine, generates high-voltage electricity in order to operate the MG2 or charge the HV battery. Also, it functions as a starter to start the engine.
MG2	<ul style="list-style-type: none"> Driven by electrical power from the MG1 or HV battery, and generates motive force for the vehicle. During braking, or when the accelerator pedal is not depressed, it generates electricity to recharge the HV battery (regenerative brake control).
Planetary Gear Unit	Distributes the engine's drive force as appropriate to directly drive the vehicle as well as the generator.
HV Battery	Supplies electric power to the MG2 during start-off, acceleration, and uphill driving. Recharged during braking or when the accelerator pedal is not depressed.
Inverter	Converts the high-voltage DC (HV battery) into AC (MG1 and MG2) and vice versa (converts AC into DC).
Boost Converter	Boosts the nominal voltage of the HV battery from DC 201.6 to DC 500 V and vice versa (reduces voltage from DC 500 V to DC 201.6 V).
DC / DC Converter	Reduces the nominal voltage of DC 201.6 V to DC 12 V in order to supply electricity to body electrical components, as well as to recharge the auxiliary battery (DC 12 V).
A/C Inverter	Converts the nominal voltage of DC 201.6 V of the HV battery to AC 201.6 V and supplies power to operate the electric inverter compressor of the A/C system.
HV Control ECU	Receives information from each sensor as well as from the ECUs (ECM, battery ECU, skid control ECU, and EPS ECU), and based on this information, required torque and output power are calculated. Sends the calculated result to the ECM, inverter assembly, battery ECU and skid control ECU.
ECM	Activates the ETCS-i (Electronic Throttle Control System-intelligent) in accordance with the target engine speed and required engine motive force received from the HV control ECU.
Battery ECU	Monitors the charging condition of the HV battery.
Skid Control ECU	Controls the regenerative brake that is effected by the MG2 and the hydraulic brake so that the total braking force equals that of a conventional vehicle that is equipped only with hydraulic brakes. Also, performs the brake system control (ABS with EBD, Brake Assist, and Enhanced VSC*) conventionally.
Accelerator Pedal Position Sensor	Converts the accelerator pedal position angle into an electrical signal and outputs it to the HV control ECU.
Shift Position Sensor	Converts the shift position into an electrical signal and outputs it to the HV control ECU.
SMR (System Main Relay)	Connects and disconnects the high-voltage power circuit between the battery and the inverter assembly, using a signal from the HV control ECU.
Interlock Switch (for Inverter Cover and Service Plug Grip)	Verifies that the cover of both the inverter and the service plug grip have been installed.
Circuit Breaker Sensor	The high-voltage circuit is interrupted if a vehicle collision has been detected.
Service Plug Grip	Shuts off the high-voltage circuit of the HV battery when this plug is removed for vehicle inspection or maintenance.

HINT:

*: Only on model with Enhanced VSC System

HV

HOW TO PROCEED WITH TROUBLESHOOTING

HINT:

*: Use the intelligent tester.

1 VEHICLE BROUGHT TO WORKSHOP

NEXT

2 CUSTOMER PROBLEM ANALYSIS

NEXT

3 CONNECT INTELLIGENT TESTER TO DLC3*

HINT:

If the display indicates a communication fault in the tester, inspect the DLC3.

NEXT

4 CHECK AND RECORD DTC AND FREEZE FRAME DATA*

HINT:

If a DTC related to the CAN communication system malfunction is output, first troubleshoot and repair the CAN communication (see page [CA-6](#)).

NEXT

5 CLEAR DTC*

NEXT

6 PROBLEM SYMPTOM CONFIRMATION

(a) When the malfunction does not occur, go to A.

(b) When the malfunction occurs, go to B.

B

Go to step 8

A

7 SYMPTOM SIMULATION

NEXT

8	CHECK DTC*
----------	-------------------

NEXT

9	DTC CHART
----------	------------------

NEXT

10	CIRCUIT INSPECTION
-----------	---------------------------

NEXT

11	IDENTIFICATION OF PROBLEM
-----------	----------------------------------

NEXT

12	ADJUSTMENT AND / OR REPAIR
-----------	-----------------------------------

NEXT

13	CONFIRMATION TEST
-----------	--------------------------

NEXT

END

CHECK FOR INTERMITTENT PROBLEMS

1. CHECK FOR INTERMITTENT PROBLEMS

- (a) Perform a simulation test (see page [IN-36](#)).
 - (1) In the simulation test, reproduce the driving condition at the trouble occurrence according to the customer's comments and freeze frame data recorded with DTCs, such as an opening angle of the accelerator pedal, SOC, engine coolant temperature, engine rpm, and MG1/MG2 rpm and torque.
- (b) Check the connector(s) and terminal(s) (see page [IN-45](#)).
- (c) Wiggle the harness and connector(s) (see page [IN-45](#)).

REGISTRATION

NOTICE:

The Vehicle Identification Number (VIN) must be input into the replacement HV control ECU.

HINT:

The VIN is a 17-digit alphanumeric vehicle identification number. The intelligent tester is required to register the VIN.

1. INPUT INSTRUCTIONS

- (a) Explains the general VIN input instructions using the intelligent tester.
- (b) Intelligent Tester
The arrow buttons (UP, DOWN, RIGHT and LEFT) and numerical buttons (0 to 9) are used to input the VIN.
- (c) Cursor Operation
To move the cursor around the tester screen, press the RIGHT and LEFT buttons.
- (d) Alphabetical Character Input
 - (1) Press the UP and DOWN buttons to select the desired alphabetical character.
 - (2) After selection, the cursor should move.
- (e) Numeric Character Input
 - (1) Press the numerical button corresponding to the number that you want to input.
 - (2) Select or input the correct character using the UP/DOWN buttons, or the numerical buttons.
HINT:
Numerical characters can be selected by using the UP and DOWN buttons.
- (f) Correction
 - (1) After input, the cursor should move.
 - (2) When correcting the input character(s), put the cursor onto the character using the RIGHT or LEFT buttons.
- (g) Finishing Input Operation
 - (1) Make sure that the input VIN matches the vehicle VIN after input.
 - (2) Press the ENTER button on the tester.

2. READ VIN (Vehicle Identification Number)

- (a) Explains the VIN reading process in a flowchart. Reading the VIN stored in the HV control ECU is necessary when comparing it to the VIN provided with the vehicle.
- (b) Read VIN using the intelligent tester.
- (c) Check the vehicle's VIN.
- (d) Connect the intelligent tester to the DLC3.
- (e) Turn the power switch ON (IG).
- (f) Turn the tester ON.

(g) Enter the following menus: DIAGNOSIS / ENHANCED OBD II / VIN.

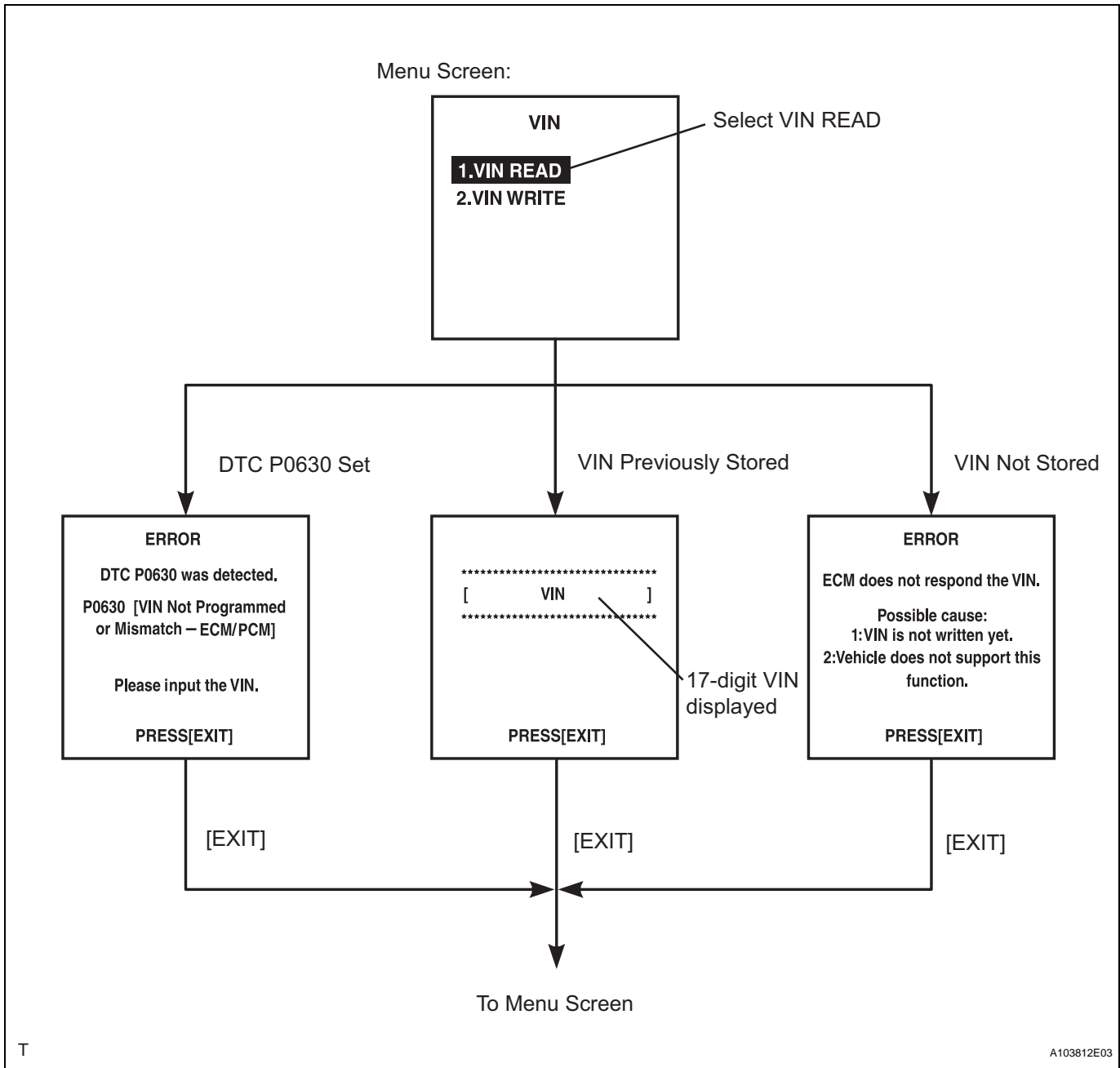

3. WRITE VIN

- (a) Explains the VIN writing process in a flowchart. This process allows the VIN to be input into the HV control ECU. If the HV control ECU is changed, or the HV control ECU VIN and Vehicle VIN do not match, the VIN can be registered, or overwritten in the HV control ECU by following this procedure.
- (b) Write VIN using the intelligent tester.
- (c) Connect the intelligent tester to the DLC3.
- (d) Turn the power switch ON (IG).
- (e) Turn the tester ON.

(f) Enter the following menus: DIAGNOSIS / ENHANCED OBD II / VIN.

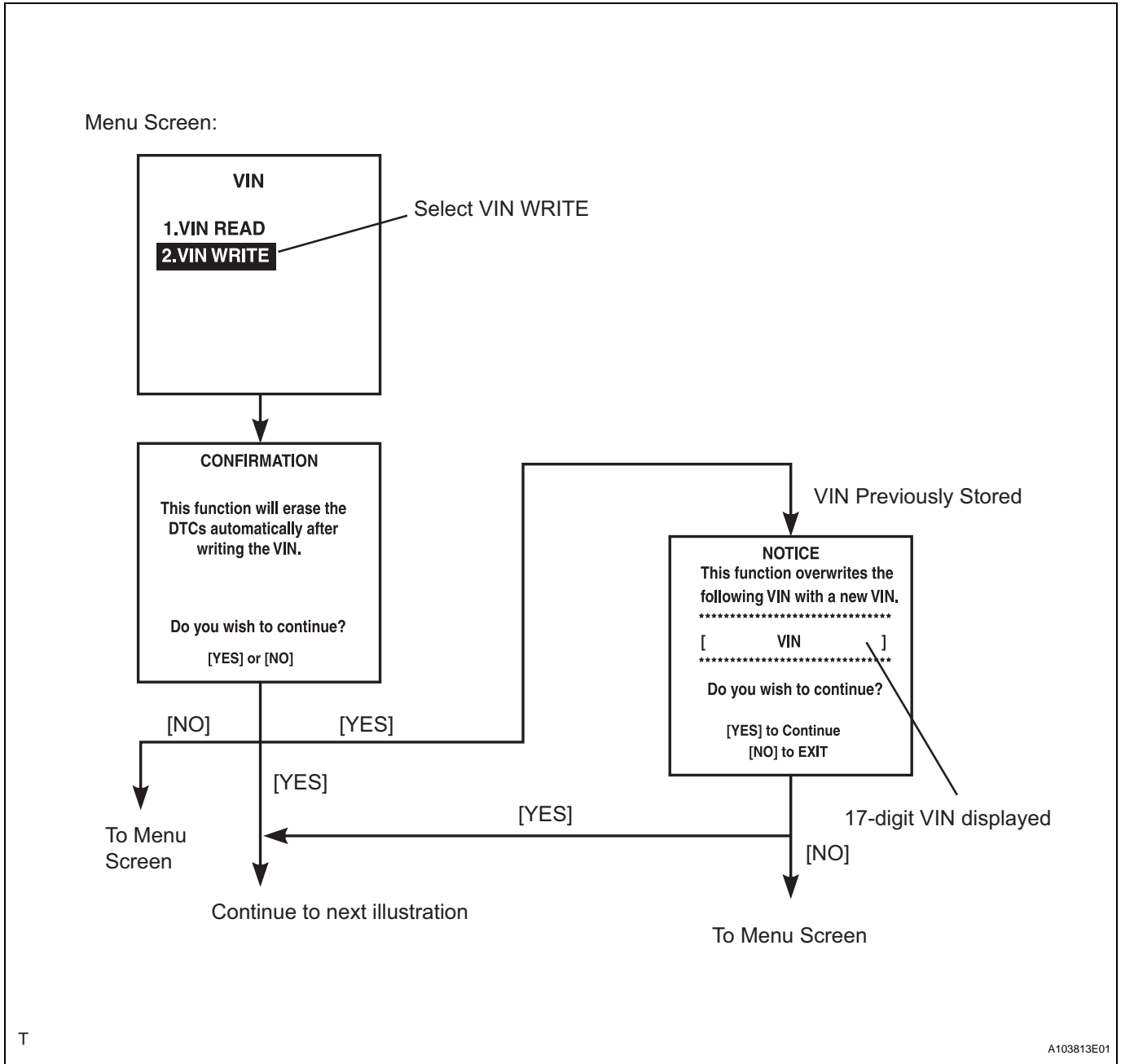

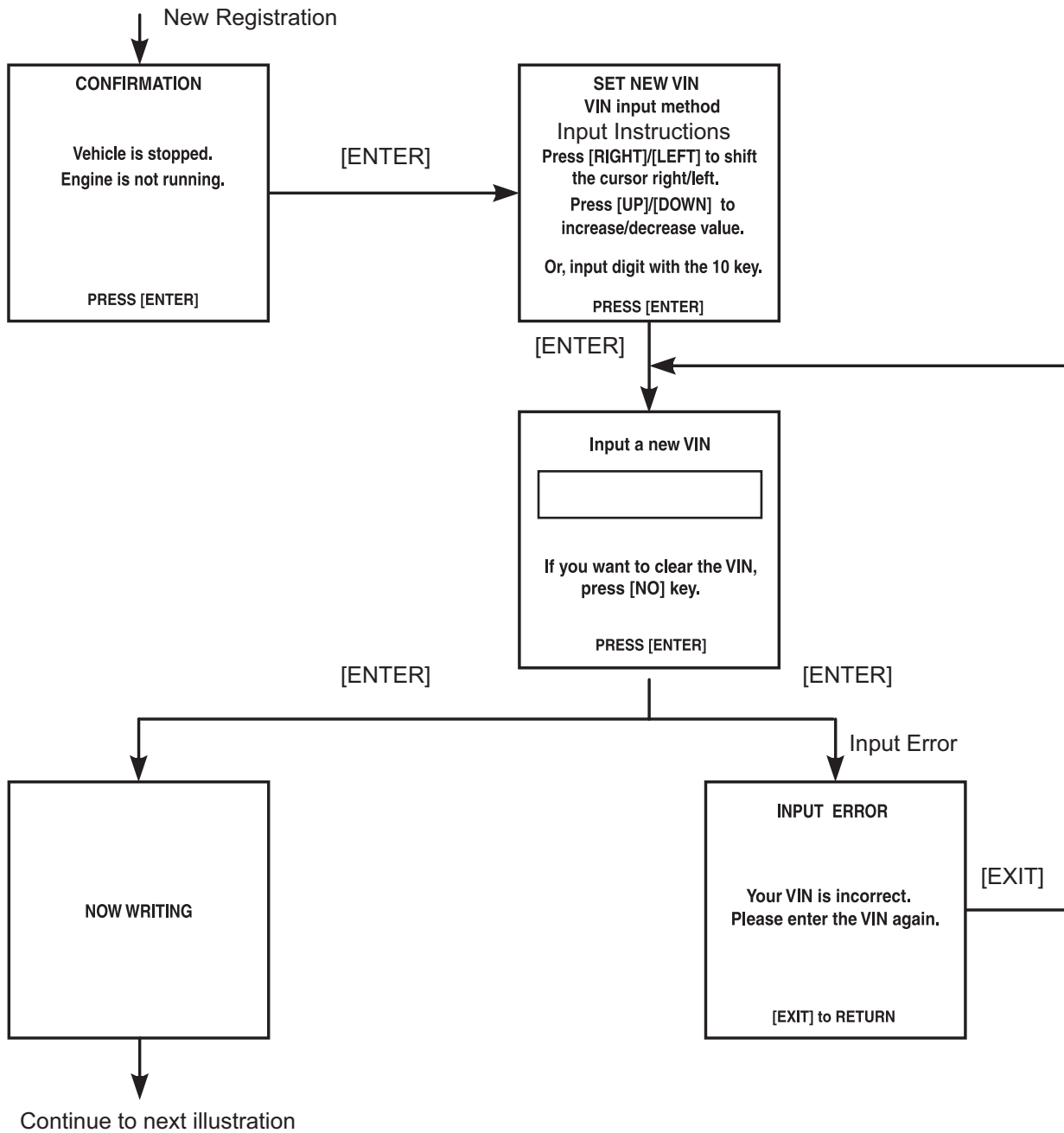

HV

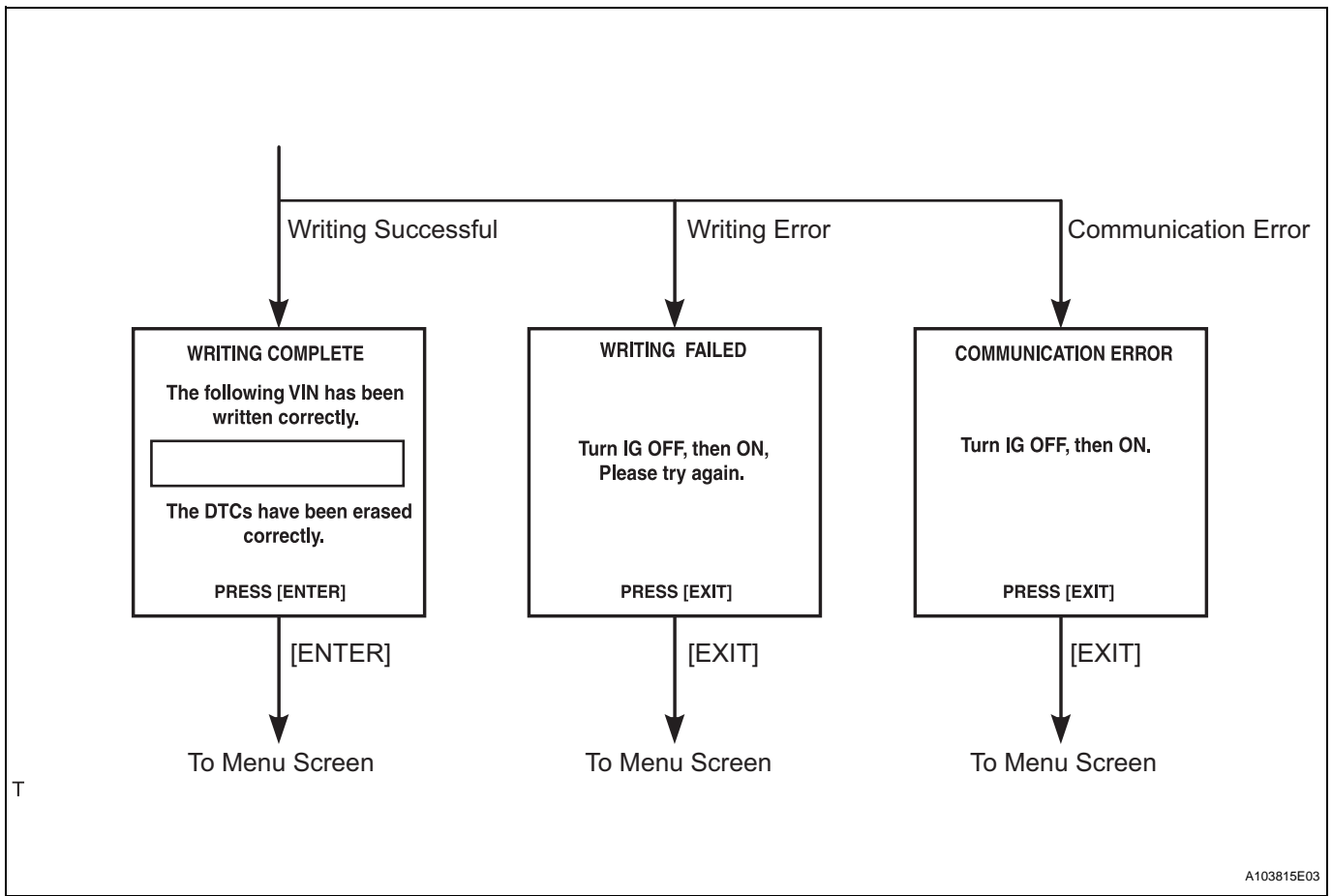

T

A103815E03

TERMINALS OF ECU

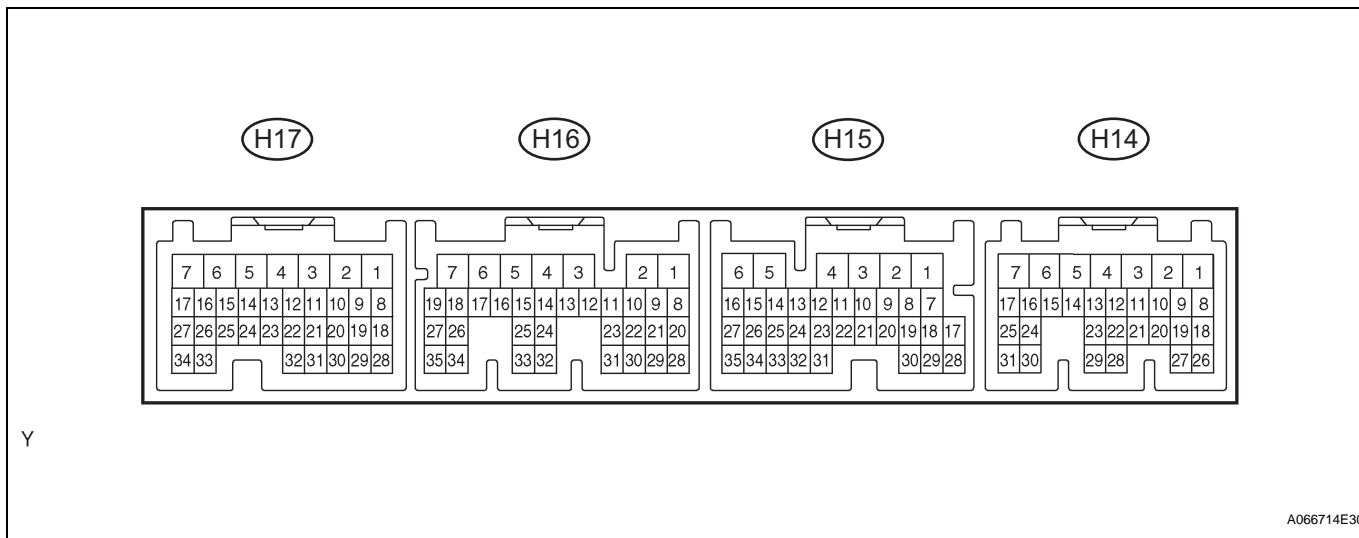

Y

A066714E30

Symbols (Terminal No.)	Wiring Color	Terminal Description	Condition	STD Voltage (V)
ST2 (H14-5) - GND1 (H14-1)	Y - W-B	Starter signal	Power switch ON (READY)	9 to 14
IGSW (H14-7) - GND1 (H14-1)	O - W-B	IG signal	Power switch ON (IG)	9 to 14
BATT (H15-6) - GND1 (H14-1)	Y - W-B	Auxiliary battery (for measuring the battery voltage and for the HV control ECU memory)	Always	9 to 14
+B1 (H16-7) - GND1 (H14-1)	L - W-B	Power source of HV control ECU	Power switch ON (IG)	9 to 14
+B2 (H16-6) - GND1 (H14-1)	L - W-B	Power source of HV control ECU	Power switch ON (IG)	9 to 14
MREL (H16-4) - GND1 (H14-1)	O - W-B	Main relay	Power switch ON (IG)	9 to 14
CANH (H14-8) - GND1 (H14-1)	B - W-B	HIGH-level CAN bus line	Power switch ON (IG)	Pulse generation (see waveform 1)
CANL (H14-9) - GND1 (H14-1)	W - W-B	LOW-level CAN bus line	Power switch ON (IG)	Pulse generation (see waveform 2)
NEO (H16-12) - GND1 (H14-1)	LG - W-B	Engine speed signal	Engine running	Pulse generation (see waveform 3)
GO (H16-13) - GND1 (H14-1)	Y - W-B	G signal	Engine running	Pulse generation (see waveform 4)
SPDI (H14-19) - GND1 (H14-1)	V - W-B	Vehicle speed signal	Driving at approximately 12 mph (20 km/h)	Pulse generation (see waveform 5)
VPA1 (H16-26) - EP1 (H16-27)	L - B	Accelerator pedal position sensor (for the HV system)	Power switch ON (IG), accelerator pedal released	0.5 to 1.1
VPA1 (H16-26) - EP1 (H16-27)	L - B	Accelerator pedal position sensor (for the HV system)	Power switch ON (IG), engine stopped in P position, accelerator pedal fully depressed	2.6 to 4.5
VPA2 (H16-34) - EP2 (H16-35)	W - R	Accelerator pedal position sensor (for the sensor malfunction detection)	Power switch ON (IG), accelerator pedal fully depressed	1.2 to 2.0
VPA2 (H16-34) - EP2 (H16-35)	W - R	Accelerator pedal position sensor (for the sensor malfunction detection)	Power switch ON (IG), engine stopped in P position, accelerator pedal released	3.4 to 5.3
VCP1 (H16-25) - EP1 (H16-27)	Y - B	Power source of accelerator pedal position sensor (for VPA1)	Power switch ON (IG)	4.5 to 5.5

HV

Symbols (Terminal No.)	Wiring Color	Terminal Description	Condition	STD Voltage (V)
VCP2 (H16-33) - EP2 (H16-35)	G - R	Power source of accelerator pedal position sensor (for VPA2)	Power switch ON (IG)	4.5 to 5.5
VSX1 (H14-25) - E2X1 (H14-15)	B - R	Shift position sensor (main)	Power switch ON (IG), selector lever home position	2.0 to 3.0
VSX1 (H14-25) - E2X1 (H14-15)	B - R	Shift position sensor (main)	Power switch ON (IG), selector lever moved to R position	4.0 to 4.8
VSX1 (H14-25) - E2X1 (H14-15)	B - R	Shift position sensor (main)	Power switch ON (IG), selector lever moved to B or D position	0.2 to 1.0
VSX2 (H14-24) - E2X2 (H14-14)	L - Y	Shift position sensor (sub)	Power switch ON (IG), selector lever home position	2.0 to 3.0
VSX2 (H14-24) - E2X2 (H14-14)	L - Y	Shift position sensor (sub)	Power switch ON (IG), selector lever moved to R position	4.0 to 4.8
VSX2 (H14-24) - E2X2 (H14-14)	L - Y	Shift position sensor (sub)	Power switch ON (IG), selector lever moved to B or D position	0.2 to 1.0
VCX1 (H14-17) - E2X1 (H14-15)	W - R	Power source of shift position sensor (for VSX1)	Power switch ON (IG)	4.5 to 5.5
VCX2 (H14-16) - E2X2 (H14-14)	G - Y	Power source of shift position sensor (for VSX2)	Power switch ON (IG)	4.5 to 5.5
VSX3 (H14-23) - GND1 (H14-1)	BR - W-B	Select position sensor (main)	Power switch ON (IG), selector lever home position	0.5 to 2.0
VSX3 (H14-23) - GND1 (H14-1)	BR - W-B	Select position sensor (main)	Power switch ON (IG), selector lever moved to R, N or D position	3.0 to 4.85
VSX4 (H14-30) - GND1 (H14-1)	SB - W-B	Select position sensor (sub)	Power switch ON (IG), selector lever home position	0.5 to 2.0
VSX4 (H14-30) - GND1 (H14-1)	SB - W-B	Select position sensor (sub)	Power switch ON (IG), selector lever moved to R, N or D position	3.0 to 4.85
VCX3 (H14-21) - GND1 (H14-1)	W - W-B	Power source of select position sensor (for VSX3)	Power switch ON (IG)	9 to 14
VCX4 (H14-31) - GND1 (H14-1)	P - W-B	Power source of select position sensor (for VSX4)	Power switch ON (IG)	9 to 14
NODD (H16-24) - GND1 (H14-1)	V - W-B	DC / DC movement monitor or stop request signal	When converter is in normal operation	5 to 7
NODD (H16-24) - GND1 (H14-1)	V - W-B	DC / DC movement monitor or stop request signal	When converter is improper	2 to 4
NODD (H16-24) - GND1 (H14-1)	V - W-B	DC / DC movement monitor or stop request signal	When converter is required to stop	0.1 to 0.5
VLO (H16-31) - GND1 (H14-1)	L - W-B	Two-stage selector signal	Converter switching to 14 V output	13 to 14
VLO (H16-31) - GND1 (H14-1)	L - W-B	Two-stage selector signal	Converter switching to 13.5 V output	Below 0.5
TC (H14-6) - GND1 (H14-1)	P - W-B	Terminal TC of DLC3	Power switch ON (IG)	9 to 14
STP (H15-3) - GND1 (H14-1)	L - W-B	Stop light switch	Brake pedal depressed	9 to 14
STP (H15-3) - GND1 (H14-1)	L - W-B	Stop light switch	Brake pedal released	2 to 3

Symbols (Terminal No.)	Wiring Color	Terminal Description	Condition	STD Voltage (V)
ABFS (H14-20) - GND1 (H14-1)	L - W-B	Airbag deployment signal	Power switch ON (READY) (2 seconds after ON [ACC])	Pulse generation (see waveform 6, 7, 8)
AS1 (H16-15) - AS1G (H16-16)	Y - W	No. 1 circuit breaker sensor	Satellite signal system normal	2.5 to 2.9
ILK (H15-1) - GND1 (H14-1)	V - W-B	Interlock switch	Power switch ON (IG), inverter cover and service plug grip installed normally	Below 1
ILK (H15-1) - GND1 (H14-1)	V - W-B	Interlock switch	Power switch ON (IG), inverter cover or service plug grip detached	9 to 14
CON1 (H16-1) - GND1 (H14-1)	R - W-B	No. 1 system main relay	Power switch OFF to ON (READY)	Pulse generation (see waveform 9)
CON2 (H16-2) - GND1 (H14-1)	G - W-B	No. 2 system main relay	Power switch OFF to ON (READY)	Pulse generation (see waveform 9)
CON3 (H16-3) - GND1 (H14-1)	Y - W-B	No. 3 system main relay	Power switch OFF to ON (READY)	Pulse generation (see waveform 9)
VH (H15-26) - GINV (H15-23)	Y - W-B	Inverter condenser voltage monitor	Power switch ON (READY)	1.6 to 3.8
GUU (H15-15) - GINV (H15-23)	B - Y	Generator switch U signal	Power switch ON (IG)	Pulse generation (see waveform 10)
GVU (H15-14) - GINV (H15-23)	G - Y	Generator switch V signal	Power switch ON (IG)	Pulse generation (see waveform 10)
GWU (H15-13) - GINV (H15-23)	Y - Y	Generator switch W signal	Power switch ON (IG)	Pulse generation (see waveform 10)
GIVA (H15-34) - GINV (H15-23)	W - Y	Generator V phase current	Power switch ON (IG)	Approximately 0
GIVB (H15-33) - GINV (H15-23)	B - Y	Generator V phase current	Power switch ON (IG)	Approximately 0
GIWA (H15-32) - GINV (H15-23)	R - Y	Generator W phase current	Power switch ON (IG)	Approximately 0
GIWB (H15-31) - GINV (H15-23)	G - Y	Generator W phase current	Power switch ON (IG)	Approximately 0
GIVT (H15-27) - GINV (H15-23)	W - Y	Generator inverter temperature sensor	Power switch ON (IG)	2 to 4.5
GSDN (H15-16) - GINV (H15-23)	R - W-B	Generator shutdown signal	Power switch ON (READY), N position	0.2 to 0.7
GSDN (H15-16) - GINV (H15-23)	R - W-B	Generator shutdown signal	Power switch ON (READY), P position	5.1 to 13.6
GFIV (H15-35) - GINV (H15-23)	GR - W-B	Generator inverter fail signal	Power switch ON (IG), inverter normal	5.4 to 7.4
GFIV (H15-35) - GINV (H15-23)	GR - W-B	Generator inverter fail signal	Power switch ON (IG), inverter abnormal	2 to 3
GRF (H17-27) - GRFG (H17-26)	B - W	Generator resolver signal	Generator resolver stopped or rotating	Pulse generation (see waveform 11, 12)
GSN (H17-22) - GSNG (H17-21)	R - G	Generator resolver signal	Generator resolver stopped or rotating	Pulse generation (see waveform 11, 12)
GCS (H17-23) - GCSG (H17-24)	Y - BR	Generator resolver signal	Generator resolver stopped or rotating	Pulse generation (see waveform 11, 12)
OMT (H17-30) - OMTG (H17-29)	B - G	No. 2 motor temperature sensor	Refer to DATA LIST (see page HV-49)	-
MUU (H15-9) - GINV (H15-23)	B - Y	Motor switch U signal	Power switch ON (IG)	Pulse generation (see waveform 13)
MVU (H15-10) - GINV (H15-23)	W - Y	Motor switch V signal	Power switch ON (IG)	Pulse generation (see waveform 13)
MWU (H15-11) - GINV (H15-23)	R - Y	Motor switch W signal	Power switch ON (IG)	Pulse generation (see waveform 13)

Symbols (Terminal No.)	Wiring Color	Terminal Description	Condition	STD Voltage (V)
MIVA (H15-30) - GINV (H15-23)	G - Y	Motor V phase current	Power switch ON (IG)	Approximately 0
MIVB (H15-21) - GINV (H15-23)	W - Y	Motor V phase current	Power switch ON (IG)	Approximately 0
MIWA (H15-29) - GINV (H15-23)	R - Y	Motor W phase current	Power switch ON (IG)	Approximately 0
MIWB (H15-20) - GINV (H15-23)	B - Y	Motor W phase current	Power switch ON (IG)	Approximately 0
MIVT (H15-19) - GINV (H15-23)	L - Y	Motor inverter temperature sensor	Power switch ON (IG)	2 to 4.5
MSDN (H15-8) - GINV (H15-23)	G - W-B	Motor shutdown signal	Power switch ON (READY), N position	0.2 to 0.7
MSDN (H15-8) - GINV (H15-23)	G - W-B	Motor shutdown signal	Power switch ON (READY), P position	5.1 to 13.6
OVH (H15-22) - GINV (H15-23)	BR - W-B	Motor inverter over voltage signal	Power switch ON (IG), inverter normal	5.3 to 7.3
OVH (H15-22) - GINV (H15-23)	BR - W-B	Motor inverter over voltage signal	Power switch ON (IG), inverter abnormal	1.9 to 2.9
MFIV (H15-18) - GINV (H15-23)	G - W-B	Motor inverter fail signal	Power switch ON (IG), inverter normal	5.4 to 7.4
MFIV (H15-18) - GINV (H15-23)	G - W-B	Motor inverter fail signal	Power switch ON (IG), inverter abnormal	2 to 3
MRF (H17-34) - MRFG (H17-33)	L - P	Motor resolver signal	Motor resolver stopped or rotating	Pulse generation (see waveform 11, 12)
MSN (H17-20) - MSNG (H17-19)	G - R	Motor resolver signal	Motor resolver stopped or rotating	Pulse generation (see waveform 11, 12)
MCS (H17-32) - MCSG (H17-31)	Y - BR	Motor resolver signal	Motor resolver stopped or rotating	Pulse generation (see waveform 11, 12)
MMT (H17-18) - MMTG (H17-28)	B - R	No. 1 motor temperature sensor	Refer to DATA LIST (see page HV-49)	-
VL (H16-30) - GCNV (H16-8)	Y - G	Boost converter input voltage	Power switch ON (READY)	1.9 to 3.4
OVL (H16-22) - GCNV (H16-8)	B - G	Boost converter over voltage signal	Power switch ON (IG), boost converter normal	5.3 to 7.7
OVL (H16-22) - GCNV (H16-8)	B - G	Boost converter over voltage signal	Power switch ON (IG), boost converter abnormal	1.9 to 3.0
FCV (H16-20) - GCNV (H16-8)	W - G	Boost converter fail signal	Power switch ON (IG), boost converter normal	5.3 to 7.7
FCV (H16-20) - GCNV (H16-8)	W - G	Boost converter fail signal	Power switch ON (IG), boost converter abnormal	1.9 to 3.0
CT (H16-21) - GCNV (H16-8)	R - G	Boost converter temperature sensor	Power switch ON (IG)	2.0 to 4.5
CPWM (H16-10) - GCNV (H16-8)	B - G	Boost converter PWM switch signal	Power switch ON (READY), parking brake ON, D position, brake pedal and accelerator pedal depressed	Pulse generation (see waveform 14)
CSDN (H16-9) - GCNV (H16-8)	W - G	Boost converter shutdown signal	Power switch ON (IG)	5.6 or higher
CSDN (H16-9) - GCNV (H16-8)	W - G	Boost converter shutdown signal	Power switch ON (READY)	Below 0.7
ST1- (H15-2) - GND1 (H14-1)	G - W-B	Stop light switch (opposite to STP)	Power switch ON (IG) and brake pedal depressed	Below 0.5
ST1- (H15-2) - GND1 (H14-1)	G - W-B	Stop light switch (opposite to STP)	Power switch ON (IG) and brake pedal released	9 to 14
CCS (H14-13) - GND1 (H14-1)	V - W-B	Cruise control switch	Cruise control system - Terminal of ECU - CCS terminal (see page CC-9)	-

Symbols (Terminal No.)	Wiring Color	Terminal Description	Condition	STD Voltage (V)
IMI (H14-18) - GND1 (H14-1)	W - W-B	Immobiliser communication	Immobiliser communicating	Pulse generation (see waveform 15)
IMO (H14-26) - GND1 (H14-1)	R - W-B	Immobiliser communication	Immobiliser communicating	Pulse generation (see waveform 15)
P1 (H15-17) - GND1 (H14-1)	Y - W-B	P position switch	Power switch ON (IG), P position switch ON	3 to 5
P1 (H15-17) - GND1 (H14-1)	Y - W-B	P position switch	Power switch ON (IG), P position switch OFF	7 to 12
PCON (H17-9) - GND1 (H14-1)	LG - W-B	P position control signal	Power switch ON (IG)	Pulse generation (see waveform 16)
PPOS (H17-10) - GND1 (H14-1)	W - W-B	P position signal	Power switch ON (IG)	Pulse generation (see waveform 16)
RDY (H14-28) - GND1 (H14-1)	R - W-B	READY control signal	Power switch ON (IG)	Pulse generation (see waveform 17)
RDY (H14-28) - GND1 (H14-1)	R - W-B	READY control signal	Power switch ON (READY)	Pulse generation (see waveform 18)
CLK (H16-17) - GND1 (H14-1)	G - W-B	A/C communication	Power switch ON (IG), A/C operating	Pulse generation (see waveform 19)
ITE (H16-14) - GND1 (H14-1)	Y - W-B	A/C communication	Power switch ON (IG), A/C operating	Pulse generation (see waveform 19)
ETI (H15-24) - GND1 (H14-1)	R - W-B	A/C communication	Power switch ON (IG), A/C operating	Pulse generation (see waveform 19)
STB (H15-25) - GND1 (H14-1)	W - W-B	A/C communication	Power switch ON (IG), A/C operating	Pulse generation (see waveform 19)
WP (H16-5) - GND1 (H14-1)	O - W-B	Water pump relay control	Power switch ON (IG), A/C operating	Below 2
GND1 (H14-1) - Body ground	W-B - Body ground	Ground	Always (resistance check)	Below 5 Ω
GND2 (H14-4) - Body ground	W-B - Body ground	Ground	Always (resistance check)	Below 5 Ω

HV

1. Oscilloscope waveforms

HINT:

In the oscilloscope waveform samples, which are provided here for informational purposes. Noise and fluttering waveforms have been omitted.

2. Waveform 1

HIGH-level CAN bus line

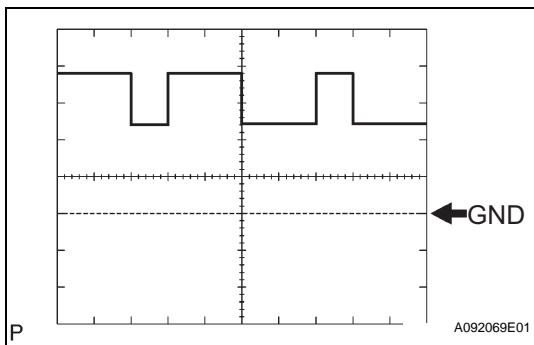

Item	Contents
Terminal	CANH - GND1
Equipment Setting	1 V/Division, 2 μs/Division
Condition	Power switch ON (IG)

HINT:

The waveform varies depending on the contents of communication.

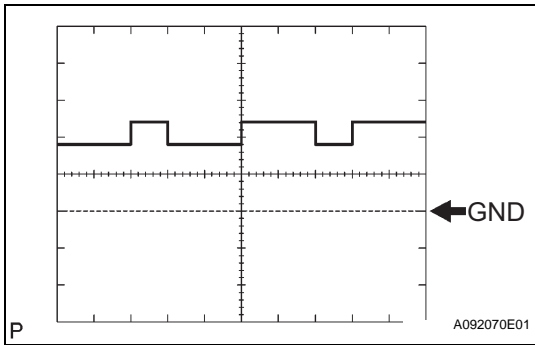

**3. Waveform 2
LOW-level CAN bus line**

Item	Contents
Terminal	CANL - GND1
Equipment Setting	1 V/Division, 2 μs/Division
Condition	Power switch ON (IG)

HINT:
The waveform varies depending on the contents of communication.

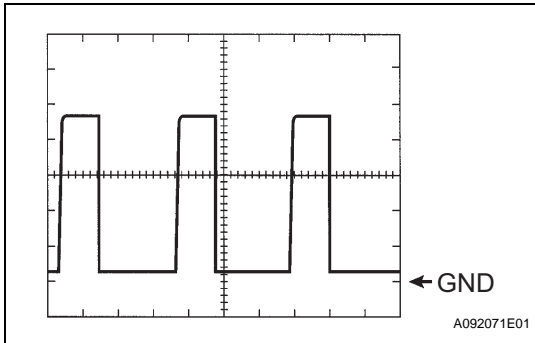

**4. Waveform 3
Engine speed signal**

Item	Contents
Terminal	NEO - GND1
Equipment Setting	1 V/Division, 2 ms/Division
Condition	Engine idling

HINT:
The pulse cycle becomes shorter as the engine speed increases.

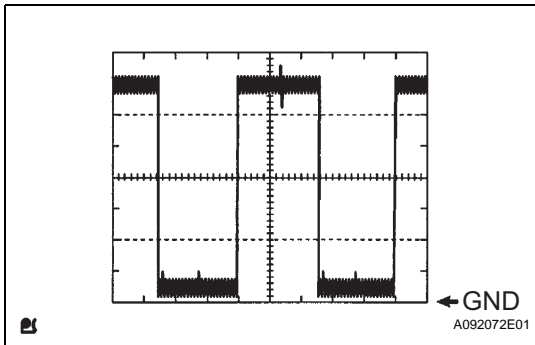

**5. Waveform 4
G signal**

Item	Contents
Terminal	GO - GND1
Equipment Setting	2 V/Division, 20 ms/Division
Condition	Engine idling

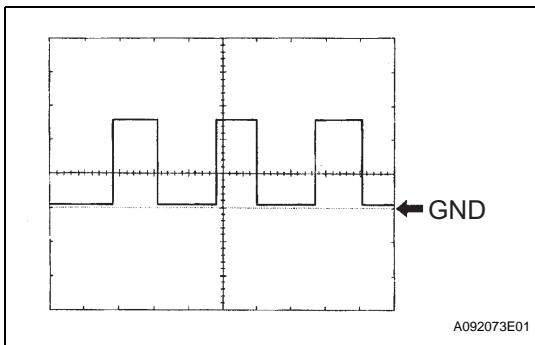

**6. Waveform 5
Vehicle speed signal**

Item	Contents
Terminal	SPDI - GND1
Equipment Setting	5 V/Division, 20 ms/Division
Condition	Driving at approximately 20 km/h (12 mph)

HINT:
The higher the vehicle speed, the shorter the cycle and higher the voltage.

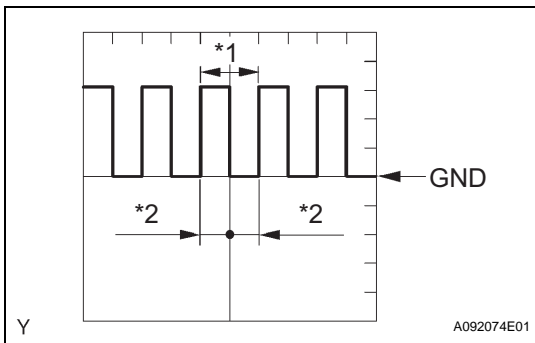

**7. Waveform 6
Airbag deployment signal**

Item	Contents
Terminal	ABFS - GND1
Equipment Setting	1 V/Division, 500 ms/Division
Condition	Power switch ON (READY) (2 seconds after ON [ACC]) Airbag system normal

*1: 1 frame
*2: 500 ms

HINT:

The waveform on the left is repeated when the airbag system is normal.

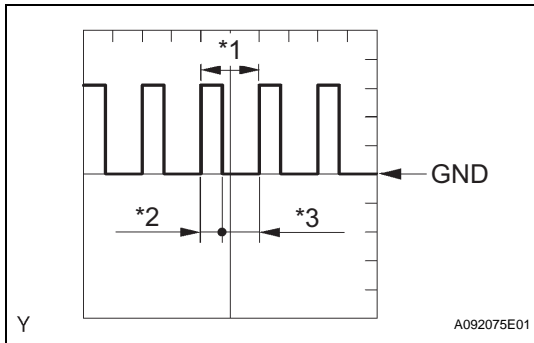

**8. Waveform 7
Airbag deployment signal**

Item	Contents
Terminal	ABFS - GND1
Equipment Setting	1 V/Division, 50 ms/Division
Condition	Power switch ON (READY) (2 seconds after ON [ACC]) Airbag system abnormal

*1: 1 frame

*2: 40 ms

*3: 60 ms

HINT:

The waveform on the left is repeated when the airbag system is abnormal.

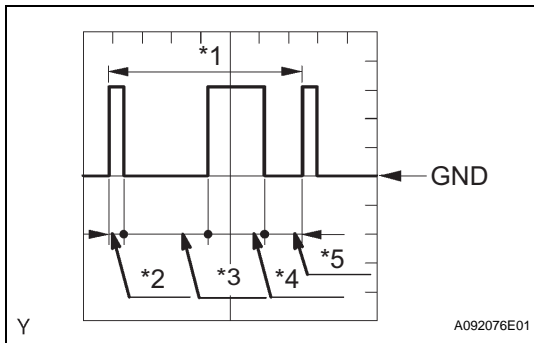

**9. Waveform 8
Airbag deployment signal**

Item	Contents
Terminal	ABFS - GND1
Equipment Setting	1 V/Division, 50 ms/Division
Condition	Power switch ON (READY) (2 seconds after ON [ACC]) Airbag system deployed (during collision)

*1: 1 frame

*2: 20 ms

*3: 140 ms

*4: 100 ms

*5: 60 ms

HINT:

When the airbag system is deployed, after 1 frame of transmission indicating a normal condition is completed, the waveform on the left is repeated for 50 frames. After that, normal transmission returns.

HV

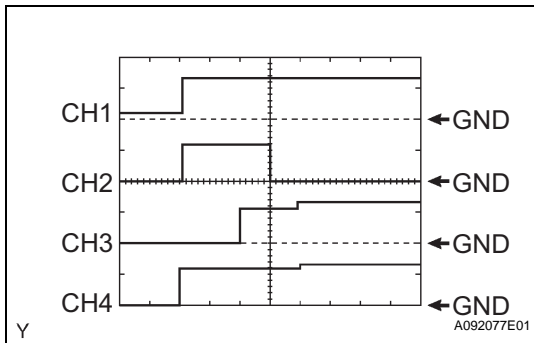

**10. Waveform 9
System main relay signal**

Item	Contents
Terminal	CH1: IGSW - GND1 CH2: CON1 - GND1 CH3: CON2 - GND1 CH4: CON3 - GND1
Equipment Setting	10 V/Division, 100 ms/Division
Condition	Power switch OFF to ON (READY)

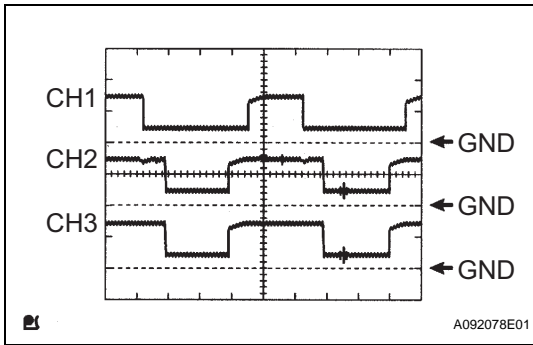

11. Waveform 10
Generator switch U, V, and W signal

Item	Contents
Terminal	CH1: GUU - GINV CH2: GVU - GINV CH3: GWU - GINV
Equipment Setting	10 V/Division, 20 μ s/Division
Condition	Power switch ON (IG)

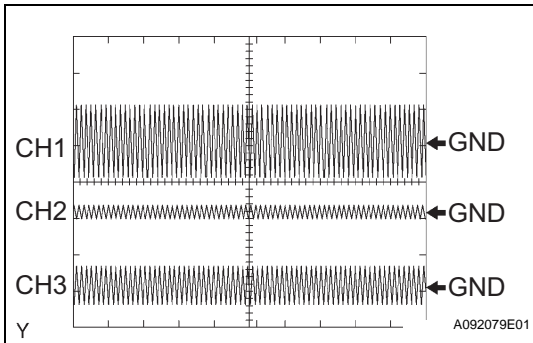

12. Waveform 11
Generator or motor resolver

Item	Contents
Terminal (Generator Resolver)	CH1: GRF - GRFG CH2: GSN - GSNG CH3: GCS - GCSG
Terminal (Motor Resolver)	CH1: MRF - MRFG CH2: MSN - MSNG CH3: MCS - MCSG
Equipment Setting	CH1: 10 V/Division, 1 ms/Division CH2, 3: 5 V/Division, 1 ms/Division
Condition	Generator or motor stopped

HINT:

The phases and the waveform height of the GSN and GCS, or the MSN and MCS change depending on the stopped position of the rotor.

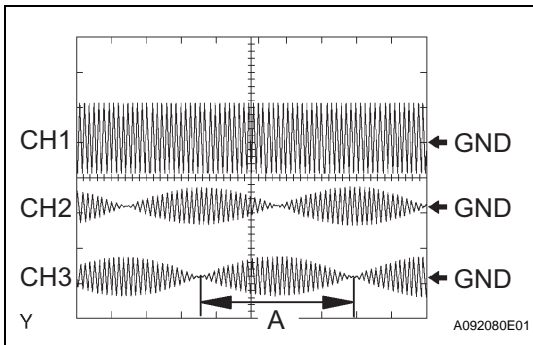

13. Waveform 12
Generator or motor resolver

Item	Contents
Terminal (Generator Resolver)	CH1: GRF - GRFG CH2: GSN - GSNG CH3: GCS - GCSG
Terminal (Motor Resolver)	CH1: MRF - MRFG CH2: MSN - MSNG CH3: MCS - MCSG
Equipment Setting	CH1: 10 V/Division, 1 ms/Division CH2, 3: 5 V/Division, 1 ms/Division
Condition	Generator or motor rotating

HINT:

Distance "A" in the diagram becomes shorter as the rotor speed increases.

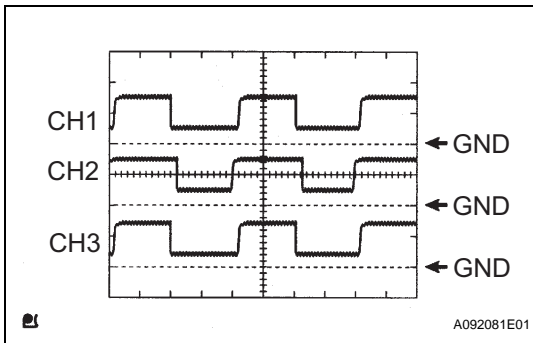

14. Waveform 13
Motor switch U, V, and W signal

Item	Contents
Terminal	CH1: MUU - GINV CH2: MVU - GINV CH3: MWU - GINV
Equipment Setting	10 V/Division, 50 μ s/Division
Condition	Power switch ON (IG)

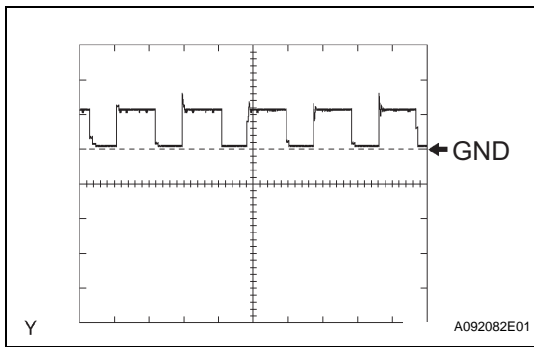

15. Waveform 14
Boost converter PWM switch signal

Item	Contents
Terminal	CPWM - GCNV
Equipment Setting	10 V/Division, 50 μ s/Division
Condition	Power switch ON (READY), parking brake ON, D position, brake pedal and accelerator pedal depressed

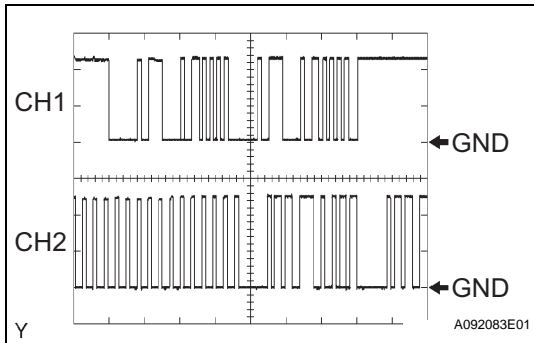

16. Waveform 15
Immobiliser communication

Item	Contents
Terminal	CH1: IMO - GND1 CH2: IMI - GND1
Equipment Setting	5 V/Division, 200 ms/Division
Condition	Immobiliser communicating

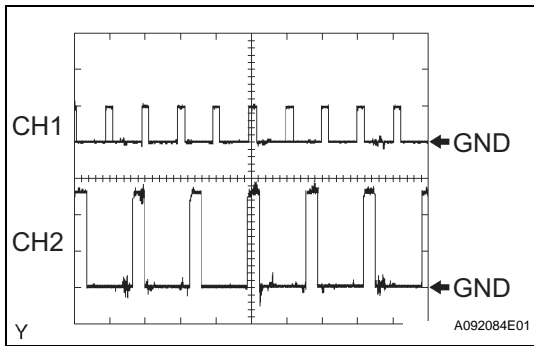

17. Waveform 16
P position control signal, P position signal

Item	Contents
Terminal	CH1: PCON - GND1 CH2: PPOS - GND1
Equipment Setting	5 V/Division, 20 ms/Division
Condition	Power switch ON (IG)

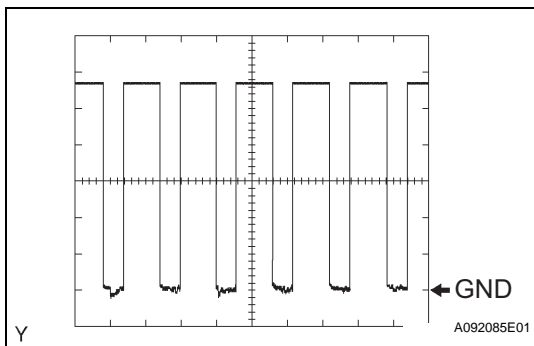

18. Waveform 17
READY control signal

Item	Contents
Terminal	RDY - GND1
Equipment Setting	2 V/Division, 20 ms/Division
Condition	Power switch ON (IG)

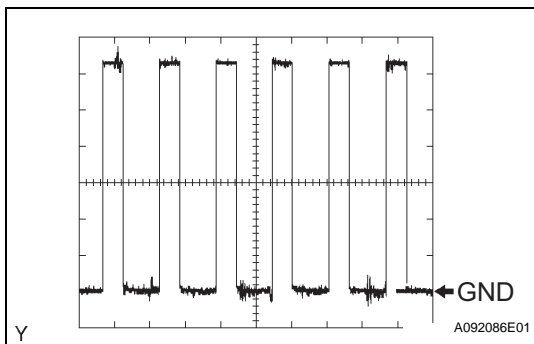

19. Waveform 18
READY control signal

Item	Contents
Terminal	RDY - GND1
Equipment Setting	2 V/Division, 20 ms/Division
Condition	Power switch ON (READY)

HV

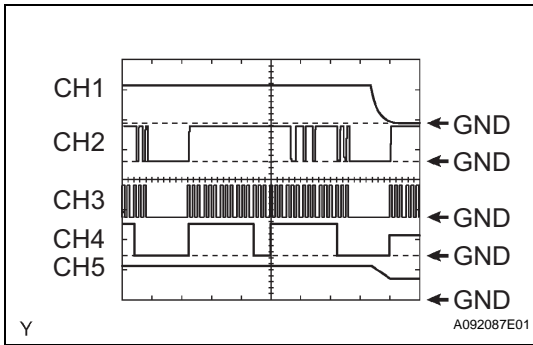

**20. Waveform 19
A/C communication**

Item	Contents
Terminal	CH1: IGSW - GND1 CH2: ITE - GND1 CH3: CLK - GND1 CH4: ETI - GND1 CH5: STB - GND1
Equipment Setting	10 V/Division, 50 ms/Division
Condition	Power switch ON (IG) and A/C operating



DIAGNOSIS SYSTEM

1. DESCRIPTION

- (a) The HV control ECU has a self-diagnosis system. If the computer, hybrid vehicle control system or the components are not working properly, the ECU carries out a diagnosis to detect the malfunctions, and illuminates the master warning light in the combination meter together with indicators on the multi display, the HV system warning, the HV battery warning or the discharge warning.

HINT:

The master warning light illuminates when THS II fails and it blinks when in inspection mode.

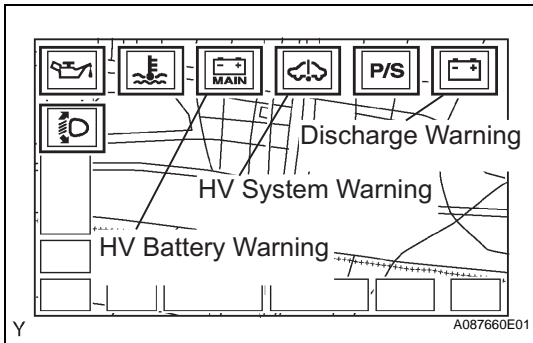

- When troubleshooting OBD II vehicles, the only difference from the usual troubleshooting procedure is that you need to connect the OBD II scan tool complying with ISO 15031-4 or the intelligent tester to the vehicle, and read various data output from the vehicle's ECUs
- OBD II regulations require that the vehicle's on-board computer illuminates the Malfunction Indicator Lamp (MIL) in the instrument panel when the computer detects a malfunction in: 1) the emission control systems/components, or 2) the powertrain control components (which affect vehicle emissions), or 3) the computers. In addition, the applicable Diagnostic Trouble Codes (DTCs) prescribed by ISO 15031-4 are recorded in the HV control ECU memory (see page HV-55).

If the malfunction does not recur in 3 consecutive trips, the MIL will go off automatically. However, the DTCs remain recorded in the HV control ECU memory.

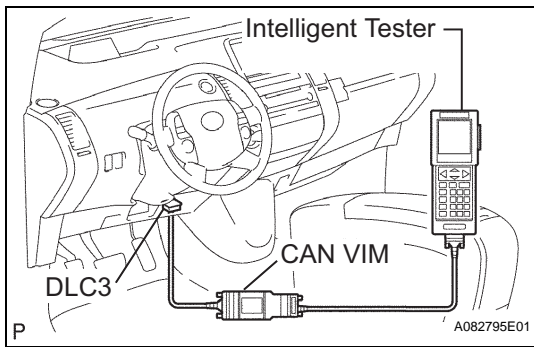

- To check the DTCs, connect the intelligent tester to the Data Link Connector 3 (DLC3) with the CAN vehicle interface module (CAN VIM). The intelligent tester enables you to erase the DTCs and check the freeze frame data and various forms of THS II data (for operating instructions, refer to their respective instruction manuals). The DTCs include SAE controlled codes and manufacturer controlled codes. SAE controlled codes must be set as prescribed by the SAE, while manufacturer controlled codes can be set by a manufacturer within the prescribed limits (see page HV-55).
- Freeze frame data:
The freeze frame data records the driving condition when malfunction is detected. When troubleshooting, it can help determine if the vehicle was moving, braking, stationary, or reversing.

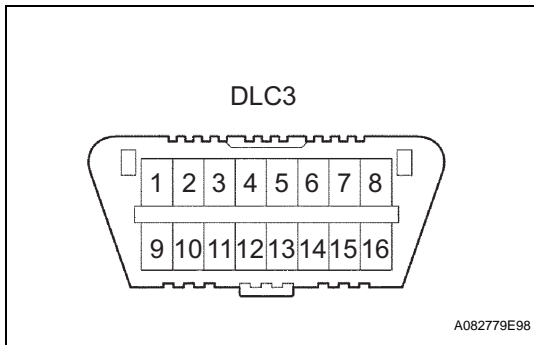

2. CHECK DLC3

The HV control ECU uses the ISO 15765-4 communication protocol. The terminal arrangement of the DLC3 complies with ISO 15031-03 and matches the ISO 15765-4 format.

HV

Symbol	Terminal No.	Name	Reference Terminal	Result	Condition
SIL	7	Bus "+" line	5 - Signal ground	Pulse generation	During transmission
CG	4	Chassis ground	Body ground	1 Ω or less	Always
SG	5	Signal ground	Body ground	1 Ω or less	Always
BAT	16	Battery positive	Body ground	11 to 14 V	Always
CANH	6	HIGH-level CAN bus line	14 - LOW-level CAN bus line	54 to 69 Ω	Power switch OFF*
CANH	6	HIGH-level CAN bus line	16 - Battery positive	1 MΩ or higher	Power switch OFF*
CANH	6	HIGH-level CAN bus line	4 - Chassis ground	200 Ω or higher	Power switch OFF*
CANL	14	LOW-level CAN bus line	16 - Battery positive	1 MΩ or higher	Power switch OFF*
CANL	14	LOW-level CAN bus line	4 - Chassis ground	200 Ω or higher	Power switch OFF*

NOTICE:

***: Before measuring the resistance, leave the vehicle as is for at least 1 minute and do not operate the power switch, other switches or doors.**

If the result is not as specified, the DLC3 may have a malfunction. Repair or replace the harness and connector.

HINT:

If the display shows **UNABLE TO CONNECT TO VEHICLE** when you have connected the cable of the intelligent tester to the DLC3, turned the power switch ON (IG) and operated the tester, there is a problem on the vehicle side or tester side.

- If communication is normal when the tester or scan tool is connected to another vehicle, inspect the DLC3 on the original vehicle.
- If communication is still not possible when the tester or scan tool is connected to another vehicle, the problem is probably in the tester or scan tool itself, so consult the Service Department listed in its instruction manual.

3. INSPECT AUXILIARY BATTERY

- (a) Measure the voltage of the auxiliary battery.

Standard voltage:

11 to 14 V

- (b) Inspect the auxiliary battery, fusible links, wire harness, connectors and ground.

4. CHECK MIL

- (a) The MIL illuminates when the power switch is turned ON (IG) and the "READY" light is OFF. If the MIL is not illuminated, troubleshoot the MIL circuit (see page [ES-428](#)).

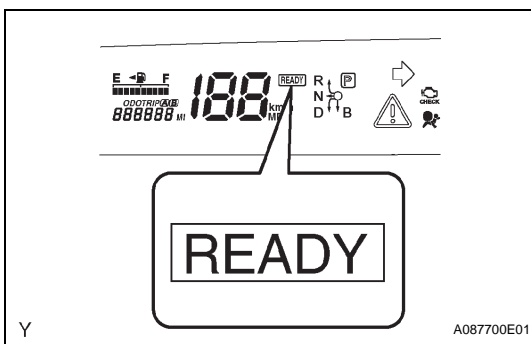

- (b) When the "READY" light turns on, the MIL should turn off. If the MIL remains on, the diagnosis system has detected a malfunction or abnormality in the system.

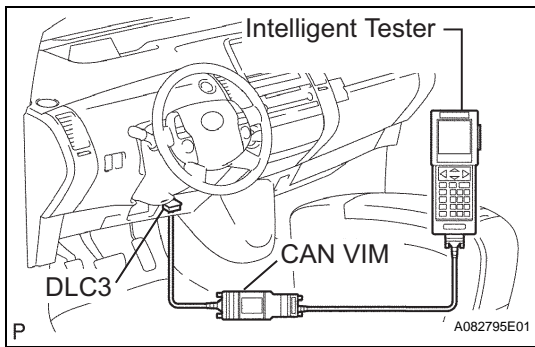

DTC CHECK / CLEAR

1. CHECK DTC (HV ECU)

- (a) Connect the intelligent tester to the DLC3.
- (b) Turn the power switch ON (IG) and turn the intelligent tester ON.
- (c) Using the intelligent tester, check the DTCs and freeze frame data and then write them down.
For the intelligent tester, enter the following menus: DIAGNOSIS / OBD/MOBD / HV ECU / DTC INFO / CURRENT CODES.
- (d) Confirm the details of the DTCS (see page [HV-55](#)).

2. CHECK FREEZE DATA AND INFORMATION

- (a) If a DTC is present, select that DTC in order to display its freeze frame data.

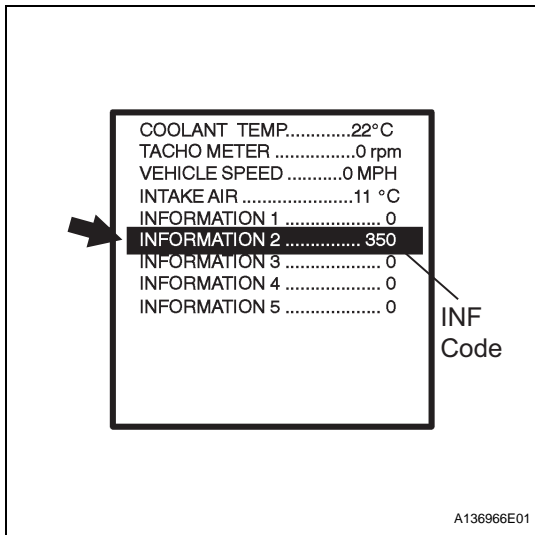
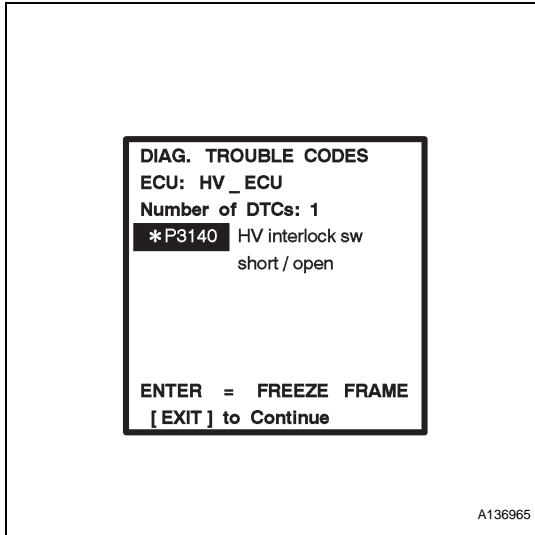

- (b) Read freeze frame data recorded when the DTC was set.

NOTICE:

An information code (INF code) is displayed in one of the INFORMATION lines 1 to 5. Check the details by following the procedures in the following steps.

HINT:

In the case shown in the illustration, refer to troubleshooting for DTC P3140 and INF code 350.

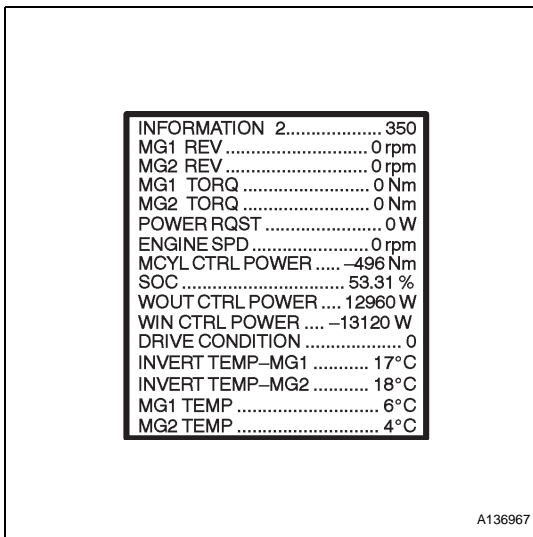
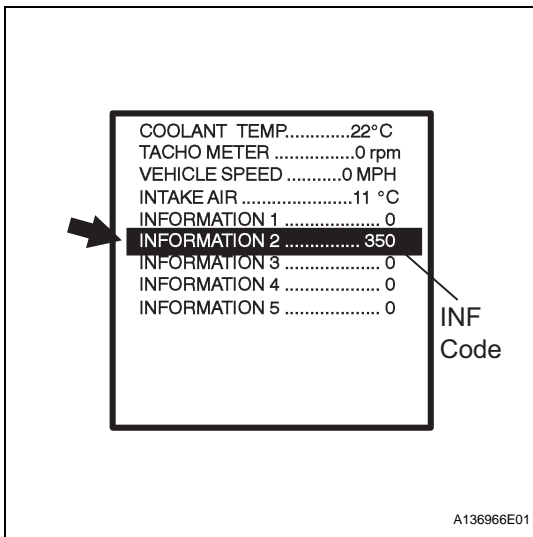

- (c) Read the information.
 - (1) Select the item that has an INF code from among INFORMATION 1 to 5 on the freeze frame data screen.
 - (2) Press ENTER.

(3) Information is displayed as shown in the illustration.

3. CHECK DTC (SYSTEMS OTHER THAN HV ECU)

HINT:

The HV control ECU maintains mutual communication with the computers, including the ECM, battery ECU, skid control ECU, power steering ECU and other components. Therefore, if the HV control ECU outputs a warning, it is necessary to check and record the DTCs of all the systems.

- (a) Connect the intelligent tester to the DLC3.
- (b) Turn the power switch ON (IG) and turn the intelligent tester ON.
- (c) For the intelligent tester, enter the following menus: DIAGNOSIS / OBD/MOBD / CODES (ALL).
- (d) If DTCs are present, check the relevant systems.

HINT:

If DTCs for the CAN communication system are present in addition to other DTCs, first troubleshoot and repair any malfunctions in the CAN communication (see page CA-6).

4. CLEAR DTC

NOTICE:

Clearing the DTCs will also clear the freeze frame data, information (see page HV-86) and operation history data (see page HV-89).

- (a) Connect the intelligent tester to the DLC3.
- (b) Turn the power switch ON (IG) and turn the intelligent tester ON.
- (c) Check that the shift position is in P.
- (d) Clear DTCs and freeze frame data with the intelligent tester.

For the intelligent tester:

- (1) Enter the following menus: DIAGNOSIS / OBD / MOBD / HV ECU / DTC INFO / CLEAR CODES.
- (2) Press YES.

FAIL-SAFE CHART

1. FAIL-SAFE CHART

DTC No.	Detection Item	INF Code	Driving Condition
B2799	Immobiliser malfunction	539	Impossible to drive
B2799	Immobiliser malfunction	540	Impossible to drive
B2799	Immobiliser malfunction	541	Impossible to drive
B2799	Immobiliser malfunction	542	Impossible to drive
B2799	Immobiliser malfunction	543	Impossible to drive
B2799	Immobiliser malfunction	544	Impossible to drive
P0336	Crankshaft Position Sensor "A" Circuit Range / Performance	137	Normal driving
P0338	Crankshaft Position Sensor "A" Circuit High Input	600	Normal driving
P0340	Camshaft Position Sensor "A" Circuit	532	Normal driving
P0343	Camshaft Position Sensor "A" Circuit High Input	601	Normal driving
P0500	Vehicle Speed Sensor "A"	352	Cruise control driving impossible
P0560	System Voltage	117	Normal driving
P0571	Brake Switch "A" Circuit	115	Cruise control driving impossible
P0607	Control Module Performance	116	Cruise control driving impossible
P0705	Transmission Range Sensor Circuit	571	If shift position cannot be fixed: Impossible to drive If shift position is being fixed: Normal driving
P0705	Transmission Range Sensor Circuit	572	If shift position cannot be fixed: Impossible to drive If shift position is being fixed: Normal driving
P0705	Transmission Range Sensor Circuit	573	If shift position cannot be fixed: Impossible to drive If shift position is being fixed: Normal driving
P0705	Transmission Range Sensor Circuit	574	If shift position cannot be fixed: Impossible to drive If shift position is being fixed: Normal driving
P0705	Transmission Range Sensor Circuit	575	If shift position cannot be fixed: Impossible to drive If shift position is being fixed: Normal driving
P0705	Transmission Range Sensor Circuit	576	If shift position cannot be fixed: Impossible to drive If shift position is being fixed: Normal driving
P0705	Transmission Range Sensor Circuit	577	If shift position cannot be fixed: Impossible to drive If shift position is being fixed: Normal driving
P0705	Transmission Range Sensor Circuit	578	If shift position cannot be fixed: Impossible to drive If shift position is being fixed: Normal driving
P0705	Transmission Range Sensor Circuit	595	If shift position cannot be fixed: Impossible to drive If shift position is being fixed: Normal driving

DTC No.	Detection Item	INF Code	Driving Condition
P0705	Transmission Range Sensor Circuit	596	If shift position cannot be fixed: Impossible to drive If shift position is being fixed: Normal driving
P0851	Park / Neutral Switch Input Circuit Low	579	If shift position cannot be fixed: Impossible to drive If shift position is being fixed: Normal driving
P0852	Park / Neutral Switch Input Circuit High	580	If shift position cannot be fixed: Impossible to drive If shift position is being fixed: Normal driving
P0A08	DC / DC Converter Status Circuit	264	Normal driving
P0A09	DC / DC Converter Status Circuit Low Input	265	Normal driving
P0A09	DC / DC Converter Status Circuit Low Input	591	Normal driving
P0A0D	High Voltage System Inter-lock Circuit High	350	Normal driving
P0A0D	High Voltage System Inter-lock Circuit High	351	Normal driving
P0A0F	Engine Failed to Start	204	Limited driving
P0A0F	Engine Failed to Start	205	Limited driving
P0A0F	Engine Failed to Start	238	Limited driving
P0A0F	Engine Failed to Start	533	Limited driving
P0A0F	Engine Failed to Start	534	Limited driving
P0A10	DC / DC Converter Status Circuit High Input	263	Normal driving
P0A10	DC / DC Converter Status Circuit High Input	592	Normal driving
P0A1D	Hybrid Powertrain Control Module	134	Impossible to drive
P0A1D	Hybrid Powertrain Control Module	135	Impossible to drive
P0A1D	Hybrid Powertrain Control Module	139	Normal driving
P0A1D	Hybrid Powertrain Control Module	140	Impossible to drive
P0A1D	Hybrid Powertrain Control Module	141	Impossible to drive
P0A1D	Hybrid Powertrain Control Module	142	Impossible to drive
P0A1D	Hybrid Powertrain Control Module	143	Impossible to drive
P0A1D	Hybrid Powertrain Control Module	144	Impossible to drive
P0A1D	Hybrid Powertrain Control Module	145	Impossible to drive
P0A1D	Hybrid Powertrain Control Module	148	Impossible to drive
P0A1D	Hybrid Powertrain Control Module	149	Impossible to drive
P0A1D	Hybrid Powertrain Control Module	150	Limited driving
P0A1D	Hybrid Powertrain Control Module	151	Limited driving
P0A1D	Hybrid Powertrain Control Module	152	Limited driving
P0A1D	Hybrid Powertrain Control Module	155	Limited driving
P0A1D	Hybrid Powertrain Control Module	156	Limited driving
P0A1D	Hybrid Powertrain Control Module	158	Limited driving
P0A1D	Hybrid Powertrain Control Module	159	Impossible to drive
P0A1D	Hybrid Powertrain Control Module	160	Impossible to drive
P0A1D	Hybrid Powertrain Control Module	163	Impossible to drive
P0A1D	Hybrid Powertrain Control Module	164	Impossible to drive
P0A1D	Hybrid Powertrain Control Module	165	Limited driving
P0A1D	Hybrid Powertrain Control Module	166	Normal driving
P0A1D	Hybrid Powertrain Control Module	167	Limited driving

DTC No.	Detection Item	INF Code	Driving Condition
P0A1D	Hybrid Powertrain Control Module	168	Limited driving
P0A1D	Hybrid Powertrain Control Module	177	Impossible to drive
P0A1D	Hybrid Powertrain Control Module	178	Impossible to drive
P0A1D	Hybrid Powertrain Control Module	180	Limited driving
P0A1D	Hybrid Powertrain Control Module	181	Limited driving
P0A1D	Hybrid Powertrain Control Module	182	Limited driving
P0A1D	Hybrid Powertrain Control Module	183	Limited driving
P0A1D	Hybrid Powertrain Control Module	184	Limited driving
P0A1D	Hybrid Powertrain Control Module	185	Limited driving
P0A1D	Hybrid Powertrain Control Module	186	Limited driving
P0A1D	Hybrid Powertrain Control Module	187	Impossible to drive
P0A1D	Hybrid Powertrain Control Module	188	Limited driving
P0A1D	Hybrid Powertrain Control Module	189	Limited driving
P0A1D	Hybrid Powertrain Control Module	192	Limited driving
P0A1D	Hybrid Powertrain Control Module	193	Limited driving
P0A1D	Hybrid Powertrain Control Module	195	Limited driving
P0A1D	Hybrid Powertrain Control Module	196	Limited driving
P0A1D	Hybrid Powertrain Control Module	197	Limited driving
P0A1D	Hybrid Powertrain Control Module	198	Normal driving
P0A1D	Hybrid Powertrain Control Module	199	Limited driving
P0A1D	Hybrid Powertrain Control Module	200	Limited driving
P0A1D	Hybrid Powertrain Control Module	390	Limited driving
P0A1D	Hybrid Powertrain Control Module	392	Impossible to drive
P0A1D	Hybrid Powertrain Control Module	393	Impossible to drive
P0A1D	Hybrid Powertrain Control Module	511	Impossible to drive
P0A1D	Hybrid Powertrain Control Module	512	Impossible to drive
P0A1D	Hybrid Powertrain Control Module	564	Limited driving
P0A1D	Hybrid Powertrain Control Module	565	Limited driving
P0A1D	Hybrid Powertrain Control Module	567	Impossible to drive
P0A1D	Hybrid Powertrain Control Module	568	Limited driving
P0A1D	Hybrid Powertrain Control Module	569	Limited driving
P0A1D	Hybrid Powertrain Control Module	570	Impossible to drive
P0A1D	Hybrid Powertrain Control Module	615	Limited driving
P0A1F	Battery Energy Control Module	123	Limited driving
P0A1F	Battery Energy Control Module	129	Limited driving
P0A1F	Battery Energy Control Module	593	Normal driving
P0A2B	Drive Motor "A" Temperature Sensor Circuit Range / Performance	248	Normal driving
P0A2B	Drive Motor "A" Temperature Sensor Circuit Range / Performance	250	Normal driving
P0A2C	Drive Motor "A" Temperature Sensor Circuit Low	247	Normal driving
P0A2D	Drive Motor "A" Temperature Sensor Circuit High	249	Normal driving
P0A37	Generator Temperature Sensor Circuit Range / Performance	258	Normal driving
P0A37	Generator Temperature Sensor Circuit Range / Performance	260	Normal driving
P0A38	Generator Temperature Sensor Circuit Low	257	Normal driving

DTC No.	Detection Item	INF Code	Driving Condition
P0A39	Generator Temperature Sensor Circuit High	259	Normal driving
P0A3F	Drive Motor "A" Position Sensor Circuit	243	Limited driving
P0A40	Drive Motor "A" Position Sensor Circuit Range / Performance	500	Limited driving
P0A41	Drive Motor "A" Position Sensor Circuit Low	245	Limited driving
P0A4B	Generator Position Sensor Circuit	253	Limited driving
P0A4C	Generator Position Sensor Circuit Range / Performance	513	Limited driving
P0A4D	Generator Position Sensor Circuit Low	255	Limited driving
P0A51	Drive Motor "A" Current Sensor Circuit	174	Limited driving
P0A60	Drive Motor "A" Phase V Current	288	Limited driving
P0A60	Drive Motor "A" Phase V Current	289	Limited driving
P0A60	Drive Motor "A" Phase V Current	290	Limited driving
P0A60	Drive Motor "A" Phase V Current	292	Limited driving
P0A60	Drive Motor "A" Phase V Current	294	Limited driving
P0A60	Drive Motor "A" Phase V Current	501	Limited driving
P0A63	Drive Motor "A" Phase W Current	296	Limited driving
P0A63	Drive Motor "A" Phase W Current	297	Limited driving
P0A63	Drive Motor "A" Phase W Current	298	Limited driving
P0A63	Drive Motor "A" Phase W Current	300	Limited driving
P0A63	Drive Motor "A" Phase W Current	302	Limited driving
P0A63	Drive Motor "A" Phase W Current	502	Limited driving
P0A72	Generator Phase V Current	326	Limited driving
P0A72	Generator Phase V Current	327	Limited driving
P0A72	Generator Phase V Current	328	Limited driving
P0A72	Generator Phase V Current	330	Limited driving
P0A72	Generator Phase V Current	333	Limited driving
P0A72	Generator Phase V Current	515	Limited driving
P0A75	Generator Phase W Current	334	Limited driving
P0A75	Generator Phase W Current	335	Limited driving
P0A75	Generator Phase W Current	336	Limited driving
P0A75	Generator Phase W Current	338	Limited driving
P0A75	Generator Phase W Current	341	Limited driving
P0A75	Generator Phase W Current	516	Limited driving
P0A78	Drive Motor "A" Inverter Performance	266	Limited driving
P0A78	Drive Motor "A" Inverter Performance	267	Limited driving
P0A78	Drive Motor "A" Inverter Performance	272	Normal driving
P0A78	Drive Motor "A" Inverter Performance	278	Normal driving
P0A78	Drive Motor "A" Inverter Performance	279	Limited driving
P0A78	Drive Motor "A" Inverter Performance	280	Normal driving
P0A78	Drive Motor "A" Inverter Performance	282	Limited driving

DTC No.	Detection Item	INF Code	Driving Condition
P0A78	Drive Motor "A" Inverter Performance	283	Normal driving
P0A78	Drive Motor "A" Inverter Performance	284	Limited driving
P0A78	Drive Motor "A" Inverter Performance	285	Normal driving
P0A78	Drive Motor "A" Inverter Performance	286	Limited driving
P0A78	Drive Motor "A" Inverter Performance	287	Limited driving
P0A78	Drive Motor "A" Inverter Performance	304	Normal driving
P0A78	Drive Motor "A" Inverter Performance	305	Normal driving
P0A78	Drive Motor "A" Inverter Performance	306	Limited driving
P0A78	Drive Motor "A" Inverter Performance	308	Impossible to drive
P0A78	Drive Motor "A" Inverter Performance	503	Limited driving
P0A78	Drive Motor "A" Inverter Performance	504	Limited driving
P0A78	Drive Motor "A" Inverter Performance	505	Limited driving
P0A78	Drive Motor "A" Inverter Performance	506	Limited driving
P0A78	Drive Motor "A" Inverter Performance	507	Normal driving
P0A78	Drive Motor "A" Inverter Performance	508	Normal driving
P0A78	Drive Motor "A" Inverter Performance	510	Normal driving
P0A78	Drive Motor "A" Inverter Performance	523	Limited driving
P0A78	Drive Motor "A" Inverter Performance	586	Limited driving
P0A7A	Generator Inverter Performance	309	Limited driving
P0A7A	Generator Inverter Performance	321	Normal driving
P0A7A	Generator Inverter Performance	322	Limited driving
P0A7A	Generator Inverter Performance	323	Normal driving
P0A7A	Generator Inverter Performance	324	Limited driving
P0A7A	Generator Inverter Performance	325	Limited driving
P0A7A	Generator Inverter Performance	342	Limited driving
P0A7A	Generator Inverter Performance	343	Limited driving
P0A7A	Generator Inverter Performance	344	Limited driving
P0A7A	Generator Inverter Performance	517	Limited driving
P0A7A	Generator Inverter Performance	518	Limited driving
P0A7A	Generator Inverter Performance	519	Limited driving
P0A7A	Generator Inverter Performance	520	Limited driving
P0A7A	Generator Inverter Performance	522	Normal driving
P0A90	Drive Motor "A" Performance	239	Limited driving
P0A90	Drive Motor "A" Performance	240	Limited driving
P0A90	Drive Motor "A" Performance	241	Limited driving
P0A90	Drive Motor "A" Performance	242	Limited driving
P0A90	Drive Motor "A" Performance	251	Limited driving

DTC No.	Detection Item	INF Code	Driving Condition
P0A90	Drive Motor "A" Performance	509	Limited driving
P0A90	Drive Motor "A" Performance	602	Limited driving
P0A90	Drive Motor "A" Performance	604	Limited driving
P0A90	Drive Motor "A" Performance	605	Limited driving
P0A92	Hybrid Generator Performance	261	Limited driving
P0A92	Hybrid Generator Performance	521	Limited driving
P0A92	Hybrid Generator Performance	606	Limited driving
P0A92	Hybrid Generator Performance	607	Limited driving
P0A93	Inverter Cooling System Performance	346	Limited driving
P0A93	Inverter Cooling System Performance	347	Limited driving
P0A94	DC / DC Converter Performance	442	Limited driving
P0A94	DC / DC Converter Performance	545	Limited driving
P0A94	DC / DC Converter Performance	546	Limited driving
P0A94	DC / DC Converter Performance	547	Limited driving
P0A94	DC / DC Converter Performance	548	Limited driving
P0A94	DC / DC Converter Performance	549	Limited driving
P0A94	DC / DC Converter Performance	550	Limited driving
P0A94	DC / DC Converter Performance	551	Limited driving
P0A94	DC / DC Converter Performance	552	Limited driving
P0A94	DC / DC Converter Performance	553	Limited driving
P0A94	DC / DC Converter Performance	554	Limited driving
P0A94	DC / DC Converter Performance	555	Limited driving
P0A94	DC / DC Converter Performance	556	Limited driving
P0A94	DC / DC Converter Performance	557	Limited driving
P0A94	DC / DC Converter Performance	558	Normal driving
P0A94	DC / DC Converter Performance	559	Limited driving
P0A94	DC / DC Converter Performance	560	Normal driving
P0A94	DC / DC Converter Performance	561	Limited driving
P0A94	DC / DC Converter Performance	583	Normal driving
P0A94	DC / DC Converter Performance	584	Normal driving
P0A94	DC / DC Converter Performance	585	Normal driving
P0A94	DC / DC Converter Performance	587	Limited driving
P0A94	DC / DC Converter Performance	588	Limited driving
P0A94	DC / DC Converter Performance	589	Normal driving
P0A94	DC / DC Converter Performance	590	Normal driving
P0AA1	Hybrid Battery Positive Contactor Circuit Stuck Closed	231	Impossible to drive
P0AA1	Hybrid Battery Positive Contactor Circuit Stuck Closed	233	Impossible to drive
P0AA4	Hybrid Battery Negative Contactor Circuit Stuck Closed	232	Limited driving
P0AA6	Hybrid Battery Voltage System Isolation Fault	526	Normal driving*
P0AA6	Hybrid Battery Voltage System Isolation Fault	611	Normal driving*
P0AA6	Hybrid Battery Voltage System Isolation Fault	612	Normal driving*
P0AA6	Hybrid Battery Voltage System Isolation Fault	613	Normal driving*

DTC No.	Detection Item	INF Code	Driving Condition
P0AA6	Hybrid Battery Voltage System Isolation Fault	614	Normal driving*
P0ADB	Hybrid Battery Positive Contactor Control Circuit Low	227	Impossible to drive
P0ADC	Hybrid Battery Positive Contactor Control Circuit High	226	Impossible to drive
P0ADF	Hybrid Battery Negative Contactor Control Circuit Low	229	Impossible to drive
P0AE0	Hybrid Battery Negative Contactor Control Circuit High	228	Impossible to drive
P0AE6	Hybrid Battery Precharge Contactor Control Circuit Low	225	Normal driving
P0AE7	Hybrid Battery Precharge Contactor Control Circuit High	224	Normal driving
P0AEE	Motor Inverter Temperature Sensor "A" Circuit Range / Performance	276	Normal driving
P0AEE	Motor Inverter Temperature Sensor "A" Circuit Range / Performance	277	Normal driving
P0AEF	Drive Motor Inverter Temperature Sensor "A" Circuit Low	275	Normal driving
P0AF0	Drive Motor Inverter Temperature Sensor "A" Circuit High	274	Normal driving
P2120	Throttle / Pedal Position Sensor / Switch "D" Circuit	111	Limited driving
P2121	Throttle / Pedal Position Sensor / Switch "D" Circuit Range / Performance	106	Limited driving
P2121	Throttle / Pedal Position Sensor / Switch "D" Circuit Range / Performance	114	Limited driving
P2122	Throttle / Pedal Position Sensor / Switch "D" Circuit Low Input	104	Limited driving
P2123	Throttle / Pedal Position Sensor / Switch "D" Circuit High Input	105	Limited driving
P2125	Throttle / Pedal Position Sensor / Switch "E" Circuit	112	Limited driving
P2126	Throttle / Pedal Position Sensor / Switch "E" Circuit Range / Performance	109	Limited driving
P2127	Throttle / Pedal Position Sensor / Switch "E" Circuit Low Input	107	Limited driving
P2128	Throttle / Pedal Position Sensor / Switch "E" Circuit High Input	108	Limited driving
P2138	Throttle / Pedal Position Sensor / Switch "D" / "E" Voltage Correlation	110	Limited driving
P3000	HV Battery Malfunction	123	Limited driving
P3000	HV Battery Malfunction	125	Limited driving
P3000	HV Battery Malfunction	388	Limited driving
P3000	HV Battery Malfunction	389	Limited driving
P3000	HV Battery Malfunction	603	Limited driving
P3004	Power Cable Malfunction	131	Impossible to drive
P3004	Power Cable Malfunction	132	Normal driving
P3004	Power Cable Malfunction	133	Limited driving

DTC No.	Detection Item	INF Code	Driving Condition
P3102	Transmission Control ECU Malfunction	524	Impossible to drive
P3102	Transmission Control ECU Malfunction	525	Impossible to drive
P3102	Transmission Control ECU Malfunction	581	If shift position cannot be fixed: Impossible to drive If shift position is being fixed: Normal driving
P3102	Transmission Control ECU Malfunction	582	If shift position cannot be fixed: Impossible to drive If shift position is being fixed: Normal driving
P3102	Transmission Control ECU Malfunction	597	If shift position cannot be fixed: Impossible to drive If shift position is being fixed: Normal driving
P3102	Transmission Control ECU Malfunction	598	If shift position cannot be fixed: Impossible to drive If shift position is being fixed: Normal driving
P3102	Transmission Control ECU Malfunction	599	If shift position cannot be fixed: Impossible to drive If shift position is being fixed: Normal driving
P3107	Airbag ECU Communication Circuit Malfunction	213	Normal driving
P3107	Airbag ECU Communication Circuit Malfunction	214	Normal driving
P3107	Airbag ECU Communication Circuit Malfunction	215	Normal driving
P3108	A/C Amplifier Communication Circuit Malfunction	535	Normal driving
P3108	A/C Amplifier Communication Circuit Malfunction	536	Normal driving
P3108	A/C Amplifier Communication Circuit Malfunction	537	Normal driving
P3108	A/C Amplifier Communication Circuit Malfunction	538	Normal driving
P3108	A/C Amplifier Communication Circuit Malfunction	594	Normal driving
P3110	IGCT Relay Malfunction	223	Normal driving
P3110	HV Main Relay Malfunction	527	Impossible to drive
P3137	Collision Sensor Low Input	348	Normal driving
P3138	Collision Sensor High Input	349	Normal driving
P3221	Generator Inverter Temperature Sensor Circuit Range / Performance	314	Normal driving
P3221	Generator Inverter Temperature Sensor Circuit Range / Performance	315	Normal driving
P3222	Generator Inverter Temperature Sensor Circuit High / Low	313	Normal driving
P3223	Generator Inverter Temperature Sensor Circuit High	312	Normal driving
P3226	DC / DC Boost Converter Temperature Sensor Malfunction	562	Normal driving
P3226	DC / DC Boost Converter Temperature Sensor Malfunction	563	Normal driving

DTC No.	Detection Item	INF Code	Driving Condition
U0100	Lost Communication with ECM / PCM "A"	211	Limited driving
U0100	Lost Communication with ECM / PCM "A"	212	Limited driving
U0100	Lost Communication with ECM / PCM "A"	530	Limited driving
U0111	Lost Communication with Battery Energy Control Module "A"	208	Limited driving
U0111	Lost Communication with Battery Energy Control Module "A"	531	Limited driving
U0129	Lost Communication with Brake System Control Module	220	Regenerative brake ineffective
U0129	Lost Communication with Brake System Control Module	222	Regenerative brake ineffective
U0129	Lost Communication with Brake System Control Module	528	Regenerative brake ineffective
U0129	Lost Communication with Brake System Control Module	529	Regenerative brake ineffective
U0131	Lost Communication with Power Steering Control Module	433	Normal driving
U0131	Lost Communication with Power Steering Control Module	434	Normal driving
U0146	Lost Communication with Gateway "A"	435	Normal driving

HINT:

*: Normal driving occurs but turning the power switch OFF once causes driving to become impossible.

DATA LIST / ACTIVE TEST

1. DATA LIST

NOTICE:

- The value of the DATA LIST may vary significantly if there are slight differences in measurement, differences in the environment in which the measurements are obtained, or the aging of the vehicle. Thus, definite standards or judgment values are unavailable. Therefore, there may be a malfunction even if a measured value is within the reference range.
- In the event of intricate symptoms, collect sample data from another vehicle of the same model operating under identical conditions, in order to reach an overall judgment by comparing all the items of DATA LIST.

HINT:

Using the DATA LIST displayed on the intelligent tester, you can read values including those of the switches, sensors, actuators, without removing any parts. Reading the DATA LIST as the first step of troubleshooting is one method to shorten diagnostic time.

- Connect the intelligent tester to the DLC3.
- Turn the power switch ON (IG).
- Turn the intelligent tester ON.
- Enter the following menus: DIAGNOSIS / OBD/ MOBD / HV ECU / DATA LIST.
- Check the results by referring to the following table.

Intelligent Tester Display	Measurement Item / Range (Display)	Reference Range	Diagnostic Note
COOLANT TEMP	Engine coolant temperature / Min.: -40°C, Max.: 140°C	After warming up: 80 to 100°C (176 to 212°F)	<ul style="list-style-type: none"> • The value is -40°C (-40°F): Open in sensor circuit • If the value is 140°C (284°F): Short in sensor circuit
VEHICLE SPD	Vehicle speed / Min.: 0 km/h, Max.: 255 km/h	Vehicle stopped: 0 km/h (0 mph)	-
ENG RUN TIME	Elapsed time after starting engine / Min.: 0 s, Max.: 65,535 s	-	-
+B	Auxiliary battery voltage / Min.: 0 V, Max.: 65.535 V	Constant: Auxiliary battery voltage +3 V	-
ACCEL POS #1	No. 1 accelerator pedal position sensor / Min.: 0%, Max.: 100%	Accelerator pedal depressed: Changes with accelerator pedal pressure	-
ACCEL POS #2	No. 2 accelerator pedal position sensor / Min.: 0%, Max.: 100%	Accelerator pedal depressed: Changes with accelerator pedal pressure	-
AMBIENT TEMP	Ambient air temperature / Min.: -40°C, Max.: 215°C	Power switch ON (IG): Same as ambient air temperature	-
INTAKE AIR TEMP	Intake air temperature / Min.: -40°C, Max.: 140°C	Constant: Same as ambient air temperature	-
DTC CLEAR WARM	The number of times engine is warmed up after clearing DTCs / Min.: 0, Max.: 255	MIL OFF, engine coolant temperature increases from below 22°C (71.6°F) before starting the engine to above 70°C (158°F) after starting the engine: Increases once	-

Intelligent Tester Display	Measurement Item / Range (Display)	Reference Range	Diagnostic Note
DTC CLEAR RUN	Drive distance after clearing DTCs / Min.: 0 km, Max.: 65,535 km	-	-
DTC CLEAR MIN	Elapsed time after clearing DTCs / Min.: 0 min, Max.: 65,535 min	-	-
MIL ON RUN DIST	Drive distance after malfunction occurrence / Min.: 0 km, Max.: 65,535 km	-	-
MIL ON ENG TIME	Elapsed time after starting engine with MIL ON / Min.: 0 min, Max.: 65,535 min	-	-
MIL Status	MIL status / ON or OFF	MIL ON: ON	Constant ON: Repair in accordance with detected DTCs
MG2 REV	MG2 revolution / Min.: -16,383 rpm, Max.: 16,383 rpm	-	-
MG2 TORQ	MG2 torque / Min.: -500 Nm, Max.: 500 Nm	-	-
MG2 TRQ EXC VAL	MG2 torque execution value / Min.: -512 Nm, Max.: 508 Nm	After full-load acceleration with READY light ON and engine stopped: Less than +20% of MG2 TORQ	-
MG1 REV	MG1 revolution / Min.: -16,383 rpm, Max.: 16,383 rpm	-	-
MG1 TORQ	MG1 torque / Min.: -500 Nm, Max.: 500 Nm	-	-
MG1 TRQ EXC VAL	MG1 torque execution value / Min.: -512 Nm, Max.: 508 Nm	1 second has elapsed after the engine was started automatically with READY light ON, engine stopped, A/C fan Hi, headlight ON and the P position: Less than +20% of MG1 TORQ	-
REGEN EXEC TORQ	Regenerative brake execution torque / Min.: 0 Nm, Max.: 186 Nm	-	-
REGEN RQST TORQ	Regenerative brake request torque / Min.: 0 Nm, Max.: 186 Nm	Vehicle speed 30 km/h (19 mph) and master cylinder hydraulic pressure -200 Nm: Changes with brake pedal pressure	-
MG1 INVERT TEMP	MG1 inverter temperature / Min.: -50°C, Max.: 205°C	<ul style="list-style-type: none"> Undisturbed for 1 day at 25°C (77°F): 25°C (77°F) Street driving: 25 to 80°C (77 to 176°F) 	<ul style="list-style-type: none"> If the value is -50°C (-58°F): +B short in sensor circuit If the value is 205°C (401°F): Open or GND short in sensor circuit
MG2 INVERT TEMP	MG2 inverter temperature / Min.: -50°C, Max.: 205°C	<ul style="list-style-type: none"> Undisturbed for 1 day at 25°C (77°F): 25°C (77°F) Street driving: 25 to 80°C (77 to 176°F) 	<ul style="list-style-type: none"> If the value is -50°C (-58°F): +B short in sensor circuit If the value is 205°C (401°F): Open or GND short in sensor circuit
MOTOR2 TEMP	Transaxle fluid temperature / Min.: -50°C, Max.: 205°C	<ul style="list-style-type: none"> Undisturbed for 1 day at 25°C (77°F): 25°C (77°F) Street driving: 25 to 80°C (77 to 176°F) 	<ul style="list-style-type: none"> If the value is -50°C (-58°F): Open or +B short in sensor circuit If the value is 205°C (401°F): GND short in sensor circuit

Intelligent Tester Display	Measurement Item / Range (Display)	Reference Range	Diagnostic Note
MOTOR1 TEMP	MG2 motor temperature / Min.: -50°C, Max.: 205°C	<ul style="list-style-type: none"> Undisturbed for 1 day at 25°C (77°F): 25°C (77°F) Street driving: 25 to 80°C (77 to 176°F) 	<ul style="list-style-type: none"> If the value is -50°C (-58°F): Open or +B short in sensor circuit If the value is 205°C (401°F): GND short in sensor circuit
CONVERTER TEMP	Boost converter temperature / Min.: -50°C, Max.: 205°C	<ul style="list-style-type: none"> Undisturbed for 1 day at 25°C (77°F): 25°C (77°F) Street driving: 25 to 60°C (77 to 140°F) 	<ul style="list-style-type: none"> If the value is -50°C (-58°F): +B short in sensor circuit If the value is 205°C (401°F): Open or GND short in sensor circuit
ACCEL DEG	Accelerator pedal depressed angle / Min.: 0%, Max.: 100%	Accelerator pedal depressed: Changes with accelerator pedal pressure	-
POWER RQST	Engine power output request value / Min.: 0 W, Max.: 320,000 W	-	-
TARGET ENG SPD	Target engine speed / Min.: 0 rpm, Max.: 8,000 rpm	-	-
ENGINE SPD	Engine speed / Min.: 0 rpm, Max.: 8,000 rpm	Idling*: 950 to 1,050 rpm	-
VEHICLE SPD	Resolver vehicle speed / Min.: -256 km/h, Max.: 254 km/h	Driving at 40 km/h (25 mph): 40 km/h (25 mph)	-
MCYL CTRL POWER	Braking torque that is equivalent to the master cylinder hydraulic pressure / Min.: -512 Nm, Max.: 508 Nm	Brake pedal depressed: Changes with brake pedal pressure	-
SOC	Battery state of charge / Min.: 0%, Max.: 100%	Constant: 0 to 100%	-
WOUT CTRL POWER	Discharge control power value / Min.: 0 W, Max.: 81,600 W	21,000 W or less	-
WIN CTRL POWER	Charge control power value / Min.: -40,800 W, Max.: 0 W	-25,000 W or more	-
DCHG RQST SOC	Discharge request to adjust SOC / Min.: -20,480 W, Max.: 20,320 W	<ul style="list-style-type: none"> Uniform on-board charging: -4,400 W Usually: 0 W 	-
PWR RESOURCE VB	HV battery voltage / Min.: 0 V, Max.: 510 V	READY light ON and P position: 150 to 300 V	-
PWR RESOURCE IB	HV battery current / Min.: -256 A, Max.: 254 A	-	-
VL	High voltage before it is boosted / Min.: 0 V, Max.: 510 V	Power switch ON (READY): Practically the same as the HV battery voltage	<ul style="list-style-type: none"> If the value is 0 V: Open or GND short in sensor circuit If the value is 510 V: +B short in sensor circuit
VH	High voltage after it is boosted / Min.: 0 V, Max.: 765 V	Engine revved up in P position: HV battery voltage to 500 V	<ul style="list-style-type: none"> If the value is 0 V: Open or GND short in sensor circuit If the value is 765 V: +B short in sensor circuit
RAIS PRES RATIO	Boost ratio / Min.: 0%, Max.: 100%	The pre-boost voltage and the post-boost voltage are equal: 0 to 10%	-
DRIVE CONDITION	Drive condition ID / Min.: 0, Max.: 6	<ul style="list-style-type: none"> Engine stopped: 0 Engine about to be stopped: 1 Engine about to be started: 2 Engine operated or operating: 3 Generating or loading movement: 4 Revvng up with P position: 6 	-

Intelligent Tester Display	Measurement Item / Range (Display)	Reference Range	Diagnostic Note
M SHIFT SENSOR	Output voltage of the shift position sensor (main) / Min.: 0 V, Max.: 5 V	<ul style="list-style-type: none"> Selector lever in home position: 2.0 to 3.0 V Shifting into R position: 4.0 to 4.8 V Shifting into B or D position: 0.2 to 1.0 V 	-
S SHIFT SENSOR	Output voltage of the shift position sensor (sub) / Min.: 0 V, Max.: 5 V	<ul style="list-style-type: none"> Selector lever in home position: 2.0 to 3.0 V Shifting into R position: 4.0 to 4.8 V Shifting into B or D position: 0.2 to 1.0 V 	-
SM SHIFT SENSOR	Output voltage of the select position sensor (main) / Min.: 0 V, Max.: 5 V	<ul style="list-style-type: none"> Selector lever in home position: 0.5 to 2.0 V Shifting into R, N or D position: 3.0 to 4.85 V 	-
SS SHIFT SENSOR	Output voltage of the select position sensor (sub) / Min.: 0 V, Max.: 5 V	<ul style="list-style-type: none"> Selector lever in home position: 0.5 to 2.0 V Shifting into R, N or D position: 3.0 to 4.85 V 	-
SHIFT POSITION	Shift position	P, R, N, D or B	-
A/C CONSMPT PWR	A/C consumption power / Min.: 0 kW, Max.: 5 kW	-	-
DRIVE CONDITION	Driving condition	<ul style="list-style-type: none"> MG1 load: MG1 MG2 load: MG2 	-
SHORT WAVE HIGH	Waveform voltage in leak detection circuit in battery ECU / Min.: 0 V, Max.: 5 V	READY light is left ON for 2 minutes, and the pre-boost voltage and the post-boost voltage are equal: 4 V or more	-
ECU TYPE	Type of ECU	HV ECU	-
CURRENT DTC	The number of current DTCs / Min.: 0, Max.: 255	-	-
HISTORY DTC	The number of history DTCs / Min.: 0, Max.: 255	-	-
CHECK MODE	Check mode / ON or OFF	-	-
ENG STOP RQST	Engine stop request / NO or RQST	Requesting engine stop: RQST	-
IDLING REQUEST	Engine idling request / NO or RQST	Requesting idle: RQST	-
HV BATT CH RQST	HV battery charging request / NO or RQST	Requesting HV battery charging: RQST	-
AIRCON REQUEST	Engine starting request from air conditioning amplifier / NO or RQST	Requesting engine start from air conditioning amplifier: RQST	-
ENG WARM UP RQT	Engine warm-up request / NO or RQST	Requesting engine warm-up: RQST	-
SMR CONT1	Operating condition of No. 1 system main relay / ON or OFF	Power switch ON (READY): OFF	-
SMR CONT2	Operating condition of No. 2 system main relay / ON or OFF	Power switch ON (READY): ON	-

Intelligent Tester Display	Measurement Item / Range (Display)	Reference Range	Diagnostic Note
SMR CONT3	Operating condition of No. 3 system main relay / ON or OFF	Power switch ON (READY): ON	-
MG1 GATE	MG1 gate status / ON or OFF	ON	-
MG2 GATE	MG2 gate status / ON or OFF	Shutting down motor inverter: ON	-
CNV GATE	Boost converter gate status / ON or OFF	Shutting down boost converter: ON	-
A/C GATE	A/C gate status / ON or OFF	Shutting down A/C inverter: ON	-
ENTRY KEY ECU	Electronic key ID code check status / ON or OFF	When electronic key ID code corresponds to ID code registered in ECU: ON	-

HINT:

*: If no conditions are specifically stated for "Idling", it means the engine for inspection mode, the shift position is in P, the A/C switch is OFF, and accelerator pedal is not depressed.

2. **ACTIVE TEST**

NOTICE:

Beware that if the connector to the intelligent tester becomes disconnected or a communication error occurs during the ACTIVE TEST, the vehicle could become inoperative (READY light OFF).

HINT:

Performing the ACTIVE TEST using the intelligent tester enables components including the relay, VSV, and actuator, to be operated without removing any parts. Performing the ACTIVE TEST as the first step of troubleshooting is one method to shorten diagnostic time.

It is possible to display items in the DATA LIST during the ACTIVE TEST.

- (a) Connect the intelligent tester to the DLC3.
- (b) Turn the power switch ON (IG).
- (c) Turn the intelligent tester ON.
- (d) Enter the following menus: DIAGNOSIS / OBD/ MOBD / HV ECU / ACTIVE TEST.
- (e) According to the display on the tester, perform the ACTIVE TEST.

Intelligent Tester Display	Purpose	Test Details	Test Condition
INSPECTION MOD1*1, *2	<ul style="list-style-type: none"> • To check its operation while the engine is running • To disable traction control while performing a speedometer test or other test 	<ul style="list-style-type: none"> • Runs the engine continuously (P position) • Cancels the traction control that is effected when the rotational difference between the front and rear wheels is excessive (other than the P position) 	Power switch ON (IG), HV system normal, not in inspection mode, and other Active Tests not being executed

Intelligent Tester Display	Purpose	Test Details	Test Condition
INSPECTION MOD2*1, *2	To disable traction control while performing a speedometer test or the like	Cancels the traction control that is effected when the rotational difference between the front and rear wheels is excessive (other than the P position)	Power switch ON (IG), HV system normal, not in inspection mode, and other Active Tests not being executed
INVERTER STOP*1	To determine if there is an internal leak in the inverter or the HV control ECU	Keeps the inverter power transistor actuation signal ON	Power switch ON (IG), P position, HV system normal, inverter actuation not being disabled, shutting down inverter, and other Active Tests not being executed
COMPRESS TEST*1, *3, *4	To crank the engine continuously in order to measure the compression	Allows the engine to continue cranking by activating the generator continuously	Power switch ON (IG), HV system normal, not in cranking mode, and other Active Tests not being executed

NOTICE:

***1: The intelligent tester displays a communication error and the vehicle's READY light turns OFF when the ACTIVE TEST is completed. Therefore, in order to use the tester again, turn the power switch OFF, and restart by turning it ON.**

***2: After turning on INSPECTION MOD1 or MOD2, push the power switch while depressing the brake pedal.**

***3: After turning on COMPRESS TEST, push the power switch while depressing the brake pedal. To stop engine cranking, push the power switch again.**

***4: COMPRESS TEST may not be activated depending on the condition of the engine or the HV battery.**

DIAGNOSTIC TROUBLE CODE CHART

DTC No.	Detection Item	DTC Detection Condition	Trouble Area	Master Warning Light	MIL	Memory	See page
P0336-137	Crankshaft Position Sensor "A" Circuit Range / Performance	Engine speed sensor deviation malfunction (CAN communication)	- Wire harness or connector - Crankshaft position sensor - Camshaft position sensor - HV control ECU	Comes on	-	DTC stored	HV-91
P0338-600	Crankshaft Position Sensor "A" Circuit High Input	NEO signal circuit malfunction	- Wire harness or connector - HV control ECU	Comes on	-	DTC stored	HV-94
P0340-532	Camshaft Position Sensor "A" Circuit	Engine speed sensor deviation malfunction (pulse signal)	- Wire harness or connector - Crankshaft position sensor - Camshaft position sensor - HV control ECU	Comes on	-	DTC stored	HV-91
P0343-601	Camshaft Position Sensor "A" Circuit High Input	GO signal circuit malfunction	- Wire harness or connector - HV control ECU	Comes on	-	DTC stored	HV-94
P0560-117	System Voltage	HV control ECU back-up power source circuit malfunction	- Wire harness or connector - HEV fuse	Comes on	Comes on	DTC stored	HV-97
P0630-804	VIN not Programmed or Mismatch-ECM / PCM	- VIN not stored in HV control ECU - Input VIN in HV control ECU not accurate	- HV control ECU	Comes on	Comes on	DTC stored	HV-101
P0705-571	Transmission Range Sensor Circuit	Open or GND short in shift main sensor circuit	- Wire harness or connector - Selector lever - HV control ECU	Comes on	-	DTC stored	HV-102
P0705-572	Transmission Range Sensor Circuit	+B short in shift main sensor circuit	- Wire harness or connector - Selector lever - HV control ECU	Comes on	-	DTC stored	HV-102
P0705-573	Transmission Range Sensor Circuit	Open or GND short in shift sub sensor circuit	- Wire harness or connector - Selector lever - HV control ECU	Comes on	-	DTC stored	HV-102
P0705-574	Transmission Range Sensor Circuit	+B short in shift sub sensor circuit	- Wire harness or connector - Selector lever - HV control ECU	Comes on	-	DTC stored	HV-102
P0705-575	Transmission Range Sensor Circuit	Open or GND short in select main sensor circuit	- Wire harness or connector - Selector lever - HV control ECU	Comes on	-	DTC stored	HV-102

HV

DTC No.	Detection Item	DTC Detection Condition	Trouble Area	Master Warning Light	MIL	Memory	See page
P0705-576	Transmission Range Sensor Circuit	+B short in select main sensor circuit	- Wire harness or connector - Selector lever - HV control ECU	Comes on	-	DTC stored	HV-102
P0705-577	Transmission Range Sensor Circuit	Open or GND short in select sub sensor circuit	- Wire harness or connector - Selector lever - HV control ECU	Comes on	-	DTC stored	HV-102
P0705-578	Transmission Range Sensor Circuit	+B short in select sub sensor circuit	- Wire harness or connector - Selector lever - HV control ECU	Comes on	-	DTC stored	HV-102
P0705-595	Transmission Range Sensor Circuit	Difference between shift main sensor value and shift sub sensor value is large	- Wire harness or connector - Selector lever - HV control ECU	Comes on	-	DTC stored	HV-102
P0705-596	Transmission Range Sensor Circuit	Difference between select main sensor value and select sub sensor value is large	- Wire harness or connector - Selector lever - HV control ECU	Comes on	-	DTC stored	HV-102
P0851-579	Park / Neutral Switch Input Circuit Low	GND short in P position switch circuit	- Wire harness or connector - P position switch - HV control ECU	Comes on	-	DTC stored	HV-112
P0852-580	Park / Neutral Switch Input Circuit High	Open or +B short in P position switch circuit	- Wire harness or connector - P position switch - HV control ECU	Comes on	-	DTC stored	HV-112

DTC No.	Detection Item	DTC Detection Condition	Trouble Area	Master Warning Light	MIL	Memory	See page
P0A08-264	DC / DC Converter Status Circuit	DC / DC converter malfunction	<ul style="list-style-type: none"> - Auxiliary battery - Fusible link block assembly - HV control ECU - Fuse (for 12 V electrical equipment) - Engine room relay block - Inverter cooling hose - Water pump with motor assembly - Cooling fan motor - No.2 cooling fan motor - Wire harness or connector - Inverter with converter assembly (DC / DC converter) 	Comes on	-	DTC stored	HV-115
P0A09-265	DC / DC Converter Status Circuit Low Input	Open or GND short in NODD signal circuit of DC / DC converter	<ul style="list-style-type: none"> - Wire harness or connector - Inverter with converter assembly 	Comes on	-	DTC stored	HV-124
P0A09-591	DC / DC Converter Status Circuit Low Input	Open or GND short in VLO signal circuit of DC / DC converter	<ul style="list-style-type: none"> - Wire harness or connector - Inverter with converter assembly 	Comes on	-	DTC stored	HV-127
P0A0D-350	High Voltage System Inter-Lock Circuit High	Operating safety devices with vehicle stopped (ILK signal is ON)	<ul style="list-style-type: none"> - Service plug grip installation - Inverter cover installation 	Comes on	-	DTC stored	HV-129
P0A0D-351	High Voltage System Inter-Lock Circuit High	Open in interlock signal circuit while vehicle is running	<ul style="list-style-type: none"> - Wire harness or connector - Battery plug (No. 2 interlock switch) - Inverter with converter assembly (No. 1 interlock switch) 	Comes on	-	DTC stored	HV-130
P0A0F-204	Engine Failed to Start	Abnormal signal input from ECM (abnormal engine output)	<ul style="list-style-type: none"> - ECM - SFI system 	Comes on	-	DTC stored	HV-134
P0A0F-205	Engine Failed to Start	Abnormal signal input from ECM (engine is unable to start)	<ul style="list-style-type: none"> - ECM - SFI system 	Comes on	-	DTC stored	HV-134

DTC No.	Detection Item	DTC Detection Condition	Trouble Area	Master Warning Light	MIL	Memory	See page
P0A0F-238	Engine Failed to Start	Engine does not start even though cranking it (transaxle input malfunction [engine system])	- Engine assembly - HV transaxle assembly (shaft or gear) - Transmission input damper - Wire harness or connector - HV control ECU	Comes on	-	DTC stored	HV-135
P0A0F-533	Engine Failed to Start	Abnormal signal input from ECM (abnormal engine output by running out of fuel)	- ECM - SFI system	Comes on	-	DTC stored	HV-134
P0A0F-534	Engine Failed to Start	Abnormal signal input from ECM (engine is unable to start by running out of fuel)	- ECM - SFI system	Comes on	-	DTC stored	HV-134
P0A10-263	DC / DC Converter Status Circuit High Input	+B short in NODD signal circuit of DC / DC converter	- Wire harness or connector - Inverter with converter assembly	Comes on	-	DTC stored	HV-124
P0A10-592	DC / DC Converter Status Circuit High Input	+B short in NODD signal circuit of DC / DC converter	- Wire harness or connector - Inverter with converter assembly	Comes on	-	DTC stored	HV-127
P0A1D-134	Hybrid Powertrain Control Module	HV control ECU internal error	- HV control ECU	Comes on	Comes on	DTC stored	HV-141
P0A1D-135	Hybrid Powertrain Control Module	HV control ECU internal error	- HV control ECU	Comes on	Comes on	DTC stored	HV-141
P0A1D-139	Hybrid Powertrain Control Module	HV control ECU internal error	- HV control ECU	Comes on	Comes on	DTC stored	HV-143
P0A1D-140	Hybrid Powertrain Control Module	HV control ECU internal error	- HV control ECU	Comes on	Comes on	DTC stored	HV-144
P0A1D-141	Hybrid Powertrain Control Module	HV control ECU internal error	- HV control ECU	Comes on	Comes on	DTC stored	HV-145
P0A1D-142	Hybrid Powertrain Control Module	ST signal of HV control ECU is ON with power switch OFF	- Wire harness or connector - Power source control ECU	Comes on	Comes on	DTC stored	HV-146
P0A1D-143	Hybrid Powertrain Control Module	HV control ECU internal error	- HV control ECU	Comes on	Comes on	DTC stored	HV-149
P0A1D-144	Hybrid Powertrain Control Module	HV control ECU internal error	- HV control ECU	Comes on	Comes on	DTC stored	HV-150
P0A1D-145	Hybrid Powertrain Control Module	HV control ECU internal error	- HV control ECU	Comes on	Comes on	DTC stored	HV-150

DTC No.	Detection Item	DTC Detection Condition	Trouble Area	Master Warning Light	MIL	Memory	See page
P0A1D-148	Hybrid Powertrain Control Module	HV control ECU internal error	- HV control ECU	Comes on	Comes on	DTC stored	HV-152
P0A1D-149	Hybrid Powertrain Control Module	HV control ECU internal error	- HV control ECU	Comes on	Comes on	DTC stored	HV-152
P0A1D-150	Hybrid Powertrain Control Module	HV control ECU internal error	- HV control ECU	Comes on	Comes on	DTC stored	HV-154
P0A1D-151	Hybrid Powertrain Control Module	HV control ECU internal error	- HV control ECU	Comes on	Comes on	DTC stored	HV-154
P0A1D-152	Hybrid Powertrain Control Module	HV control ECU internal error	- HV control ECU	Comes on	Comes on	DTC stored	HV-154
P0A1D-155	Hybrid Powertrain Control Module	HV control ECU internal error	- HV control ECU	Comes on	Comes on	DTC stored	HV-154
P0A1D-156	Hybrid Powertrain Control Module	HV control ECU internal error	- HV control ECU	Comes on	Comes on	DTC stored	HV-154
P0A1D-158	Hybrid Powertrain Control Module	HV control ECU internal error	- HV control ECU	Comes on	Comes on	DTC stored	HV-154
P0A1D-159	Hybrid Powertrain Control Module	HV control ECU internal error	- HV control ECU	Comes on	Comes on	DTC stored	HV-156
P0A1D-160	Hybrid Powertrain Control Module	HV control ECU internal error	- HV control ECU	Comes on	Comes on	DTC stored	HV-156
P0A1D-163	Hybrid Powertrain Control Module	HV control ECU internal error	- HV control ECU	Comes on	Comes on	DTC stored	HV-158
P0A1D-164	Hybrid Powertrain Control Module	HV control ECU internal error	- HV control ECU	Comes on	Comes on	DTC stored	HV-158
P0A1D-165	Hybrid Powertrain Control Module	HV control ECU internal error	- HV control ECU	Comes on	Comes on	DTC stored	HV-160
P0A1D-166	Hybrid Powertrain Control Module	HV control ECU internal error	- HV control ECU	Comes on	Comes on	DTC stored	HV-162
P0A1D-167	Hybrid Powertrain Control Module	HV control ECU internal error	- HV control ECU	Comes on	Comes on	DTC stored	HV-162
P0A1D-168	Hybrid Powertrain Control Module	HV control ECU internal error	- HV control ECU	Comes on	Comes on	DTC stored	HV-160
P0A1D-177	Hybrid Powertrain Control Module	HV control ECU internal error	- HV control ECU	Comes on	Comes on	DTC stored	HV-164
P0A1D-178	Hybrid Powertrain Control Module	HV control ECU internal error	- HV control ECU	Comes on	Comes on	DTC stored	HV-164
P0A1D-180	Hybrid Powertrain Control Module	HV control ECU internal error	- HV control ECU	Comes on	Comes on	DTC stored	HV-166
P0A1D-181	Hybrid Powertrain Control Module	HV control ECU internal error	- HV control ECU	Comes on	Comes on	DTC stored	HV-166

DTC No.	Detection Item	DTC Detection Condition	Trouble Area	Master Warning Light	MIL	Memory	See page
P0A1D-182	Hybrid Powertrain Control Module	HV control ECU internal error	- HV control ECU	Comes on	Comes on	DTC stored	HV-166
P0A1D-183	Hybrid Powertrain Control Module	HV control ECU internal error	- HV control ECU	Comes on	Comes on	DTC stored	HV-166
P0A1D-184	Hybrid Powertrain Control Module	HV control ECU internal error	- HV control ECU	Comes on	Comes on	DTC stored	HV-166
P0A1D-185	Hybrid Powertrain Control Module	HV control ECU internal error	- HV control ECU	Comes on	Comes on	DTC stored	HV-166
P0A1D-186	Hybrid Powertrain Control Module	HV control ECU internal error	- HV control ECU	Comes on	Comes on	DTC stored	HV-166
P0A1D-187	Hybrid Powertrain Control Module	HV control ECU internal error	- HV control ECU	Comes on	Comes on	DTC stored	HV-168
P0A1D-188	Hybrid Powertrain Control Module	HV control ECU internal error	- HV control ECU	Comes on	Comes on	DTC stored	HV-169
P0A1D-189	Hybrid Powertrain Control Module	HV control ECU internal error	- HV control ECU	Comes on	Comes on	DTC stored	HV-169
P0A1D-192	Hybrid Powertrain Control Module	HV control ECU internal error	- HV control ECU	Comes on	Comes on	DTC stored	HV-169
P0A1D-193	Hybrid Powertrain Control Module	HV control ECU internal error	- HV control ECU	Comes on	Comes on	DTC stored	HV-169
P0A1D-195	Hybrid Powertrain Control Module	HV control ECU internal error	- HV control ECU	Comes on	Comes on	DTC stored	HV-169
P0A1D-196	Hybrid Powertrain Control Module	HV control ECU internal error	- HV control ECU	Comes on	Comes on	DTC stored	HV-169
P0A1D-197	Hybrid Powertrain Control Module	HV control ECU internal error	- HV control ECU	Comes on	Comes on	DTC stored	HV-162
P0A1D-198	Hybrid Powertrain Control Module	HV control ECU internal error	- HV control ECU	Comes on	Comes on	DTC stored	HV-160
P0A1D-199	Hybrid Powertrain Control Module	HV control ECU internal error	- HV control ECU	Comes on	Comes on	DTC stored	HV-160
P0A1D-200	Hybrid Powertrain Control Module	HV control ECU internal error	- HV control ECU	Comes on	Comes on	DTC stored	HV-162
P0A1D-390	Hybrid Powertrain Control Module	Charge control malfunction	- HV control ECU	Comes on	Comes on	DTC stored	HV-171
P0A1D-392	Hybrid Powertrain Control Module	HV control ECU internal error	- HV control ECU	Comes on	Comes on	DTC stored	HV-164
P0A1D-393	Hybrid Powertrain Control Module	HV control ECU internal error	- HV control ECU	Comes on	Comes on	DTC stored	HV-172
P0A1D-511	Hybrid Powertrain Control Module	HV control ECU internal error	- HV control ECU	Comes on	Comes on	DTC stored	HV-158

DTC No.	Detection Item	DTC Detection Condition	Trouble Area	Master Warning Light	MIL	Memory	See page
P0A1D-512	Hybrid Powertrain Control Module	HV control ECU internal error	- HV control ECU	Comes on	Comes on	DTC stored	HV-158
P0A1D-564	Hybrid Powertrain Control Module	HV control ECU internal error	- HV control ECU	Comes on	Comes on	DTC stored	HV-154
P0A1D-565	Hybrid Powertrain Control Module	HV control ECU internal error	- HV control ECU	Comes on	Comes on	DTC stored	HV-169
P0A1D-567	Hybrid Powertrain Control Module	HV control ECU internal error	- HV control ECU	Comes on	Comes on	DTC stored	HV-164
P0A1D-568	Hybrid Powertrain Control Module	HV control ECU internal error	- HV control ECU	Comes on	Comes on	DTC stored	HV-173
P0A1D-569	Hybrid Powertrain Control Module	HV control ECU internal error	- HV control ECU	Comes on	Comes on	DTC stored	HV-173
P0A1D-570	Hybrid Powertrain Control Module	HV control ECU internal error	- HV control ECU	Comes on	Comes on	DTC stored	HV-141
P0A1D-615	Hybrid Powertrain Control Module	HV control ECU internal error	- HV control ECU	Comes on	Comes on	DTC stored	HV-175
P0A1F-123	Battery Energy Control Module	Abnormal signal input from battery ECU (ROM/RAM malfunction)	- HV battery system - Battery ECU	Comes on	Comes on	DTC stored	HV-177
P0A1F-129	Battery Energy Control Module	HV battery voltage circuit malfunction	- HV battery voltage circuit - Service plug grip - High voltage fuse - Battery plug - Battery ECU	Comes on	Comes on	DTC stored	HV-179
P0A1F-593	Battery Energy Control Module	IG2 signal circuit of battery ECU malfunction	- Wire harness or connector - Battery ECU	Comes on	Comes on	DTC stored	HV-183
P0A2B-248	Drive Motor "A" Temperature Sensor Circuit Range / Performance	No. 1 motor temperature sensor malfunction	- Hybrid vehicle motor	Comes on	-	DTC stored	HV-186
P0A2B-250	Drive Motor "A" Temperature Sensor Circuit Range / Performance	No. 1 motor temperature sensor performance problem	- Hybrid vehicle motor	Comes on	-	DTC stored	HV-186
P0A2C-247	Drive Motor "A" Temperature Sensor Circuit Low	GND short in No. 1 motor temperature sensor circuit	- Wire harness or connector - Hybrid vehicle motor - HV control ECU	Comes on	-	DTC stored	HV-187

DTC No.	Detection Item	DTC Detection Condition	Trouble Area	Master Warning Light	MIL	Memory	See page
P0A2D-249	Drive Motor "A" Temperature Sensor Circuit High	Open or +B short in No. 1 motor temperature sensor circuit	- Wire harness or connector - Hybrid vehicle motor - HV control ECU	Comes on	-	DTC stored	HV-187
P0A37-258	Generator Temperature Sensor Circuit Range / Performance	No. 2 motor temperature sensor malfunction	- Hybrid vehicle motor	Comes on	-	DTC stored	HV-193
P0A37-260	Generator Temperature Sensor Circuit Range / Performance	No. 2 motor temperature sensor performance problem	- Hybrid vehicle motor - Transaxle fluid leakage - HV transaxle assembly	Comes on	-	DTC stored	HV-194
P0A38-257	Generator Temperature Sensor Circuit Low	GND short in No. 2 motor temperature sensor circuit	- Wire harness or connector - Hybrid vehicle motor - HV control ECU	Comes on	-	DTC stored	HV-195
P0A39-259	Generator Temperature Sensor Circuit High	Open or +B short in No. 2 motor temperature sensor circuit	- Wire harness or connector - Hybrid vehicle motor - HV control ECU	Comes on	-	DTC stored	HV-195
P0A3F-243	Drive Motor "A" Position Sensor Circuit	Interphase short in motor resolver circuit	- Wire harness or connector - Hybrid vehicle motor - HV control ECU	Comes on	Comes on	DTC stored	HV-200
P0A40-500	Drive Motor "A" Position Sensor Circuit Range / Performance	Motor resolver output is out of normal range	- Wire harness or connector - Hybrid vehicle motor - HV control ECU	Comes on	Comes on	DTC stored	HV-200
P0A41-245	Drive Motor "A" Position Sensor Circuit Low	Open or short in motor resolver circuit	- Wire harness or connector - Hybrid vehicle motor - HV control ECU	Comes on	Comes on	DTC stored	HV-200
P0A4B-253	Generator Position Sensor Circuit	Interphase short in generator resolver circuit	- Wire harness or connector - Hybrid vehicle generator - HV control ECU	Comes on	Comes on	DTC stored	HV-205
P0A4C-513	Generator Position Sensor Circuit Range / Performance	Generator resolver output is out of normal range	- Wire harness or connector - Hybrid vehicle generator - HV control ECU	Comes on	Comes on	DTC stored	HV-205

DTC No.	Detection Item	DTC Detection Condition	Trouble Area	Master Warning Light	MIL	Memory	See page
P0A4D-255	Generator Position Sensor Circuit Low	Open or short in generator resolver circuit	- Wire harness or connector - Hybrid vehicle generator - HV control ECU	Comes on	Comes on	DTC stored	HV-205
P0A51-174	Drive Motor "A" Current Sensor Circuit	HV control ECU internal error	- HV control ECU	Comes on	-	DTC stored	HV-209
P0A60-288	Drive Motor "A" Phase V Current	Phase V current sub sensor of motor inverter current sensor malfunction	- Wire harness or connector - Inverter with converter assembly	Comes on	Comes on	DTC stored	HV-210
P0A60-289	Drive Motor "A" Phase V Current	Open in phase V current sub sensor circuit of motor inverter current sensor	- Wire harness or connector - Inverter with converter assembly	Comes on	Comes on	DTC stored	HV-210
P0A60-290	Drive Motor "A" Phase V Current	Phase V current main sensor of motor inverter current sensor malfunction	- Wire harness or connector - Inverter with converter assembly	Comes on	Comes on	DTC stored	HV-210
P0A60-292	Drive Motor "A" Phase V Current	Open in phase V current main sensor circuit of motor inverter current sensor	- Wire harness or connector - Inverter with converter assembly	Comes on	Comes on	DTC stored	HV-210
P0A60-294	Drive Motor "A" Phase V Current	Phase V current main and sub sensors of motor inverter current sensor performance problem	- Wire harness or connector - Inverter with converter assembly	Comes on	Comes on	DTC stored	HV-210
P0A60-501	Drive Motor "A" Phase V Current	Phase V current main and sub sensors of motor inverter current sensor offset malfunction	- Wire harness or connector - Inverter with converter assembly	Comes on	Comes on	DTC stored	HV-210
P0A63-296	Drive Motor "A" Phase W Current	Phase W current sub sensor of motor inverter current sensor malfunction	- Wire harness or connector - Inverter with converter assembly	Comes on	Comes on	DTC stored	HV-210
P0A63-297	Drive Motor "A" Phase W Current	Open in phase W current sub sensor circuit of motor inverter current sensor	- Wire harness or connector - Inverter with converter assembly	Comes on	Comes on	DTC stored	HV-210
P0A63-298	Drive Motor "A" Phase W Current	Phase W current main sensor of motor inverter current sensor malfunction	- Wire harness or connector - Inverter with converter assembly	Comes on	Comes on	DTC stored	HV-210

DTC No.	Detection Item	DTC Detection Condition	Trouble Area	Master Warning Light	MIL	Memory	See page
P0A63-300	Drive Motor "A" Phase W Current	Open in phase W current main sensor circuit of motor inverter current sensor	- Wire harness or connector - Inverter with converter assembly	Comes on	Comes on	DTC stored	HV-210
P0A63-302	Drive Motor "A" Phase W Current	Phase W current main and sub sensors of motor inverter current sensor performance problem	- Wire harness or connector - Inverter with converter assembly	Comes on	Comes on	DTC stored	HV-210
P0A63-502	Drive Motor "A" Phase W Current	Phase W current main and sub sensors of motor inverter current sensor offset malfunction	- Wire harness or connector - Inverter with converter assembly	Comes on	Comes on	DTC stored	HV-210
P0A72-326	Generator Phase V Current	Phase V current sub sensor of generator inverter current sensor malfunction	- Wire harness or connector - Inverter with converter assembly	Comes on	Comes on	DTC stored	HV-215
P0A72-327	Generator Phase V Current	Open in phase V current sub sensor circuit of generator inverter current sensor	- Wire harness or connector - Inverter with converter assembly	Comes on	Comes on	DTC stored	HV-215
P0A72-328	Generator Phase V Current	Phase V current main sensor of generator inverter current sensor malfunction	- Wire harness or connector - Inverter with converter assembly	Comes on	Comes on	DTC stored	HV-215
P0A72-330	Generator Phase V Current	Open in phase V current main sensor circuit of generator inverter current sensor	- Wire harness or connector - Inverter with converter assembly	Comes on	Comes on	DTC stored	HV-215
P0A72-333	Generator Phase V Current	Phase V current main and sub sensors of generator inverter current sensor performance problem	- Wire harness or connector - Inverter with converter assembly	Comes on	Comes on	DTC stored	HV-215
P0A72-515	Generator Phase V Current	Phase V current main and sub sensors of generator inverter current sensor offset malfunction	- Wire harness or connector - Inverter with converter assembly	Comes on	Comes on	DTC stored	HV-215

DTC No.	Detection Item	DTC Detection Condition	Trouble Area	Master Warning Light	MIL	Memory	See page
P0A75-334	Generator Phase W Current	Phase W current sub sensor of generator inverter current sensor malfunction	- Wire harness or connector - Inverter with converter assembly	Comes on	Comes on	DTC stored	HV-215
P0A75-335	Generator Phase W Current	Open in phase W current sub sensor circuit of generator inverter current sensor	- Wire harness or connector - Inverter with converter assembly	Comes on	Comes on	DTC stored	HV-215
P0A75-336	Generator Phase W Current	Phase W current main sensor of generator inverter current sensor malfunction	- Wire harness or connector - Inverter with converter assembly	Comes on	Comes on	DTC stored	HV-215
P0A75-338	Generator Phase W Current	Open in phase W current main sensor circuit of generator inverter current sensor	- Wire harness or connector - Inverter with converter assembly	Comes on	Comes on	DTC stored	HV-215
P0A75-341	Generator Phase W Current	Phase W current main and sub sensors of generator inverter current sensor performance problem	- Wire harness or connector - Inverter with converter assembly	Comes on	Comes on	DTC stored	HV-215
P0A75-516	Generator Phase W Current	Phase W current main and sub sensors of generator inverter current sensor offset malfunction	- Wire harness or connector - Inverter with converter assembly	Comes on	Comes on	DTC stored	HV-215
P0A78-266	Drive Motor "A" Inverter Performance	Open or GND short in inverter voltage (VH) signal circuit	- Wire harness or connector - Inverter with converter assembly - HV control ECU	Comes on	Comes on	DTC stored	HV-220
P0A78-267	Drive Motor "A" Inverter Performance	+B short in inverter voltage (VH) signal circuit	- Wire harness or connector - Inverter with converter assembly - HV control ECU	Comes on	Comes on	DTC stored	HV-220
P0A78-272	Drive Motor "A" Inverter Performance	Abnormality in motor PWM circuit	- Wire harness or connector - Inverter with converter assembly	Comes on	Comes on	DTC stored	HV-228

DTC No.	Detection Item	DTC Detection Condition	Trouble Area	Master Warning Light	MIL	Memory	See page
P0A78-278	Drive Motor "A" Inverter Performance	+B short in motor inverter over-voltage (OVH) signal circuit	- Wire harness or connector - Inverter with converter assembly	Comes on	Comes on	DTC stored	HV-231
P0A78-279	Drive Motor "A" Inverter Performance	Motor inverter over-voltage (OVH) signal detection (over-voltage by inverter assembly malfunction)	- Wire harness or connector - HV transaxle assembly - Hybrid vehicle motor - Hybrid vehicle generator - HV control ECU - Inverter with converter assembly	Comes on	Comes on	DTC stored	HV-234
P0A78-280	Drive Motor "A" Inverter Performance	Open or GND short in motor inverter over-voltage (OVH) signal circuit	- Wire harness or connector - Inverter with converter assembly	Comes on	Comes on	DTC stored	HV-231
P0A78-282	Drive Motor "A" Inverter Performance	Motor inverter over voltage (OVH) signal detection (circuit malfunction)	- Wire harness or connector - Inverter with converter assembly	Comes on	Comes on	DTC stored	HV-243
P0A78-283	Drive Motor "A" Inverter Performance	+B short in motor inverter fail (MFIV) signal circuit	- Wire harness or connector - Inverter with converter assembly	Comes on	Comes on	DTC stored	HV-247
P0A78-284	Drive Motor "A" Inverter Performance	Motor inverter fail (MFIV) signal detection (inverter overheating)	- Wire harness or connector - Inverter cooling system - Water pump with motor assembly - Cooling fan motor - No. 2 cooling fan motor - HV transaxle assembly - Hybrid vehicle motor - HV control ECU - Inverter with converter assembly	Comes on	Comes on	DTC stored	HV-250
P0A78-285	Drive Motor "A" Inverter Performance	Open or GND short in motor inverter fail (MFIV) signal circuit	- Wire harness or connector - Inverter with converter assembly	Comes on	Comes on	DTC stored	HV-247
P0A78-286	Drive Motor "A" Inverter Performance	Motor inverter fail (MFIV) signal detection (circuit malfunction)	- Wire harness or connector - Inverter with converter assembly	Comes on	Comes on	DTC stored	HV-258

DTC No.	Detection Item	DTC Detection Condition	Trouble Area	Master Warning Light	MIL	Memory	See page
P0A78-287	Drive Motor "A" Inverter Performance	Motor inverter fail (MFIV) signal detection (over current by inverter assembly malfunction)	- Wire harness or connector - HV transaxle assembly - Hybrid vehicle motor - HV control ECU - Inverter with converter assembly	Comes on	Comes on	DTC stored	HV-261
P0A78-304	Drive Motor "A" Inverter Performance	Open or +B short in motor gate shutdown (MSDN) signal circuit	- Wire harness or connector - Inverter with converter assembly	Comes on	Comes on	DTC stored	HV-268
P0A78-305	Drive Motor "A" Inverter Performance	GND short in motor gate shutdown (MSDN) signal circuit	- Wire harness or connector - Inverter with converter assembly	Comes on	Comes on	DTC stored	HV-268
P0A78-306	Drive Motor "A" Inverter Performance	Failure in monitoring MG2 torque performance	- Wire harness or connector - Inverter with converter assembly	Comes on	Comes on	DTC stored	HV-271
P0A78-308	Drive Motor "A" Inverter Performance	Collision signal input from center airbag sensor or No. 1 circuit breaker sensor	- Supplemental restraint system - No. 1 circuit breaker sensor	Comes on	Comes on	DTC stored	HV-274
P0A78-503	Drive Motor "A" Inverter Performance	Motor inverter over-voltage (OVH) signal detection (over-voltage by HV control ECU malfunction)	- Wire harness or connector - HV transaxle assembly - Hybrid vehicle motor - Hybrid vehicle generator - HV control ECU - Inverter with converter assembly	Comes on	Comes on	DTC stored	HV-234
P0A78-504	Drive Motor "A" Inverter Performance	Motor inverter over-voltage (OVH) signal detection (over-voltage by HV transaxle assembly malfunction)	- Wire harness or connector - HV transaxle assembly - Hybrid vehicle motor - Hybrid vehicle generator - HV control ECU - Inverter with converter assembly	Comes on	Comes on	DTC stored	HV-234

DTC No.	Detection Item	DTC Detection Condition	Trouble Area	Master Warning Light	MIL	Memory	See page
P0A78-505	Drive Motor "A" Inverter Performance	Motor inverter fail (MFIV) signal detection (over current by HV control ECU malfunction)	- Wire harness or connector - HV transaxle assembly - Hybrid vehicle motor - Hybrid vehicle generator - HV control ECU - Inverter with converter assembly	Comes on	Comes on	DTC stored	HV-261
P0A78-506	Drive Motor "A" Inverter Performance	Motor inverter fail (MFIV) signal detection (over current by HV transaxle assembly malfunction)	- Wire harness or connector - HV transaxle assembly - Hybrid vehicle motor - Hybrid vehicle generator - HV control ECU - Inverter with converter assembly	Comes on	Comes on	DTC stored	HV-261
P0A78-507	Drive Motor "A" Inverter Performance	Open in motor gate shutdown (MSDN) signal circuit	- Wire harness or connector - Inverter with converter assembly	Comes on	Comes on	DTC stored	HV-268
P0A78-508	Drive Motor "A" Inverter Performance	Motor gate shutdown (MSDN) signal malfunction	- Wire harness or connector - HV control ECU	Comes on	Comes on	DTC stored	HV-275
P0A78-510	Drive Motor "A" Inverter Performance	Motor inverter gate malfunction	- Wire harness or connector - Inverter with converter assembly	Comes on	Comes on	DTC stored	HV-278
P0A78-523	Drive Motor "A" Inverter Performance	Inverter voltage (VH) sensor offset malfunction	- System main relay - Inverter with converter assembly	Comes on	Comes on	DTC stored	HV-280
P0A78-586	Drive Motor "A" Inverter Performance	Inverter voltage (VH) sensor performance problem	- Wire harness or connector - Inverter with converter assembly	Comes on	Comes on	DTC stored	HV-282
P0A7A-309	Generator Inverter Performance	Abnormality in generator PWM circuit	- Wire harness or connector - Inverter with converter assembly	Comes on	Comes on	DTC stored	HV-285
P0A7A-321	Generator Inverter Performance	+B short in generator inverter fail (GFIV) signal circuit	- Wire harness or connector - Inverter with converter assembly	Comes on	Comes on	DTC stored	HV-288

DTC No.	Detection Item	DTC Detection Condition	Trouble Area	Master Warning Light	MIL	Memory	See page
P0A7A-322	Generator Inverter Performance	Generator inverter fail (GFIV) signal detection (inverter overheating)	- Wire harness or connector - Inverter cooling system - Water pump with motor assembly - Cooling fan motor - No. 2 cooling fan motor - HV transaxle assembly - Hybrid vehicle generator - HV control ECU - Inverter with converter assembly	Comes on	Comes on	DTC stored	HV-291
P0A7A-323	Generator Inverter Performance	Open or GND short in generator inverter fail (GFIV) signal circuit	- Wire harness or connector - Inverter with converter assembly	Comes on	Comes on	DTC stored	HV-288
P0A7A-324	Generator Inverter Performance	Generator inverter fail (GFIV) signal detection (circuit malfunction)	- Wire harness or connector - Inverter with converter assembly	Comes on	Comes on	DTC stored	HV-299
P0A7A-325	Generator Inverter Performance	Generator inverter fail (GFIV) signal detection (over current by inverter assembly malfunction)	- Wire harness or connector - HV transaxle assembly - Hybrid vehicle generator - HV control ECU - Inverter with converter assembly	Comes on	Comes on	DTC stored	HV-302
P0A7A-342	Generator Inverter Performance	Open or +B short in generator gate shutdown (GSDN) signal circuit	- Wire harness or connector - Inverter with converter assembly	Comes on	Comes on	DTC stored	HV-309
P0A7A-343	Generator Inverter Performance	GND short in generator gate shutdown (GSDN) signal circuit	- Wire harness or connector - Inverter with converter assembly	Comes on	Comes on	DTC stored	HV-309
P0A7A-344	Generator Inverter Performance	Failure in monitoring MG1 torque performance	- Hybrid vehicle generator - Inverter with converter assembly	Comes on	Comes on	DTC stored	HV-312

DTC No.	Detection Item	DTC Detection Condition	Trouble Area	Master Warning Light	MIL	Memory	See page
P0A7A-517	Generator Inverter Performance	Generator inverter fail (GFIV) signal detection (over current by HV control ECU malfunction)	- Wire harness or connector - HV transaxle assembly - Hybrid vehicle generator - HV control ECU - Inverter with converter assembly	Comes on	Comes on	DTC stored	HV-302
P0A7A-518	Generator Inverter Performance	Generator inverter fail (GFIV) signal detection (over current by HV transaxle assembly malfunction)	- Wire harness or connector - HV transaxle assembly - Hybrid vehicle generator - HV control ECU - Inverter with converter assembly	Comes on	Comes on	DTC stored	HV-302
P0A7A-519	Generator Inverter Performance	Open in generator gate shutdown (GSDN) signal circuit	- Wire harness or connector - Inverter with converter assembly	Comes on	Comes on	DTC stored	HV-309
P0A7A-520	Generator Inverter Performance	Generator gate shutdown (GSDN) signal malfunction	- Wire harness or connector - HV control ECU	Comes on	Comes on	DTC stored	HV-315
P0A7A-522	Generator Inverter Performance	Generator inverter gate malfunction	- Wire harness or connector - Inverter with converter assembly	Comes on	Comes on	DTC stored	HV-318
P0A90-239	Drive Motor "A" Performance	HV transaxle input malfunction (shaft damaged)	- Engine assembly - HV transaxle assembly (shaft or gear) - Transmission input damper - Wire harness or connector - HV control ECU	Comes on	Comes on	DTC stored	HV-321
P0A90-240	Drive Motor "A" Performance	Generator locked	- Hybrid vehicle generator	Comes on	Comes on	DTC stored	HV-328
P0A90-241	Drive Motor "A" Performance	HV transaxle input malfunction (torque limiter slipping)	- Engine assembly - HV transaxle assembly (shaft or gear) - Transmission input damper - Wire harness or connector - HV control ECU	Comes on	Comes on	DTC stored	HV-321
P0A90-242	Drive Motor "A" Performance	Planetary gear locked	- HV transaxle assembly	Comes on	Comes on	DTC stored	HV-329

DTC No.	Detection Item	DTC Detection Condition	Trouble Area	Master Warning Light	MIL	Memory	See page
P0A90-251	Drive Motor "A" Performance	MG2 magnetic force deterioration or same phase short circuit	- Hybrid vehicle motor	Comes on	Comes on	DTC stored	HV-330
P0A90-509	Drive Motor "A" Performance	MG2 system malfunction	- Hybrid vehicle motor - Inverter with converter assembly	Comes on	Comes on	DTC stored	HV-332
P0A90-602	Drive Motor "A" Performance	HV transaxle output malfunction	- Engine assembly - HV transaxle assembly (shaft or gear) - Transmission input damper - Wire harness or connector - HV control ECU	Comes on	Comes on	DTC stored	HV-321
P0A90-604	Drive Motor "A" Performance	MG2 power balance malfunction (small power balance)	- Battery current sensor - Hybrid vehicle motor	Comes on	Comes on	DTC stored	HV-335
P0A90-605	Drive Motor "A" Performance	MG2 power balance malfunction (large power balance)	- Battery current sensor - Hybrid vehicle motor	Comes on	Comes on	DTC stored	HV-335
P0A92-261	Hybrid Generator Performance	MG1 magnetic force deterioration or same phase short circuit	- Hybrid vehicle generator	Comes on	Comes on	DTC stored	HV-338
P0A92-521	Hybrid Generator Performance	MG1 system malfunction	- Hybrid vehicle generator - Inverter with converter assembly	Comes on	Comes on	DTC stored	HV-340
P0A92-606	Hybrid Generator Performance	MG1 power balance malfunction (small power balance)	- Battery current sensor - Hybrid vehicle generator	Comes on	Comes on	DTC stored	HV-343
P0A92-607	Hybrid Generator Performance	MG1 power balance malfunction (large power balance)	- Battery current sensor - Hybrid vehicle generator	Comes on	Comes on	DTC stored	HV-343

DTC No.	Detection Item	DTC Detection Condition	Trouble Area	Master Warning Light	MIL	Memory	See page
P0A93-346	Inverter Cooling System Performance	Inverter cooling system malfunction (water pump system malfunction)	- Wire harness or connector - Inverter cooling system - Water pump with motor assembly - Cooling fan motor - No. 2 cooling fan motor - Inverter with converter assembly	Comes on	Comes on	DTC stored	HV-346
P0A93-347	Inverter Cooling System Performance	Inverter cooling system malfunction (electric cooling fan system malfunction)	- Wire harness or connector - Inverter cooling system - Water pump with motor assembly - Cooling fan motor - No. 2 cooling fan motor - Inverter with converter assembly	Comes on	Comes on	DTC stored	HV-346
P0A94-442	DC / DC Converter Performance	Abnormal voltage execution value	- Inverter with converter assembly	Comes on	Comes on	DTC stored	HV-350
P0A94-545	DC / DC Converter Performance	Open or GND short in boost converter over-voltage (OVL) signal circuit	- Wire harness or connector - Inverter with converter assembly	Comes on	Comes on	DTC stored	HV-352
P0A94-546	DC / DC Converter Performance	+B short in boost converter over-voltage (OVL) signal circuit	- Wire harness or connector - Inverter with converter assembly	Comes on	Comes on	DTC stored	HV-352
P0A94-547	DC / DC Converter Performance	Boost converter over voltage (OVL) signal detection (over voltage by HV control ECU malfunction)	- Wire harness or connector - HV transaxle assembly - Hybrid vehicle motor - Hybrid vehicle generator - HV control ECU - Inverter with converter assembly	Comes on	Comes on	DTC stored	HV-355

DTC No.	Detection Item	DTC Detection Condition	Trouble Area	Master Warning Light	MIL	Memory	See page
P0A94-548	DC / DC Converter Performance	Boost converter over voltage (OVL) signal detection (over voltage by inverter assembly malfunction)	- Wire harness or connector - HV transaxle assembly - Hybrid vehicle motor - Hybrid vehicle generator - HV control ECU - Inverter with converter assembly	Comes on	Comes on	DTC stored	HV-355
P0A94-549	DC / DC Converter Performance	Boost converter over voltage (OVL) signal detection (over voltage by HV transaxle assembly malfunction)	- Wire harness or connector - HV transaxle assembly - Hybrid vehicle motor - Hybrid vehicle generator - HV control ECU - Inverter with converter assembly	Comes on	Comes on	DTC stored	HV-355
P0A94-550	DC / DC Converter Performance	Boost converter over-voltage (OVL) signal detection (circuit malfunction)	- Wire harness or connector - Inverter with converter assembly	Comes on	Comes on	DTC stored	HV-363
P0A94-551	DC / DC Converter Performance	Open or GND short in boost converter fail (FCV) signal circuit	- Wire harness or connector - Inverter with converter assembly	Comes on	Comes on	DTC stored	HV-366
P0A94-552	DC / DC Converter Performance	+B short in boost converter fail (FCV) signal circuit	- Wire harness or connector - Inverter with converter assembly	Comes on	Comes on	DTC stored	HV-366
P0A94-553	DC / DC Converter Performance	Boost converter fail (FCV) signal detection (boost converter overheating)	- Wire harness or connector - Inverter cooling system - Water pump with motor assembly - Cooling fan motor - No. 2 cooling fan motor - HV transaxle assembly - Hybrid vehicle motor - Hybrid vehicle generator - HV control ECU - Inverter with converter assembly	Comes on	Comes on	DTC stored	HV-369

HV

DTC No.	Detection Item	DTC Detection Condition	Trouble Area	Master Warning Light	MIL	Memory	See page
P0A94-554	DC / DC Converter Performance	Boost converter fail (FCV) signal detection (over current by HV control ECU malfunction)	- Wire harness or connector - HV transaxle assembly - Hybrid vehicle motor - Hybrid vehicle generator - HV control ECU - Inverter with converter assembly	Comes on	Comes on	DTC stored	HV-378
P0A94-555	DC / DC Converter Performance	Boost converter fail (FCV) signal detection (over current by inverter assembly malfunction)	- Wire harness or connector - HV transaxle assembly - Hybrid vehicle motor - Hybrid vehicle generator - HV control ECU - Inverter with converter assembly	Comes on	Comes on	DTC stored	HV-378
P0A94-556	DC / DC Converter Performance	Boost converter fail (FCV) signal detection (over current by HV transaxle assembly malfunction)	- Wire harness or connector - HV transaxle assembly - Hybrid vehicle motor - Hybrid vehicle generator - HV control ECU - Inverter with converter assembly	Comes on	Comes on	DTC stored	HV-378
P0A94-557	DC / DC Converter Performance	Boost converter fail (FCV) signal detection (circuit malfunction)	- Wire harness or connector - Inverter with converter assembly	Comes on	Comes on	DTC stored	HV-386
P0A94-558	DC / DC Converter Performance	GND short in boost converter gate shutdown (CSDN) signal circuit	- Wire harness or connector - Inverter with converter assembly	Comes on	Comes on	DTC stored	HV-389
P0A94-559	DC / DC Converter Performance	Open or +B short in boost converter gate shutdown (CSDN) signal circuit	- Wire harness or connector - Inverter with converter assembly	Comes on	Comes on	DTC stored	HV-389
P0A94-560	DC / DC Converter Performance	Open in boost converter gate shutdown (CSDN) signal circuit	- Wire harness or connector - Inverter with converter assembly	Comes on	Comes on	DTC stored	HV-389
P0A94-561	DC / DC Converter Performance	Abnormal boost converter gate shutdown (CSDN) signal	- Wire harness or connector - HV control ECU	Comes on	Comes on	DTC stored	HV-392

DTC No.	Detection Item	DTC Detection Condition	Trouble Area	Master Warning Light	MIL	Memory	See page
P0A94-583	DC / DC Converter Performance	Open or GND short in boost converter temperature sensor circuit	- Wire harness or connector - Inverter with converter assembly - HV control ECU	Comes on	Comes on	DTC stored	HV-395
P0A94-584	DC / DC Converter Performance	+B short in boost converter temperature sensor circuit	- Wire harness or connector - Inverter with converter assembly - HV control ECU	Comes on	Comes on	DTC stored	HV-395
P0A94-585	DC / DC Converter Performance	Boost converter voltage (VL) sensor performance problem	- Wire harness or connector - Inverter with converter assembly	Comes on	Comes on	DTC stored	HV-401
P0A94-587	DC / DC Converter Performance	Difference between voltages from HV battery voltage (VB) sensor and boost converter voltage (VL) sensor is large	- Wire harness or connector - Inverter with converter assembly - Service plug grip - High voltage fuse - Battery ECU	Comes on	Comes on	DTC stored	HV-404
P0A94-588	DC / DC Converter Performance	Abnormality in boost converter PWM circuit	- Wire harness or connector - Inverter with converter assembly	Comes on	Comes on	DTC stored	HV-409
P0A94-589	DC / DC Converter Performance	Open or GND short in boost converter voltage (VL) signal circuit	- Wire harness or connector - Inverter with converter assembly - HV control ECU	Comes on	Comes on	DTC stored	HV-412
P0A94-590	DC / DC Converter Performance	+B short in boost converter voltage (VL) signal circuit	- Wire harness or connector - Inverter with converter assembly - HV control ECU	Comes on	Comes on	DTC stored	HV-412
P0AA1-231	Hybrid Battery Positive Contactor Circuit Stuck Closed	System main relay terminal of HV battery positive side stuck closed	- No. 1 system main relay - No. 2 system main relay	Comes on	-	DTC stored	HV-418
P0AA1-233	Hybrid Battery Positive Contactor Circuit Stuck Closed	System main relay terminals of HV battery positive and negative sides stuck closed	- No. 1 system main relay - No. 2 system main relay - No. 3 system main relay	Comes on	-	DTC stored	HV-419
P0AA4-232	Hybrid Battery Negative Contactor Circuit Stuck Closed	System main relay terminal of HV battery negative side stuck closed	- No. 3 system main relay	Comes on	Comes on	DTC stored	HV-420

DTC No.	Detection Item	DTC Detection Condition	Trouble Area	Master Warning Light	MIL	Memory	See page
P0AA6-526	Hybrid Battery Voltage System Isolation Fault	Insulation resistance of high voltage circuit and body is low	<ul style="list-style-type: none"> - Frame wire - System main relay - System main resistor - HV battery assembly - Electric inverter compressor - Battery ECU - HV transaxle assembly - Inverter with converter assembly - Main battery cable - No. 2 main battery cable - Battery plug - No. 2 frame wire - Junction block 	Comes on	-	DTC stored	HV-421
P0AA6-611	Hybrid Battery Voltage System Isolation Fault	Insulation resistance of A/C compressor motor or A/C inverter is low	<ul style="list-style-type: none"> - Electric inverter compressor - Inverter with converter assembly 	Comes on	-	DTC stored	HV-421
P0AA6-612	Hybrid Battery Voltage System Isolation Fault	Insulation resistance of HV battery, battery ECU, system main relay, or system main resistor is low	<ul style="list-style-type: none"> - HV battery assembly - Battery ECU - System main relay - System main resistor - Main battery cable - No. 2 main battery cable - Battery plug - No. 2 frame wire - Junction block 	Comes on	-	DTC stored	HV-421
P0AA6-613	Hybrid Battery Voltage System Isolation Fault	Insulation resistance of HV transaxle or motor and generator inverters is low	<ul style="list-style-type: none"> - HV transaxle assembly - Inverter with converter assembly 	Comes on	-	DTC stored	HV-421

HV

DTC No.	Detection Item	DTC Detection Condition	Trouble Area	Master Warning Light	MIL	Memory	See page
P0AA6-614	Hybrid Battery Voltage System Isolation Fault	Insulation resistance of motor and generator inverters, A/C inverter, system main relay, system main resistor, or frame wire is low	- Frame wire - System main relay - System main resistor - HV battery assembly - Inverter with converter assembly - Main battery cable - No. 2 main battery cable - Battery plug - No. 2 frame wire - Junction block	Comes on	-	DTC stored	HV-421
P0ADB-227	Hybrid Battery Positive Contactor Control Circuit Low	GND short in No. 2 system main relay circuit	- Wire harness or connector - No. 2 system main relay - HV control ECU	Comes on	-	DTC stored	HV-439
P0ADC-226	Hybrid Battery Positive Contactor Control Circuit High	Open or +B short in No. 2 system main relay circuit	- Wire harness or connector - No. 2 system main relay - HV control ECU	Comes on	-	DTC stored	HV-439
P0ADF-229	Hybrid Battery Negative Contactor Control Circuit Low	GND short in No. 3 system main relay circuit	- Wire harness or connector - No. 3 system main relay - HV control ECU	Comes on	-	DTC stored	HV-441
P0AE0-228	Hybrid Battery Negative Contactor Control Circuit High	Open or +B short in No. 3 system main relay circuit	- Wire harness or connector - No. 3 system main relay - HV control ECU	Comes on	Comes on	DTC stored	HV-441
P0AE6-225	Hybrid Battery Precharge Contactor Control Circuit Low	GND short in No. 1 system main relay circuit	- Wire harness or connector - No. 1 system main relay - HV control ECU	Comes on	-	DTC stored	HV-444
P0AE7-224	Hybrid Battery Precharge Contactor Control Circuit High	Open or +B short in No. 1 system main relay circuit	- Wire harness or connector - No. 1 system main relay - HV control ECU	Comes on	-	DTC stored	HV-444

DTC No.	Detection Item	DTC Detection Condition	Trouble Area	Master Warning Light	MIL	Memory	See page
P0AEE-276	Motor Inverter Temperature Sensor "A" Circuit Range / Performance	Sudden change in motor inverter temperature sensor output	- Wire harness or connector - Inverter cooling system - Water pump w/ motor and bracket assembly - Cooling fan motor - No. 2 Cooling fan motor - w/ Converter inverter assembly	Comes on	-	DTC stored	HV-448
P0AEE-277	Motor Inverter Temperature Sensor "A" Circuit Range / Performance	Motor inverter temperature sensor output deviation	- Wire harness or connector - Inverter cooling system - Water pump w/ motor and bracket assembly - Cooling fan motor - No. 2 Cooling fan motor - w/ Converter inverter assembly	Comes on	-	DTC stored	HV-448
P0AEF-275	Drive Motor Inverter Temperature Sensor "A" Circuit Low	Open or GND short in motor inverter temperature sensor circuit	- Wire harness or connector - w/ Converter inverter assembly - HV control ECU	Comes on	-	DTC stored	HV-453
P0AF0-274	Drive Motor Inverter Temperature Sensor "A" Circuit High	+B short in monitor inverter temperature sensor circuit	- Wire harness or connector - w/ Converter inverter assembly - HV control ECU	Comes on	-	DTC stored	HV-453
P2120-111	Throttle / Pedal Position Sensor / Switch "D" Circuit	Accelerator pedal position main sensor value does not change while its sub sensor value changes	- Accelerator pedal rod	Comes on	-	DTC stored	HV-458
P2121-106	Throttle / Pedal Position Sensor / Switch "D" Circuit Range / Performance	Internal error of accelerator pedal position main sensor	- Accelerator pedal rod	Comes on	-	DTC stored	HV-458
P2121-114	Throttle / Pedal Position Sensor / Switch "D" Circuit Range / Performance	Accelerator pedal not smoothly returning to its original position	- Accelerator pedal rod	Comes on	-	DTC stored	HV-458

DTC No.	Detection Item	DTC Detection Condition	Trouble Area	Master Warning Light	MIL	Memory	See page
P2122-104	Throttle / Pedal Position Sensor / Switch "D" Circuit Low Input	Open or GND short in accelerator pedal position main sensor circuit	- Wire harness or connector - Accelerator pedal rod - HV control ECU	Comes on	-	DTC stored	HV-460
P2123-105	Throttle / Pedal Position Sensor / Switch "D" Circuit High Input	+B short in accelerator pedal position main sensor circuit	- Wire harness or connector - Accelerator pedal rod - HV control ECU	Comes on	-	DTC stored	HV-460
P2125-112	Throttle / Pedal Position Sensor / Switch "E" Circuit	Accelerator pedal position sub sensor value does not change while its main sensor value changes	- Accelerator pedal rod	Comes on	-	DTC stored	HV-458
P2126-109	Throttle / Pedal Position Sensor / Switch "E" Circuit Range / Performance	Internal error of accelerator pedal position sub sensor	- Accelerator pedal rod	Comes on	-	DTC stored	HV-458
P2127-107	Throttle / Pedal Position Sensor / Switch "E" Circuit Low Input	Open or GND short in accelerator pedal position sub sensor circuit	- Wire harness or connector - Accelerator pedal rod - HV control ECU	Comes on	-	DTC stored	HV-460
P2128-108	Throttle / Pedal Position Sensor / Switch "E" Circuit High Input	+B short in accelerator pedal position sub sensor circuit	- Wire harness or connector - Accelerator pedal rod - HV control ECU	Comes on	-	DTC stored	HV-460
P2138-110	Throttle / Pedal Position Sensor / Switch "D" / "E" Voltage Correlation	Difference between main sensor value and sub sensor value is large	- Accelerator pedal rod	Comes on	-	DTC stored	HV-458
P3000-123	HV Battery Malfunction	Abnormal signal input from battery ECU (HV battery system malfunction)	- HV battery system - Battery ECU	Comes on	Comes on	DTC stored	HV-466
P3000-125	HV Battery Malfunction	Abnormal signal input from battery ECU (High voltage fuse blown out)	- HV battery system - Battery ECU	Comes on	Comes on	DTC stored	HV-466
P3000-388	HV Battery Malfunction	Abnormal signal input from battery ECU (discharge inhibition control malfunction)	- HV control system - Fuel shortage - HV battery assembly	Comes on	-	DTC stored	HV-467

DTC No.	Detection Item	DTC Detection Condition	Trouble Area	Master Warning Light	MIL	Memory	See page
P3000-389	HV Battery Malfunction	Abnormal signal input from battery ECU (drop of high voltage)	- HV control system - HV battery assembly	Comes on	-	DTC stored	HV-469
P3000-603	HV Battery Malfunction	Abnormal signal input from battery ECU (HV battery cooling system malfunction)	- HV battery system - Battery ECU	Comes on	Comes on	DTC stored	HV-466
P3004-131	Power Cable Malfunction	High voltage fuse has blown out, service plug grip is disconnected or limiter resistance is cut off	- HV battery system - System main resistor - No. 1 system main relay - No. 3 system main relay - Main battery cable - No. 2 main battery cable - Frame wire - Inverter with converter assembly - HV control ECU	Comes on	-	DTC stored	HV-470
P3004-132	Power Cable Malfunction	Inverter voltage sensor malfunction, or limiter resistance increases	- HV battery system - System main resistor - No. 1 system main relay - No. 3 system main relay - Main battery cable - No. 2 main battery cable - Frame wire - Inverter with converter assembly - HV control ECU	Comes on	-	DTC stored	HV-477
P3004-133	Power Cable Malfunction	Abnormal signal input from battery ECU	- HV battery system - Battery ECU	-	-	DTC stored	HV-483
P3102-524	Transmission Control ECU Malfunction	BEAN communication problem of transmission control ECU assembly	- Wire harness or connector - Transmission control ECU assembly - HV control ECU - Power source control ECU	Comes on	-	DTC stored	HV-484

DTC No.	Detection Item	DTC Detection Condition	Trouble Area	Master Warning Light	MIL	Memory	See page
P3102-525	Transmission Control ECU Malfunction	Transmission control ECU IG OFF command malfunction	- Wire harness or connector - Transmission control ECU assembly - HV control ECU - Power source control ECU	Comes on	-	DTC stored	HV-484
P3102-581	Transmission Control ECU Malfunction	Transmission control ECU malfunction	- Wire harness or connector - Transmission control ECU assembly - HV control ECU - Power source control ECU	Comes on	-	DTC stored	HV-484
P3102-582	Transmission Control ECU Malfunction	P position (PPOS) signal is logically inconsistent	- Wire harness or connector - Transmission control ECU assembly - HV control ECU - Power source control ECU	Comes on	-	DTC stored	HV-484
P3102-597	Transmission Control ECU Malfunction	GND short in P position (PPOS) signal circuit	- Wire harness or connector - Transmission control ECU assembly - HV control ECU - Power source control ECU	Comes on	-	DTC stored	HV-484
P3102-598	Transmission Control ECU Malfunction	+B short in P position (PPOS) signal circuit	- Wire harness or connector - Transmission control ECU assembly - HV control ECU - Power source control ECU	Comes on	-	DTC stored	HV-484
P3102-599	Transmission Control ECU Malfunction	P position (PPOS) signal malfunction (output pulse is abnormal)	- Wire harness or connector - Transmission control ECU assembly - HV control ECU - Power source control ECU	Comes on	-	DTC stored	HV-484
P3107-213	Airbag ECU Communication Circuit Malfunction	GND short in communication circuit between center airbag sensor and HV control ECU	- Wire harness or connector - Center airbag sensor	Comes on	-	DTC stored	HV-489

DTC No.	Detection Item	DTC Detection Condition	Trouble Area	Master Warning Light	MIL	Memory	See page
P3107-214	Airbag ECU Communication Circuit Malfunction	Open or +B short in communication circuit between center airbag sensor and HV control ECU	- Wire harness or connector - Center airbag sensor	Comes on	-	DTC stored	HV-489
P3107-215	Airbag ECU Communication Circuit Malfunction	Abnormal communication signals between center airbag sensor and HV control ECU	- Wire harness or connector - Center airbag sensor	Comes on	-	DTC stored	HV-489
P3108-535	A/C Amplifier Communication Circuit Malfunction	Serial communication malfunction	- Wire harness or connector - Inverter with converter assembly	-	-	DTC stored	HV-491
P3108-536	A/C Amplifier Communication Circuit Malfunction	A/C inverter malfunction	- Wire harness or connector - Inverter with converter assembly	-	-	DTC stored	HV-491
P3108-537	A/C Amplifier Communication Circuit Malfunction	Air conditioning amplifier malfunction	- Air conditioning amplifier	-	-	DTC stored	HV-494
P3108-538	A/C Amplifier Communication Circuit Malfunction	Open in STB signal circuit	- Wire harness or connector - Inverter with converter assembly	-	-	DTC stored	HV-491
P3108-594	A/C Amplifier Communication Circuit Malfunction	CAN communication malfunction	- CAN communication system	-	-	DTC stored	HV-495
P3110-223	IGCT Relay Malfunction	IGCT relay is always closed	- Wire harness or connector - Integration relay (IGCT relay)	Comes on	-	DTC stored	HV-496
P3110-527	HV Main Relay Malfunction	IG2 logical inconsistency	- Wire harness or connector - Integration relay (IG2 relay)	Comes on	-	DTC stored	HV-496
P3137-348	Collision Sensor Low Input	GND short in No. 1 circuit breaker sensor circuit	- Wire harness or connector - No. 1 circuit breaker sensor	Comes on	-	DTC stored	HV-498
P3138-349	Collision Sensor High Input	Open or +B short in No. 1 circuit breaker sensor circuit	- Wire harness or connector - No. 1 circuit breaker sensor	Comes on	-	DTC stored	HV-498

DTC No.	Detection Item	DTC Detection Condition	Trouble Area	Master Warning Light	MIL	Memory	See page
P3221-314	Generator Inverter Temperature Sensor Circuit Range / Performance	Sudden change in generator inverter temperature sensor output	- Wire harness or connector - Inverter cooling system - Water pump with motor assembly - Cooling fan motor - No. 2 cooling fan motor - Inverter with converter assembly	Comes on	-	DTC stored	HV-500
P3221-315	Generator Inverter Temperature Sensor Circuit Range / Performance	Generator inverter temperature sensor output deviation	- Wire harness or connector - Inverter cooling system - Water pump with motor assembly - Cooling fan motor - No. 2 cooling fan motor - Inverter with converter assembly	Comes on	-	DTC stored	HV-500
P3222-313	Generator Inverter Temperature Sensor Circuit High / Low	Open or GND short in generator inverter temperature sensor circuit	- Wire harness or connector - Inverter with converter assembly - HV control ECU	Comes on	-	DTC stored	HV-505
P3223-312	Generator Inverter Temperature Sensor Circuit High	+B short in generator inverter temperature sensor circuit	- Wire harness or connector - Inverter with converter assembly - HV control ECU	Comes on	-	DTC stored	HV-505
P3226-562	DC/DC Boost Converter Temperature Sensor	Sudden change in boost converter temperature sensor output	- Wire harness or connector - Inverter cooling system - Water pump with motor assembly - Cooling fan motor - No. 2 cooling fan motor - Inverter with converter assembly	Comes on	-	DTC stored	HV-510

DTC No.	Detection Item	DTC Detection Condition	Trouble Area	Master Warning Light	MIL	Memory	See page
P3226-563	DC/DC Boost Converter Temperature Sensor	Boost converter temperature sensor output deviation	- Wire harness or connector - Inverter cooling system - Water pump with motor assembly - Cooling fan motor - No. 2 cooling fan motor - Inverter with converter assembly	Comes on	-	DTC stored	HV-510
U0100-211	Lost Communication with ECM / PCM "A"	CAN communication problem between ECM and HV control ECU (no signal input)	- CAN communication system	Comes on	Comes on	DTC stored	HV-515
U0100-212	Lost Communication with ECM / PCM "A"	CAN communication problem between ECM and HV control ECU (transmission error)	- CAN communication system	Comes on	Comes on	DTC stored	HV-515
U0100-530	Lost Communication with ECM / PCM "A"	CAN communication problem between ECM and HV control ECU (CAN communication system malfunction)	- CAN communication system	Comes on	Comes on	DTC stored	HV-515
U0111-208	Lost Communication with Battery Energy Control Module "A"	CAN communication problem between battery ECU and HV control ECU (no signal input)	- CAN communication system	Comes on	Comes on	DTC stored	HV-515
U0111-531	Lost Communication with Battery Energy Control Module "A"	CAN communication problem between battery ECU and HV control ECU (CAN communication system malfunction)	- CAN communication system	Comes on	Comes on	DTC stored	HV-515
U0129-220	Lost Communication with Brake System Control Module	CAN communication problem between skid control ECU and HV control ECU (no signal input)	- CAN communication system	Comes on	-	DTC stored	HV-515

DTC No.	Detection Item	DTC Detection Condition	Trouble Area	Master Warning Light	MIL	Memory	See page
U0129-222	Lost Communication with Brake System Control Module	CAN communication problem between skid control ECU and HV control ECU (CAN communication system malfunction)	- CAN communication system	Comes on	-	DTC stored	HV-515
U0129-528	Lost Communication with Brake System Control Module	CAN communication problem between skid control ECU and HV control ECU (transmission error)	- CAN communication system	Comes on	-	DTC stored	HV-515
U0129-529	Lost Communication with Brake System Control Module	CAN communication problem between skid control ECU and HV control ECU (regenerative torque malfunction)	- CAN communication system	Comes on	-	DTC stored	HV-515
U0131-433	Lost Communication with Power Steering Control Module	CAN communication problem between power steering ECU and HV control ECU (no signal input)	- CAN communication system	-	-	DTC stored	HV-515
U0131-434	Lost Communication with Power Steering Control Module	CAN communication problem between power steering ECU and HV control ECU (CAN communication system malfunction)	- CAN communication system	-	-	DTC stored	HV-515
U0146-435	Lost Communication with Gateway "A"	CAN communication problem between gateway ECU and HV control ECU (no signal input)	- CAN communication system	Comes on	-	DTC stored	HV-515

INFORMATION / FREEZE FRAME DATA

1. FREEZE FRAME DATA

HINT:

The freeze frame data records the driving condition when the DTC was set. It is used for estimating or simulating the condition of the vehicle when the malfunction occurred. To check the details of the hybrid vehicle control system, check the detailed information for the DTC (Information).

- (a) Connect the intelligent tester to the DLC3.
- (b) Turn the power switch ON (IG).
- (c) Turn the intelligent tester ON.
- (d) Enter the following menus: DIAGNOSIS / OBD/ MOBD / HV ECU / DTC INFO / CURRENT CODES.
- (e) Select a DTC in order to display its freeze frame data.
- (f) Check the freeze frame data of the DTC that has been detected.
- (g) Check information of the DTC (see below).

Freeze frame data:

Intelligent Tester Display	Measurement Item / Range (Display)	Suspected Vehicle Status When Malfunction Occurs
FREEZE DTC	DTC corresponding to displayed freeze frame data	-
COOLANT TEMP	Engine coolant temperature / Min.: -40°C, Max.: 140°C	Cold or warm engine
VEHICLE SPD	Vehicle speed / Min.: 0 km/h, Max.: 255 km/h	Stopped, or driving (low, medium, and high speeds)
ENG RUN TIME	Elapsed time after starting engine / Min.: 0 s, Max.: 65,535 s	Elapsed time from engine start
+B	Auxiliary battery voltage / Min.: 0 V, Max.: 65.535 V	Condition of auxiliary battery
ACCEL POS #1	No. 1 accelerator pedal position sensor / Min.: 0%, Max.: 100%	Idling, accelerating, or decelerating
ACCEL POS #2	No. 2 accelerator pedal position sensor / Min.: 0%, Max.: 100%	Idling, accelerating or decelerating (For comparison with above to detect failure of No. 1 accelerator pedal position sensor)
AMBIENT TEMP	Ambient air temperature / Min.: -40°C, Max.: 215°C	Ambient air temperature
INTAKE AIR TEMP	Intake air temperature / Min.: -40°C, Max.: 140°C	Ambient air temperature
DTC CLEAR WARM	The number of times engine is warmed up after clearing DTCs / Min.: 0, Max.: 255	Frequency of the malfunction recurrence after clearing DTCs
DTC CLEAR RUN	Drive distance after clearing DTCs / Min.: 0 km, Max.: 65,535 km	Frequency of the malfunction recurrence after clearing DTCs
DTC CLEAR MIN	Elapsed time after clearing DTCs / Min.: 0 min, Max.: 65,535 min	Frequency of the malfunction recurrence after clearing DTCs
ECU TYPE	Type of ECU	-
INFORMATION 1 to 5	Information code	-

2. INFORMATION

HINT:

Similar to freeze frame data, information records operating condition of the HV system and components at the time of detection of a DTC.

- (a) Select one which has an INF code from among INFORMATION 1 to 5.
- (b) Check the information of the DTC.

Information:

Intelligent Tester Display	Measurement Item / Range (Display)	Suspected Vehicle Status When Malfunction Occurs
INFORMATION N	Information code	Indication of system with malfunction
MG1 REV	MG1 revolution / Min.: -16,384 rpm, Max.: 16,256 rpm	MG1 speed <ul style="list-style-type: none"> • Forward rotation appears as "+" • Backward rotation appears as "-"
MG2 REV	MG2 revolution / Min.: -16,384 rpm, Max.: 16,256 rpm	MG2 speed (proportionate to vehicle speed) <ul style="list-style-type: none"> • Forward rotation appears as "+" • Backward rotation appears as "-" Moving direction of vehicle <ul style="list-style-type: none"> • Forward direction appears as "+" • Backward direction appears as "-"
MG1 TORQ	MG1 torque / Min.: -512 Nm, Max.: 508 Nm	When MG1 rotation in + direction: <ul style="list-style-type: none"> • Torque appears as "+" while MG1 discharges • Torque appears as "-" while MG1 charges When MG1 rotation in - direction: <ul style="list-style-type: none"> • Torque appears as "-" while MG1 discharges • Torque appears as "+" while MG1 charges
MG2 TORQ	MG2 torque / Min.: -512 Nm, Max.: 508 Nm	When MG2 rotation in + direction: <ul style="list-style-type: none"> • Torque appears as "+" while MG2 discharges • Torque appears as "-" while MG2 charges When MG2 rotation in - direction: <ul style="list-style-type: none"> • Torque appears as "-" while MG2 discharges • Torque appears as "+" while MG2 charges
INVERT TEMP-MG1	MG1 inverter temperature / Min.: -50°C, Max.: 205°C	MG1 inverter temperature
INVERT TEMP-MG2	MG2 inverter temperature / Min.: -50°C, Max.: 205°C	MG2 inverter temperature
MG2 TEMP (No2)	Transaxle fluid temperature / Min.: -50°C, Max.: 205°C	Transaxle fluid temperature
MG2 TEMP (No1)	MG2 temperature / Min.: -50°C, Max.: 205°C	MG2 temperature
POWER RQST	Request engine power / Min.: 0 W, Max.: 255 kW	Engine power output requested to ECM
ENGINE SPD	Engine speed / Min.: 0 rpm, Max.: 16,320 rpm	Engine speed
MCYL CTRL POWER	Master cylinder control torque / Min.: -512 Nm, Max.: 508 Nm	Brake force requested by driver
SOC	Battery state of charge / Min.: 0%, Max.: 100%	State of charge of HV battery
WOUT CTRL POWER	Power value discharge control / Min.: 0 W, Max.: 81,600 W	Discharge amount of HV battery
WIN CTRL POWER	Power value charge control / Min.: -40,800 W, Max.: 0 W	Charge amount of HV battery
DRIVE CONDITION	Drive condition ID <ul style="list-style-type: none"> • Engine stopped: 0 • Engine about to be stopped: 1 • Engine about to be started: 2 • Engine operated or operating: 3 • Generating or loading movement: 4 • Revving up with P position: 6 	Engine operating condition
PWR RESOURCE VB	HV battery voltage / Min.: 0 V, Max.: 510 V	HV battery voltage

Intelligent Tester Display	Measurement Item / Range (Display)	Suspected Vehicle Status When Malfunction Occurs
PWR RESOURCE IB	HV battery current / Min.: -256 A, Max.: 254 A	Charging / discharging state of HV battery <ul style="list-style-type: none"> Discharging amperage indicated by a positive value Charging amperage indicated by a negative value
SHIFT POSITION	Shift position (P, R, N, D or B position) P: 0, R: 1, N: 2, D: 3, B: 4	Shift position
ACCEL SENSOR M	Accelerator pedal position sensor main / Min.: 0%, Max.: 100%	Idling, accelerating, or decelerating
AUX. BATT V	Auxiliary battery voltage / Min.: 0 V, Max.: 20 V	State of auxiliary battery
CONVERTER TEMP	Boost converter temperature / Min.: -50°C, Max.: 205°C	Boost converter temperature
VL	High voltage before it is boosted / Min.: 0 V, Max.: 510 V	High voltage level before it is boosted
VH	High voltage after it is boosted / Min.: 0 V, Max.: 765 V	High voltage level after it is boosted
IG ON TIME	The time after power switch ON (IG) / Min.: 0 min, Max.: 255 min	Time elapsed with power switch ON (IG)
VEHICLE SPD-MAX	Maximum vehicle speed / Min.: -256 km/h, Max.: 254 km/h	Maximum vehicle speed
A/C CONSMPT PWR	A/C consumption power / Min.: 0 kW, Max.: 5 kW	A/C load
ENG STOP RQST	Engine stop request / NO or YES	Presence of engine stop request
IDLING REQUEST	Engine idling request / NO or YES	Presence of idle stop request
ENGINE FUEL CUT	Engine fuel cut request / NO or YES	Presence of fuel cut request
HV BATT CH RQST	HV battery charging request / NO or YES	Presence of HV battery charging request
ENG WARM UP RQT	Engine warming up request / NO or YES	Presence of engine warm-up request
STOP SW COND	Stop light switch ON condition / NO or YES	Brake pedal depressed or released
CRUISE CONTROL	Cruise control active condition / NO or YES	Operation under cruise control ON or OFF
EXCLUSIVE INFO 1 to 7	Exclusive information (in form of numerical data)	Exclusive Information linked to Information
OCCURRENCE ORDER	Occurrence sequence of information	Occurrence sequence of information
INVT TMP-MG1 IG	MG1 inverter temperature after power switch ON (IG) / Min.: -50°C, Max.: 205°C	MG1 inverter temperature soon after power switch ON (IG)
INVT TMP-MG2 IG	MG2 inverter temperature after power switch ON (IG) / Min.: -50°C, Max.: 205°C	MG2 inverter temperature soon after power switch ON (IG)
MG2 TEMP IG	MG2 temperature after power switch ON (IG) / Min.: -50°C, Max.: 205°C	MG2 temperature soon after power switch ON (IG)
CONVRTR TEMP IG	Boost converter temperature after power switch ON (IG) / Min.: -50°C, Max.: 205°C	Boost converter temperature soon after power switch ON (IG)
SOC IG	Battery state of charge after power switch ON (IG) / Min.: 0%, Max.: 100%	Battery state of charge soon after power switch ON (IG)
INVT TMP-MG1MAX	MG1 inverter maximum temperature / Min.: -50°C, Max.: 205°C	Overheating state of MG1 inverter

Intelligent Tester Display	Measurement Item / Range (Display)	Suspected Vehicle Status When Malfunction Occurs
INVT TMP-MG2MAX	MG2 inverter maximum temperature / Min.: -50°C, Max.: 205°C	Overheating state of MG2 inverter
MG2 TEMP MAX	MG2 maximum temperature / Min.: -50°C, Max.: 205°C	Overheating state of MG2
CONVRTR TMP MAX	Boost converter maximum temperature / Min.: -50°C, Max.: 205°C	Overheating state of boost converter
SOC MAX	Maximum status of charge / Min.: 0%, Max.: 100%	Over-charging of HV battery
SOC MIN	Minimum status of charge / Min.: 0%, Max.: 100%	Over-discharging of HV battery

OPERATION HISTORY DATA

1. OPERATION HISTORY DATA

HINT:

The operation history data records the special operations performed by the driver and the number of abnormal conditions that have been input into the HV control ECU.

- (a) Connect the intelligent tester to the DLC3.
- (b) Turn the power switch ON (IG).
- (c) Turn the intelligent tester ON.
- (d) Enter the following menus: DIAGNOSIS / OBD/ MOBD / HV ECU / DATA LIST.
- (e) Select the menu to view the number of special operations or controls that have been effected.

HINT:

- LATEST OPER: Among the past occurrences, the number of special operations or controls that have been effected during the most recent 1 trip detection.
- LATEST TRIP: The number of trips after the occurrence of LATEST OPER.
- BEF LATEST OPER: The number of occurrences 1 previously from the LATEST OPER.
- BEF LATEST TRIP: The number of trips after the occurrence of BEF LATEST OPER.

Operation history data:

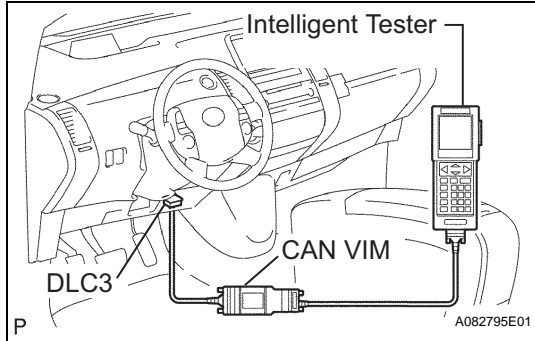

Intelligent Tester Display	Count Condition
SHIFT BEF READY	Shift lever moved with READY light blinking
N RANGE CTRL 2	N position control effected due to frequent shifting operation
STEP ACCEL IN N	Accelerator pedal depressed in N position
AUX. BATT LOW	Auxiliary battery voltage below 9.5 V
HV INTERMITTENT	Instantaneous open at IGSW terminal of HV control ECU
MG2 (NO1) TEMP HI	Motor temperature rose above 174°C (345°F)
MG2 (NO2) TEMP HI	Transaxle fluid temperature rose above 162°C (324°F)
MG2 INV TEMP HI	Motor inverter temperature rose above 111°C (232°F)
MG1 INV TEMP HI	Generator inverter temperature rose above 111°C (232°F)
MAIN BATT LOW	Battery state of charge dropped below 30%
RESIST OVR HEAT	Limit resistor forecast temperature rose above 120°C (248°F)
COOLANT HEAT	Inverter coolant forecast temperature rose above 65°C (149°F)
CONVERTER HEAT	Boost converter temperature rose above 111°C (232°F)
SHIFT P IN RUN	Shifted to P while driving
BKWRD DIR SHIFT	Shifted to R while moving forward or to D or B while moving in reverse
PREVENT STAYING	Engine speed stays in resonance frequency band

HV

DTC	P0336-137	Crankshaft Position Sensor "A" Circuit Range / Performance
------------	------------------	---

DTC	P0340-532	Camshaft Position Sensor "A" Circuit
------------	------------------	---

DESCRIPTION

If there is any malfunction in the communication values or pulse inputs, the HV control ECU detects it by comparing the following three speeds: the engine speed transmitted by the ECM via CAN (Controller Area Network) communication, the engine speed obtained through pulse inputs, and the engine speed calculated from the MG1 and MG2 speeds.

DTC No.	INF Code	DTC Detection Condition	Trouble Area
P0336	137	Engine speed sensor deviation malfunction (CAN communication)	<ul style="list-style-type: none"> • Wire harness or connector • Crankshaft position sensor • Camshaft position sensor • HV control ECU
P0340	532	Engine speed sensor deviation malfunction (pulse signal)	<ul style="list-style-type: none"> • Wire harness or connector • Crankshaft position sensor • Camshaft position sensor • HV control ECU

WIRING DIAGRAM

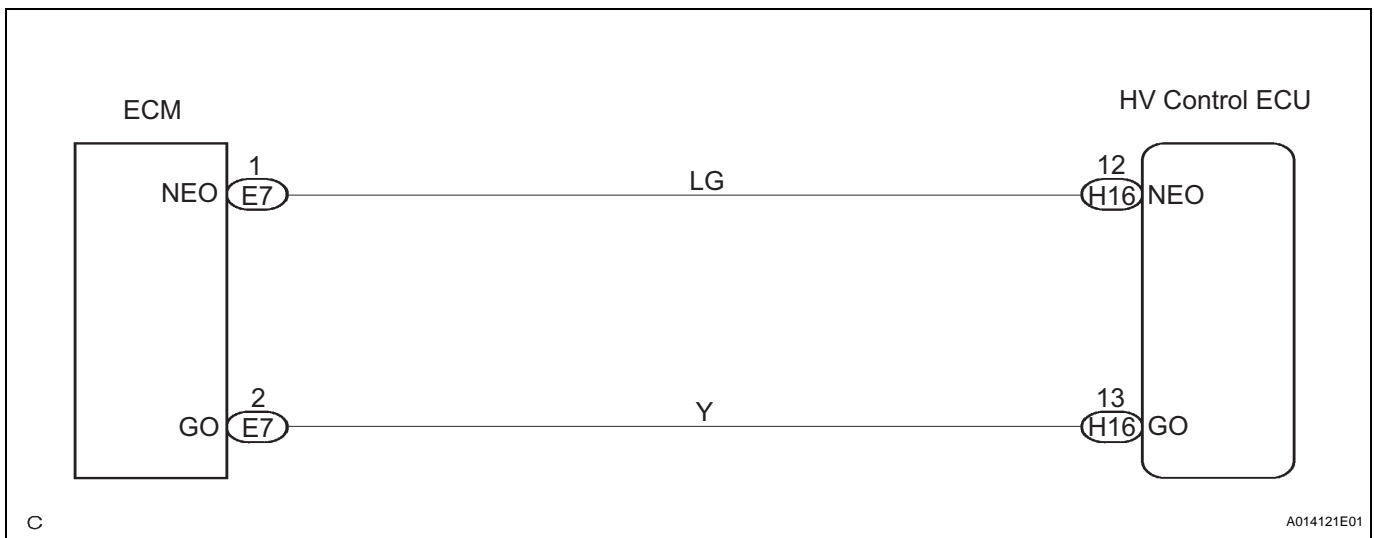

HV

INSPECTION PROCEDURE

1	READ OUTPUT DTC (ENGINE)
----------	---------------------------------

- (a) Connect the intelligent tester to the DLC3.
- (b) Turn the power switch ON (IG).
- (c) Turn the intelligent tester ON.
- (d) Enter the following menus: DIAGNOSIS / ENHANCED OBD II / DTC INFO / CURRENT CODES.
- (e) Read DTCs.

Result:

DTCs are output.

YES	GO TO RELEVANT DTC CHART
------------	---------------------------------

NO

2 CHECK HARNESS AND CONNECTOR (HYBRID VEHICLE CONTROL ECU - ECM)

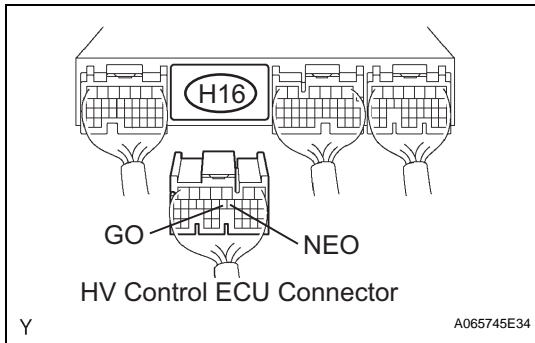

(a) Disconnect the H16 HV control ECU connector.

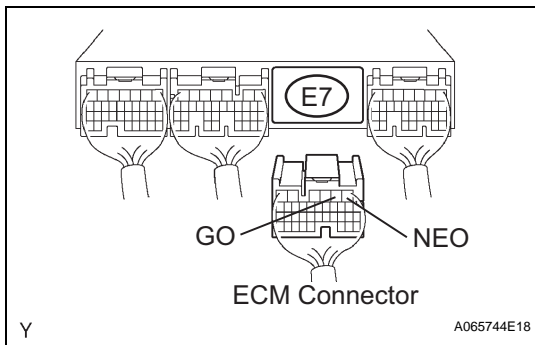

(b) Disconnect the E7 ECM connector.

(c) Measure the resistance between the wire harness side connectors.

Standard resistance (Check for open)

Tester Connection	Specified Condition
NEO (H16-12) - NEO (E7-1)	Below 1 Ω
GO (H16-13) - GO (E7-2)	Below 1 Ω

Standard resistance (Check for short)

Tester Connection	Specified Condition
NEO (H16-12) or NEO (E7-1) - Body ground	10 kΩ or higher
GO (H16-13) or GO (E7-2) - Body ground	10 kΩ or higher

(d) Reconnect the ECM connector.

(e) Reconnect the HV control ECU connector.

NG REPAIR OR REPLACE HARNESS OR CONNECTOR

OK

3 INSPECT CRANKSHAFT POSITION SENSOR

(a) Inspect crankshaft position sensor (see page [ES-443](#)).

NG REPLACE CRANKSHAFT POSITION SENSOR

OK

4 INSPECT CAMSHAFT POSITION SENSOR

(a) Inspect camshaft position sensor (see page [ES-440](#)).

NG REPLACE CAMSHAFT POSITION SENSOR

HV

OK

REPLACE HYBRID VEHICLE CONTROL ECU

DTC	P0338-600	Crankshaft Position Sensor "A" Circuit High Input
------------	------------------	--

DTC	P0343-601	Camshaft Position Sensor "A" Circuit High Input
------------	------------------	--

DESCRIPTION

Refer to DTC P0336 (INF 137) (see page HV-91).

DTC No.	INF Code	DTC Detection Condition	Trouble Area
P0338	600	NEO signal circuit malfunction	<ul style="list-style-type: none"> • Wire harness or connector • HV control ECU
P0343	601	GO signal circuit malfunction	<ul style="list-style-type: none"> • Wire harness or connector • HV control ECU

WIRING DIAGRAM

Refer to DTC P0336 (INF 137) (see page HV-91).

INSPECTION PROCEDURE

1	READ OUTPUT DTC (ENGINE)
----------	---------------------------------

- (a) Connect the intelligent tester to the DLC3.
- (b) Turn the power switch ON (IG).
- (c) Turn the intelligent tester ON.
- (d) Enter the following menus: DIAGNOSIS / ENHANCED OBD II / DTC INFO / CURRENT CODES.
- (e) Read DTCs.

Result:

DTCs are output



2	CHECK HARNESS AND CONNECTOR (HYBRID VEHICLE CONTROL ECU - ECM)
----------	---

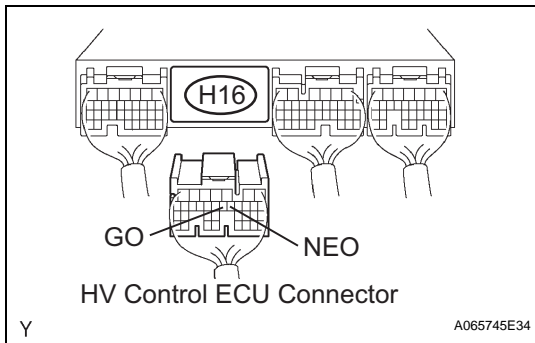

- (a) Disconnect the H16 HV control ECU connector.

HV

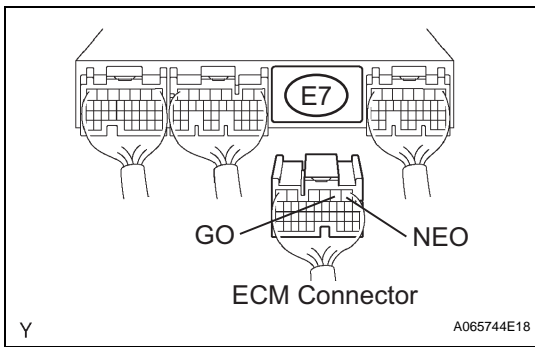

- (b) Disconnect the E7 ECM connector.
- (c) Measure the resistance between the wire harness side connectors.

Standard resistance (Check for open)

Tester Connection	Specified Condition
NEO (H16-12) - NEO (E7-1)	Below 1 Ω
GO (H16-13) - GO (E7-2)	Below 1 Ω

Standard resistance (Check for short)

Tester Connection	Specified Condition
NEO (H16-12) or NEO (E7-1) - Body ground	10 kΩ or higher
GO (H16-13) or GO (E7-2) - Body ground	10 kΩ or higher

- (d) Reconnect the ECM connector.
- (e) Reconnect the HV control ECU connector.

NG → **REPAIR OR REPLACE HARNESS OR CONNECTOR**

OK

3 INSPECT OUTPUT WAVEFORM

- (a) Inspect the ECM using an oscilloscope.
 - (1) While the engine is idling, check the waveform between the terminals of the HV control ECU connector.

Standard voltage

Tester Connection	Specified Condition
NEO (H16-12) - GND1 (H14-1)	Correct waveform appears as shown
GO (H16-13) - GND1 (H14-1)	Correct waveform appears as shown

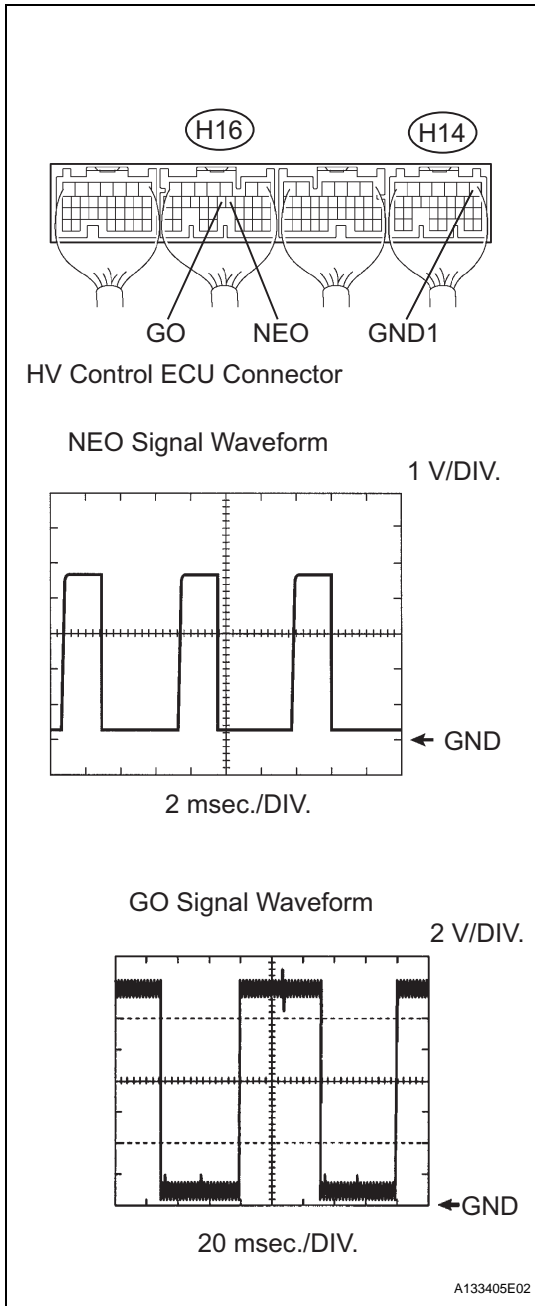

NG → **REPLACE ECM**

HV

OK

REPLACE HYBRID VEHICLE CONTROL ECU

A133405E02

DTC	P0560-117	System Voltage
------------	------------------	-----------------------

DESCRIPTION

Since the ECU back-up power source is used for DTCs and freeze frame data memory, the back-up power source (BATT) continues to be supplied to the HV control ECU even if the power switch is turned OFF.

DTC No.	INF Code	DTC Detection Condition	Trouble Area
P0560	117	HV control ECU back-up power source circuit malfunction	<ul style="list-style-type: none"> Wire harness or connector HEV fuse

MONITOR DESCRIPTION

If 3 or more seconds have elapsed with a voltage of less than 2.5 V at the BATT terminal at the HV control ECU, the HV control ECU will determine that a malfunction has occurred in the back-up power supply system, and set a DTC. It will illuminate the MIL the next time the engine is started.

MONITOR STRATEGY

Related DTCs	P0560 (INF 117): Battery signal malfunction
Required sensor / components	Main: Back-up power source circuit Sub: Hybrid vehicle control ECU
Frequency of operation	Continuous
Duration	3 seconds
MIL operation	Immediate after next power switch ON (IG)
Sequence of operation	None

TYPICAL ENABLING CONDITIONS

The monitor will run whenever the following DTCs are not present	TOYOTA's intellectual property
A/D converter	Normal
Auxiliary battery voltage	More than 9.5 V

HV

TYPICAL MALFUNCTION THRESHOLDS

Condition (a) or (b) is met	-
(a) Input voltage for BATT signal	Less than 2.5 V
(b) Abnormal flag for SRAM	ON

COMPONENT OPERATING RANGE

Auxiliary battery voltage	Between 9 and 14 V
---------------------------	--------------------

WIRING DIAGRAM

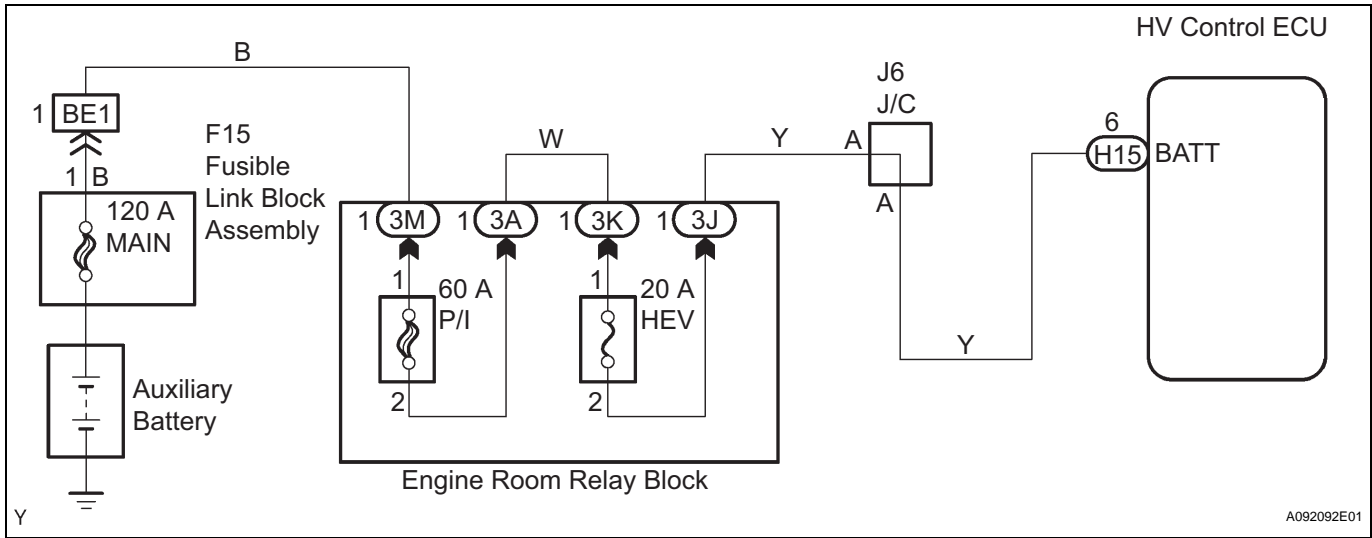

INSPECTION PROCEDURE

1 INSPECT FUSE (HEV 20 A)

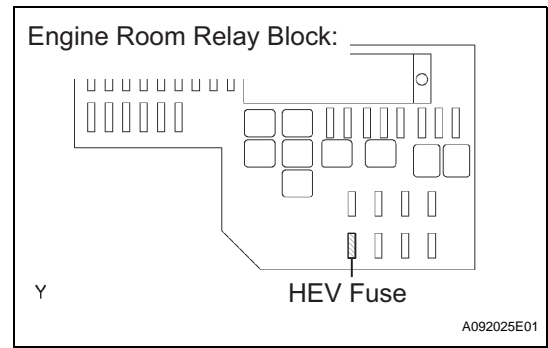

- (a) Remove the HEV fuse from the engine room relay block.
- (b) Measure the resistance of the HEV fuse.
Standard resistance:
Below 1 Ω
- (c) Reinstall the HEV fuse.

NG → **Go to step 3**

OK

2 CHECK HARNESS AND CONNECTOR (HYBRID VEHICLE CONTROL ECU - AUXILIARY BATTERY)

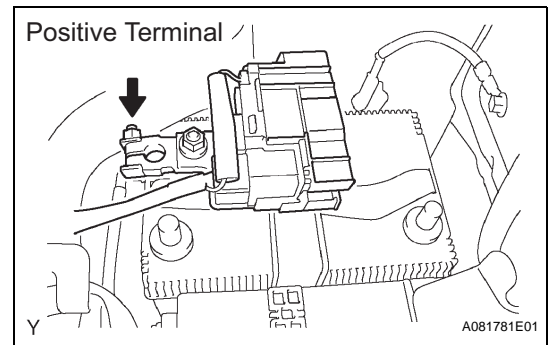

- (a) Disconnect the negative auxiliary battery terminal.
- (b) Disconnect the positive auxiliary battery terminal.

HV

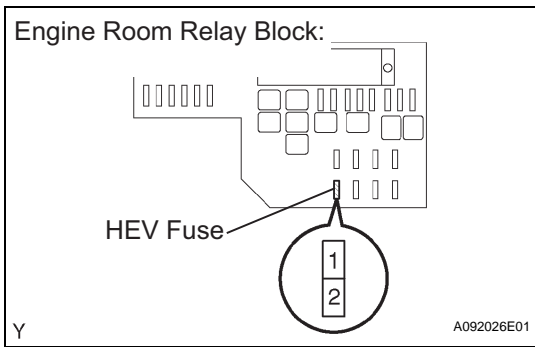

(c) Remove the HEV fuse from the engine room relay block.

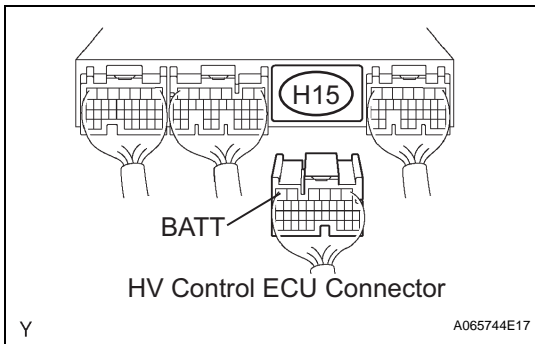

(d) Disconnect the H15 HV control ECU connector.

(e) Measure the resistance between the wire harness side connectors.

Standard resistance (Check for open)

Tester Connection	Specified Condition
BATT (H15-6) - HEV fuse (2)	Below 1 Ω

NOTICE:

When taking a measurement with a tester, do not apply excessive force to the tester probe to avoid damaging the holder.

(f) Measure the resistance between the wire harness side connectors.

Standard resistance (Check for open)

Tester Connection	Specified Condition
HEV fuse (1) - Positive auxiliary battery terminal	Below 1 Ω

NOTICE:

When taking a measurement with a tester, do not apply excessive force to the tester probe to avoid damaging the holder.

(g) Reconnect the HV control ECU connector.

(h) Reinstall the HEV fuse.

(i) Reconnect the positive auxiliary battery terminal.

(j) Reconnect the negative auxiliary battery terminal.

NG **REPAIR OR REPLACE HARNESS OR CONNECTOR**

OK

CHECK AND REPAIR CONNECTOR CONNECTION

3 CHECK HARNESS AND CONNECTOR (HYBRID VEHICLE CONTROL ECU - HEV FUSE)

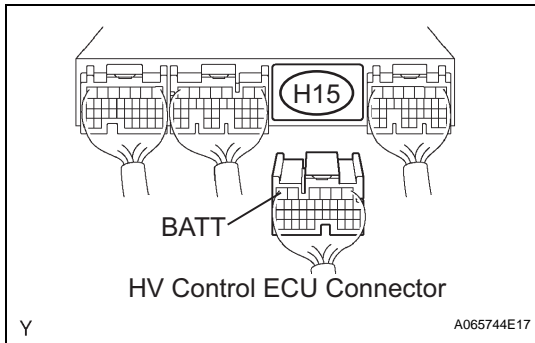

(a) Disconnect the H15 HV control ECU connector.

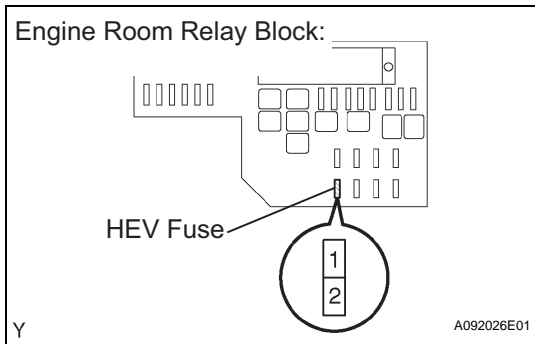

(b) Remove the HEV fuse from the engine room relay block.
 (c) Measure the resistance between the wire harness side connectors.

Standard resistance (Check for short)

Tester Connection	Specified Condition
BATT (H15-6) or HEV fuse (2) - Body ground	10 kΩ or higher

NOTICE:

When taking a measurement with a tester, do not apply excessive force to the tester probe to avoid damaging the holder.

(d) Reinstall the HEV fuse.
 (e) Reconnect the HV control ECU connector.

NG **AFTER REPAIRING OR REPLACING HARNESS OR CONNECTOR, REPLACE FUSE (HEV 20 A)**

OK

REPLACE FUSE (HEV 20 A)

HV

DTC**P0630-804****VIN not Programmed or Mismatch-ECM / PCM****DESCRIPTION**

DTC P0630 is set if the Vehicle Identification Number (VIN) is not stored in the HV control ECU or the input VIN is not accurate. Input the VIN with the intelligent tester (see page [HV-22](#)).

DTC No.	INF No.	DTC Detection Condition	Trouble Area
P0630	804	<ul style="list-style-type: none"> • VIN not stored in HV control ECU • Input VIN in HV control ECU not accurate 	HV control ECU

INSPECTION PROCEDURE**1****READ CURRENT DTC****NOTICE:**

If P0630 is set, the VIN must be input to the HV control ECU using the intelligent tester. However, all DTCs are cleared automatically by the tester when inputting the VIN. If DTCs other than P0630-804 are set, check them first.

NEXT**2****INPUT VIN WITH INTELLIGENT TESTER**

- (a) Input the VIN with intelligent tester (see page [HV-22](#)).

NOTICE:

Be sure to check the auxiliary battery voltage before performing VIN writing because VIN writing cannot be performed if the auxiliary battery voltage is below 10 V.

HV**NEXT****3****READ OUTPUT DTC**

- (a) Connect the intelligent tester to the DLC3.
 (b) Turn the power switch ON (IG).
 (c) Select the following menu items: DIAGNOSIS / OBD/ MOBD / HV ECU / DTC INFO / CURRENT CODES.
 (d) Read output DTC (see page [HV-39](#)).

OK:

DTC P0630-804 is not output.

NG**REPLACE HYBRID VEHICLE CONTROL ECU****OK****END**

DTC	P0705-571	Transmission Range Sensor Circuit
DTC	P0705-572	Transmission Range Sensor Circuit
DTC	P0705-573	Transmission Range Sensor Circuit
DTC	P0705-574	Transmission Range Sensor Circuit
DTC	P0705-575	Transmission Range Sensor Circuit
DTC	P0705-576	Transmission Range Sensor Circuit
DTC	P0705-577	Transmission Range Sensor Circuit
DTC	P0705-578	Transmission Range Sensor Circuit
DTC	P0705-595	Transmission Range Sensor Circuit
DTC	P0705-596	Transmission Range Sensor Circuit

DESCRIPTION**HINT:**

- The shift control system is a linkless type that does not use a shift cable.
- The shift and select sensors are a non-contact type.

The selector lever is a momentary type, which returns to its home position by spring reaction as the driver's hand is released from the selector lever after shifting. The selector lever contains a shift sensor and a select sensor to detect the selector lever position (R, N, D or B). Because both sensors are controlled electrically by Hall elements, they can accurately detect shift positions in a reliable manner. Both sensors contain two systems of detection circuits, main and sub.

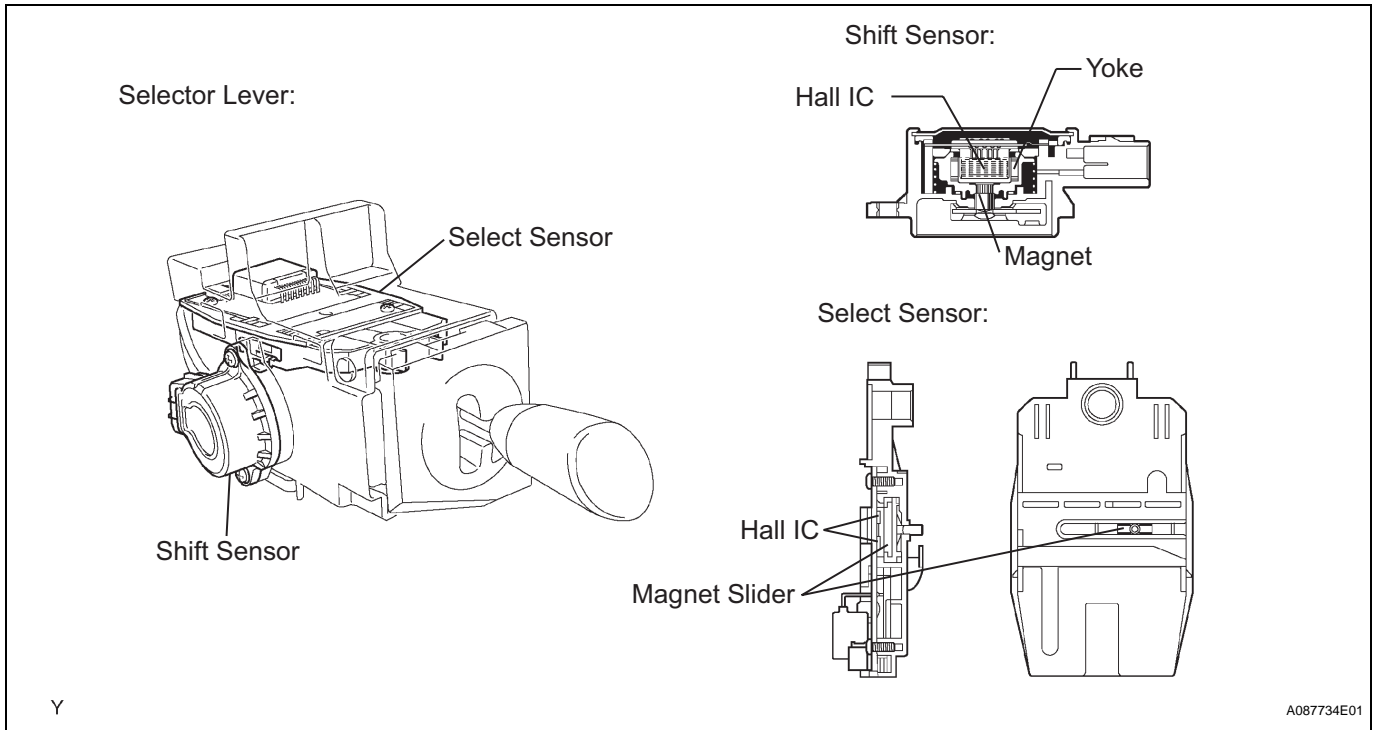

The shift sensor outputs voltage, which varies between 0 and 5 V in accordance with the vertical movement of the selector lever, to the HV control ECU. The HV control ECU interprets low level voltage as the D or B position, middle level voltage as the home or N position, and high level voltage as the R position.

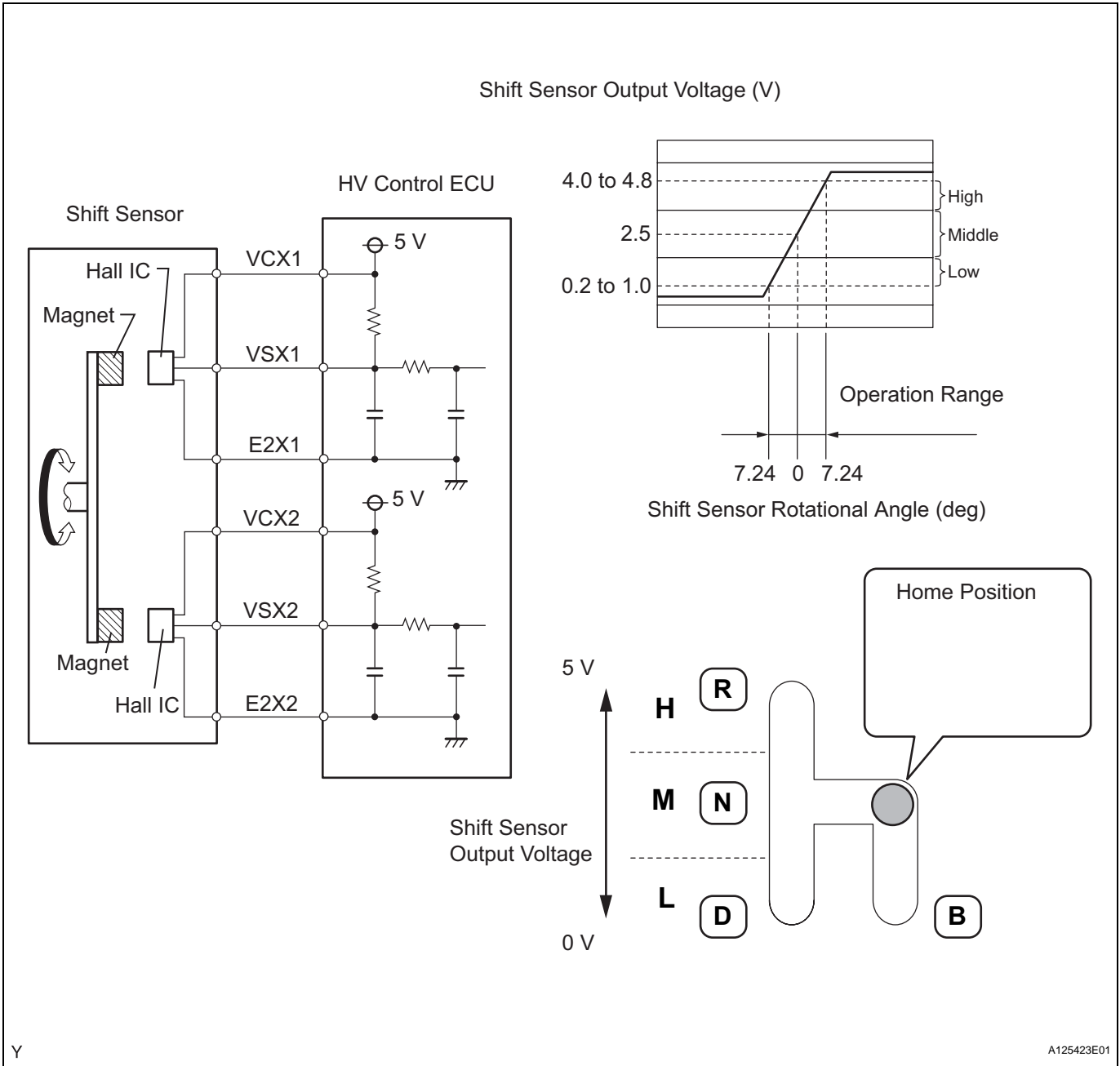

HV

The select sensor outputs voltage, which varies between 0 and 5 V in accordance with the horizontal movement of the selector lever, to the HV control ECU. The HV control ECU interprets low level voltage as the home or B position, and high level voltage as the R, N, or D position. The HV control ECU determines the position of the selector lever in accordance with the combination of the signals from the shift sensor and select sensor.

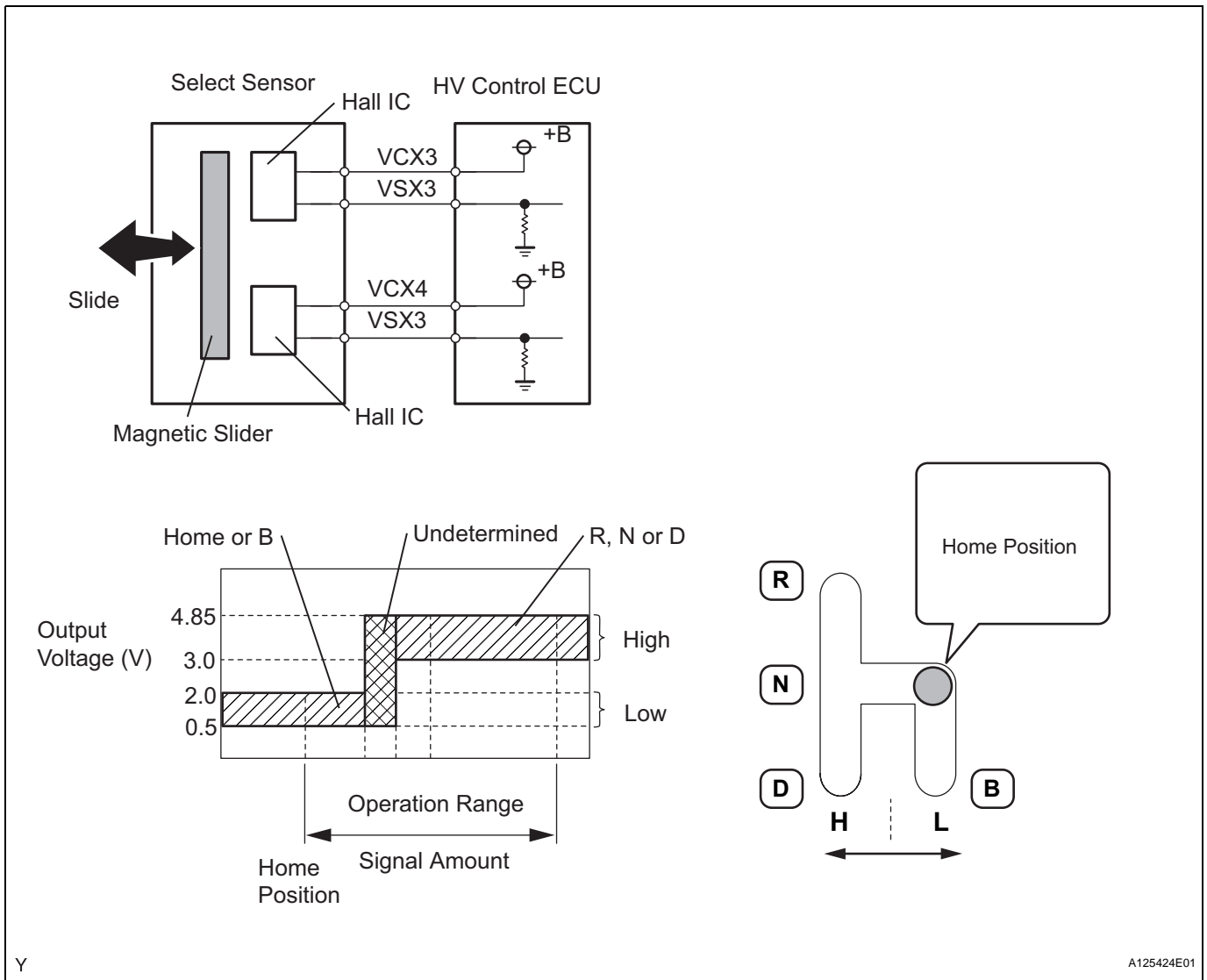

HV

DTC No.	INF Code	DTC Detection Condition	Trouble Area
P0705	571	Open or GND short in shift main sensor circuit	<ul style="list-style-type: none"> Wire harness or connector Selector lever HV control ECU
P0705	572	+B short in shift main sensor circuit	<ul style="list-style-type: none"> Wire harness or connector Selector lever HV control ECU
P0705	573	Open or GND short in shift sub sensor circuit	<ul style="list-style-type: none"> Wire harness or connector Selector lever HV control ECU
P0705	574	+B short in shift sub sensor circuit	<ul style="list-style-type: none"> Wire harness or connector Selector lever HV control ECU
P0705	575	Open or GND short in select main sensor circuit	<ul style="list-style-type: none"> Wire harness or connector Selector lever HV control ECU

DTC No.	INF Code	DTC Detection Condition	Trouble Area
P0705	576	+B short in select main sensor circuit	<ul style="list-style-type: none"> Wire harness or connector Selector lever HV control ECU
P0705	577	Open or GND short in select sub sensor circuit	<ul style="list-style-type: none"> Wire harness or connector Selector lever HV control ECU
P0705	578	+B short in select sub sensor circuit	<ul style="list-style-type: none"> Wire harness or connector Selector lever HV control ECU
P0705	595	Difference between shift main sensor value and shift sub sensor value is large	<ul style="list-style-type: none"> Wire harness or connector Selector lever HV control ECU
P0705	596	Difference between select main sensor value and select sub sensor value is large	<ul style="list-style-type: none"> Wire harness or connector Selector lever HV control ECU

HINT:

After confirming DTC P0705 (INF 571, 572, 573, or 574), confirm M and S SHIFT SENSOR voltages using the intelligent tester.

M and S SHIFT SENSOR

R Position (Main)	Home or N Position (Main)	D or B Position (Main)	R Position (Sub)	Home or N Position (Sub)	D or B Position (Sub)	Trouble Area
0 to 0.2 V	0 to 0.2 V	0 to 0.2 V	4.0 to 4.8 V	2.0 to 3.0 V	0.2 to 1.0 V	Open in VCX1 circuit
4.0 to 4.8 V	2.0 to 3.0 V	0.2 to 1.0 V	0 to 0.2 V	0 to 0.2 V	0 to 0.2 V	Open in VCX2 circuit
0 to 0.2 V	0 to 0.2 V	0 to 0.2 V	4.0 to 4.8 V	2.0 to 3.0 V	0.2 to 1.0 V	Open or short in VSX1 circuit
4.0 to 4.8 V	2.0 to 3.0 V	0.2 to 1.0 V	0 to 0.2 V	0 to 0.2 V	0 to 0.2 V	Open or short in VSX2 circuit
4.8 to 5.0 V	4.8 to 5.0 V	4.8 to 5.0 V	4.0 to 4.8 V	2.0 to 3.0 V	0.2 to 1.0 V	Open in E2X1 circuit
4.0 to 4.8 V	2.0 to 3.0 V	0.2 to 1.0 V	4.8 to 5.0 V	4.8 to 5.0 V	4.8 to 5.0 V	Open in E2X2 circuit

HINT:

After confirming DTC P0705 (INF 575, 576, 577, or 578), confirm SM and SS SHIFT SENSOR voltages using the intelligent tester.

SM and SS SHIFT SENSOR

R, N or D Position (Select Main)	Home or B Position (Select Main)	R, N or D Position (Select Sub)	Home or B Position (Select Sub)	Trouble Area
0 to 0.5 V	0 to 0.5 V	3.0 to 4.85 V	0.5 to 2.0 V	Open or GND short in VCX3 or VSX3 circuit
3.0 to 4.85 V	0.5 to 2.0 V	0 to 0.5 V	0 to 0.5 V	Open or GND short in VCX4 or VSX4 circuit

WIRING DIAGRAM

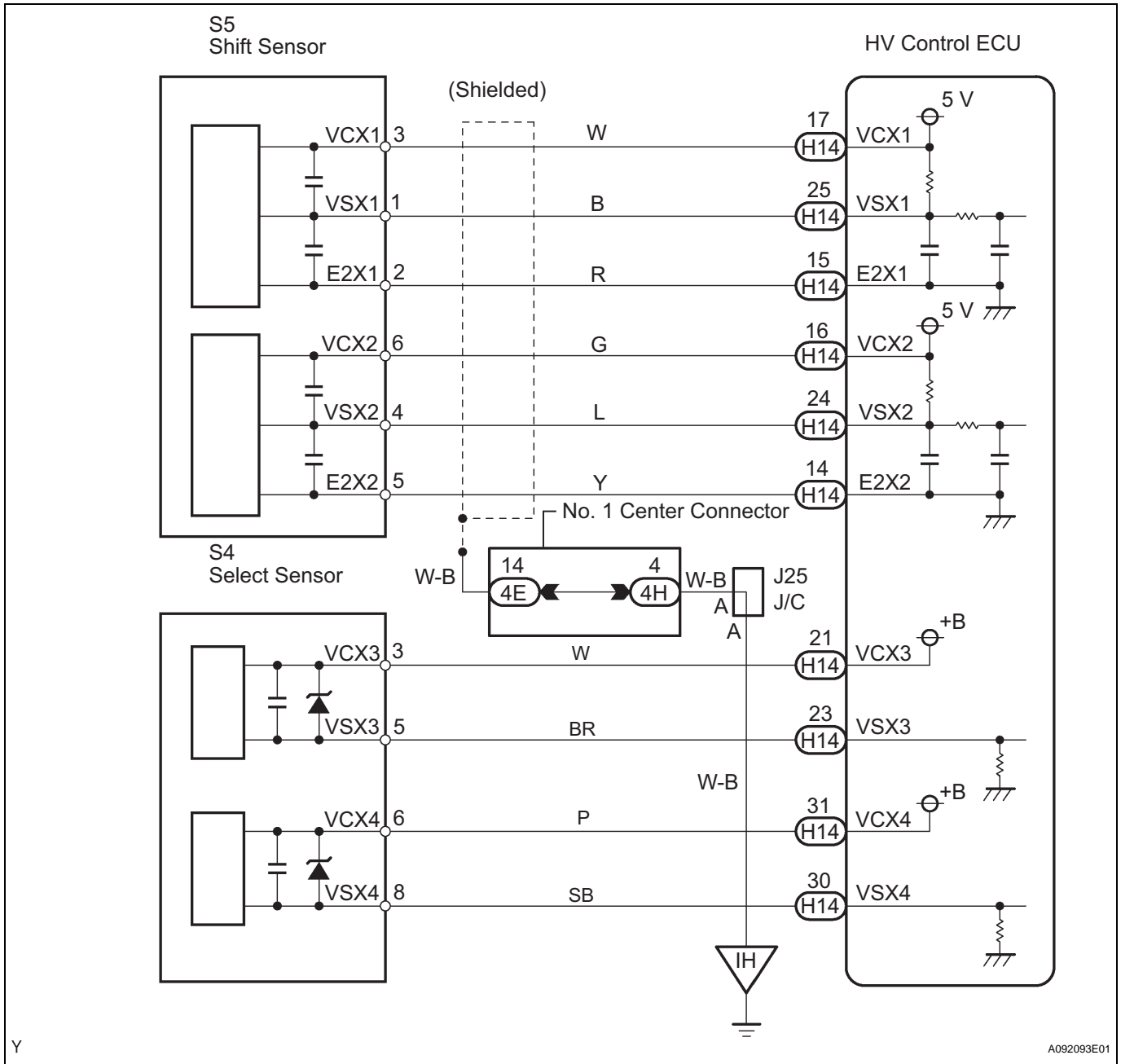

HV

INSPECTION PROCEDURE

1 READ VALUE OF INTELLIGENT TESTER (M AND S SHIFT SENSOR)

- (a) Connect the intelligent tester to the DLC3.
- (b) Turn the power switch ON (IG).
- (c) Turn the intelligent tester ON.
- (d) Enter the following menus: DIAGNOSIS / OBD/MOBD / HV ECU / DATA LIST.
- (e) Read the M and S SHIFT SENSOR voltage values.

Result:

Shift Position	M Shift Sensor	S Shift Sensor
R position	4.0 to 4.8 V	4.0 to 4.8 V

Shift Position	M Shift Sensor	S Shift Sensor
Home or N position	2.0 to 3.0 V	2.0 to 3.0 V
D or B position	0.2 to 1.0 V	0.2 to 1.0 V

OK Go to step 4

NG

2 CHECK HARNESS AND CONNECTOR (HYBRID VEHICLE CONTROL ECU - SHIFT SENSOR)

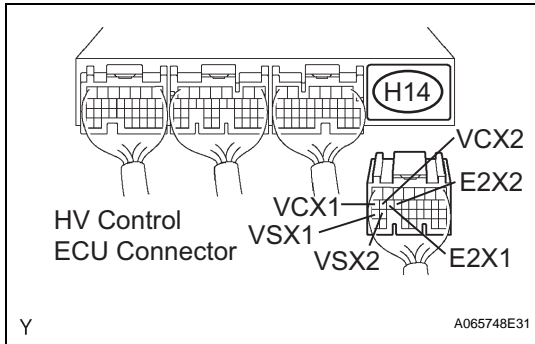

(a) Disconnect the H14 HV control ECU connector.

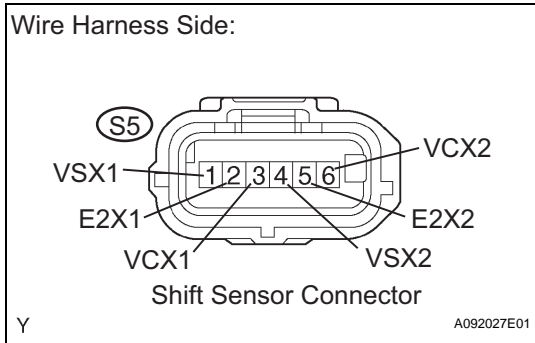

- (b) Disconnect the S5 shift sensor connector.
- (c) Turn the power switch ON (IG).
- (d) Measure the voltage between the terminals of the HV control ECU connector and body ground.

Standard voltage

Tester Connection	Specified Condition
VCS1 (H14-17) - Body ground	Below 1 V
VSX1 (H14-25) - Body ground	Below 1 V
E2X1 (H14-15) - Body ground	Below 1 V
VCS2 (H14-16) - Body ground	Below 1 V
VSX2 (H14-24) - Body ground	Below 1 V
E2X2 (H14-14) - Body ground	Below 1 V

- (e) Turn the power switch OFF.
- (f) Measure the resistance between the wire harness side connectors.

Standard resistance (Check for open)

Tester Connection	Specified Condition
VCS1 (H14-17) - VCS1 (S5-3)	Below 1 Ω
VSX1 (H14-25) - VSX1 (S5-1)	Below 1 Ω
E2X1 (H14-15) - E2X1 (S5-2)	Below 1 Ω
VCS2 (H14-16) - VCS2 (S5-6)	Below 1 Ω
VSX2 (H14-24) - VSX2 (S5-4)	Below 1 Ω
E2X2 (H14-14) - E2X2 (S5-5)	Below 1 Ω

Standard resistance (Check for short)

Tester Connection	Specified Condition
VCS1 (H14-17) or VCS1 (S5-3) - Body ground	10 kΩ or higher
VSX1 (H14-25) or VSX1 (S5-1) - Body ground	10 kΩ or higher

HV

Tester Connection	Specified Condition
E2X1 (H14-15) or E2X1 (S5-2) - Body ground	10 kΩ or higher
VCX2 (H14-16) or VCX2 (S5-6) - Body ground	10 kΩ or higher
VSX2 (H14-24) or VSX2 (S5-4) - Body ground	10 kΩ or higher
E2X2 (H14-14) or E2X2 (S5-5) - Body ground	10 kΩ or higher

- (g) Reconnect the shift sensor connector.
- (h) Reconnect the HV control ECU connector.

NG → **REPAIR OR REPLACE HARNESS OR CONNECTOR**

OK

3 CHECK HYBRID VEHICLE CONTROL ECU (VCX1 AND VCX2 VOLTAGE)

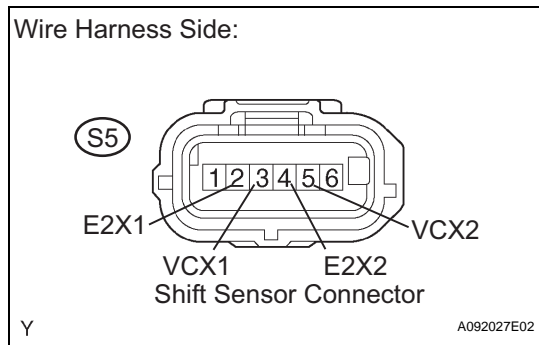

- (a) Disconnect the S5 shift sensor connector.
- (b) Turn the power switch ON (IG).
- (c) Measure the voltage between the terminals of the shift sensor connector.

Standard voltage

Tester Connection	Specified Condition
VCX1 (S5-3) - E2X1 (S5-2)	4.5 to 5.5 V
VCX2 (S5-6) - E2X2 (S5-5)	4.5 to 5.5 V

- (d) Reconnect the shift sensor connector.

OK → **Go to step 7**

NG

REPLACE HYBRID VEHICLE CONTROL ECU

4 READ VALUE OF INTELLIGENT TESTER (SM AND SS SHIFT SENSOR)

- (a) Connect the intelligent tester to the DLC3.
- (b) Turn the power switch ON (IG).
- (c) Turn the intelligent tester ON.
- (d) Enter the following menus: DIAGNOSIS / OBD/MOBD / HV ECU / DATA LIST.
- (e) Read the SM and SS SHIFT SENSOR voltage values.

Result:

Shift Position	SM Shift Sensor	SS Shift Sensor
R, N or D position	3.0 to 4.85 V	3.0 to 4.85 V
Home or B position	0.5 to 2.0 V	0.5 to 2.0 V

OK → **Go to step 7**

HV

NG

5 CHECK HARNESS AND CONNECTOR (HYBRID VEHICLE CONTROL ECU - SELECT SENSOR)

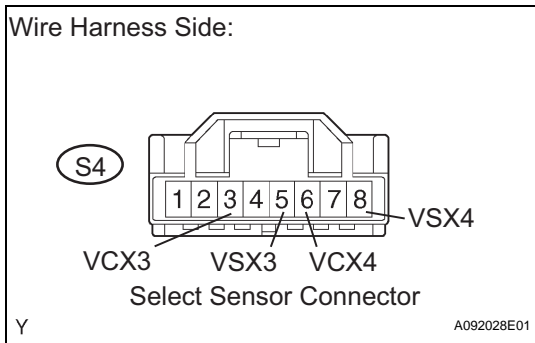
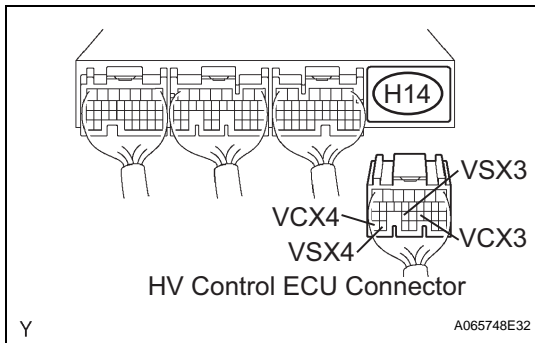

(a) Disconnect the H14 HV control ECU connector.

(b) Disconnect the S4 select sensor connector.

(c) Turn the power switch ON (IG).

(d) Measure the voltage between the terminals of the HV control ECU connector and body ground.

Standard voltage

Tester Connection	Specified Condition
VCS3 (H14-21) - Body ground	Below 1 V
VVSX3 (H14-23) - Body ground	Below 1 V
VCS4 (H14-31) - Body ground	Below 1 V
VSX4 (H14-30) - Body ground	Below 1 V

(e) Turn the power switch OFF.

(f) Measure the resistance between the wire harness side connectors.

Standard resistance (Check for open)

Tester Connection	Specified Condition
VCS3 (H14-21) - VCS3 (S4-3)	Below 1 Ω
VSX3 (H14-23) - VSX3 (S4-5)	Below 1 Ω
VCS4 (H14-31) - VCS4 (S4-6)	Below 1 Ω
VSX4 (H14-30) - VSX4 (S4-8)	Below 1 Ω

Standard resistance (Check for short)

Tester Connection	Specified Condition
VCS3 (H14-21) or VCS3 (S4-3) - Body ground	10 kΩ or higher
VSX3 (H14-23) or VSX3 (S4-5) - Body ground	10 kΩ or higher
VCS4 (H14-31) or VCS4 (S4-6) - Body ground	10 kΩ or higher
VSX4 (H14-30) or VSX4 (S4-8) - Body ground	10 kΩ or higher

(g) Reconnect the select sensor connector.

(h) Reconnect the HV control ECU connector.

NG

REPAIR OR REPLACE HARNESS OR CONNECTOR

HV

OK

6 INSPECT HYBRID VEHICLE CONTROL ECU (VCX3 AND VCX4 VOLTAGE)

Wire Harness Side:

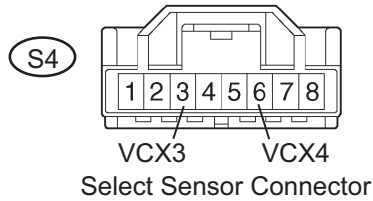

- (a) Disconnect the S4 select sensor connector.
- (b) Turn the power switch ON (IG).
- (c) Measure the voltage between the terminals of the select sensor connector and body ground.

Standard voltage

Tester Connection	Specified Condition
VCX3 (S4-3) - Body ground	9 to 14 V
VCX4 (S4-6) - Body ground	9 to 14 V

- (d) Reconnect the select sensor connector.

NG

REPLACE HYBRID VEHICLE CONTROL ECU

OK

7 REPLACE SELECTOR LEVER

GO

8 READ OUTPUT DTC (DTC P0705 IS NOT OUTPUT AGAIN)

- (a) Connect the intelligent tester to the DLC3.
- (b) Turn the power switch ON (IG).
- (c) Turn the intelligent tester ON.
- (d) Enter the following menus: DIAGNOSIS / OBD/MOBD / HV ECU / DTC INFO / CLEAR CODES.
- (e) Perform a simulation test.
- (f) Enter the following menus: DIAGNOSIS / OBD/MOBD / HV ECU / DTC INFO / CURRENT CODES.
- (g) Read DTCs.

Result:

DTC P0705 is not output again

YES

SYSTEM IS OK

NO

REPLACE HYBRID VEHICLE CONTROL ECU

DTC	P0851-579	Park / Neutral Switch Input Circuit Low
------------	------------------	--

DTC	P0852-580	Park / Neutral Switch Input Circuit High
------------	------------------	---

DESCRIPTION

Instead of having a parking position as one of the positions of the conventional shift lever, a P position switch is provided independently in the upper area of the selector lever. The switch is based on a momentary type operation mode, in which the button does not lock mechanically.

The P position switch contains resistors R1 and R2. When the P position switch is not pressed, the switch provides a combined resistance of R1 and R2; and when the P position switch is pressed, the switch provides only the resistance of R1. The voltage at the P1 terminal of the HV control ECU varies with the changes in the resistance of the switch. The HV control ECU determines the P position switch operation intended by the driver according to this resistance signal.

DTC No.	INF Code	DTC Detection Condition	Trouble Area
P0851	579	GND short in P position switch circuit	<ul style="list-style-type: none"> • Wire harness or connector • P position switch • HV control ECU
P0852	580	Open or +B short in P position switch circuit	<ul style="list-style-type: none"> • Wire harness or connector • P position switch • HV control ECU

WIRING DIAGRAM

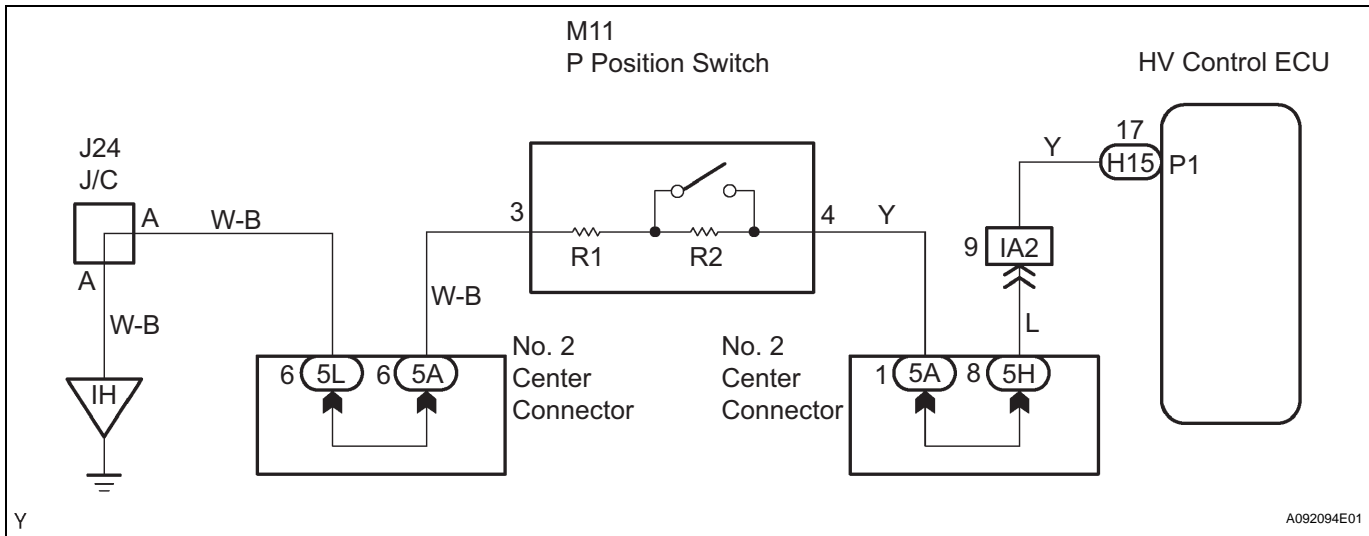

INSPECTION PROCEDURE

1 INSPECT P POSITION SWITCH

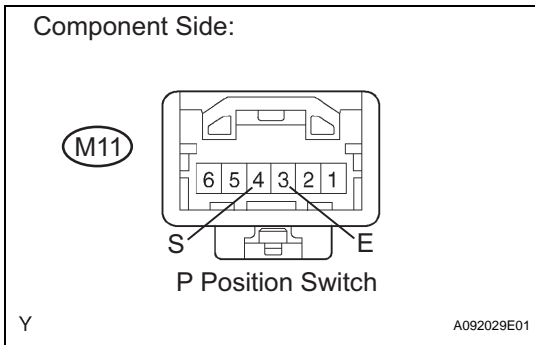

- (a) Remove the P position switch.
- (b) Measure the resistance between the terminals of the P position switch connector.

Standard resistance

Tester Connection	Condition	Specified Condition
S (M11-4) - E (M11-3)	Keep switch pressed	680 Ω
S (M11-4) - E (M11-3)	Release switch	4,580 Ω

- (c) Reinstall the P position switch.

NG → **REPLACE P POSITION SWITCH**

OK

2 CHECK HARNESS AND CONNECTOR (HYBRID VEHICLE CONTROL ECU - P POSITION SWITCH)

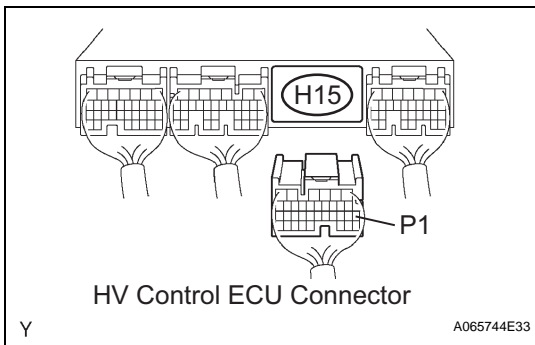

- (a) Disconnect the H15 HV control ECU connector.

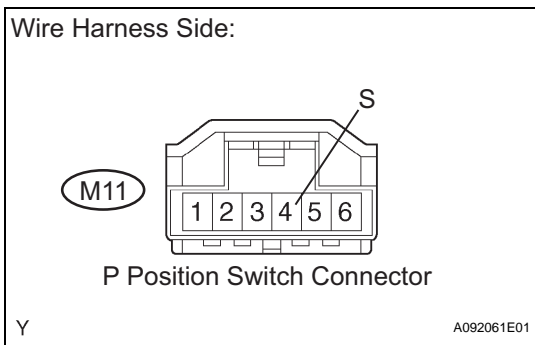

- (b) Disconnect the M11 P position switch connector.
- (c) Turn the power switch ON (IG).
- (d) Measure the voltage between the terminal of the HV control ECU connector and body ground.

Standard voltage

Tester Connection	Specified Condition
P1 (H15-17) - Body ground	Below 1 V

- (e) Turn the power switch OFF.
- (f) Measure the resistance between the wire harness side connectors.

Standard resistance (Check for open)

Tester Connection	Specified Condition
P1 (H15-17) - S (M11-4)	Below 1 Ω

Standard resistance (Check for short)

Tester Connection	Specified Condition
P1 (H15-17) or S (M11-4) - Body ground	10 kΩ or higher

- (g) Reconnect the P position switch connector.
- (h) Reconnect the HV control ECU connector.

HV

NG

REPAIR OR REPLACE HARNESS OR CONNECTOR

OK

3 CHECK HARNESS AND CONNECTOR (P POSITION SWITCH - BODY GROUND)

Wire Harness Side:

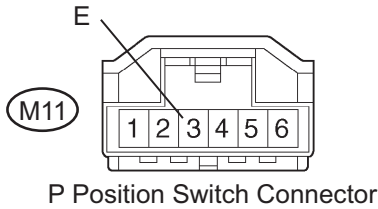

- (a) Disconnect the M11 P position switch connector.
- (b) Measure the resistance between the terminal of the P position switch connector and body ground.

Standard resistance (Check for open)

Tester Connection	Specified Condition
E (M11-3) - Body ground	Below 1 Ω

- (c) Reconnect the P position switch connector.

NG

REPAIR OR REPLACE HARNESS OR CONNECTOR

OK

REPLACE HYBRID VEHICLE CONTROL ECU

DTC	P0A08-264	DC / DC Converter Status Circuit
------------	------------------	---

DESCRIPTION

The HV Control ECU monitors the DC / DC converter circuit status via the NODD terminal. If the ECU detects an internal circuit malfunction in the converter and stops converter operation with its fail-safe function, causing the auxiliary battery voltage to drop below 11 V, the ECU outputs DTC P0A08 (INF 264).

DTC No.	INF Code	DTC Detection Condition	Trouble Area
P0A08	264	All conditions below are detected <ul style="list-style-type: none"> • DC / DC converter internal circuit malfunction is detected • DC / DC converter enters fail-safe mode • Auxiliary battery voltage drops below 11 V 	<ul style="list-style-type: none"> • Auxiliary battery • Fusible link block assembly • Fuse (for 12 V electrical equipment) • Engine room relay block • Inverter cooling hose • Water pump with motor assembly • Cooling fan motor • No. 2 cooling fan motor • Wire harness or connector • Inverter with converter assembly (DC / DC converter)

WIRING DIAGRAM

Refer to DTC P0A09 (INF265) (see page HV-125).

INSPECTION PROCEDURE

1	CHECK FOR DTC
----------	----------------------

- (a) Clear the DTC(s) (see page HV-39).
- (b) Connect the intelligent tester to the DLC3.
- (c) Turn the power switch ON (IG) and turn the intelligent tester ON.
- (d) Read DTC(s).

Result:

Result	Proceed to
One or more of following DTCs is output: P0A94, P0AA1, P0AA4, P0AA6, P0AE0, P0AE6, P0AE7, P0ADB, P0ADF, P3000, P3004, P3110	A
P0A08 is output	B

A
GO TO DIAGNOSTIC TROUBLE CODE CHART

B

2	CHECK CABLE CONNECTION FROM AUXILIARY BATTERY TERMINAL
----------	---

- (a) Turn the power switch OFF.
- (b) Check the auxiliary battery (12 V) cable connections at places listed below:
 - The battery positive and negative terminals are not loose.

- The body ground of the battery negative cable is not loose.
- The FL block nut is not loose.

OK:

They are not loose.

NG **CONNECT OR INSTALL SECURELY**

OK

3 CHECK CONNECTION OF CONNECTORS (FUSIBLE LINK BLOCK ASSEMBLY)

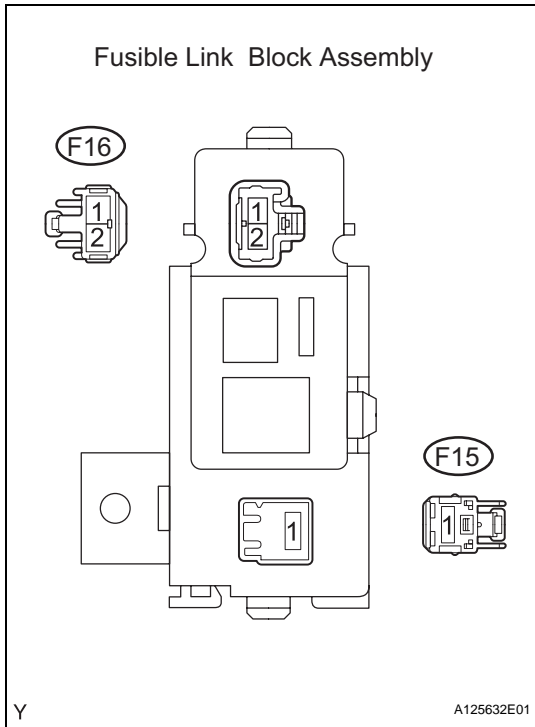

- (a) Check that the F15 and F16 connectors are securely connected to the fusible link block assembly.

OK:

Connectors are connected securely.

OK **Go to step 5**

HV

NG

4 CHECK CONNECTOR (FUSIBLE LINK BLOCK ASSEMBLY)

- (a) Check that the F15 and F16 connector terminals do not have burnout.

OK:

There is no burnout.

NG **REPAIR OR REPLACE CONNECTOR**

OK

5 INSPECT FUSIBLE LINK BLOCK ASSEMBLY

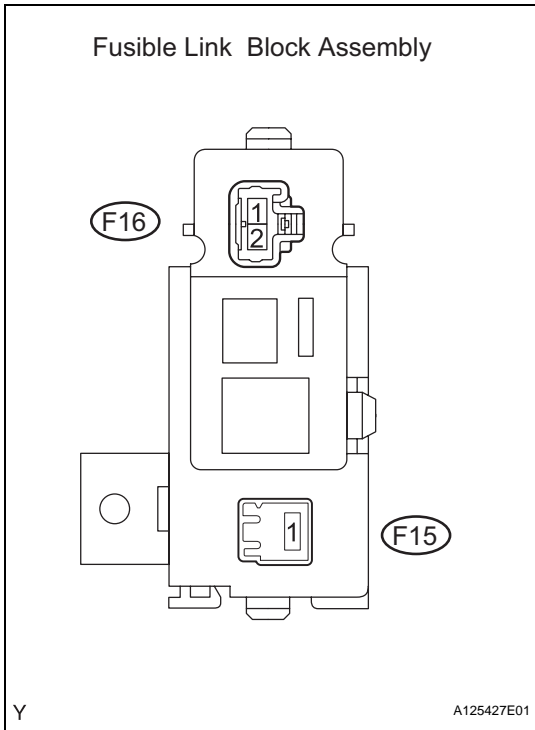

- (a) Measure the resistance between the F15 fusible link block assembly and body ground.

Standard resistance

Tester Connection	Specified Condition
F15-1 Body ground	Below 1 Ω

If the result is not as specified, proceed to NG-A.

- (b) Measure the resistance between the F16 fusible link block assembly and body ground.

Standard resistance

Tester Connection	Specified Condition
F16-1 Body ground	Below 1 Ω
F16-2 Body ground	Below 1 Ω

If the result is not as specified, proceed to NG-B.

NG-A REPAIR OR REPLACE FUSIBLE LINK BLOCK ASSEMBLY

NG-B REPAIR FUSIBLE LINK BLOCK ASSEMBLY AND REPLACE DC / DC FUSE

OK

6 CHECK INSTALLATION CONDITION OF DC / DC FUSE (ENGINE ROOM JUNCTION BLOCK)

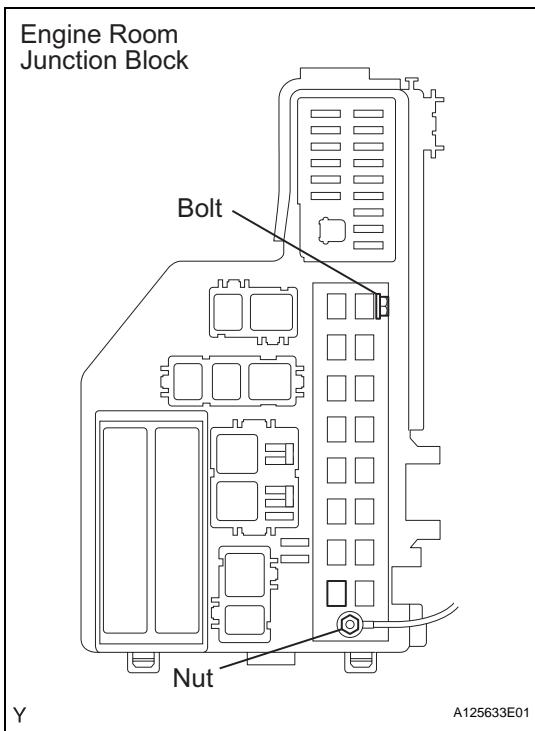

- (a) Check the installation condition of the DC / DC fuse.

OK:

No bolts or nuts are loose.

NG TIGHTEN BOLT OR NUT

OK

7 CHECK FUSIBLE LINK BLOCK ASSEMBLY (100A DC / DC-S)

- (a) Remove the DC / DC-S fuse from the fusible link block assembly.
- (b) Measure the resistance of the fuse.

Standard resistance:**Below 1 Ω**

NG

REPLACE FUSIBLE LINK BLOCK ASSEMBLY

OK

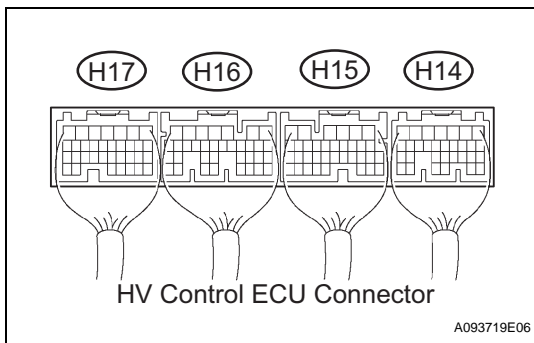
8 CHECK CONNECTION OF CONNECTORS (HV CONTROL ECU)

- (a) Check that the H14, H15, H16 and H17 ECU connectors are securely connected.

OK:**Connectors are connected securely.**

NG

CONNECT SECURELY

OK

9 CHECK CONNECTION OF CONNECTORS (INVERTER WITH CONVERTER ASSEMBLY)**CAUTION:****Inverter with converter assembly:****Be sure to wear insulated gloves.**

- (a) Turn the power switch OFF.
- (b) Remove the service plug grip (see page [HV-1](#)).

CAUTION:**Keep the removed service plug grip in your pocket to prevent other technicians from reconnecting it while you are servicing the vehicle.****NOTICE:****After removing the service plug grip, do not operate the power switch as it may damage the hybrid vehicle control ECU.**

- (c) Leave the vehicle as is for 5 minutes.

HINT:

It takes 5 minutes for the high voltage condenser in the inverter to discharge its electricity.

- (d) Remove the inverter cover (see page [HV-531](#)).

HV

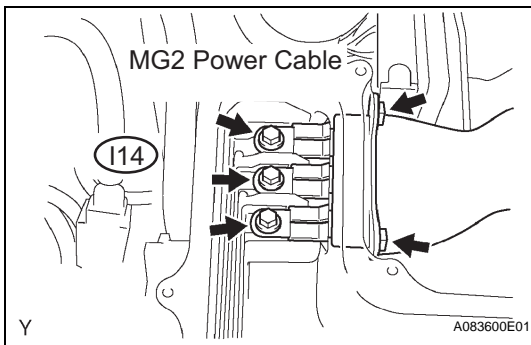

(e) Remove the 5 bolts to disconnect the MG2 power cable.

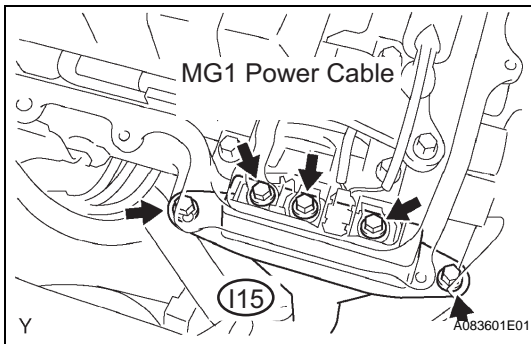

(f) Remove the 5 bolts to disconnect the MG1 power cable.

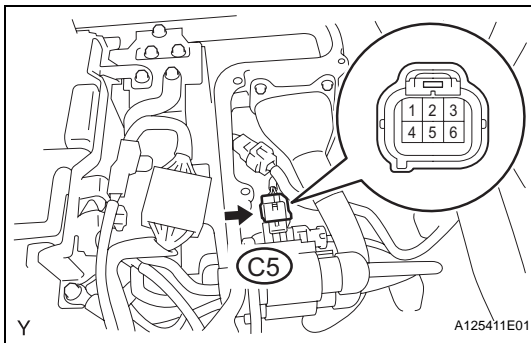

(g) Check the connection condition of the C5 connector.

OK:

Connector has been connected securely.

NG → CONNECT SECURELY

OK

10 CHECK CONNECTION OF CONNECTOR (INVERTER WITH CONVERTER ASSEMBLY)

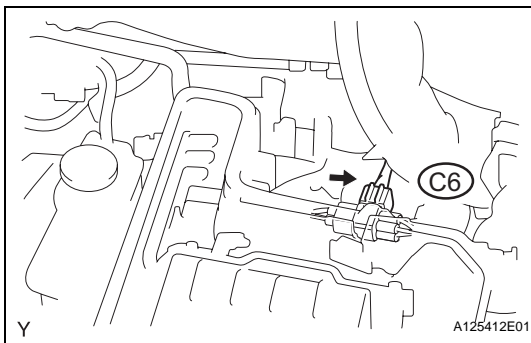

(a) Check that the C6 connector is connected securely.

OK:

Connector is connected securely.

OK → Go to step 12

NG

11 CHECK INVERTER WITH CONVERTER ASSEMBLY

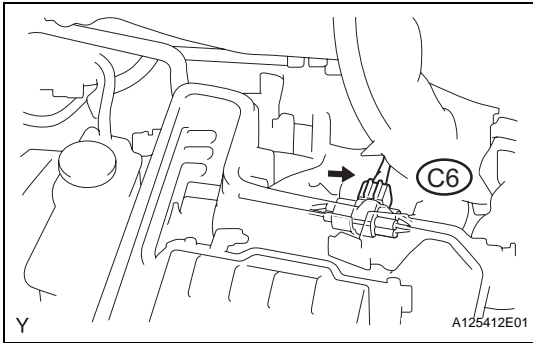

- (a) Disconnect the C6 connector.
- (b) Check that the C6 connector terminal does not have burnout.

OK:

There is no burnout.

NG REPAIR OR REPLACE CONNECTOR

OK

12 CHECK HARNESS AND CONNECTOR (INVERTER WITH CONVERTER ASSEMBLY - BATTERY AND BODY GROUND)

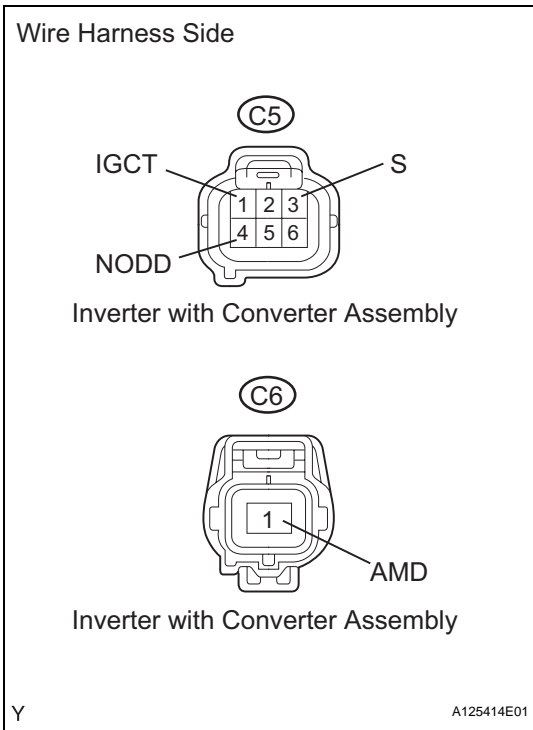

- (a) Disconnect the C5 and C6 converter inverter connectors.
- (b) Turn the power switch ON (IG).
- (c) Measure the voltage of the wire harness side connectors.

Standard voltage

Tester Connection	Condition	Specified Condition
C5-3 (S) - Body ground	Always	Some as 12 V battery voltage
C6-1 (AMD) - Body ground	Always	Some as 12 V battery voltage
C5-1 (IGCT) - Body ground	Power switch ON (IG)	8 to 16 V

- (d) Measure the resistance between the wire harness side connector.

Standard resistance

Tester Connection	Condition	Specified Condition
C5-4 (NODD) - Body ground	IG-OFF	100 to 140 Ω

NG REPAIR OR REPLACE HARNESS OR CONNECTOR

OK

HV

13 CHECK OPERATION OF INVERTER WITH CONVERTER ASSEMBLY

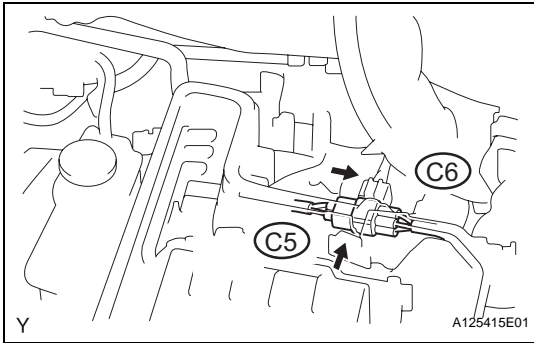

- (a) Connect the C5 and C6 converter inverter connectors.
- (b) Set the electrical tester with the AC/DC 400 A probe to the wire harness of the C6 connector.
- (c) Connect the I14 and I15 connectors (color: orange) to the inverter.
- (d) Install the inverter cover.
- (e) Install the service plug grip.
- (f) Turn the power switch ON (READY).
- (g) Wait 5 minutes.
- (h) Operate the electrical devices as listed below:
 - Set the light control switch to High beam.
 - Set the heater blower fan to HI.
 - Turn on the defogger.
 - Depress the brake pedal.
 - Press all the switches of the window regulator master switch at the same time.
 - Turn the steering wheel to the right or left.
- (i) Measure the amperage and voltage.

Standard amperage

Item	Specified Condition
Output current	40 to 100 A

Standard voltage

Item	Specified Condition
Battery voltage	13 to 15 V

OK → **Go to step 15**

HV

NG

14 INSPECT FUSE

- (a) Remove the EPS-H, HEAD MAIN-H, H-LP LO LH, H-LP LO RH, H-LP HI LH, and H-LP HI RH fuses from the engine room relay block.
- (b) Remove the DEF-H, PWR-H, FR-DOOR, STOP M/HTR, A/C (HTR) fuses from the driver side junction block.
- (c) Measure the resistance of the fuses.

Standard resistance:
Below 1 Ω

NG → **CHECK FOR SHORT IN ALL HARNESS OR CONNECTORS CONNECTED TO FUSE AND REPLACE FUSE**

OK

15 CHECK COOLANT LEVEL OF INVERTER WITH CONVERTER ASSEMBLY

- (a) Check the coolant level in the reservoir tank.

OK:

Coolant level in the reservoir tank is between F and L line.

NG

ADD COOLANT

OK

16 CHECK INVERTER COOLANT HOSE

- (a) Check if the inverter cooling hoses are bent, twisted, damaged or clogged.

OK:

Hoses are not bent, twisted, damaged, or clogged.

NG

REPAIR OR REPLACE HOSE

OK

17 CHECK CONNECTION CONDITION OF WATER PUMP WITH MOTOR CONNECTOR (LOOSENESS AND POOR CONNECTION)

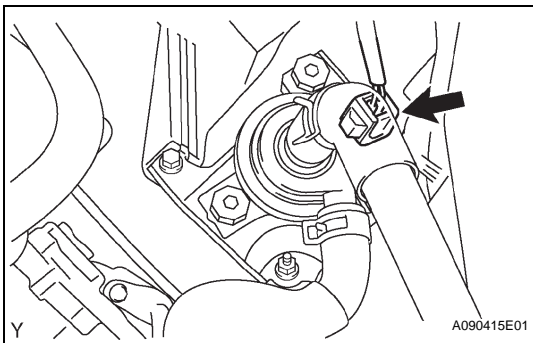

- (a) Check the connection condition of the pump and bracket connector.

OK:

Connector has been connected securely.

NG

CONNECT SECURELY

HV

OK

18 CHECK OPERATION OF WATER PUMP WITH MOTOR ASSEMBLY

- (a) Turn the power switch ON (IG).
- (b) Check the operation of the motor.

OK:

Coolant surface in reservoir tank has waves.

NG

REPLACE WATER PUMP WITH MOTOR ASSEMBLY

OK

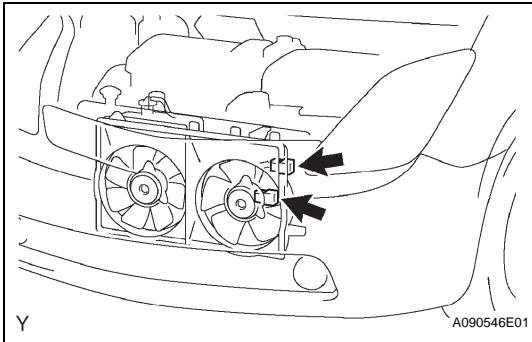
**19 CHECK CONNECTION CONDITION OF COOLING FAN MOTOR CONNECTOR
(LOOSENESS AND POOR CONNECTION)**

(a) Check the connection condition of the fan connectors.

OK:

Connectors have been connected securely.

NG

CONNECT SECURELY

OK

20 INSPECT COOLING FAN MOTOR

(a) Inspect cooling fan motor (see page [CO-5](#)).

NG

REPLACE COOLING FAN MOTOR

OK

REPLACE INVERTER WITH CONVERTER ASSEMBLY

DTC	P0A09-265	DC / DC Converter Status Circuit Low Input
------------	------------------	---

DTC	P0A10-263	DC / DC Converter Status Circuit High Input
------------	------------------	--

DESCRIPTION

The DC / DC converter converts the DC 201.6 V of the HV battery into DC 12 V in order to supply power to the vehicle's lighting, audio and ECU systems. In addition, it charges the auxiliary battery.

A transistor bridge circuit initially converts DC 201.6 V into alternating current, and a transformer lowers its voltage. Then, it is rectified and smoothed (into DC) and converted into DC 12 V.

The DC / DC converter controls the output voltage in order to keep a constant voltage at the terminals of the auxiliary battery.

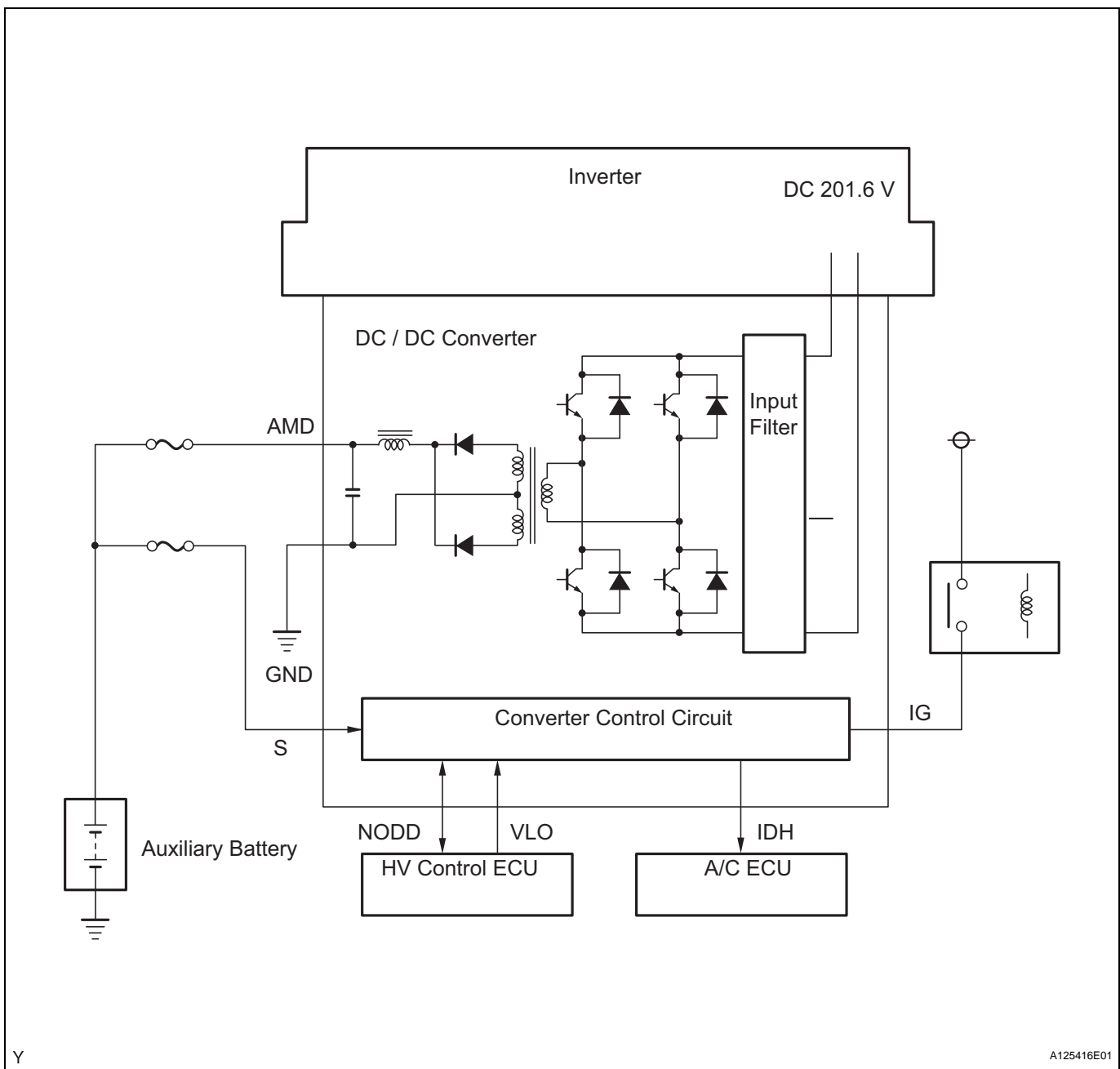

The HV control ECU uses the NODD signal line to transmit a stop command to the DC / DC converter and receive signals indicating the normal or abnormal conditions of the 12 V charging system. If the vehicle is being driven with an inoperative DC / DC converter, the voltage of the auxiliary battery will drop, which will prevent the continued operation of the vehicle. Therefore, the HV control ECU monitors the operation of the DC / DC converter and alerts the driver if it detects a malfunction.

DTC No.	INF Code	DTC Detection Condition	Trouble Area
P0A09	265	Open or GND short in NODD signal circuit of DC / DC converter	<ul style="list-style-type: none"> Wire harness or connector Inverter with converter assembly
P0A10	263	+B short in NODD signal circuit of DC / DC converter	<ul style="list-style-type: none"> Wire harness or connector Inverter with converter assembly

WIRING DIAGRAM

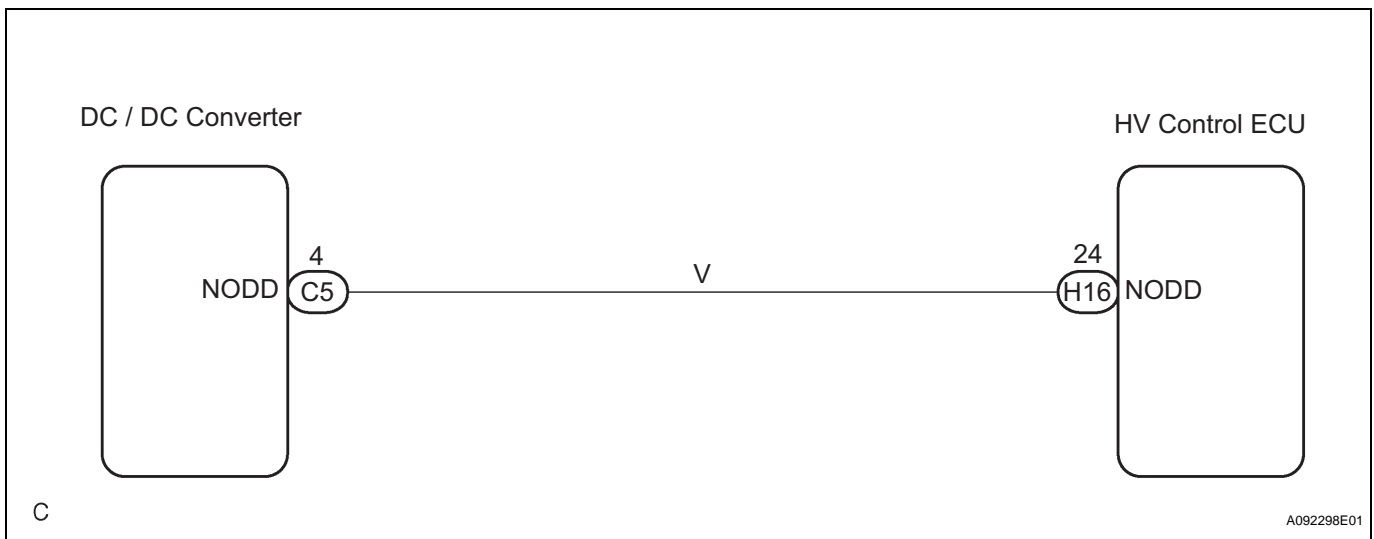

HV

INSPECTION PROCEDURE

1	CHECK HARNESS AND CONNECTOR (HYBRID VEHICLE CONTROL ECU - DC / DC CONVERTER)
----------	---

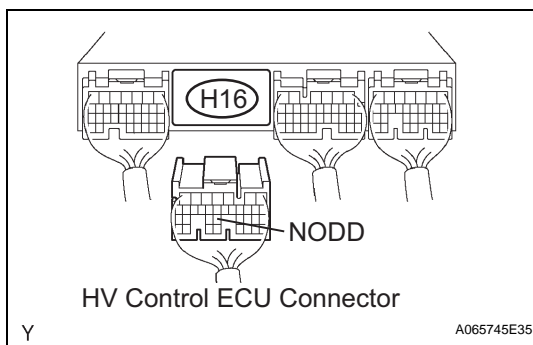

(a) Disconnect the H16 HV control ECU connector.

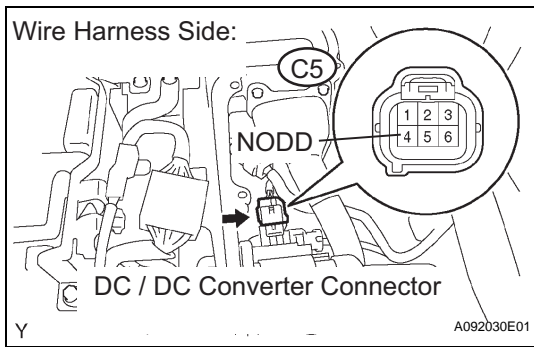

- (b) Disconnect the C5 DC / DC converter connector.
- (c) Turn the power switch ON (IG).
- (d) Measure the voltage between the terminal of the HV control ECU connector and body ground.

Standard voltage

Tester Connection	Specified Condition
NODD (H16-24) - Body ground	Below 1 V

- (e) Turn the power switch OFF.
- (f) Measure the resistance between the wire harness side connectors.

Standard resistance (Check for open)

Tester Connection	Specified Condition
NODD (H16-24) - NODD (C5-4)	Below 1 Ω

Standard resistance (Check for short)

Tester Connection	Specified Condition
NODD (H16-24) or NODD (C5-4) - Body ground	10 kΩ or higher

- (g) Reconnect the DC / DC converter connector.
- (h) Reconnect the HV control ECU connector.

NG → **REPAIR OR REPLACE HARNESS OR CONNECTOR**

OK

REPLACE INVERTER WITH CONVERTER ASSEMBLY

DTC	P0A09-591	DC / DC Converter Status Circuit Low Input
------------	------------------	---

DTC	P0A10-592	DC / DC Converter Status Circuit High Input
------------	------------------	--

DESCRIPTION

See the description of the DC / DC converter (see page HV-124).

The HV control ECU sends the output voltage switch signal to the DC / DC converter via the VLO signal line in order to switch output voltage according to vehicle status.

If the vehicle is being driven with an inoperative DC / DC converter, the voltage of the auxiliary battery will drop, which will prevent the continued operation of the vehicle. Therefore, the HV control ECU monitors the operation of the DC / DC converter and alerts the driver if it detects a malfunction.

DTC No.	INF Code	DTC Detection Condition	Trouble Area
P0A09	591	Open or GND short in VLO signal circuit of DC / DC converter	<ul style="list-style-type: none"> • Wire harness or connector • Inverter with converter assembly
P0A10	592	+B short in VLO signal circuit of DC / DC converter	<ul style="list-style-type: none"> • Wire harness or connector • Inverter with converter assembly

WIRING DIAGRAM

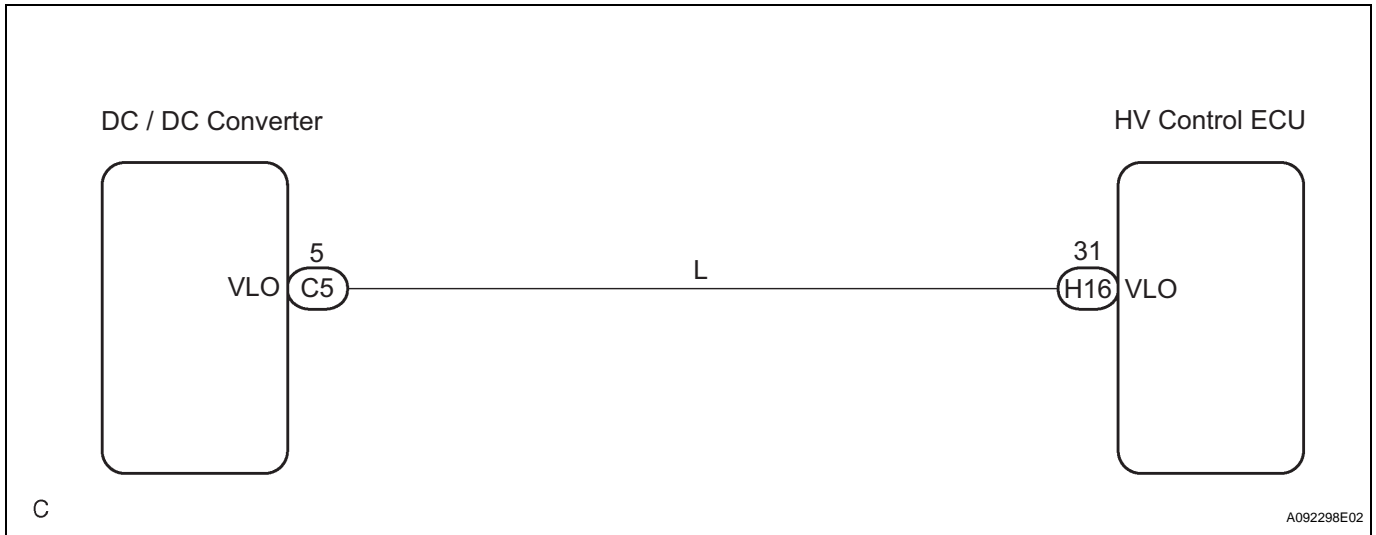

INSPECTION PROCEDURE

1 CHECK HARNESS AND CONNECTOR (HYBRID VEHICLE CONTROL ECU - DC / DC CONVERTER)

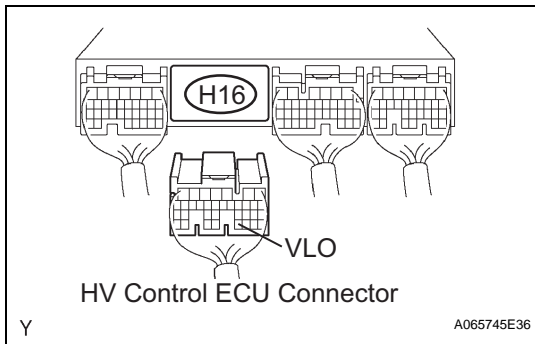

(a) Disconnect the H16 HV control ECU connector.

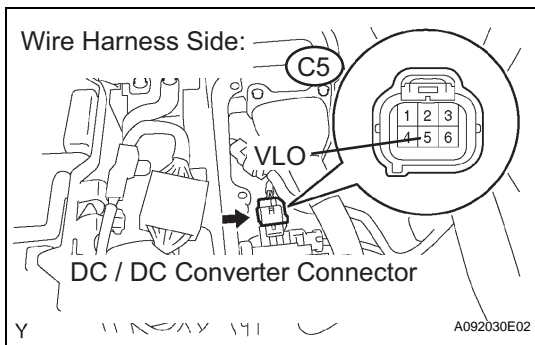

(b) Disconnect the C5 DC / DC converter connector.

(c) Turn the power switch ON (IG).

(d) Measure the voltage between the terminal of the HV control ECU connector and body ground.

Standard voltage

Tester Connection	Specified Condition
VLO (H16-31) - Body ground	Below 1 V

(e) Turn the power switch OFF.

(f) Measure the resistance between the wire harness side connectors.

Standard resistance (Check for open)

Tester Connection	Specified Condition
VLO (H16-31) - VLO (C5-5)	Below 1 Ω

Standard resistance (Check for short)

Tester Connection	Specified Condition
VLO (H16-31) or VLO (C5-5) - Body ground	10 kΩ or higher

(g) Reconnect the DC / DC converter connector.

(h) Reconnect the HV control ECU connector.

NG REPAIR OR REPLACE HARNESS OR CONNECTOR

OK

REPLACE INVERTER WITH CONVERTER ASSEMBLY

HV

DTC	P0A0D-350	High Voltage System Inter-Lock Circuit High
------------	------------------	--

DESCRIPTION

If the HV control ECU detects the operation of the safety devices (removal of the service plug grip and inverter cover) while the vehicle is stopped (vehicle speed below 3 mph [5 km/h]), it will shut down the system main relays. If the safety devices are correctly reinstalled, it will resume the normal operation after the power source is supplied again. If it does not, there is a possibility of an open circuit, so perform the same inspection as the DTC P0A0D (INF 351).

DTC No.	INF Code	DTC Detection Condition	Trouble Area
P0A0D	350	Operating safety devices with vehicle stopped (ILK signal is ON)	<ul style="list-style-type: none"> • Service plug grip installation • Inverter cover installation

INSPECTION PROCEDURE

1	CHECK SERVICE PLUG GRIP INSTALLATION
----------	---

- (a) Check that the service plug grip has been installed properly.

OK:

The service plug grip has been installed properly

NG	CORRECTLY REINSTALL
-----------	----------------------------



2	CHECK INVERTER COVER INSTALLATION
----------	--

- (a) Check that the inverter cover has been installed properly.

OK:

The Inverter cover has been installed properly

NG	CORRECTLY REINSTALL
-----------	----------------------------

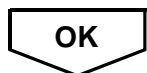

GO TO DTC P0A0D-351

HV

DTC	P0A0D-351	High Voltage System Inter-Lock Circuit High
------------	------------------	--

DESCRIPTION

A short pin for the interlock switch is provided on the service plug grip and the inverter cover. Therefore, the interlock signal line circuit opens when the service plug grip or the inverter cover is removed.

If the HV control ECU detects an open circuit in the interlock signal line while the vehicle is in motion (vehicle speed above 3 mph [5 km/h]), it stores the information (INF) code 351 in its memory and alerts the driver.

While the vehicle is in motion, the HV control ECU will not shut down the high-voltage system even if an open circuit in the interlock system is detected.

DTC No.	INF Code	DTC Detection Condition	Trouble Area
P0A0D	351	Open in interlock signal circuit while vehicle is running	<ul style="list-style-type: none"> Wire harness or connector Battery plug (No. 2 interlock switch) Inverter with converter assembly (No. 1 interlock switch)

WIRING DIAGRAM

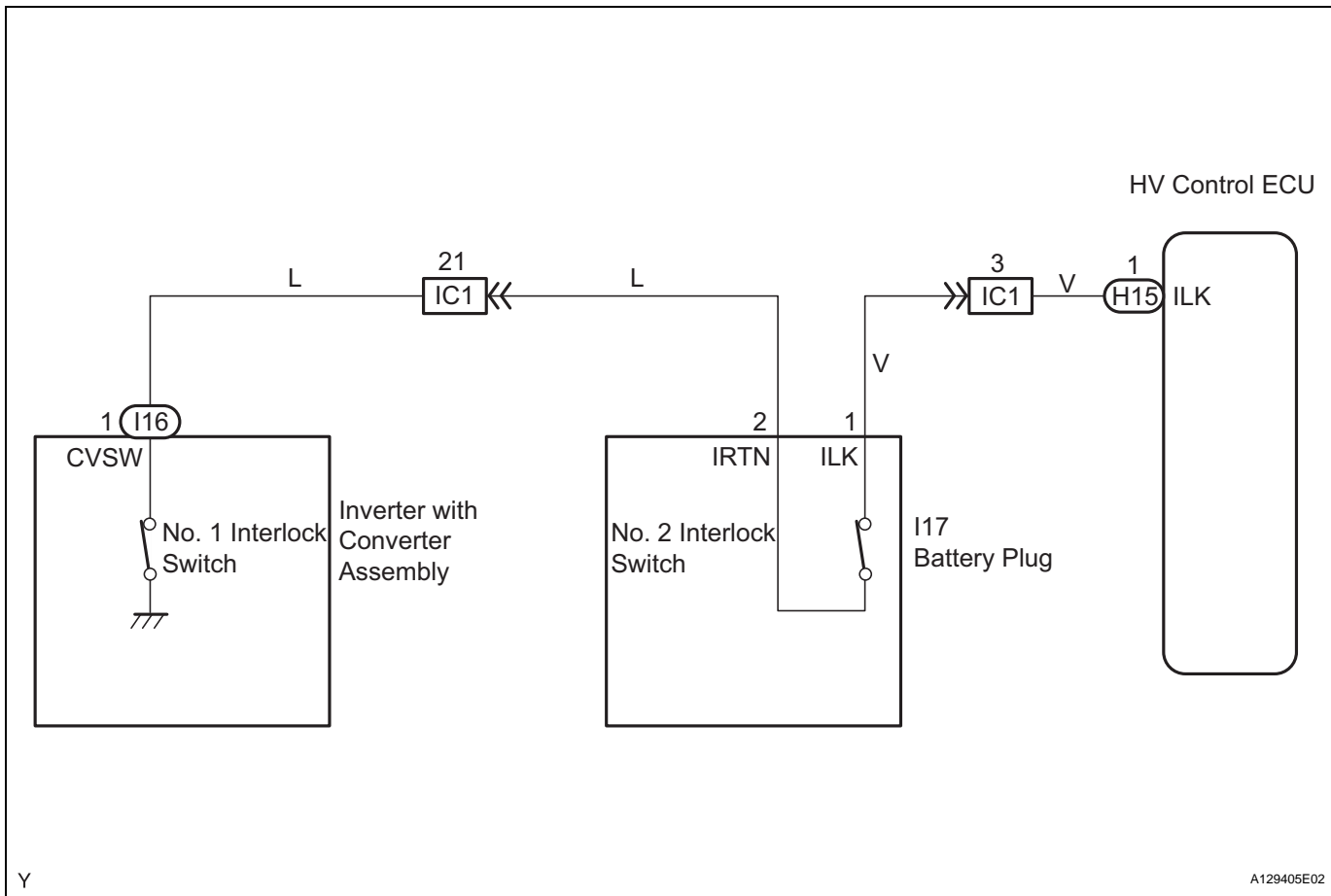

HV

INSPECTION PROCEDURE

CAUTION:

- Before inspecting the high-voltage system, take safety precautions to prevent electrical shocks, such as wearing insulated gloves and removing the service plug grip. After removing the service plug grip, put it in your pocket to prevent other technicians from reconnecting it while you are servicing the high-voltage system.
- After disconnecting the service plug grip, wait for at least 5 minutes before touching any of the high-voltage connectors or terminals.

HINT:

At least 5 minutes are required to discharge the high-voltage condenser inside the inverter.

1 CHECK INVERTER COVER INSTALLATION

- (a) Check that the inverter cover has been installed properly.

Standard:

The inverter cover has been installed properly

NG → **CORRECTLY REINSTALL**

OK

2 CHECK HARNESS AND CONNECTOR (HYBRID VEHICLE CONTROL ECU - NO. 2 INTERLOCK SWITCH)

- (a) Disconnect the H15 HV control ECU connector.

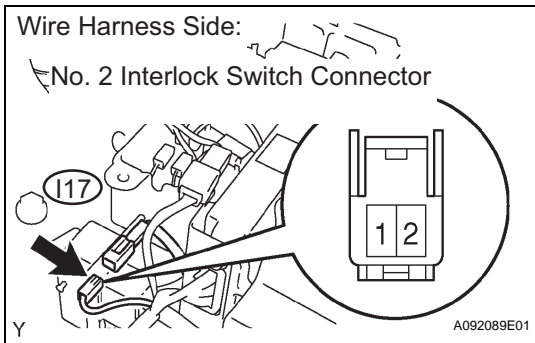
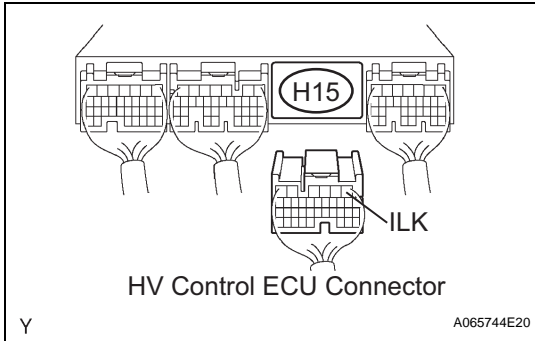

- (b) Disconnect the I17 No. 2 interlock switch connector.
(c) Measure the resistance between the wire harness side connectors.

Standard resistance (Check for open)

Tester Connection	Specified Condition
ILK (H15-1) - ILK (I17-1)	Below 1 Ω

Standard resistance (Check for short)

Tester Connection	Specified Condition
ILK (H15-1) or ILK (I17-1) - Body ground	10 kΩ or higher

- (d) Reconnect the No. 2 interlock switch connector.
(e) Reconnect the HV control ECU connector.

NG → **REPAIR OR REPLACE HARNESS OR CONNECTOR**

OK

HV

3 CHECK HARNESS AND CONNECTOR (NO. 1 INTERLOCK SWITCH - NO. 2 INTERLOCK SWITCH)

CAUTION:

Wear insulated gloves before performing the following operation.

- (a) Turn the power switch OFF.
- (b) Remove the service plug grip (see page [HB-153](#)).

NOTICE:

Turning the power switch ON (READY) with the service plug grip removed could cause malfunction. Therefore, never turn the power switch ON (READY) in this state.

- (c) Remove the inverter cover (see page [HV-531](#)).
- (d) Disconnect the I16 No. 1 interlock switch connector.

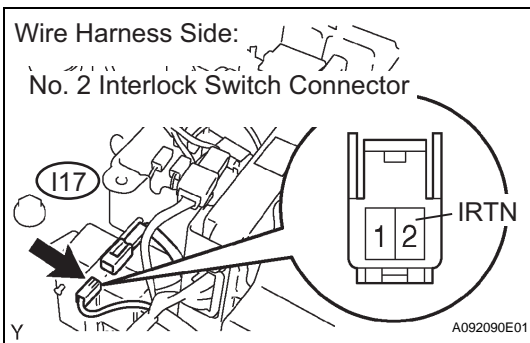
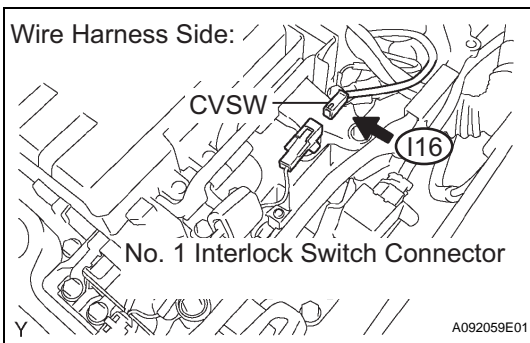

- (e) Disconnect the I17 No. 2 interlock switch connector.
- (f) Measure the resistance between the wire harness side connectors.

Standard resistance (Check for open)

Tester Connection	Specified Condition
CVSW (I16-1) - IRTN (I17-2)	Below 1 Ω

Standard resistance (Check for short)

Tester Connection	Specified Condition
CVSW (I16-1) or IRTN (I17-2) - Body ground	10 kΩ or higher

- (g) Reconnect the No. 1 interlock switch connector.
- (h) Reconnect the No. 2 interlock switch connector.

NG **REPAIR OR REPLACE HARNESS OR CONNECTOR**

OK

4 INSPECT INVERTER WITH CONVERTER ASSEMBLY

CAUTION:

Wear insulated gloves before performing the following operation.

- (a) Check that the service plug grip and inverter cover have been removed.

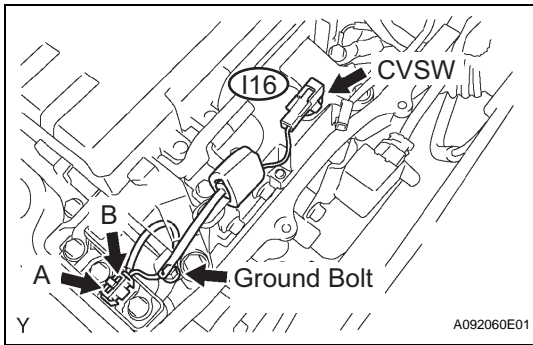

- (b) Disconnect the I16 No. 1 interlock switch connector.
- (c) Check that the ground bolt for the interlock switch is tightened to the specified torque.
- Torque: 8.0 N*m (82 kgf*cm, 71 in.*lbf)**
- (d) Connect terminals A and B as shown in the illustration.
- (e) Measure the resistance between the I16 No. 1 interlock switch connector and body ground.

Standard resistance

Tester Connection	Specified Condition
CVSW (I16-1) - Body ground	Below 1 Ω

- (f) Reconnect the No. 1 interlock switch connector.
- (g) Reinstall the inverter cover (see page [HV-538](#)).
- (h) Reinstall the service plug grip (see page [HB-154](#)).

NG → **REPAIR HARNESS OR CONNECTOR, OR REPLACE INVERTER WITH CONVERTER ASSEMBLY**

OK

REPLACE BATTERY PLUG

DTC	P0A0F-204	Engine Failed to Start
DTC	P0A0F-205	Engine Failed to Start
DTC	P0A0F-533	Engine Failed to Start
DTC	P0A0F-534	Engine Failed to Start

DESCRIPTION

The HV control ECU performs the fail-safe control, when the ECM detects an error which will affect THS control.

DTC No.	INF Code	DTC Detection Condition	Trouble Area
P0A0F	204	Abnormal signal input from ECM (abnormal engine output)	<ul style="list-style-type: none"> ECM SFI system
P0A0F	205	Abnormal signal input from ECM (engine is unable to start)	<ul style="list-style-type: none"> ECM SFI system
P0A0F	533	Abnormal signal input from ECM (abnormal engine output by running out of fuel)	<ul style="list-style-type: none"> ECM SFI system
P0A0F	534	Abnormal signal input from ECM (engine is unable to start by running out of fuel)	<ul style="list-style-type: none"> ECM SFI system

HV

INSPECTION PROCEDURE

1	READ OUTPUT DTC (ENGINE)
----------	---------------------------------

- (a) Connect the intelligent tester to the DLC3.
- (b) Turn the power switch ON (IG).
- (c) Turn the intelligent tester ON.
- (d) Enter the following menus: DIAGNOSIS / ENHANCED OBD II / DTC INFO / CURRENT CODES.
- (e) Read DTCs.

Result:

DTCs are output

NG

GO TO RELEVANT DTC CHART

OK

REPLACE ECM

DTC	P0A0F-238	Engine Failed to Start
------------	------------------	-------------------------------

DESCRIPTION

The HV control ECU detects this DTC and effects fail-safe control if the engine or transaxle gear has seized up, or foreign objects have been caught in either of them.

DTC No.	INF Code	DTC Detection Condition	Trouble Area
P0A0F	238	Engine does not start even though cranking it (transaxle input malfunction [engine system])	<ul style="list-style-type: none"> • Engine assembly • HV transaxle assembly (shaft or gear) • Transmission input damper • Wire harness or connector • HV control ECU

WIRING DIAGRAM

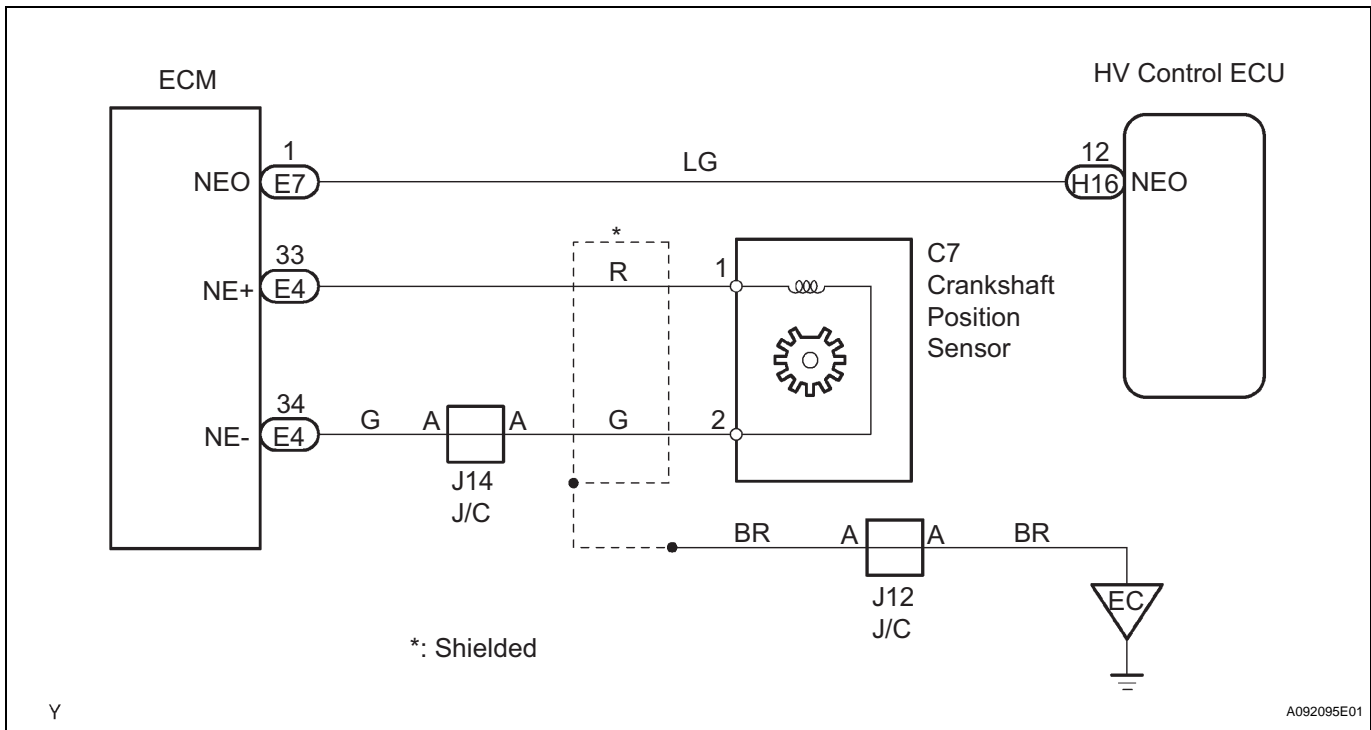

HV

INSPECTION PROCEDURE

1	READ OUTPUT DTC (ENGINE)
----------	---------------------------------

- (a) Connect the intelligent tester to the DLC3.
- (b) Turn the power switch ON (IG).
- (c) Turn the intelligent tester ON.
- (d) Enter the following menus: DIAGNOSIS / ENHANCED OBD II / DTC INFO / CURRENT CODES.
- (e) Read DTCs.

Result:

DTCs are output

YES	GO TO RELEVANT DTC CHART
------------	---------------------------------

NO

2 CHECK CRANKSHAFT PULLEY REVOLUTION

- (a) Turn the power switch OFF.
- (b) Jack up the vehicle.
- (c) Manually turn the crankshaft pulley to check if the crankshaft rotates.

OK:

The crankshaft rotates

NG

Go to step 11

OK

3 CHECK HARNESS AND CONNECTOR (ECM - CRANKSHAFT POSITION SENSOR)

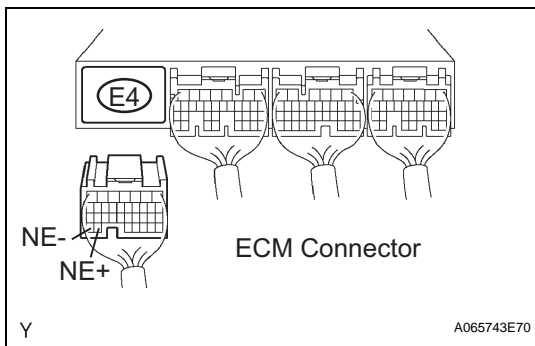

- (a) Disconnect the E4 ECM connector.

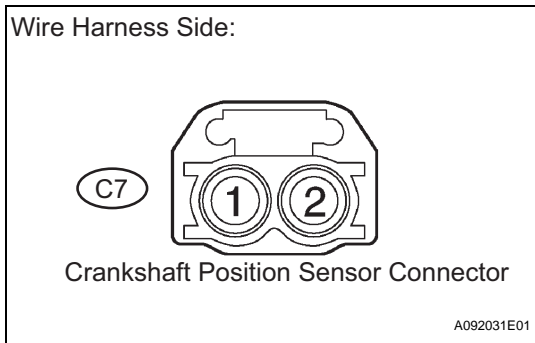

- (b) Disconnect the C7 crankshaft position sensor connector.
- (c) Measure the resistance between the wire harness side connectors.

Standard resistance (Check for open)

Tester Connection	Specified Condition
NE+ (E4-33) - Crankshaft position sensor (C7-1)	Below 1 Ω
NE- (E4-34) - Crankshaft position sensor (C7-2)	Below 1 Ω

Standard resistance (Check for short)

Tester Connection	Specified Condition
NE+ (E4-33) or Crankshaft position sensor (C7-1) - Body ground	10 kΩ or higher
NE- (E4-34) or Crankshaft position sensor (C7-2) - Body ground	10 kΩ or higher

- (d) Reconnect the crankshaft position sensor connector.
- (e) Reconnect the ECM connector.

NG

REPAIR OR REPLACE HARNESS OR CONNECTOR

OK

HV

4 CHECK HARNESS AND CONNECTOR (HYBRID VEHICLE CONTROL ECU - ECM)

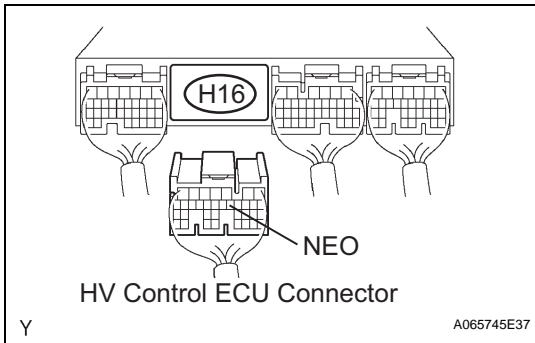

(a) Disconnect the H16 HV control ECU connector.

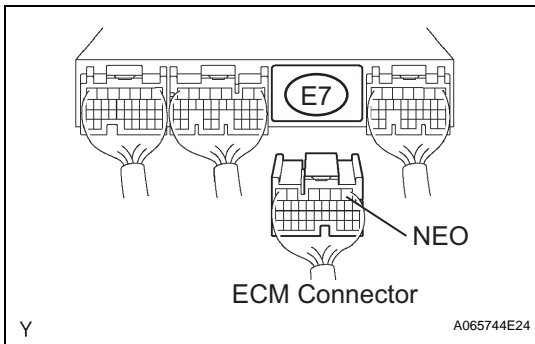

(b) Disconnect the E7 ECM connector.

(c) Measure the resistance between the wire harness side connectors.

Standard resistance (Check for open)

Tester Connection	Specified Condition
NEO (H16-12) - NEO (E7-1)	Below 1 Ω

Standard resistance (Check for short)

Tester Connection	Specified Condition
NEO (H16-12) or NEO (E7-1) -Body ground	10 kΩ or higher

(d) Reconnect the ECM connector.

(e) Reconnect the HV control ECU connector.

NG → **REPAIR OR REPLACE HARNESS OR CONNECTOR**

OK

5 CHECK AND CLEAR DTC (HV ECU)

(a) Connect the intelligent tester to the DLC3.

(b) Turn the power switch ON (IG).

(c) Turn the intelligent tester ON.

(d) Enter the following menus: DIAGNOSIS / OBD/MOBD / HV ECU / DTC INFO / CURRENT CODES.

(e) Check and record the DTCs, the freeze frame data, and the information.

(f) Clear the DTCs of the HV ECU.

GO

6 CHECK READY LIGHT

(a) Connect the intelligent tester to the DLC3.

(b) Turn the power switch ON (IG).

(c) Turn the intelligent tester ON.

(d) Enter the following menus: DIAGNOSIS / OBD/MOBD / HV ECU / DATA LIST.

- (e) Read the MG1 REV and ENGINE SPD values.
- (f) Turn the power switch ON (READY).

OK:

READY light turns ON

HINT:

If the READY light does not turn ON, and the reading on the intelligent tester shows DTC P0A90 (INF 239) (HV transaxle input malfunction [shaft damaged]), or the MG1 turns but the engine does not crank, replace the hybrid vehicle transaxle assembly.

NG

REPLACE HYBRID VEHICLE TRANSAXLE ASSEMBLY

OK

7

CHECK ENGINE REV-UP

- (a) Connect the intelligent tester to the DLC3.
- (b) Turn the power switch ON (IG).
- (c) Turn the intelligent tester ON.
- (d) Enter the following menus: DIAGNOSIS / OBD/MOBD / HV ECU / DATA LIST.
- (e) Read the MG1 REV and ENGINE SPD values.
- (f) With the READY light turned ON, depress the accelerator pedal for 10 seconds while the shift position is in P.

OK:

The engine revs up

HINT:

If the engine does not rev up, and the reading on the intelligent tester shows DTC P0A90 (INF 239) (HV transaxle input malfunction [shaft damaged]), or the MG1 turns but the engine does not crank, replace the hybrid vehicle transaxle assembly.

NG

REPLACE HYBRID VEHICLE TRANSAXLE ASSEMBLY

OK

8

CHECK CREEP MOVEMENT

- (a) Connect the intelligent tester to the DLC3.
- (b) Turn the power switch ON (READY).
- (c) Jack up the vehicle.
- (d) Depress the brake pedal, move the selector lever to the D position, and release the brake pedal.

OK:

The wheels turn (creep movement)

HINT:

If the wheels do not turn, and the reading on the intelligent tester shows DTC P0A90 (INF 602) (HV transaxle output malfunction), replace the hybrid vehicle transaxle assembly.

NG

REPLACE HYBRID VEHICLE TRANSAXLE ASSEMBLY

OK

9 CHECK ENGINE ACCELERATION SPEED

- (a) Connect the intelligent tester to the DLC3.
- (b) While driving at the vehicle speed of more than 6 mph (10 km/h), fully depress the accelerator pedal to raise the engine speed.

OK:

The engine speed increases smoothly

HINT:

If the engine over-revs or the reading on the intelligent tester shows DTC P0A90 (INF 241) (HV transaxle input malfunction [torque limiter slipping]), replace the transmission input damper.

NG

REPLACE TRANSMISSION INPUT DAMPER ASSEMBLY

OK

10 CHECK CAUSE OF INCREASE IN REVOLUTION RESISTANCE

HV

- (a) Investigate what has caused the revolution resistance of the transaxle and engine to become greater.
 - (1) Check the engine lubrication system and transaxle lubrication system.
 - (2) Check the engine coolant and transaxle coolant.
 - (3) Check for any breakdowns in the engine and transaxle.

Result:

There is no fault

NO

REPAIR MALFUNCTIONING PARTS AND COMPONENTS

YES

PERFORM SIMULATION TEST. IF SYMPTOM IS NOT REPRODUCED, REPLACE ENGINE, HV TRANSAXLE AND HV CONTROL ECU

11 CHECK FRONT TIRE REVOLUTION

- (a) Turn the power switch ON (IG).

- (b) Depress the brake pedal, move the selector lever to the N position.
- (c) Jack up the vehicle.
- (d) Manually turn the crankshaft pulley to check if the front tires rotate.

OK:

The front tires rotate

NG 

REPAIR OR REPLACE ENGINE ASSEMBLY

OK

REPAIR OR REPLACE HYBRID VEHICLE TRANSAXLE ASSEMBLY

DTC	P0A1D-134	Hybrid Powertrain Control Module
DTC	P0A1D-135	Hybrid Powertrain Control Module
DTC	P0A1D-570	Hybrid Powertrain Control Module

DESCRIPTION

The HV control ECU performs self-checks to detect an internal operating malfunction in the ECU.

DTC No.	INF Code	DTC Detection Condition	Trouble Area
P0A1D	134 135 570	HV control ECU internal error	<ul style="list-style-type: none"> HV control ECU

MONITOR DESCRIPTION

The HV control ECU performs diagnostic monitoring to verify proper operation of vehicle systems. One of these monitors the rationality of internal analog (signal) to digital conversions.

The HV control ECU monitors the internal A/D (Analog / Digital Converter) value. If there is an A/D malfunction, the HV control ECU will illuminate the MIL and set a DTC.

MONITOR STRATEGY

Related DTCs	P0A1D (INF 134 / 135 / 570): ADC malfunction
Required sensor / components	Hybrid vehicle control ECU
Frequency of operation	Continuous
Duration	TOYOTA's intellectual property
MIL operation	1 driving cycle
Sequence of operation	None

HV

TYPICAL ENABLING CONDITIONS

The monitor will run whenever the following DTCs are not present	TOYOTA's intellectual property
Other conditions belong to TOYOTA's intellectual property	-

TYPICAL MALFUNCTION THRESHOLDS

Hybrid vehicle control ECU	Internal error
----------------------------	----------------

COMPONENT OPERATING RANGE

Hybrid vehicle control ECU	DTC P0A1D (INF 134 / 135 / 570) is not detected
----------------------------	---

INSPECTION PROCEDURE

If any of the above information (INF) codes are present, replace the HV control ECU.

1**REPLACE HYBRID VEHICLE CONTROL ECU**

- (a) Replace the hybrid vehicle control ECU (see page [HV-543](#)).

NEXT**COMPLETED**

DTC	P0A1D- 139	Hybrid Powertrain Control Module
------------	-----------------------	---

DESCRIPTION

The HV control ECU performs self-checks to detect an internal operating malfunction in the ECU.

DTC No.	INF Code	DTC Detection Condition	Trouble Area
P0A1D	139	HV control ECU internal error	• HV control ECU

MONITOR DESCRIPTION

The HV control ECU performs diagnostic monitoring to verify proper operation of vehicle systems. One of these monitors checks the inside of the HV control ECU for a bad integrated circuit which actuates a relay. If the HV control ECU detects a malfunction, it will illuminate the MIL and set a DTC.

MONITOR STRATEGY

Related DTCs	P0A1D (INF 139): IG malfunction
Required sensor / components	Hybrid vehicle control ECU
Frequency of operation	Continuous
Duration	TOYOTA's intellectual property
MIL operation	1 driving cycle
Sequence of operation	None

TYPICAL ENABLING CONDITIONS

The monitor will run whenever the following DTCs are not present	TOYOTA's intellectual property
Other conditions belong to TOYOTA's intellectual property	-

TYPICAL MALFUNCTION THRESHOLDS

Hybrid vehicle control ECU	Internal error
----------------------------	----------------

COMPONENT OPERATING RANGE

Hybrid vehicle control ECU	DTC P0A1D (INF 139) is not detected
----------------------------	-------------------------------------

INSPECTION PROCEDURE

If the above information (INF) code is present, replace the HV control ECU.

1	REPLACE HYBRID VEHICLE CONTROL ECU
----------	---

- (a) Replace the hybrid vehicle control ECU (see page [HV-543](#)).

NEXT

COMPLETED

HV

DTC	P0A1D- 140	Hybrid Powertrain Control Module
------------	-----------------------	---

DESCRIPTION

The HV control ECU performs self-checks to detect an internal operating malfunction in the ECU.

DTC No.	INF Code	DTC Detection Condition	Trouble Area
P0A1D	140	HV control ECU internal error	• HV control ECU

MONITOR DESCRIPTION

The HV control ECU performs many diagnostic tests to verify proper operation of internal ECU systems. One of these tests checks for errors after a memory read / write diagnostic test.

If the HV control ECU detects this malfunction inside of the ECU, it will illuminate the MIL and set a DTC.

MONITOR STRATEGY

Related DTCs	P0A1D (INF 140): RAM destruction
Required sensor / components	Hybrid vehicle control ECU
Frequency of operation	Continuous
Duration	TOYOTA's intellectual property
MIL operation	1 driving cycle
Sequence of operation	None

TYPICAL ENABLING CONDITIONS

The monitor will run whenever the following DTCs are not present	TOYOTA's intellectual property
Other conditions belong to TOYOTA's intellectual property	-

HV TYPICAL MALFUNCTION THRESHOLDS

All RAM area	Read / write check error
--------------	--------------------------

COMPONENT OPERATING RANGE

Hybrid vehicle control ECU	DTC P0A1D (INF 140) is not detected
----------------------------	-------------------------------------

INSPECTION PROCEDURE

If the above information (INF) code is present, replace the HV control ECU.

1	REPLACE HYBRID VEHICLE CONTROL ECU
----------	---

- (a) Replace the hybrid vehicle control ECU (see page [HV-543](#)).



COMPLETED

DTC	P0A1D- 141	Hybrid Powertrain Control Module
------------	-----------------------	---

DESCRIPTION

The HV control ECU performs self-checks to detect an internal operating malfunction in the ECU.

DTC No.	INF Code	DTC Detection Condition	Trouble Area
P0A1D	141	HV control ECU internal error	• HV control ECU

MONITOR DESCRIPTION

The HV control ECU performs many diagnostic tests to verify proper operation of internal ECU systems. One of these tests checks for errors in the ROM (Read Only Memory) circuits of the HV control ECU. If the HV control ECU detects this malfunction inside of the ECU, it will illuminate the MIL and set a DTC.

MONITOR STRATEGY

Related DTCs	P0A1D (INF 141): ROM destruction
Required sensor / components	Hybrid vehicle control ECU
Frequency of operation	Continuous
Duration	TOYOTA's intellectual property
MIL operation	1 driving cycle
Sequence of operation	None

TYPICAL ENABLING CONDITIONS

The monitor will run whenever the following DTCs are not present	TOYOTA's intellectual property
Other conditions belong to TOYOTA's intellectual property	-

TYPICAL MALFUNCTION THRESHOLDS

Hybrid vehicle control ECU	Internal error
----------------------------	----------------

COMPONENT OPERATING RANGE

Hybrid vehicle control ECU	DTC P0A1D (INF 141) is not detected
----------------------------	-------------------------------------

INSPECTION PROCEDURE

If the above information (INF) code is present, replace the HV control ECU.

1	REPLACE HYBRID VEHICLE CONTROL ECU
----------	---

- (a) Replace the hybrid vehicle control ECU (see page [HV-543](#)).

NEXT

COMPLETED

DTC	P0A1D-142	Hybrid Powertrain Control Module
------------	------------------	---

DESCRIPTION

When the ST turned ON in the ignition switch on the previous model, the ignition switch transmitted the ST signal to the HV control ECU.

The new Prius has adopted a push button start system. When the driver pushes on the power switch while depressing the brake pedal, the power source control ECU transmits the ST signal to the HV control ECU.

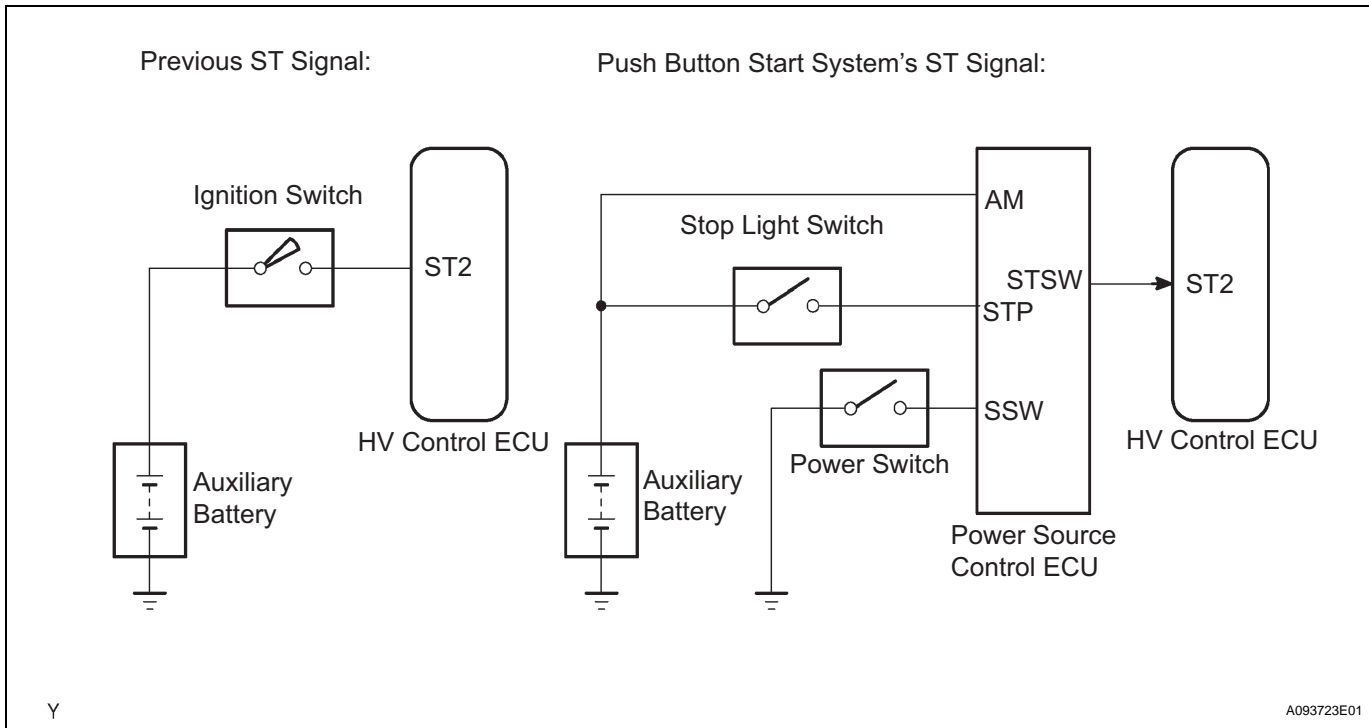

HV

The HV control ECU monitors the ST signal to detect malfunction. If the ST signal is shorted to the +B power supply, the ST will be constantly ON, which will cause the HV system to start by merely turning the power switch ON (IG). The HV control ECU monitors the ST signal to prevent this from occurring.

DTC No.	INF Code	DTC Detection Condition	Trouble Area
P0A1D	142	ST signal of HV control ECU is ON with power switch OFF	<ul style="list-style-type: none"> Wire harness or connector Power source control ECU

MONITOR DESCRIPTION

The HV control ECU monitors an ST signal input from the power source control ECU. If the ST signal is shorted to the +B power supply, the HV control ECU interprets this as the ST signal error, and then illuminates the MIL and sets a DTC.

MONITOR STRATEGY

Related DTCs	P0A1D (INF142): ST malfunction
Required sensor / components	Power source control ECU
Frequency of operation	Continuous
Duration	TOYOTA's intellectual property
MIL operation	1 driving cycle
Sequence of operation	None

TYPICAL ENABLING CONDITIONS

The monitor will run whenever the following DTCs are not present	TOYOTA's intellectual property
Other conditions belong to TOYOTA's intellectual property	-

TYPICAL MALFUNCTION THRESHOLDS

ST signal	ON
-----------	----

COMPONENT OPERATING RANGE

ST signal	OFF (when the power switch OFF)
-----------	---------------------------------

WIRING DIAGRAM

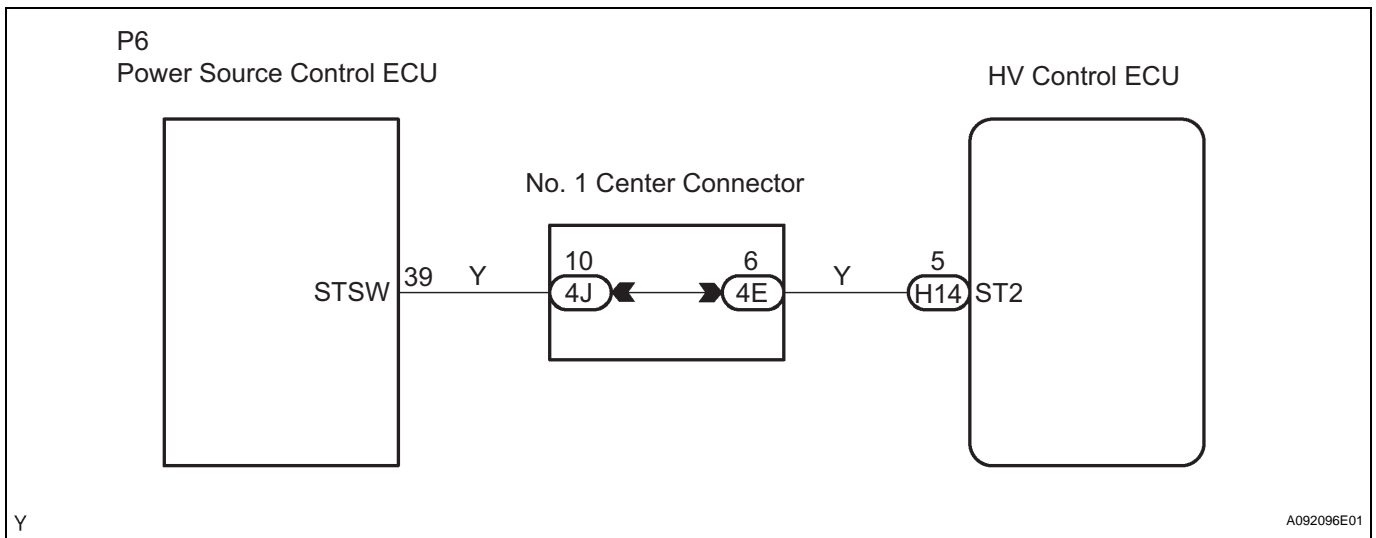

HV

INSPECTION PROCEDURE

1 INSPECT HYBRID VEHICLE CONTROL ECU (ST2 VOLTAGE)

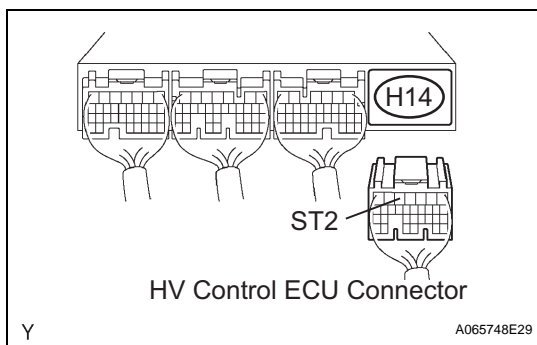

- (a) Disconnect the H14 HV control ECU connector.
- (b) Measure the voltage between the terminal of the HV control ECU connector and body ground with the power switch turned OFF.
Standard voltage

Tester Connection	Specified Condition
ST2 (H14-5) - Body ground	Below 1 V

- (c) Reconnect the HV control ECU connector.

OK → CHECK FOR INTERMITTENT PROBLEMS

NG

2 CHECK HARNESS AND CONNECTOR (HYBRID VEHICLE CONTROL ECU - POWER SOURCE CONTROL ECU)

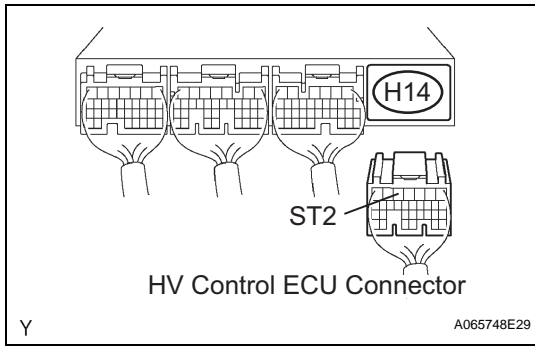

(a) Disconnect the H14 HV control ECU connector.

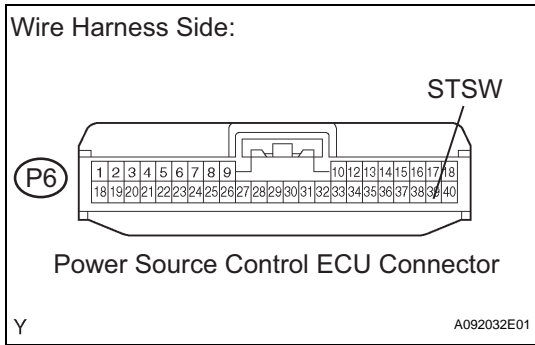

(b) Disconnect the P6 power source control ECU connector.
 (c) Measure the voltage between the terminal of the HV control ECU connector or power source control ECU and body ground with the power switch turned OFF.
Standard voltage

Tester Connection	Specified Condition
ST2 (H14-5) or STSW (P6-39) - Body ground	Below 1 V

(d) Reconnect the power source control ECU connector.
 (e) Reconnect the HV control ECU connector.

NG **REPAIR OR REPLACE HARNESS OR CONNECTOR**

OK

REPLACE POWER SOURCE CONTROL ECU

HV

DTC	P0A1D-143	Hybrid Powertrain Control Module
------------	------------------	---

DESCRIPTION

The HV control ECU performs self-checks to detect an internal operating malfunction in the ECU.

DTC No.	INF Code	DTC Detection Condition	Trouble Area
P0A1D	143	HV control ECU internal error	• HV control ECU

MONITOR DESCRIPTION

The HV control ECU performs diagnostic monitoring to verify proper operation of internal ECU systems. One of these monitors compares read and write values at the inside of the HV control ECU memory, which have been indicated by the transponder key or the electronic key. If those two values are inconsistent with each other, the HV control ECU interprets this as an ECU memory failure of the HV control ECU. The HV control ECU illuminates the MIL and sets a DTC.

MONITOR STRATEGY

Related DTCs	P0A1D (INF 143): EEPROM malfunction
Required sensor / components	Hybrid vehicle control ECU
Frequency of operation	Continuous
Duration	TOYOTA's intellectual property
MIL operation	1 driving cycle
Sequence of operation	None

TYPICAL ENABLING CONDITIONS

The monitor will run whenever the following DTCs are not present	TOYOTA's intellectual property
Other conditions belong to TOYOTA's intellectual property	-

HV**TYPICAL MALFUNCTION THRESHOLDS**

Immobilizer and electronic key area on the EEPROM	Read / write check error
---	--------------------------

COMPONENT OPERATING RANGE

Hybrid vehicle control ECU	DTC P0A1D (INF 143) is not detected
----------------------------	-------------------------------------

INSPECTION PROCEDURE

If the above information (INF) code is present, replace the HV control ECU.

1	REPLACE HYBRID VEHICLE CONTROL ECU
----------	---

- (a) Replace the hybrid vehicle control ECU (see page [HV-543](#)).

NEXT

COMPLETED

DTC	P0A1D-144	Hybrid Powertrain Control Module
------------	------------------	---

DTC	P0A1D-145	Hybrid Powertrain Control Module
------------	------------------	---

DESCRIPTION

The HV control ECU performs self-checks to detect an internal operating malfunction in the ECU.

DTC No.	INF Code	DTC Detection Condition	Trouble Area
P0A1D	144 145	HV control ECU internal error	<ul style="list-style-type: none"> HV control ECU

MONITOR DESCRIPTION

The HV control ECU performs many diagnostic tests to verify proper operation of internal ECU systems. In one of these diagnostics, the HV control ECU performs a self-test.

If the HV control ECU detects an internal problem during this self-test, it will conclude that there is an internal malfunction. The HV control ECU will illuminate the MIL and set a DTC.

MONITOR STRATEGY

Related DTCs	P0A1D (INF 144 / 145): Primary check malfunction
Required sensor / components	Hybrid vehicle control ECU
Frequency of operation	Continuous
Duration	TOYOTA's intellectual property
MIL operation	1 driving cycle
Sequence of operation	None

HV

TYPICAL ENABLING CONDITIONS

The monitor will run whenever the following DTCs are not present	TOYOTA's intellectual property
Other conditions belong to TOYOTA's intellectual property	-

TYPICAL MALFUNCTION THRESHOLDS

Either of the following conditions 1 or 2 is met:	-
1. Reset signal from engine CPU	Not found
2. Communication time between internal ECUs	Time out

COMPONENT OPERATING RANGE

Hybrid vehicle control ECU	DTC P0A1D (INF 144 / 145) is not detected
----------------------------	---

INSPECTION PROCEDURE

If any of the above information (INF) codes are present, replace the HV control ECU.

1 REPLACE HYBRID VEHICLE CONTROL ECU

- (a) Replace the hybrid vehicle control ECU (see page [HV-543](#)).

NEXT**COMPLETED**

DTC	P0A1D-148	Hybrid Powertrain Control Module
DTC	P0A1D-149	Hybrid Powertrain Control Module

DESCRIPTION

The HV control ECU performs self-checks to detect an internal operating malfunction in the ECU.

DTC No.	INF Code	DTC Detection Condition	Trouble Area
P0A1D	148 149	HV control ECU internal error	<ul style="list-style-type: none"> HV control ECU

MONITOR DESCRIPTION

The HV control ECU performs many diagnostic tests to verify proper operation of internal ECU systems. In one of these diagnostics, the HV control ECU performs a self-test.

If the HV control ECU detects an internal problem during this self-test, it will conclude that there is an internal malfunction. The HV control ECU will illuminate the MIL and set a DTC.

MONITOR STRATEGY

Related DTCs	P0A1D (INF 148 / 149): HV CPU malfunction
Required sensor / components	Hybrid vehicle control ECU
Frequency of operation	Continuous
Duration	TOYOTA's intellectual property
MIL operation	1 driving cycle
Sequence of operation	None

HV

TYPICAL ENABLING CONDITIONS

The monitor will run whenever the following DTCs are not present	TOYOTA's intellectual property
Other conditions belong to TOYOTA's intellectual property	-

TYPICAL MALFUNCTION THRESHOLDS

Hybrid vehicle control ECU	Internal error
----------------------------	----------------

COMPONENT OPERATING RANGE

Hybrid vehicle control ECU	DTC P0A1D (INF 148 / 149) is not detected
----------------------------	---

INSPECTION PROCEDURE

If any of the above information (INF) codes are present, replace the HV control ECU.

1	REPLACE HYBRID VEHICLE CONTROL ECU
----------	---

- (a) Replace the hybrid vehicle control ECU (see page [HV-543](#)).

NEXT

COMPLETED

DTC	P0A1D-150	Hybrid Powertrain Control Module
DTC	P0A1D-151	Hybrid Powertrain Control Module
DTC	P0A1D-152	Hybrid Powertrain Control Module
DTC	P0A1D-155	Hybrid Powertrain Control Module
DTC	P0A1D-156	Hybrid Powertrain Control Module
DTC	P0A1D-158	Hybrid Powertrain Control Module
DTC	P0A1D-564	Hybrid Powertrain Control Module

DESCRIPTION

The HV control ECU performs self-checks to detect an internal operating malfunction in the ECU.

HV

DTC No.	INF Code	DTC Detection Condition	Trouble Area
P0A1D	150 151 152 155 156 158 564	HV control ECU internal error	<ul style="list-style-type: none"> HV control ECU

MONITOR DESCRIPTION

The HV control ECU performs many diagnostic tests to verify proper operation of internal and external ECU systems. In one of these diagnostics, the HV control ECU checks the result of the generator CPU self-test. If the HV control ECU detects a "Fail" from the generator CPU self-test, it will conclude that there is an internal malfunction in the generator CPU. The HV control ECU will illuminate the MIL and set a DTC.

MONITOR STRATEGY

Related DTCs	P0A1D (INF 150 / 151 / 152 / 155 / 156 / 158 / 564): Generator CPU malfunction
Required sensor / components	Hybrid vehicle control ECU
Frequency of operation	Continuous
Duration	TOYOTA's intellectual property
MIL operation	1 driving cycle
Sequence of operation	None

TYPICAL ENABLING CONDITIONS

The monitor will run whenever the following DTCs are not present	TOYOTA's intellectual property
Other conditions belong to TOYOTA's intellectual property	-

TYPICAL MALFUNCTION THRESHOLDS

Hybrid vehicle control ECU	Internal error
----------------------------	----------------

COMPONENT OPERATING RANGE

Hybrid vehicle control ECU	DTC P0A1D (INF 150 / 151 / 152 / 155 / 156 / 158 / 564) is not detected
----------------------------	---

INSPECTION PROCEDURE

If any of the above information (INF) codes are present, replace the HV control ECU.

1	REPLACE HYBRID VEHICLE CONTROL ECU
----------	---

- (a) Replace the hybrid vehicle control ECU (see page [HV-543](#)).

NEXT

COMPLETED

DTC	P0A1D-159	Hybrid Powertrain Control Module
DTC	P0A1D-160	Hybrid Powertrain Control Module

DESCRIPTION

The HV control ECU performs self-checks to detect an internal operating malfunction in the ECU.

DTC No.	INF Code	DTC Detection Condition	Trouble Area
P0A1D	159 160	HV control ECU internal error	<ul style="list-style-type: none"> HV control ECU

MONITOR DESCRIPTION

The HV control ECU performs many diagnostic tests to verify proper operation of internal and external ECU systems. In one of these monitors, the HV control ECU checks the motor main CPU serial communication link.

If the HV control ECU detects a failure, it will conclude that there is an internal malfunction involving the HV control ECU to motor main CPU communication link. The HV control ECU will illuminate the MIL and set a DTC.

MONITOR STRATEGY

Related DTCs	P0A1D (INF 159 / 160): Motor CPU serial communication error
Required sensor / components	Hybrid vehicle control ECU
Frequency of operation	Continuous
Duration	TOYOTA's intellectual property
MIL operation	1 driving cycle
Sequence of operation	None

TYPICAL ENABLING CONDITIONS

The monitor will run whenever the following DTCs are not present	TOYOTA's intellectual property
Other conditions belong to TOYOTA's intellectual property	-

TYPICAL MALFUNCTION THRESHOLDS

Hybrid vehicle control ECU	Internal error
----------------------------	----------------

COMPONENT OPERATING RANGE

Hybrid vehicle control ECU	DTC P0A1D (INF 159 / 160) is not detected
----------------------------	---

INSPECTION PROCEDURE

If any of the above information (INF) codes is present, replace the HV control ECU.

1 REPLACE HYBRID VEHICLE CONTROL ECU

- (a) Replace the hybrid vehicle control ECU (see page [HV-543](#)).

NEXT**COMPLETED**

DTC	P0A1D-163	Hybrid Powertrain Control Module
DTC	P0A1D-164	Hybrid Powertrain Control Module
DTC	P0A1D-511	Hybrid Powertrain Control Module
DTC	P0A1D-512	Hybrid Powertrain Control Module

DESCRIPTION

The HV control ECU performs self-checks to detect an internal operating malfunction in the ECU.

DTC No.	INF Code	DTC Detection Condition	Trouble Area
P0A1D	163 164 511 512	HV control ECU internal error	<ul style="list-style-type: none"> HV control ECU

MONITOR DESCRIPTION

The HV control ECU performs diagnostic monitoring to verify proper operation of internal and external ECU systems. In one of these monitors, the HV control ECU monitors the power supply for the motor main CPU.

If the HV control ECU detects a failure in the power supply for the motor main CPU, it will illuminate the MIL and set a DTC.

HV

MONITOR STRATEGY

Related DTCs	P0A1D (INF 163 / 164 / 511 / 512): Motor ECU power malfunction
Required sensor / components	Hybrid vehicle control ECU
Frequency of operation	Continuous
Duration	TOYOTA's intellectual property
MIL operation	1 driving cycle
Sequence of operation	None

TYPICAL ENABLING CONDITIONS

The monitor will run whenever the following DTCs are not present	TOYOTA's intellectual property
Other conditions belong to TOYOTA's intellectual property	-

TYPICAL MALFUNCTION THRESHOLDS

Hybrid vehicle control ECU	Internal error
----------------------------	----------------

COMPONENT OPERATING RANGE

Hybrid vehicle control ECU	DTC P0A1D (INF 163 / 164 / 511 / 512) is not detected
----------------------------	---

INSPECTION PROCEDURE

If any of the above information (INF) codes are present, replace the HV control ECU.

1**REPLACE HYBRID VEHICLE CONTROL ECU**

- (a) Replace the hybrid vehicle control ECU (see page [HV-543](#)).

NEXT**COMPLETED**

DTC	P0A1D-165	Hybrid Powertrain Control Module
DTC	P0A1D-168	Hybrid Powertrain Control Module
DTC	P0A1D-198	Hybrid Powertrain Control Module
DTC	P0A1D-199	Hybrid Powertrain Control Module

DESCRIPTION

The HV control ECU performs self-checks to detect an internal operating malfunction in the ECU.

DTC No.	INF Code	DTC Detection Condition	Trouble Area
P0A1D	165 168 198 199	HV control ECU internal error	<ul style="list-style-type: none"> HV control ECU

MONITOR DESCRIPTION

The HV control ECU performs diagnostic monitoring to verify proper operation of internal and external ECU systems. In this diagnostic monitor, the HV control ECU checks for an R/D (Resolver / Digital Converter) malfunction involving the motor resolver.

If the HV control ECU detects an R/D error, it will conclude that there is an internal malfunction involving the motor resolver. The HV control ECU will illuminate the MIL and set a DTC.

HV

MONITOR STRATEGY

Related DTCs	P0A1D (INF 165 / 168 / 198 / 199): Motor R/D malfunction
Required sensor / components	Hybrid vehicle control ECU
Frequency of operation	Continuous
Duration	TOYOTA's intellectual property
MIL operation	1 driving cycle
Sequence of operation	None

TYPICAL ENABLING CONDITIONS

The monitor will run whenever the following DTCs are not present	TOYOTA's intellectual property
Other conditions belong to TOYOTA's intellectual property	-

TYPICAL MALFUNCTION THRESHOLDS

Hybrid vehicle control ECU	Internal error
----------------------------	----------------

COMPONENT OPERATING RANGE

Hybrid vehicle control ECU	DTC P0A1D (INF 165 / 168 / 198 / 199) is not detected
----------------------------	---

INSPECTION PROCEDURE

If any of the above information (INF) codes are present, replace the HV control ECU.

1**REPLACE HYBRID VEHICLE CONTROL ECU**

- (a) Replace the hybrid vehicle control ECU (see page [HV-543](#)).

NEXT**COMPLETED**

DTC	P0A1D-166	Hybrid Powertrain Control Module
DTC	P0A1D-167	Hybrid Powertrain Control Module
DTC	P0A1D-197	Hybrid Powertrain Control Module
DTC	P0A1D-200	Hybrid Powertrain Control Module

DESCRIPTION

The HV control ECU performs self-checks to detect an internal operating malfunction in the ECU.

DTC No.	INF Code	DTC Detection Condition	Trouble Area
P0A1D	166 167 197 200	HV control ECU internal error	<ul style="list-style-type: none"> HV control ECU

MONITOR DESCRIPTION

The HV control ECU performs diagnostic monitoring to verify proper operation of internal and external ECU systems. In this diagnostic monitor, the HV control ECU checks for an R/D (Resolver / Digital Converter) malfunction involving the generator resolver.

If the HV control ECU detects an R/D error, it will conclude that there is an internal malfunction involving the generator resolver. The HV control ECU will illuminate the MIL and set a DTC.

HV

MONITOR STRATEGY

Related DTCs	P0A1D (INF 166 / 167 / 197 / 200): Generator R/D malfunction
Required sensor / components	Hybrid vehicle control ECU
Frequency of operation	Continuous
Duration	TOYOTA's intellectual property
MIL operation	1 driving cycle
Sequence of operation	None

TYPICAL ENABLING CONDITIONS

The monitor will run whenever the following DTCs are not present	TOYOTA's intellectual property
Other conditions belong to TOYOTA's intellectual property	-

TYPICAL MALFUNCTION THRESHOLDS

Hybrid vehicle control ECU	Internal error
----------------------------	----------------

COMPONENT OPERATING RANGE

Hybrid vehicle control ECU	DTC P0A1D (INF 166 / 167 / 197 / 200) is not detected
----------------------------	---

INSPECTION PROCEDURE

If any of the above information (INF) codes are present, replace the HV control ECU.

1 REPLACE HYBRID VEHICLE CONTROL ECU

- (a) Replace the hybrid vehicle control ECU (see page [HV-543](#)).

NEXT**COMPLETED**

DTC	P0A1D-177	Hybrid Powertrain Control Module
DTC	P0A1D-178	Hybrid Powertrain Control Module
DTC	P0A1D-392	Hybrid Powertrain Control Module
DTC	P0A1D-567	Hybrid Powertrain Control Module

DESCRIPTION

The HV control ECU performs self-checks to detect an internal operating malfunction in the ECU.

DTC No.	INF Code	DTC Detection Condition	Trouble Area
P0A1D	177 178 392 567	HV control ECU internal error	<ul style="list-style-type: none"> HV control ECU

MONITOR DESCRIPTION

The HV control ECU performs many diagnostic tests to verify proper operation of internal and external ECU systems. In one of these diagnostics, the HV control ECU checks the result of the motor main CPU self-test.

If the HV control ECU detects a "Fail" from the motor main CPU self-test, it will conclude that there is an internal malfunction in the motor main CPU. The HV control ECU will illuminate the MIL and set a DTC.

HV

MONITOR STRATEGY

Related DTCs	P0A1D (INF 177 / 178 / 392 / 567): Motor main CPU malfunction
Required sensor / components	Hybrid vehicle control ECU
Frequency of operation	Continuous
Duration	TOYOTA's intellectual property
MIL operation	1 driving cycle
Sequence of operation	None

TYPICAL ENABLING CONDITIONS

The monitor will run whenever the following DTCs are not present	TOYOTA's intellectual property
Other conditions belong to TOYOTA's intellectual property	-

TYPICAL MALFUNCTION THRESHOLDS

Hybrid vehicle control ECU	Internal error
----------------------------	----------------

COMPONENT OPERATING RANGE

Hybrid vehicle control ECU	DTC P0A1D (INF 177 / 178 / 392 / 567) is not detected
----------------------------	---

INSPECTION PROCEDURE

If any of the above information (INF) codes are present, replace the HV control ECU.

1**REPLACE HYBRID VEHICLE CONTROL ECU**

- (a) Replace the hybrid vehicle control ECU (see page [HV-543](#)).

NEXT**COMPLETED**

DTC	P0A1D-180	Hybrid Powertrain Control Module
DTC	P0A1D-181	Hybrid Powertrain Control Module
DTC	P0A1D-182	Hybrid Powertrain Control Module
DTC	P0A1D-183	Hybrid Powertrain Control Module
DTC	P0A1D-184	Hybrid Powertrain Control Module
DTC	P0A1D-185	Hybrid Powertrain Control Module
DTC	P0A1D-186	Hybrid Powertrain Control Module

DESCRIPTION

The HV control ECU performs self-checks to detect an internal operating malfunction in the ECU.

HV

DTC No.	INF Code	DTC Detection Condition	Trouble Area
P0A1D	180 181 182 183 184 185 186	HV control ECU internal error	<ul style="list-style-type: none"> HV control ECU

MONITOR DESCRIPTION

The HV control ECU performs diagnostic monitoring to verify proper operation of internal and external ECU systems. In this diagnostics monitor, the HV control ECU monitors the output of the rotation angle CPU.

If the HV control ECU detects an error in the rotation angle CPU, it will conclude that there is an internal malfunction in the HV control ECU. The HV control ECU will illuminate the MIL and set a DTC.

MONITOR STRATEGY

Related DTCs	P0A1D (INF 180 / 181 / 182 / 183 / 184 / 185 / 186): Rotation angle monitor CPU malfunction
Required sensor / components	Hybrid vehicle control ECU
Frequency of operation	Continuous
Duration	TOYOTA's intellectual property
MIL operation	1 driving cycle
Sequence of operation	None

TYPICAL ENABLING CONDITIONS

The monitor will run whenever the following DTCs are not present	TOYOTA's intellectual property
Other conditions belong to TOYOTA's intellectual property	-

TYPICAL MALFUNCTION THRESHOLDS

Hybrid vehicle control ECU	Internal error
----------------------------	----------------

COMPONENT OPERATING RANGE

Hybrid vehicle control ECU	DTC P0A1D (INF 180 / 181 / 182 / 183 / 184 / 185 / 186) is not detected
----------------------------	---

INSPECTION PROCEDURE

If any of the above information (INF) codes are present, replace the HV control ECU.

1	REPLACE HYBRID VEHICLE CONTROL ECU
----------	---

- (a) Replace the hybrid vehicle control ECU (see page [HV-543](#)).

NEXT

COMPLETED

DTC	P0A1D- 187	Hybrid Powertrain Control Module
------------	-----------------------	---

DESCRIPTION

The HV control ECU performs self-checks to detect an internal operating malfunction in the ECU.

DTC No.	INF Code	DTC Detection Condition	Trouble Area
P0A1D	187	HV control ECU internal error	• HV control ECU

MONITOR DESCRIPTION

The HV control ECU performs diagnostic monitoring to verify proper operation of internal and external ECU systems. In one of these diagnostics, the HV control ECU monitors the important RAM circuits of the HV control ECU.

If the HV control ECU detects an error in the important RAM circuits, it will conclude that there is an internal malfunction in the HV control ECU. The HV control ECU will illuminate the MIL and set a DTC.

MONITOR STRATEGY

Related DTCs	P0A1D (INF 187): Important RAM error
Required sensor / components	Hybrid vehicle control ECU
Frequency of operation	Continuous
Duration	TOYOTA's intellectual property
MIL operation	1 driving cycle
Sequence of operation	None

TYPICAL ENABLING CONDITIONS

The monitor will run whenever the following DTCs are not present	TOYOTA's intellectual property
Other conditions belong to TOYOTA's intellectual property	-

TYPICAL MALFUNCTION THRESHOLDS

Important RAM address	Read / write check error
-----------------------	--------------------------

COMPONENT OPERATING RANGE

Hybrid vehicle control ECU	DTC P0A1D (INF 187) is not detected
----------------------------	-------------------------------------

INSPECTION PROCEDURE

If the above information (INF) code is present, replace the HV control ECU.

1	REPLACE HYBRID VEHICLE CONTROL ECU
----------	---

- (a) Replace the hybrid vehicle control ECU (see page [HV-543](#)).



COMPLETED

DTC	P0A1D-188	Hybrid Powertrain Control Module
DTC	P0A1D-189	Hybrid Powertrain Control Module
DTC	P0A1D-192	Hybrid Powertrain Control Module
DTC	P0A1D-193	Hybrid Powertrain Control Module
DTC	P0A1D-195	Hybrid Powertrain Control Module
DTC	P0A1D-196	Hybrid Powertrain Control Module
DTC	P0A1D-565	Hybrid Powertrain Control Module

DESCRIPTION

The HV control ECU performs self-checks to detect an internal operating malfunction in the ECU.

DTC No.	INF Code	DTC Detection Condition	Trouble Area
P0A1D	188 189 192 193 195 196 565	HV control ECU internal error	<ul style="list-style-type: none"> HV control ECU

HV

MONITOR DESCRIPTION

The HV control ECU performs many diagnostic tests to verify proper operation of internal and external ECU systems. In one of these diagnostics, the HV control ECU checks the result of the motor CPU self-test.

If the HV control ECU detects a "Fail" from the motor CPU self-test, it will conclude that there is an internal malfunction in the motor CPU. The HV control ECU will illuminate the MIL and set a DTC.

MONITOR STRATEGY

Related DTCs	P0A1D (INF 188 / 189 / 192 / 193 / 195 / 196 / 565): Motor CPU malfunction
Required sensor / components	Hybrid vehicle control ECU
Frequency of operation	Continuous
Duration	TOYOTA's intellectual property
MIL operation	1 driving cycle
Sequence of operation	None

TYPICAL ENABLING CONDITIONS

The monitor will run whenever the following DTCs are not present	TOYOTA's intellectual property
Other conditions belong to TOYOTA's intellectual property	-

TYPICAL MALFUNCTION THRESHOLDS

Hybrid vehicle control ECU	Internal error
----------------------------	----------------

COMPONENT OPERATING RANGE

Hybrid vehicle control ECU	DTC P0A1D (INF 188 / 189 / 192 / 193 / 195 / 196 / 565) is not detected
----------------------------	---

INSPECTION PROCEDURE

If any of the above information (INF) codes are present, replace the HV control ECU.

1	REPLACE HYBRID VEHICLE CONTROL ECU
----------	---

- (a) Replace the hybrid vehicle control ECU (see page [HV-543](#)).



COMPLETED

DTC	P0A1D-390	Hybrid Powertrain Control Module
------------	------------------	---

DESCRIPTION

The HV control ECU performs self-checks to detect an internal operating malfunction in the ECU.

DTC No.	INF Code	DTC Detection Condition	Trouble Area
P0A1D	390	Charge control malfunction	• HV control ECU

INSPECTION PROCEDURE

1	READ OUTPUT DTC (HV ECU)
----------	---------------------------------

- (a) Connect the intelligent tester to the DLC3.
- (b) Turn the power switch ON (IG).
- (c) Turn the intelligent tester ON.
- (d) Enter the following menus: DIAGNOSIS / OBD/MOBD / HV ECU / DTC INFO / CURRENT CODES.
- (e) Read DTCs.

Result:

DTC P0A1D (INF 390) and other DTCs are output

HINT:

If any other codes besides P0A1D (INF 390) are output, perform troubleshooting for those DTCs first.

YES
GO TO RELEVANT DTC CHART

NO

REPLACE HYBRID VEHICLE CONTROL ECU

DTC	P0A1D-393	Hybrid Powertrain Control Module
------------	------------------	---

DESCRIPTION

The HV control ECU performs self-checks to detect an internal operating malfunction in the ECU.

DTC No.	INF Code	DTC Detection Condition	Trouble Area
P0A1D	393	HV control ECU internal error	• HV control ECU

MONITOR DESCRIPTION

The HV control ECU performs many diagnostic tests to verify proper operation of internal ECU systems. In one of these diagnostics, the HV control ECU performs a self-test.

If the HV control ECU detects an internal problem during this self-test, it will conclude that there is an internal malfunction. The HV control ECU will illuminate the MIL and set a DTC.

MONITOR STRATEGY

Related DTCs	P0A1D (INF 393): HV CPU operation malfunction (routine check)
Required sensor / components	Hybrid vehicle control ECU
Frequency of operation	Continuous
Duration	TOYOTA's intellectual property
MIL operation	1 driving cycle
Sequence of operation	None

TYPICAL ENABLING CONDITIONS

The monitor will run whenever the following DTCs are not present	TOYOTA's intellectual property
Other conditions belong to TOYOTA's intellectual property	-

TYPICAL MALFUNCTION THRESHOLDS

Hybrid vehicle control ECU	Internal error
----------------------------	----------------

COMPONENT OPERATING RANGE

Hybrid vehicle control ECU	DTC P0A1D (INF 393) is not detected
----------------------------	-------------------------------------

INSPECTION PROCEDURE

If the above information (INF) code is present, replace the HV control ECU.

1	REPLACE HYBRID VEHICLE CONTROL ECU
----------	---

- (a) Replace the hybrid vehicle control ECU (see page [HV-543](#)).



COMPLETED

DTC	P0A1D-568	Hybrid Powertrain Control Module
------------	------------------	---

DTC	P0A1D-569	Hybrid Powertrain Control Module
------------	------------------	---

DESCRIPTION

The HV control ECU performs self-checks to detect an internal operating malfunction in the ECU.

DTC No.	INF Code	DTC Detection Condition	Trouble Area
P0A1D	568 569	HV control ECU internal error	<ul style="list-style-type: none"> HV control ECU

MONITOR DESCRIPTION

The HV control ECU performs diagnostic monitoring to verify proper operation of internal and external ECU systems. In this diagnostics monitor, the HV control ECU checks the REF signal from the motor main ECU for errors.

If the HV control ECU detects an error in the REF signal, it will conclude that there is a malfunction in the motor main CPU, the REF signal or the HV control ECU. The HV control ECU illuminates the MIL and sets a DTC.

MONITOR STRATEGY

Related DTCs	P0A1D (INF 568 / 569): Motor REF signal malfunction
Required sensor / components	Hybrid vehicle control ECU
Frequency of operation	Continuous
Duration	TOYOTA's intellectual property
MIL operation	1 driving cycle
Sequence of operation	None

HV

TYPICAL ENABLING CONDITIONS

The monitor will run whenever the following DTCs are not present	TOYOTA's intellectual property
Other conditions belong to TOYOTA's intellectual property	-

TYPICAL MALFUNCTION THRESHOLDS

REF signal	Abnormal
------------	----------

COMPONENT OPERATING RANGE

Hybrid vehicle control ECU	DTC P0A1D (INF 568 / 569) is not detected
----------------------------	---

INSPECTION PROCEDURE

1	READ OUTPUT DTC (HV ECU)
----------	---------------------------------

- (a) Connect the intelligent tester to the DLC3.
- (b) Turn the power switch ON (IG).

- (c) Turn the intelligent tester ON.
- (d) Enter the following menus: DIAGNOSIS / OBD/MOBD / HV ECU / DTC INFO / CURRENT CODES.
- (e) Read DTCs.

Result:

DTC P0A0F (INF 243), P0A40 (INF 500) or P0A41 (INF 245) for the motor resolver is output

YES 

GO TO RELEVANT DTC CHART

NO

REPLACE HYBRID VEHICLE CONTROL ECU

DTC	P0A1D-615	Hybrid Powertrain Control Module
------------	------------------	---

DESCRIPTION

The HV control ECU performs self-checks to detect an internal operating malfunction in the ECU.

DTC No.	INF Code	DTC Detection Condition	Trouble Area
P0A1D	615	HV control ECU internal error	• HV control ECU

MONITOR DESCRIPTION

The HV control ECU performs diagnostic monitoring to verify proper operation of internal and external ECU systems. In this diagnostics monitor, the HV control ECU checks the communication bus off count and the message register of the CAN (Controller Area Network) controller.

If the HV control ECU detects an error in the communication bus off count or message register, it will conclude that there is a malfunction in the HV control ECU. The HV control ECU illuminates the MIL and sets a DTC.

MONITOR STRATEGY

Related DTCs	P0A1D (INF 615): CAN communication malfunction
Required sensor / components	Hybrid vehicle control ECU
Frequency of operation	Continuous
Duration	TOYOTA's intellectual property
MIL operation	1 driving cycle
Sequence of operation	None

TYPICAL ENABLING CONDITIONS

The monitor will run whenever the following DTCs are not present	TOYOTA's intellectual property
Other conditions belong to TOYOTA's intellectual property	-

HV

TYPICAL MALFUNCTION THRESHOLDS

Case 1:

Message register of the CAN controller	Read / write check error
--	--------------------------

Case 2:

Communication bus off count	Designed number or more
-----------------------------	-------------------------

COMPONENT OPERATING RANGE

Hybrid vehicle control ECU	DTC P0A1D (INF 615) is not detected
----------------------------	-------------------------------------

INSPECTION PROCEDURE

If the above information (INF) code is present, replace the HV control ECU.

1	REPLACE HYBRID VEHICLE CONTROL ECU
----------	---

- (a) Replace the hybrid vehicle control ECU (see page [HV-543](#)).

NEXT

COMPLETED

DTC	P0A1F- 123	Battery Energy Control Module
------------	-----------------------	--------------------------------------

DESCRIPTION

Based on a malfunction signal received from the battery ECU, the HV control ECU alerts the driver and effects fail-safe control.

DTC No.	INF Code	DTC Detection Condition	Trouble Area
P0A1F	123	Abnormal signal input from battery ECU (ROM/RAM malfunction)	<ul style="list-style-type: none"> • HV battery system • Battery ECU

MONITOR DESCRIPTION

Upon receiving an abnormal signal input from the battery ECU, the HV control ECU illuminates the MIL and sets a DTC.

MONITOR STRATEGY

Related DTCs	P0A1F (INF 123): Battery ECU / Rationality
Required sensor / components	Battery ECU, battery current sensor
Frequency of operation	Continuous
Duration	TOYOTA's intellectual property
MIL operation	Immediately
Sequence of operation	None

TYPICAL ENABLING CONDITIONS

The monitor will run whenever the following DTCs are not present	TOYOTA's intellectual property
Other conditions belong to TOYOTA's intellectual property	-

TYPICAL MALFUNCTION THRESHOLDS

TOYOTA's intellectual property	-
--------------------------------	---

COMPONENT OPERATING RANGE

Battery ECU	Normal
-------------	--------

INSPECTION PROCEDURE

HINT:

After repairing the malfunction, restart the system (to turn the READY light ON) and recheck the DTC.

1	READ OUTPUT DTC (HV BATTERY)
----------	-------------------------------------

- (a) Connect the intelligent tester to the DLC3.
- (b) Turn the power switch ON (IG).
- (c) Turn the intelligent tester ON.
- (d) Enter the following menus: DIAGNOSIS / OBD/MOBD / HV BATTERY / DTC INFO / TROUBLE CODES.
- (e) Read DTCs.

Result:
DTCs are output

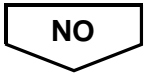

DTC	P0A1F- 129	Battery Energy Control Module
------------	-----------------------	--------------------------------------

DESCRIPTION

The battery ECU transmits information on the HV battery voltage to the HV control ECU via CAN communication.

DTC No.	INF Code	DTC Detection Condition	Trouble Area
P0A1F	129	HV battery voltage circuit malfunction	<ul style="list-style-type: none"> • HV battery voltage circuit • Service plug grip • High voltage fuse • Battery plug • Battery ECU

MONITOR DESCRIPTION

The HV control ECU calculates the differences between the received HV battery voltage, boost converter voltage, and inverter voltage. If any of the differences exceed prescribed values, the HV control ECU determines that there is a malfunction in the battery voltage circuit. When the HV control ECU detects a malfunction, it illuminates the MIL and sets a DTC.

MONITOR STRATEGY

Related DTCs	P0A1F (INF 129): Battery ECU / Voltage (VB) sensor deviation
Required sensor / components	Battery ECU, boost converter, inverter
Frequency of operation	Continuous
Duration	TOYOTA's intellectual property
MIL operation	Immediately
Sequence of operation	None

TYPICAL ENABLING CONDITIONS

The monitor will run whenever the following DTCs are not present	TOYOTA's intellectual property
Other conditions belong to TOYOTA's intellectual property	-

TYPICAL MALFUNCTION THRESHOLDS

TOYOTA's intellectual property	-
--------------------------------	---

COMPONENT OPERATING RANGE

Battery ECU	Normal
-------------	--------

WIRING DIAGRAM

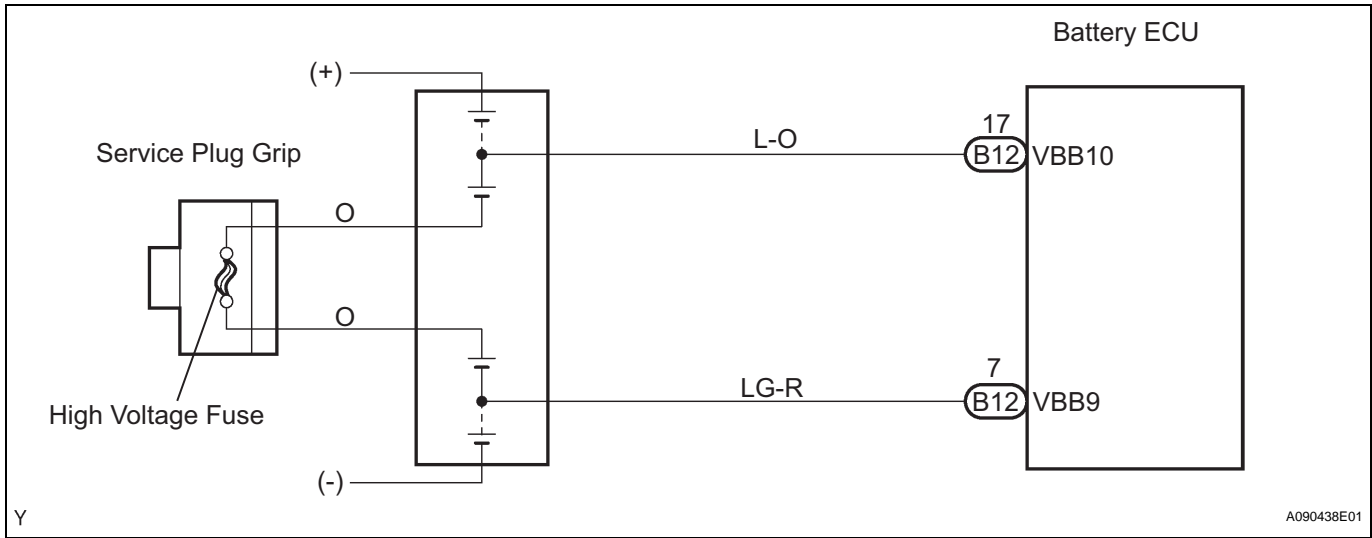

INSPECTION PROCEDURE

CAUTION:

- Before inspecting the high-voltage system, take safety precautions to prevent electrical shocks, such as wearing insulated gloves and removing the service plug grip. After removing the service plug grip, put it in your pocket to prevent other technicians from reconnecting it while you are servicing the high-voltage system.
- After disconnecting the service plug grip, wait for at least 5 minutes before touching any of the high-voltage connectors or terminals.

HINT:

At least 5 minutes are required to discharge the high-voltage condenser inside the inverter.

HV

1 READ OUTPUT DTC (HV BATTERY)

- Connect the intelligent tester to the DLC3.
- Turn the power switch ON (IG).
- Turn the intelligent tester ON.
- Enter the following menus: DIAGNOSIS / OBD/MOBD / HV BATTERY / DTC INFO / TROUBLE CODES.
- Read DTCs.

Result:

DTCs are output

YES → **GO TO RELEVANT DTC CHART**

NO

2 READ OUTPUT DTC (HV ECU)

- Connect the intelligent tester to the DLC3.
- Turn the power switch ON (IG).
- Turn the intelligent tester ON.
- Enter the following menus: DIAGNOSIS / OBD/MOBD / HV ECU / DTC INFO / CURRENT CODES.
- Read DTCs.

Result:
DTCs listed in the table below are output

DTC No.	INF Code	Detection Item	See Page
P0ADC	226	Hybrid Battery Positive Contactor Control Circuit High	HV-439
P0ADB	227	Hybrid Battery Positive Contactor Control Circuit Low	HV-439
P0AE0	228	Hybrid Battery Negative Contactor Control Circuit High	HV-441
P0ADF	229	Hybrid Battery Negative Contactor Control Circuit Low	HV-441

YES → **GO TO THE PAGE NUMBER SHOWN IN THE TABLE ABOVE**

NO

3 INSPECT SERVICE PLUG GRIP

CAUTION:

Wear insulated gloves before performing the following operation.

- (a) Turn the power switch OFF.
- (b) Remove the service plug grip (see page [HB-154](#)).

NOTICE:

Turning the power switch ON (READY) with the service plug grip removed could cause malfunction. Therefore, never turn the power switch ON (READY) in this state.

- (c) Measure the resistance between the terminals of the service plug grip.

Standard resistance:

Below 1 Ω

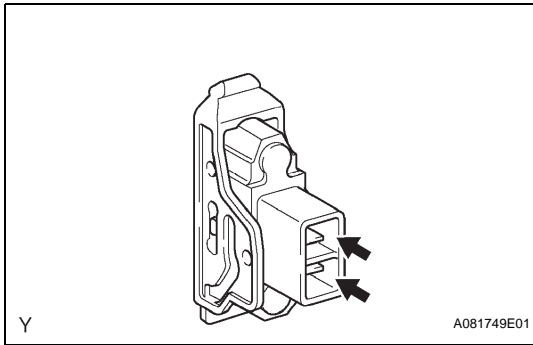

NG → **Go to step 5**

OK

4 INSPECT BATTERY PLUG

CAUTION:

Wear insulated gloves and goggles before performing the following operation.

- (a) Remove the HV battery assembly (see page [HB-92](#)).
- (b) Remove the battery plug (see page [HB-113](#)).
- (c) Measure the resistance between the terminals of the battery plug.

Standard resistance

Tester Connection	Specified Condition
A - C	Below 1 Ω
B - D	Below 1 Ω

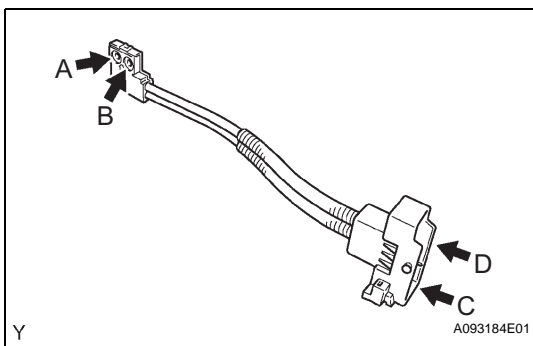

- (d) Reinstall the battery plug (see page [HB-114](#)).
- (e) Reinstall the HV battery assembly (see page [HB-96](#)).

NG

REPLACE BATTERY PLUG

OK

REPLACE BATTERY ECU ASSEMBLY

5

INSPECT HIGH VOLTAGE FUSE

CAUTION:**Wear insulated gloves before performing the following operation.**

- (a) Remove the high voltage fuse (see page
- [HB-154](#)
-).

HINT:

The high voltage fuse is enclosed in the service plug grip.

- (b) Measure the resistance between the terminals of the high voltage fuse.

Standard resistance:**Below 1 Ω**

- (c) Reinstall the high voltage fuse (see page
- [HB-154](#)
-).

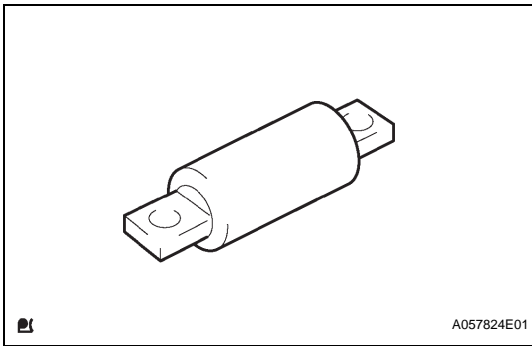

NG

REPLACE HIGH VOLTAGE FUSE

OK

REPLACE SERVICE PLUG GRIP

DTC	P0A1F- 593	Battery Energy Control Module
------------	-----------------------	--------------------------------------

DESCRIPTION

The battery ECU transmits information on the IG2 voltage of the battery ECU to the HV control ECU via CAN communication.

DTC No.	INF Code	DTC Detection Condition	Trouble Area
P0A1F	593	IG2 signal circuit of battery ECU malfunction	<ul style="list-style-type: none"> • Wire harness or connector • Battery ECU

MONITOR DESCRIPTION

When the IG2 voltage of the battery ECU, which is transmitted while the power switch is ON (IG), is low, the HV control ECU determines that a wiring malfunction has occurred at the IG2 terminal of the battery ECU. When the HV control ECU detects the malfunction, it illuminates the MIL and sets a DTC.

MONITOR STRATEGY

Related DTCs	P0A1F (INF 593): IG2 signal malfunction
Required sensor / components	Battery ECU
Frequency of operation	Continuous
Duration	TOYOTA's intellectual property
MIL operation	1 driving cycle
Sequence of operation	None

TYPICAL ENABLING CONDITIONS

The monitor will run whenever the following DTCs are not present	TOYOTA's intellectual property
Other conditions belong to TOYOTA's intellectual property	-

TYPICAL MALFUNCTION THRESHOLDS

Following conditions are met:	(a) and (b)
(a) IG2 signal status at HV control ECU	ON
(b) IG2 signal status from battery ECU	OFF

COMPONENT OPERATING RANGE

Battery ECU	DTC P0A1F (INF 593) is not detected
-------------	-------------------------------------

WIRING DIAGRAM

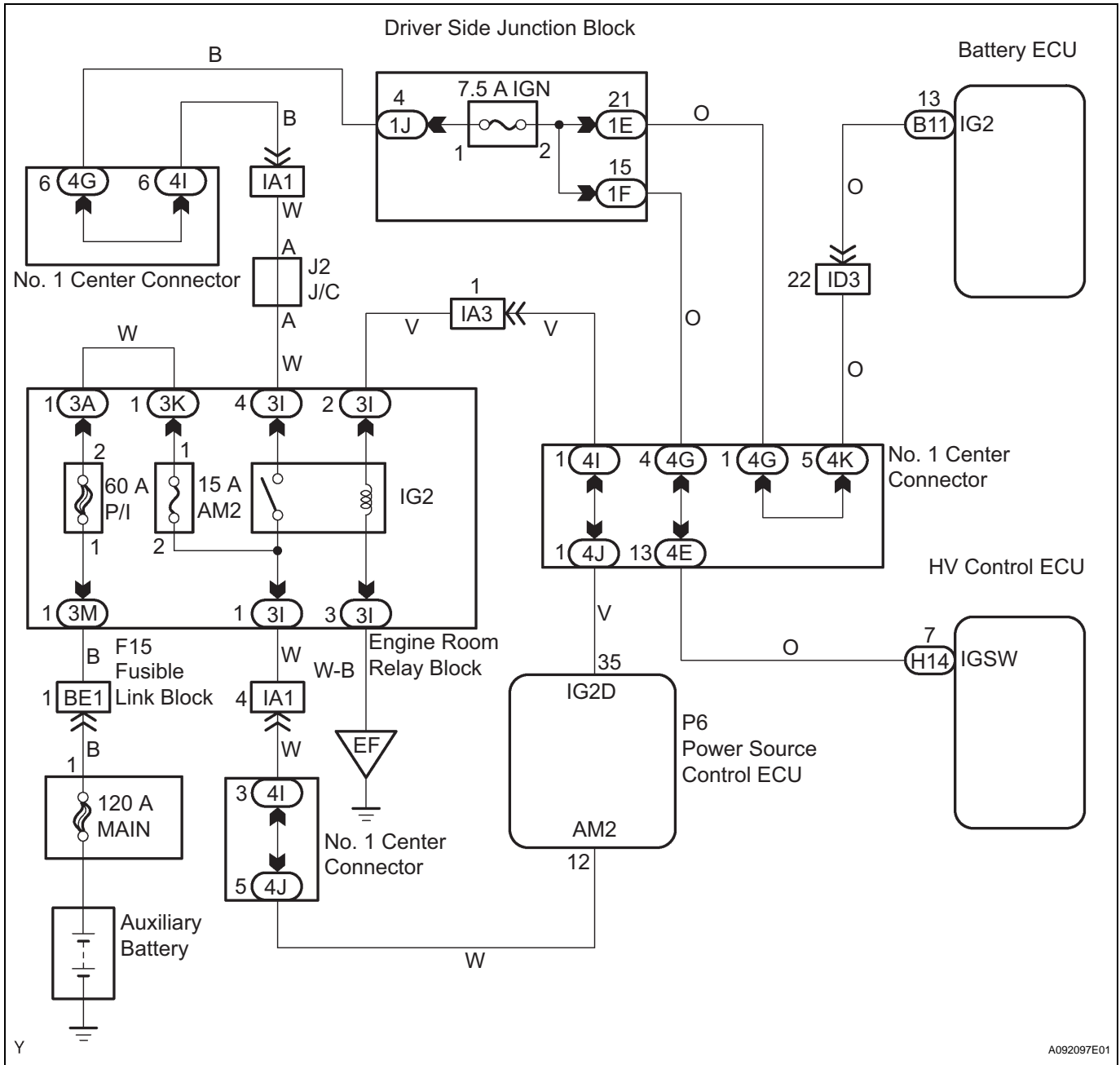

INSPECTION PROCEDURE

1 CHECK HARNESS AND CONNECTOR (BATTERY ECU - IGN FUSE)

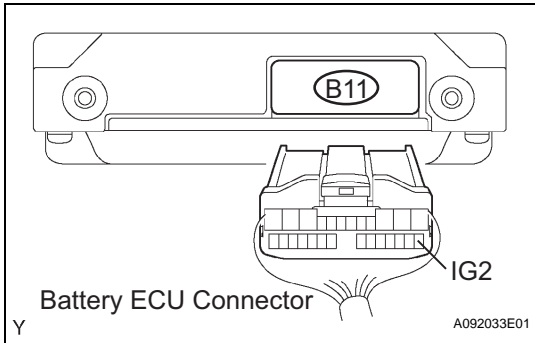

(a) Disconnect the B11 battery ECU connector.

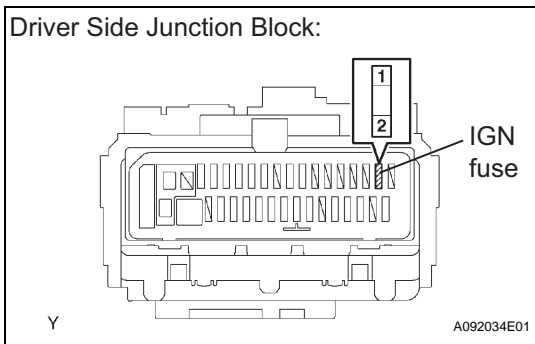

(b) Remove the IGN fuse from the driver side junction block.
 (c) Measure the resistance between the wire harness side connectors.

Standard resistance (Check for open)

Tester Connection	Specified Condition
IG2 (B11-13) - IGN fuse (2)	Below 1 Ω

Standard resistance (Check for short)

Tester Connection	Specified Condition
IG2 (B11-13) or IGN fuse (2) - Body ground	10 kΩ or higher

NOTICE:

When taking a measurement with a tester, do not apply excessive force to the tester probe to avoid damaging the holder.

(d) Reinstall the IGN fuse.
 (e) Reconnect the battery ECU connector.

NG **REPAIR OR REPLACE HARNESS OR CONNECTOR**

OK

REPLACE BATTERY ECU ASSEMBLY

DTC	P0A2B-248	Drive Motor "A" Temperature Sensor Circuit Range / Performance
------------	------------------	---

DTC	P0A2B-250	Drive Motor "A" Temperature Sensor Circuit Range / Performance
------------	------------------	---

DESCRIPTION

Refer to DTC P0A2C (INF 247) (see page [HV-187](#)).

DTC No.	INF Code	DTC Detection Condition	Trouble Area
P0A2B	248	No. 1 motor temperature sensor malfunction	<ul style="list-style-type: none"> Hybrid vehicle motor
P0A2B	250	No. 1 motor temperature sensor performance problem	<ul style="list-style-type: none"> Hybrid vehicle motor

INSPECTION PROCEDURE

If the information (INF) code 248 or 250 is present, replace the hybrid vehicle motor.

HINT:

The No. 1 motor temperature sensor is unavailable as an individual service part. Therefore, when replacing it, the hybrid vehicle motor must be replaced.

1	REPLACE HYBRID VEHICLE MOTOR ASSEMBLY
----------	--

NEXT

COMPLETED

DTC	P0A2C-247	Drive Motor "A" Temperature Sensor Circuit Low
DTC	P0A2D-249	Drive Motor "A" Temperature Sensor Circuit High

DESCRIPTION

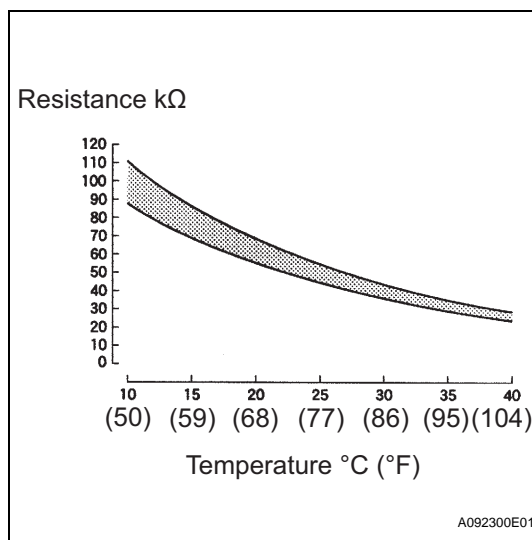

The resistance of the thermistor, which is enclosed in the No. 1 motor temperature sensor, changes in accordance with the changes in the temperature of the motor. The lower the motor temperature, the higher the resistance of the thermistor. Conversely, the higher the temperature, the lower the resistance. The No. 1 motor temperature sensor is connected to the HV control ECU. The power voltage of 5 V is supplied from the MMT terminal of the HV control ECU to the No. 1 motor temperature sensor via resistor R. Because resistor R and the No. 1 motor temperature sensor are connected in series, the resistance changes with the changes in temperature of the motor, which causes the MMT terminal voltage to also change.

Based on this signal, the HV control ECU limits the load in order to prevent the motor from overheating. Furthermore, the HV control ECU checks the No. 1 motor temperature sensor for a wiring malfunction and the sensor for a malfunction.

HV

DTC No.	INF Code	DTC Detection Condition	Trouble Area
P0A2C	247	GND short in No. 1 motor temperature sensor circuit	<ul style="list-style-type: none"> Wire harness or connector Hybrid vehicle motor HV control ECU
P0A2D	249	Open or +B short in No. 1 motor temperature sensor circuit	<ul style="list-style-type: none"> Wire harness or connector Hybrid vehicle motor HV control ECU

HINT:

After confirming DTC P0A2C (INF 247) or P0A2D (INF 249), confirm MOTOR 1 TEMP in DIAGNOSIS / OBD/MOBD / HV ECU / DATA LIST using the intelligent tester.

Temperature Displayed	Malfunction
50°C (-58°F)	Open or +B short circuit
205°C (401°F)	GND short circuit

WIRING DIAGRAM

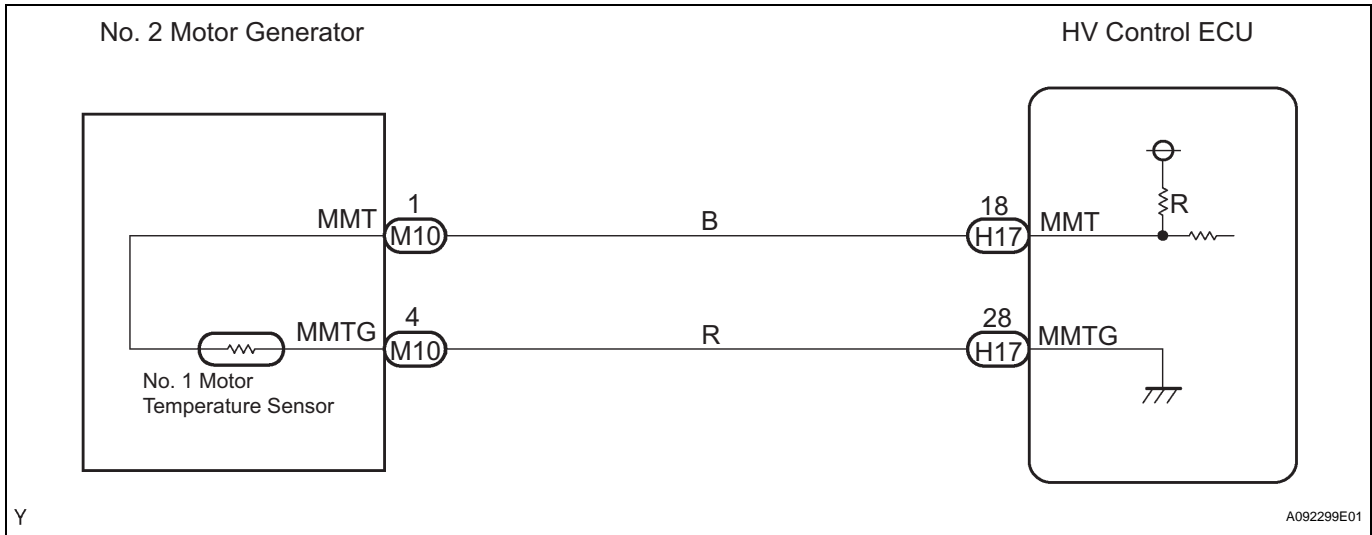

INSPECTION PROCEDURE

1 READ VALUE OF INTELLIGENT TESTER (MOTOR 1 TEMP)

- (a) Connect the intelligent tester to the DLC3.
- (b) Turn the power switch ON (IG).
- (c) Turn the intelligent tester ON.
- (d) Enter the following menus: DIAGNOSIS / OBD/MOBD / HV ECU / DATA LIST.
- (e) Read the MOTOR 1 TEMP value.

Result:

Temperature Displayed	Proceed to
-50°C (-58°F)	A
205°C (401°F)	B
-49°C to 204°C (-57°F to 400°F)	C

HINT:

- If there is an open or +B short circuit, the intelligent tester indicates -50°C (-58°F).
- If there is a GND short circuit, the intelligent tester indicates 205°C (401°F).

B → **Go to step 5**

C → **CHECK FOR INTERMITTENT PROBLEMS**

A

2 INSPECT HYBRID VEHICLE MOTOR ASSEMBLY (CHECK FOR OPEN OR +B SHORT)

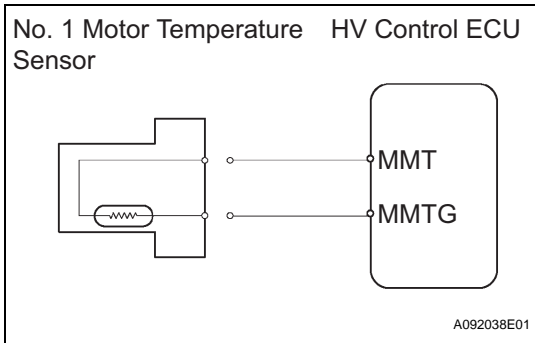

- (a) Disconnect the M10 No. 1 motor temperature sensor connector.
- (b) Turn the power switch ON (IG).

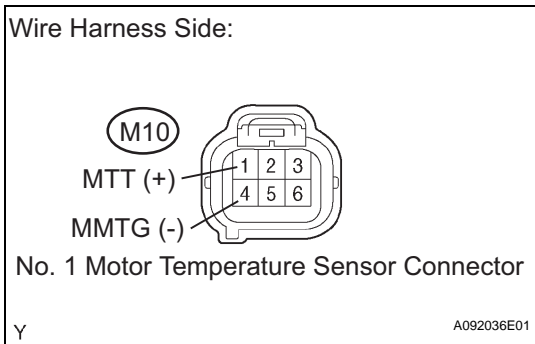

- (c) Measure the voltage between the terminals of the No. 1 motor temperature sensor connector.

Result:

Tester Connection	Voltage	Proceed to
MMT (M10-1) - MMTG (M10-4)	Approximately 5 V	A
MMT (M10-1) - MMTG (M10-4)	9 to 14 V	B
MMT (M10-1) - MMTG (M10-4)	Approximately 0 V	C

HINT:

The No. 1 motor temperature sensor is unavailable as an individual service part. Therefore, when replacing it, the hybrid vehicle motor must be replaced.

- (d) Reconnect the No. 1 motor temperature sensor connector.

A	REPLACE HYBRID VEHICLE MOTOR ASSEMBLY
C	Go to step 4

B

3 CHECK HARNESS AND CONNECTOR (CHECK FOR +B SHORT)

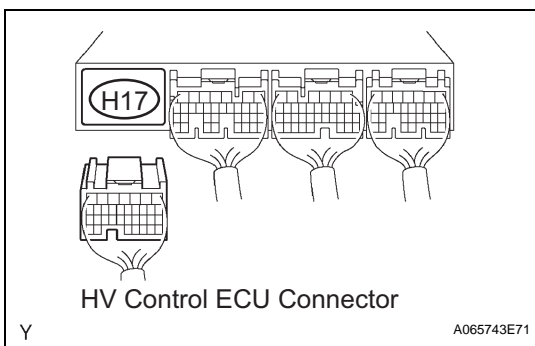

- (a) Disconnect the H17 HV control ECU connector.

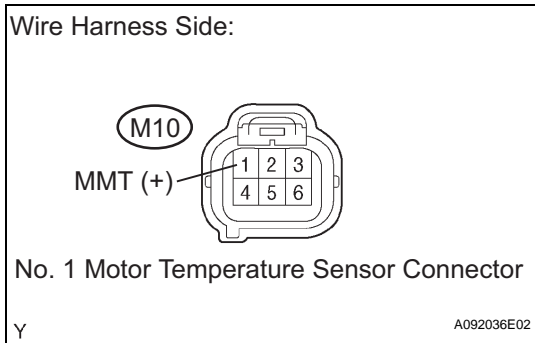

- (b) Disconnect the M10 No. 1 motor temperature sensor connector.
- (c) Turn the power switch ON (IG).
- (d) Measure the voltage between the terminal of the No. 1 motor temperature sensor connector and body ground.

Standard voltage

Tester Connection	Specified Condition
MMT (M10-1) - Body ground	Approximately 0 V

- (e) Reconnect the HV control ECU connector.
- (f) Reconnect the No. 1 motor temperature sensor connector.

NG REPAIR OR REPLACE HARNESS OR CONNECTOR

OK

REPLACE HYBRID VEHICLE CONTROL ECU

4 READ VALUE OF INTELLIGENT TESTER (CHECK FOR OPEN IN HYBRID VEHICLE CONTROL ECU)

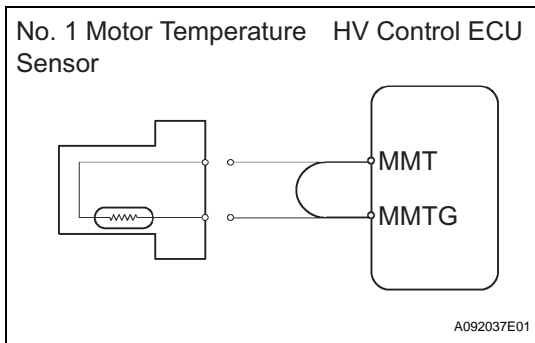

- (a) Disconnect the M10 No. 1 motor temperature sensor connector.

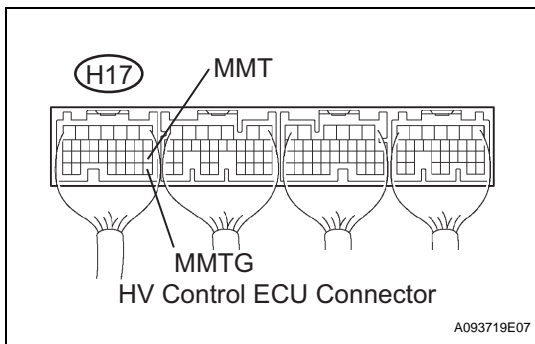

- (b) Connect terminals MMT and MMTG of the H17 HV control ECU connector.
- (c) Turn the power switch ON (IG).
- (d) Enter the following menus: DIAGNOSIS / OBD/MOBD / HV ECU / DATA LIST.
- (e) Read the MOTOR 1 TEMP value.

OK:
205°C (401°F)

HINT:
If the intelligent tester indicates a temperature of -50°C (-58°F), check the connection of the HV control ECU. If it is connected normally, replace the HV control ECU.

- (f) Reconnect the No. 1 motor temperature sensor connector.

NG REPLACE HYBRID VEHICLE CONTROL ECU

HV

OK

REPAIR OR REPLACE HARNESS OR CONNECTOR

5 READ VALUE OF INTELLIGENT TESTER (CHECK FOR GND SHORT IN WIRE HARNESS)

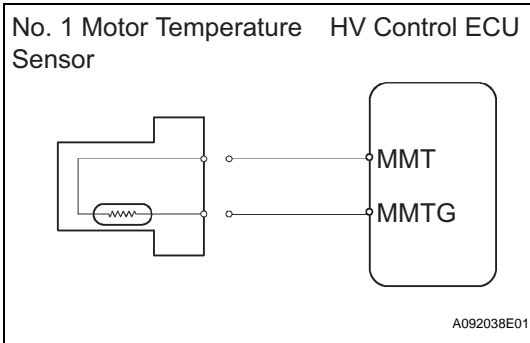

- (a) Disconnect the M10 No. 1 motor temperature sensor connector.
- (b) Turn the power switch ON (IG).
- (c) Enter the following menus: DIAGNOSIS / OBD/MOBD / HV ECU / DATA LIST.
- (d) Read the MOTOR 1 TEMP value.

OK:
-50°C (-58°F)

- (e) Reconnect the No. 1 motor temperature sensor connector.

HINT:

The No. 1 motor temperature sensor is unavailable as an individual service part. Therefore, when replacing it, the hybrid vehicle motor must be replaced.

OK

REPLACE HYBRID VEHICLE MOTOR ASSEMBLY

NG

6 READ VALUE OF INTELLIGENT TESTER (CHECK FOR GND SHORT IN HYBRID VEHICLE CONTROL ECU)

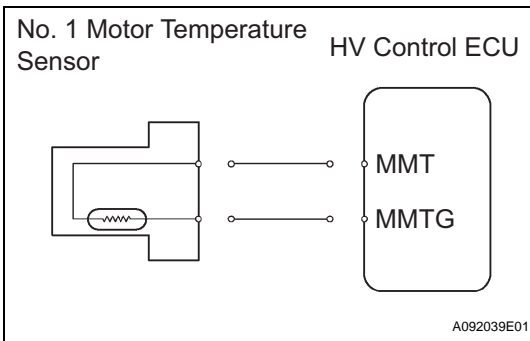
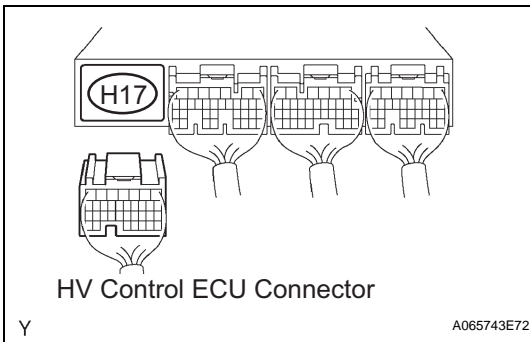

- (a) Disconnect the H17 HV control ECU connector.

- (b) Turn the power switch ON (IG).
- (c) Enter the following menus: DIAGNOSIS / OBD/MOBD / HV ECU / DATA LIST.
- (d) Read the MOTOR 1 TEMP value.

OK:
-50°C (-58°F)

- (e) Reconnect the HV control ECU connector.

NG

REPLACE HYBRID VEHICLE CONTROL ECU

HV

OK

REPAIR OR REPLACE HARNESS OR CONNECTOR

DTC	P0A37-258	Generator Temperature Sensor Circuit Range / Performance
------------	------------------	---

DESCRIPTION

Refer to DTC P0A38 (INF 257) (see page [HV-195](#)).

DTC No.	INF Code	DTC Detection Condition	Trouble Area
P0A37	258	No. 2 motor temperature sensor malfunction	<ul style="list-style-type: none"> Hybrid vehicle motor

INSPECTION PROCEDURE

If the information (INF) code 258 is present, replace the hybrid vehicle motor.

HINT:

The No. 2 motor temperature sensor is unavailable as an individual service part. Therefore, when replacing it, the hybrid vehicle motor must be replaced.

1	REPLACE HYBRID VEHICLE MOTOR ASSEMBLY
----------	--

NEXT

COMPLETED

DTC	P0A37-260	Generator Temperature Sensor Circuit Range / Performance
------------	------------------	---

DESCRIPTION

Refer to DTC P0A38 (INF 257) (see page [HV-195](#)).

DTC No.	INF Code	DTC Detection Condition	Trouble Area
P0A37	260	No. 2 motor temperature sensor performance problem	<ul style="list-style-type: none"> • Hybrid vehicle motor • Transaxle fluid leakage • HV transaxle assembly

INSPECTION PROCEDURE

1	CHECK TRANSAXLE FLUID LEVEL
----------	------------------------------------

- (a) Check if the transaxle is filled with fluid to the specified level.

OK:

The transaxle is filled with fluid to the specified level

HINT:

The No. 2 motor temperature sensor is unavailable as an individual service part. Therefore, when replacing it, the hybrid vehicle motor must be replaced.

NG	REPAIR OIL LEAKAGE, OR REPLACE HYBRID VEHICLE TRANSAXLE
-----------	--

OK

REPLACE HYBRID VEHICLE MOTOR ASSEMBLY
--

DTC	P0A38-257	Generator Temperature Sensor Circuit Low
------------	------------------	---

DTC	P0A39-259	Generator Temperature Sensor Circuit High
------------	------------------	--

DESCRIPTION

The No. 2 motor temperature sensor detects the temperature of the transaxle fluid. The resistance of the thermistor installed in the No. 2 motor temperature sensor varies with the changes in the transaxle fluid temperature. The construction in the No. 2 motor temperature sensor and how it is connected to the HV control ECU are the same as those of the No. 1 motor temperature sensor (see page HV-187).

Based on the signal provided by the No. 2 motor temperature sensor, the HV control ECU limits the load to prevent the motor from overheating. Furthermore, the HV control ECU checks the No. 2 motor temperature sensor for a wiring malfunction and the sensor for a malfunction.

DTC No.	INF Code	DTC Detection Condition	Trouble Area
P0A38	257	GND short in No. 2 motor temperature sensor circuit	<ul style="list-style-type: none"> Wire harness or connector Hybrid vehicle motor HV control ECU
P0A39	259	Open or +B short in No. 2 motor temperature sensor circuit	<ul style="list-style-type: none"> Wire harness or connector Hybrid vehicle motor HV control ECU

HINT:

After confirming DTC P0A38 (INF 257) or P0A39 (INF 259), confirm MOTOR 2 TEMP in DIAGNOSIS / OBD/MOBD / HV ECU / DATA LIST using the intelligent tester.

Temperature Displayed	Malfunction
-50°C (-58°F)	Open or +B short circuit
205°C (401°F)	GND short circuit

HV

WIRING DIAGRAM

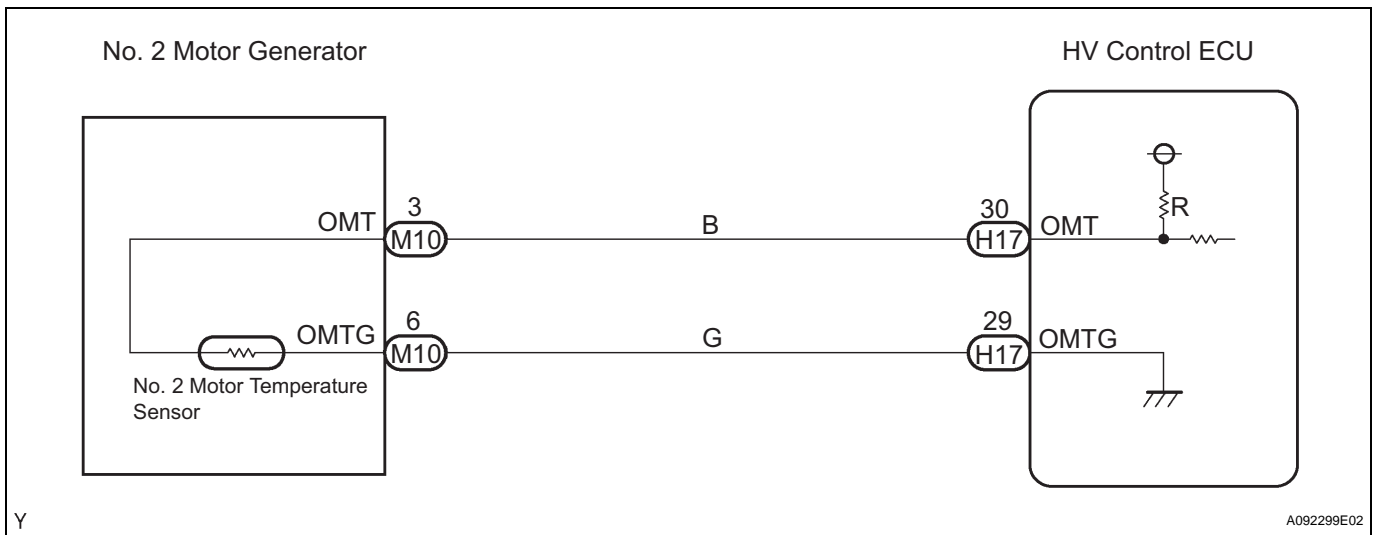

Y

A092299E02

INSPECTION PROCEDURE

1 READ VALUE OF INTELLIGENT TESTER (MOTOR 2 TEMP)

- (a) Connect the intelligent tester to the DLC3.
- (b) Turn the power switch ON (IG).
- (c) Turn the intelligent tester ON.
- (d) Enter the following menus: DIAGNOSIS / OBD/MOBD / HV ECU / DATA LIST.
- (e) Read the MOTOR 2 TEMP value.

Result:

Temperature Displayed	Proceed to
-50°C (-58°F)	A
205°C (401°F)	B
-49°C to 204°C (-57°F to 400°F)	C

HINT:

- If there is an open or +B short circuit, the intelligent tester indicates -50°C (-58°F).
- If there is a GND short circuit, the intelligent tester indicates 205°C (401°F).

B → **Go to step 5**

C → **CHECK FOR INTERMITTENT PROBLEMS**

A

2 INSPECT HYBRID VEHICLE MOTOR ASSEMBLY (CHECK FOR OPEN OR +B SHORT)

HV

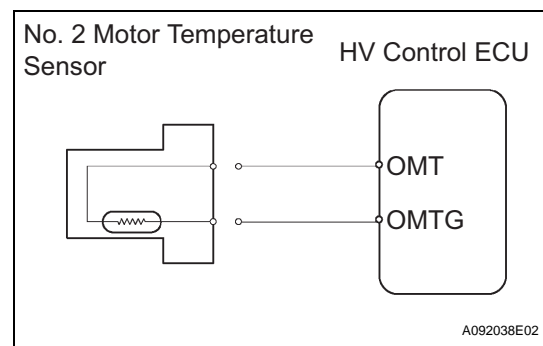

- (a) Disconnect the M10 No. 2 motor temperature sensor connector.
- (b) Turn the power switch ON (IG).

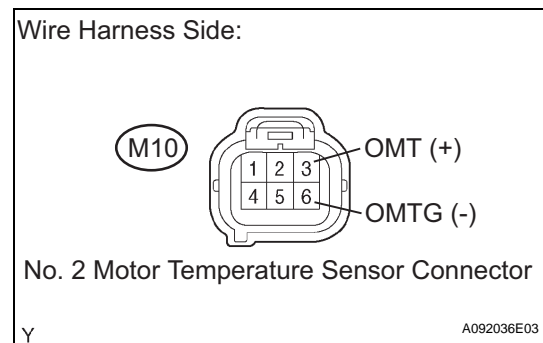

- (c) Measure the voltage between the terminals of the No. 2 motor temperature sensor connector.

Result:

Tester Connection	Voltage	Proceed to
OMT (M10-3) - OMTG (M10-6)	Approximately 5 V	A
OMT (M10-3) - OMTG (M10-6)	9 to 14 V	B
OMT (M10-3) - OMTG (M10-6)	Approximately 0 V	C

HINT:

The No. 2 motor temperature sensor is unavailable as an individual service part. Therefore, when replacing it, the hybrid vehicle motor must be replaced.

- (d) Reconnect the No. 2 motor temperature sensor connector.

A	REPLACE HYBRID VEHICLE MOTOR ASSEMBLY
C	Go to step 4

B

3 CHECK HARNESS AND CONNECTOR (CHECK FOR +B SHORT)

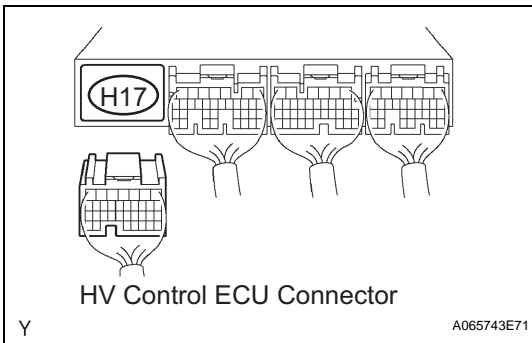

- (a) Disconnect the H17 HV control ECU connector.

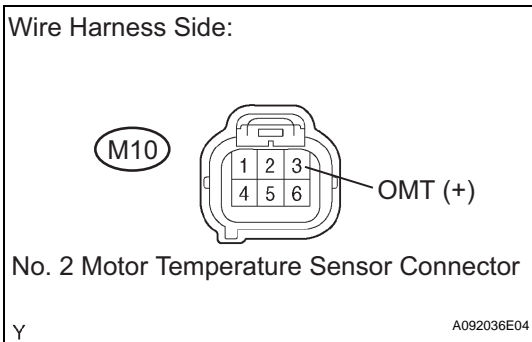

- (b) Disconnect the M10 No. 2 motor temperature sensor connector.
 - (c) Turn the power switch ON (IG).
 - (d) Measure the voltage between the terminal of the No. 2 motor temperature sensor connector and body ground.
- Standard voltage**

Tester Connection	Specified Condition
OMT (M10-3) - Body ground	Approximately 0 V

- (e) Reconnect the HV control ECU connector.
- (f) Reconnect the No. 2 motor temperature sensor connector.

NG	REPAIR OR REPLACE HARNESS OR CONNECTOR
-----------	---

OK

REPLACE HYBRID VEHICLE CONTROL ECU

HV

4 READ VALUE OF INTELLIGENT TESTER (CHECK FOR OPEN IN HYBRID VEHICLE CONTROL ECU)

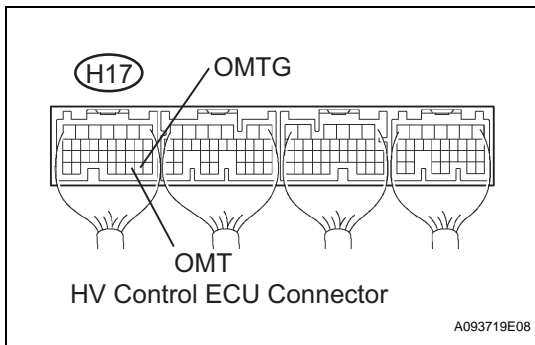
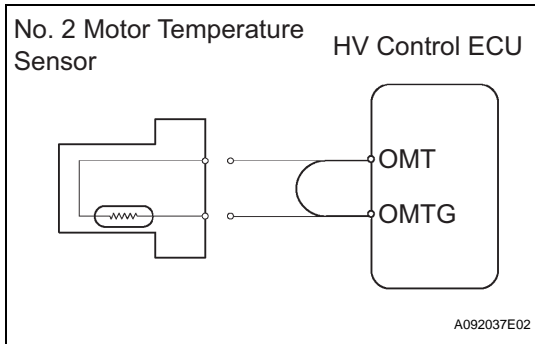

- (a) Disconnect the M10 No. 2 motor temperature sensor connector.
- (b) Connect terminals OMT and OMTG of the H17 HV control ECU connector.
- (c) Turn the power switch ON (IG).
- (d) Enter the following menus: DIAGNOSIS / OBD/MOBD / HV ECU / DATA LIST.
- (e) Read the MOTOR 2 TEMP value.
OK:
205°C (401°F)
HINT:
 If the intelligent tester indicates a temperature of -50°C (-58°F), check the connection of the HV control ECU. If it is connected normally, replace the HV control ECU.
- (f) Reconnect the No. 2 motor temperature sensor connector.

NG **REPLACE HYBRID VEHICLE CONTROL ECU**

OK

REPAIR OR REPLACE HARNESS OR CONNECTOR

5 READ VALUE OF INTELLIGENT TESTER (CHECK FOR GND SHORT IN WIRE HARNESS)

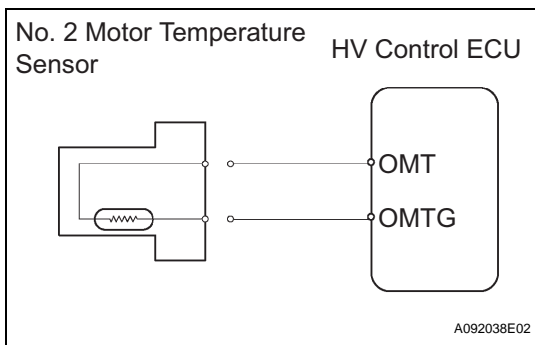

- (a) Disconnect the M10 No. 2 motor temperature sensor connector.
- (b) Turn the power switch ON (IG).
- (c) Enter the following menus: DIAGNOSIS / OBD/MOBD / HV ECU / DATA LIST.
- (d) Read the MOTOR 2 TEMP value.
OK:
-50°C (-58°F)
HINT:
 The No. 2 motor temperature sensor is unavailable as an individual service part. Therefore, when replacing it, the hybrid vehicle motor must be replaced.
- (e) Reconnect the No. 2 motor temperature sensor connector.

HV

OK

REPLACE HYBRID VEHICLE MOTOR ASSEMBLY

NG

6 READ VALUE OF INTELLIGENT TESTER (CHECK FOR GND SHORT IN HYBRID VEHICLE CONTROL ECU)

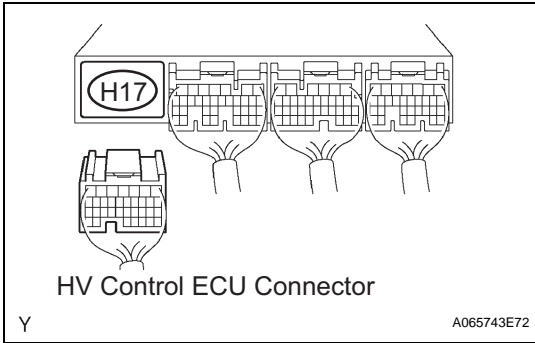

- (a) Disconnect the H17 HV control ECU connector.
- (b) Turn the power switch ON (IG).

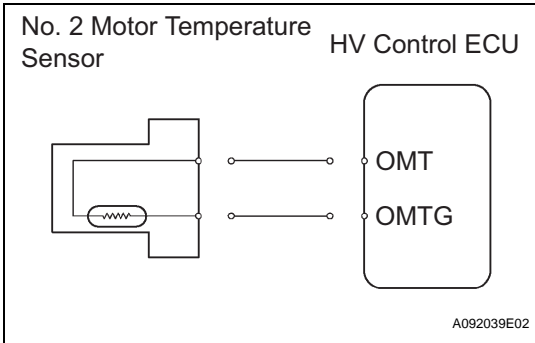

- (c) Enter the following menus: DIAGNOSIS / OBD/MOBD / HV ECU / DATA LIST.
- (d) Read the MOTOR 2 TEMP value.
OK:
-50°C (-58°F)
- (e) Reconnect the HV control ECU connector.

NG

REPLACE HYBRID VEHICLE CONTROL ECU

OK

HV

REPAIR OR REPLACE HARNESS OR CONNECTOR

DTC	P0A3F-243	Drive Motor "A" Position Sensor Circuit
DTC	P0A40-500	Drive Motor "A" Position Sensor Circuit Range / Performance
DTC	P0A41-245	Drive Motor "A" Position Sensor Circuit Low

DESCRIPTION

The motor resolver is a type of sensor that detects the position of the magnetic poles, which are indispensable for ensuring the highly efficient control of the MG1 and MG2.

The stator of the resolver contains an excitation coil and two detection coils. Because the rotor has an oval shape, the gap between the stator and the rotor changes as the rotor turns. An alternating current with a predetermined frequency flows through the excitation coil, and detection coils S and C output alternating currents in accordance with the position of the sensor rotor.

The HV control ECU detects the absolute position of the rotor in accordance with the phases of detection coils S and C and the height of their waveform. Furthermore, the CPU calculates the amount of change in the position within a predetermined length of time, in order to use the resolver as a speed sensor.

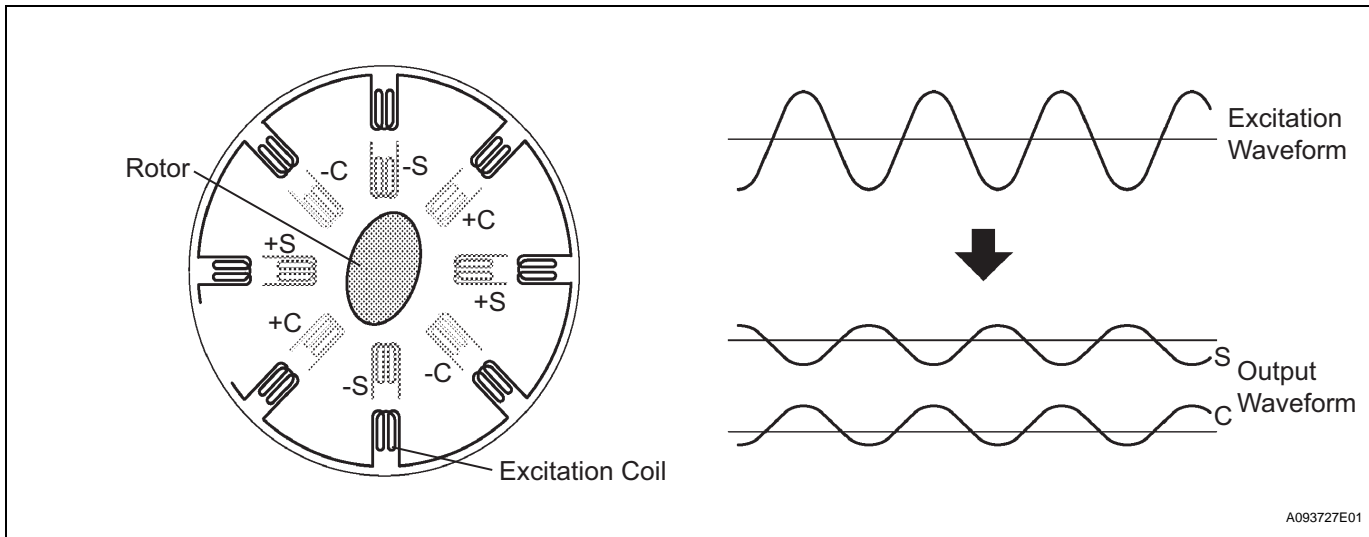

A09372E01

The HV control ECU monitors the output signals of the motor resolver and detects a malfunction.

DTC No.	INF Code	DTC Detection Condition	Trouble Area
P0A3F	243	Interphase short in motor resolver circuit	<ul style="list-style-type: none"> • Wire harness or connector • Hybrid vehicle motor • HV control ECU
P0A40	500	Motor resolver output is out of normal range	<ul style="list-style-type: none"> • Wire harness or connector • Hybrid vehicle motor • HV control ECU
P0A41	245	Open or short in motor resolver circuit	<ul style="list-style-type: none"> • Wire harness or connector • Hybrid vehicle motor • HV control ECU

MONITOR DESCRIPTION

The HV control ECU monitors the motor resolver output signal. If the HV control ECU detects output signals that are out of the normal range or specification, it will conclude that there is a malfunction of the motor resolver. The HV control ECU will illuminate the MIL and set a DTC.

HV

MONITOR STRATEGY

Related DTCs	P0A3F (INF 243): Drive motor "A" position sensor circuit malfunction / Short circuit between phases P0A40 (INF 500): Drive motor "A" position sensor circuit malfunction / Range check P0A41 (INF 245): Drive motor "A" position sensor circuit malfunction / Circuit discontinuity or short circuit
Required sensor / components	Motor resolver
Frequency of operation	Continuous
Duration	TOYOTA's intellectual property
MIL operation	Immediately
Sequence of operation	None

TYPICAL ENABLING CONDITIONS

The monitor will run whenever the following DTCs are not present	TOYOTA's intellectual property
No other condition	-

TYPICAL MALFUNCTION THRESHOLDS

Motor resolver	Circuit malfunction (interphase shot, open or short), or abnormal output
----------------	--

COMPONENT OPERATING RANGE

Motor resolver	DTCs P0A3F (INF 243), P0A40 (INF 500) and P0A41 (INF 245) are not detected
----------------	--

WIRING DIAGRAM

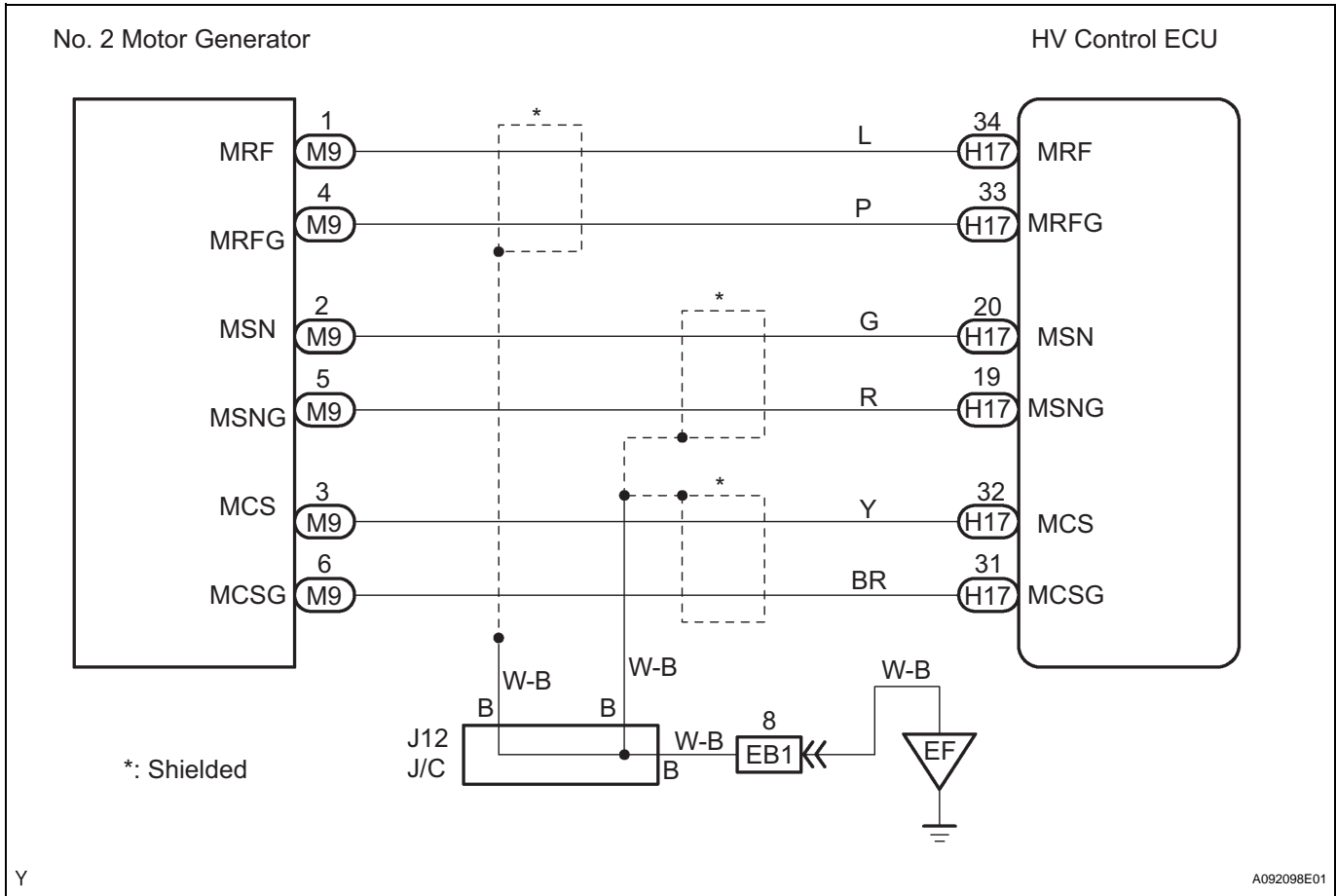

HV

INSPECTION PROCEDURE

- CHECK HARNESS AND CONNECTOR (HYBRID VEHICLE CONTROL ECU - MOTOR RESOLVER)**

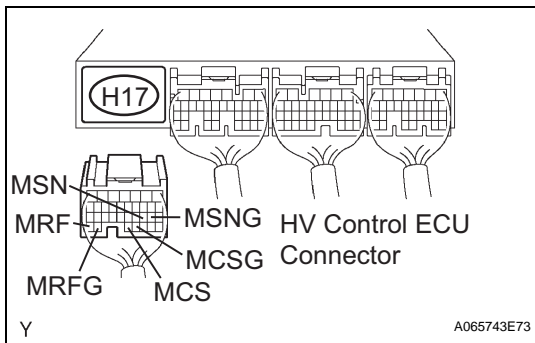

(a) Disconnect the H17 HV control ECU connector.

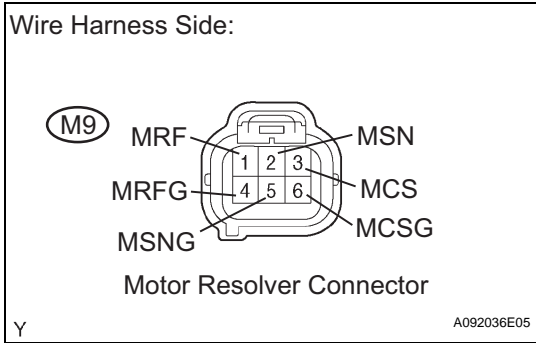

- (b) Disconnect the M9 motor resolver connector.
- (c) Turn the power switch ON (IG).
- (d) Measure the voltage between the terminals of the HV control ECU connector and body ground.

Standard voltage

Tester Connection	Specified Condition
MRF (H17-34) - Body ground	Below 1 V
MRFG (H17-33) - Body ground	Below 1 V
MSN (H17-20) - Body ground	Below 1 V
MSNG (H17-19) - Body ground	Below 1 V
MCS (H17-32) - Body ground	Below 1 V
MCSG (H17-31) - Body ground	Below 1 V

- (e) Turn the power switch OFF.
- (f) Measure the resistance between the wire harness side connectors.

Standard resistance (Check for open)

Tester Connection	Specified Condition
MRF (H17-34) - MRF (M9-1)	Below 1 Ω
MRFG (H17-33) - MRFG (M9-4)	Below 1 Ω
MSN (H17-20) - MSN (M9-2)	Below 1 Ω
MSNG (H17-19) - MSNG (M9-5)	Below 1 Ω
MCS (H17-32) - MCS (M9-3)	Below 1 Ω
MCSG (H17-31) - MCSG (M9-6)	Below 1 Ω

Standard resistance (Check for short)

Tester Connection	Specified Condition
MRF (H17-34) or MRF (M9-1) - Body ground	10 kΩ or higher
MRFG (H17-33) or MRFG (M9-4) - Body ground	10 kΩ or higher
MSN (H17-20) or MSN (M9-2) - Body ground	10 kΩ or higher
MSNG (H17-19) or MSNG (M9-5) - Body ground	10 kΩ or higher
MCS (H17-32) or MCS (M9-3) - Body ground	10 kΩ or higher
MCSG (H17-31) or MCSG (M9-6) - Body ground	10 kΩ or higher

- (g) Reconnect the motor resolver connector.
- (h) Reconnect the HV control ECU connector.

NG	REPAIR OR REPLACE HARNESS OR CONNECTOR
-----------	---

OK

HV

2 INSPECT MOTOR RESOLVER

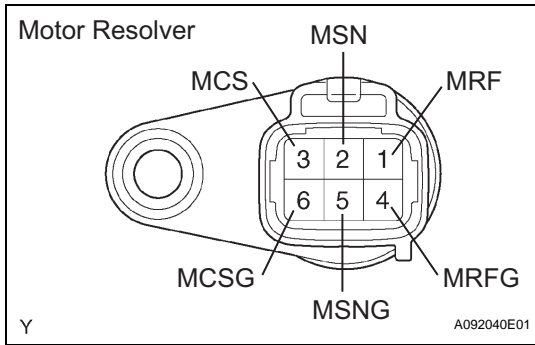

- (a) Disconnect the M9 motor resolver connector.
- (b) Measure the resistance between the terminals of the motor resolver.

Standard resistance

Tester Connection	Specified Condition
MRF (M9-1) - MRFG (M9-4)	7.65 to 10.2 Ω
MSN (M9-2) - MSNG (M9-5)	12.6 to 16.8 Ω
MCS (M9-3) - MCSG (M9-6)	12.6 to 16.8 Ω

- (c) Using a megohmmeter, measure the insulation resistance between the terminals of the motor resolver.

Standard resistance

Tester Connection	Specified Condition
MRF (M9-1) - MSN (M9-2)	10 MΩ or higher
MRF (M9-1) - MCS (M9-3)	10 MΩ or higher
MSN (M9-2) - MCS (M9-3)	10 MΩ or higher
MRFG (M9-4) - MSNG (M9-5)	10 MΩ or higher
MRFG (M9-4) - MCSG (M9-6)	10 MΩ or higher
MSNG (M9-5) - MCSG (M9-6)	10 MΩ or higher
Each terminal listed above - Transaxle housing	10 MΩ or higher

NG → **REPLACE HYBRID VEHICLE MOTOR ASSEMBLY**

OK

REPLACE HYBRID VEHICLE CONTROL ECU

DTC	P0A4B-253	Generator Position Sensor Circuit
DTC	P0A4C-513	Generator Position Sensor Circuit Range / Performance
DTC	P0A4D-255	Generator Position Sensor Circuit Low

DESCRIPTION

The generator resolver detects the position of the magnetic poles, which are indispensable for ensuring the highly efficient control of the MG1 and MG2. The construction of the generator resolver and how it is connected to the HV control ECU are the same as those of the motor resolver (see page [HV-200](#)).

DTC No.	INF Code	DTC Detection Condition	Trouble Area
P0A4B	253	Interphase short in generator resolver circuit	<ul style="list-style-type: none"> Wire harness or connector Hybrid vehicle generator HV control ECU
P0A4C	513	Generator resolver output is out of normal range	<ul style="list-style-type: none"> Wire harness or connector Hybrid vehicle generator HV control ECU
P0A4D	255	Open or short in generator resolver circuit	<ul style="list-style-type: none"> Wire harness or connector Hybrid vehicle generator HV control ECU

MONITOR DESCRIPTION

The HV control ECU monitors the generator resolver output signal. If the HV control ECU detects output signals that are out of the normal range or specification, it will conclude that there is a malfunction of the generator resolver. The HV control ECU will illuminate the MIL and set a DTC.

HV

MONITOR STRATEGY

Related DTCs	P0A4B (INF 253): Generator position sensor circuit malfunction / Short circuit between phases P0A4C (INF 513): Generator position sensor circuit malfunction / Range check P0A4D (INF 255): Generator position sensor circuit malfunction / Circuit discontinuity or short circuit
Required sensor / components	Generator resolver
Frequency of operation	Continuous
Duration	TOYOTA's intellectual property
MIL operation	Immediately
Sequence of operation	None

TYPICAL ENABLING CONDITIONS

The monitor will run whenever the following DTCs are not present	TOYOTA's intellectual property
No other condition	-

TYPICAL MALFUNCTION THRESHOLDS

Generator resolver	Circuit malfunction (interphase shot, open or short), or abnormal output
--------------------	--

COMPONENT OPERATING RANGE

Generator resolver	DTCs P0A4B (INF 253) P0A4C (INF 513) and P0A4D (INF 255) are not detected
--------------------	---

WIRING DIAGRAM

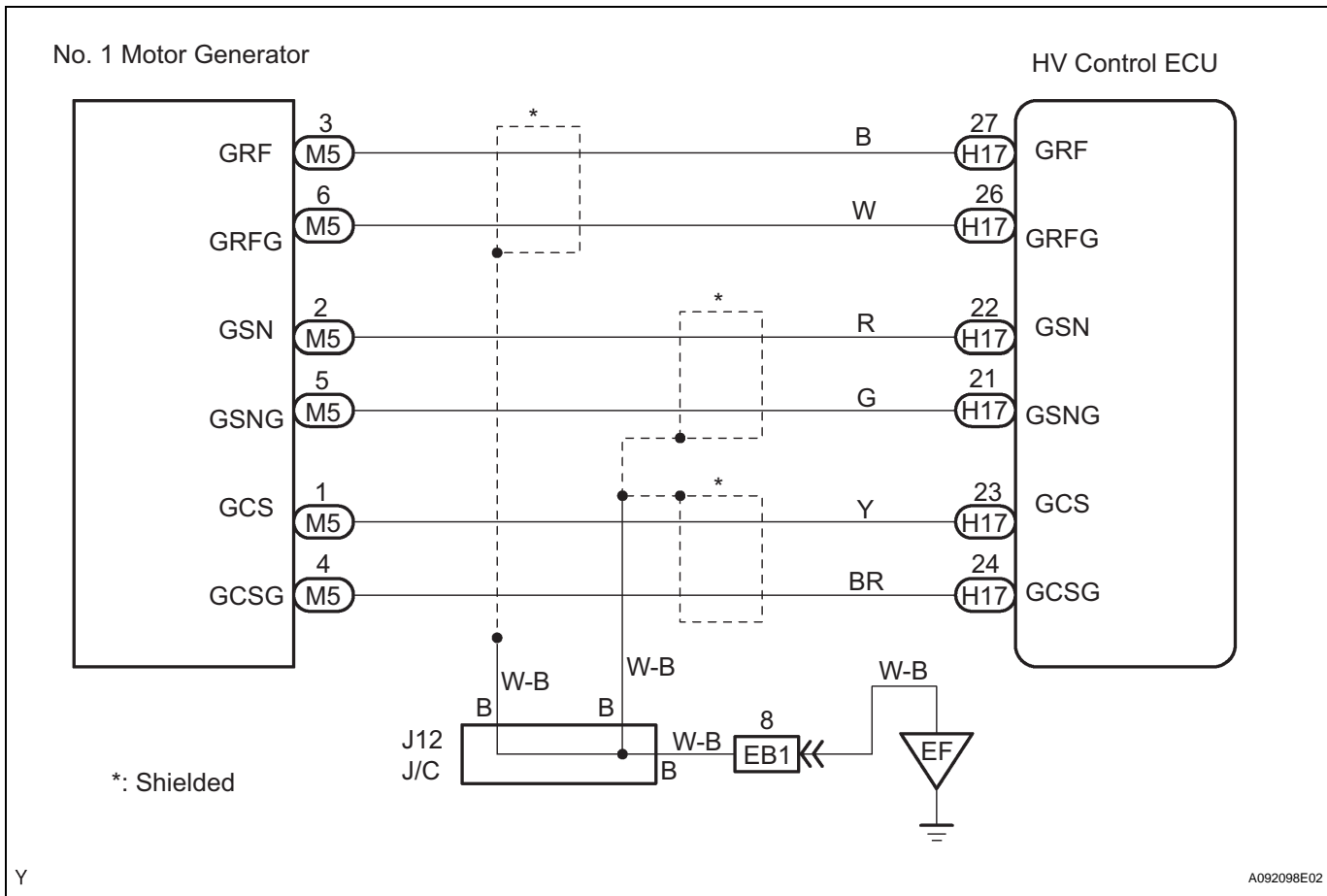

INSPECTION PROCEDURE

1 CHECK HARNESS AND CONNECTOR (HYBRID VEHICLE CONTROL ECU - GENERATOR RESOLVER)

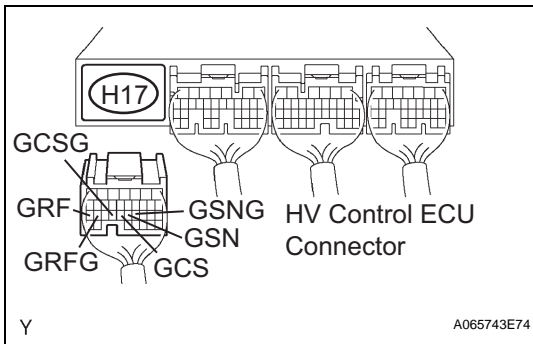

(a) Disconnect the H17 HV control ECU connector.

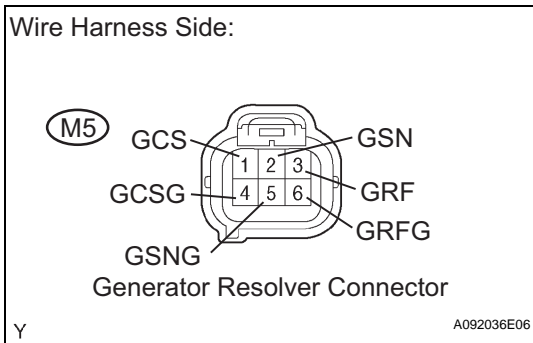

(b) Disconnect the M5 generator resolver connector.

(c) Turn the power switch ON (IG).

(d) Measure the voltage between the terminals of the HV control ECU connector and body ground.

Standard voltage

Tester Connection	Specified Condition
GRF (H17-27) - Body ground	Below 1 V
GRFG (H17-26) - Body ground	Below 1 V
GSN (H17-22) - Body ground	Below 1 V
GSNG (H17-21) - Body ground	Below 1 V
GCS (H17-23) - Body ground	Below 1 V
GCSG (H17-24) - Body ground	Below 1 V

(e) Turn the power switch OFF.

(f) Measure the resistance between the wire harness side connectors.

Standard resistance (Check for open)

Tester Connection	Specified Condition
GRF (H17-27) - GRF (M5-3)	Below 1 Ω
GRFG (H17-26) - GRFG (M5-6)	Below 1 Ω
GSN (H17-22) - GSN (M5-2)	Below 1 Ω
GSNG (H17-21) - GSNG (M5-5)	Below 1 Ω
GCS (H17-23) - GCS (M5-1)	Below 1 Ω
GCSG (H17-24) - GCSG (M5-4)	Below 1 Ω

Standard resistance (Check for short)

Tester Connection	Specified Condition
GRF (H17-27) or GRF (M5-3) - Body ground	10 kΩ or higher
GRFG (H17-26) or GRFG (M5-6) - Body ground	10 kΩ or higher
GSN (H17-22) or GSN (M5-2) - Body ground	10 kΩ or higher
GSNG (H17-21) or GSNG (M5-5) - Body ground	10 kΩ or higher
GCS (H17-23) or GCS (M5-1) - Body ground	10 kΩ or higher

Tester Connection	Specified Condition
GCSG (H17-24) or GCSG (M5-4) - Body ground	10 kΩ or higher

- (g) Reconnect the generator resolver connector.
- (h) Reconnect the HV control ECU connector.

NG → **REPAIR OR REPLACE HARNESS OR CONNECTOR**

OK

2 INSPECT GENERATOR RESOLVER

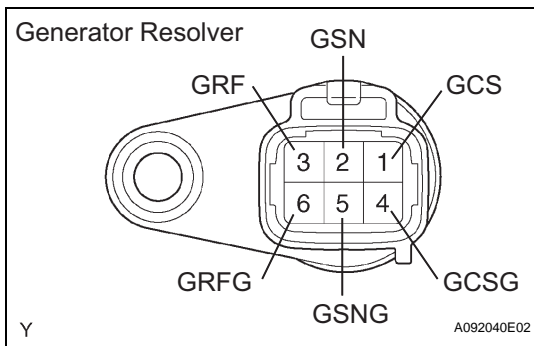

- (a) Disconnect the M5 generator resolver connector.
- (b) Measure the resistance between the terminals of the generator resolver.

Standard resistance

Tester Connection	Specified Condition
GCS (M5-1) - GCSG (M5-4)	12.6 to 16.8 Ω
GSN (M5-2) - GSNG (M5-5)	12.6 to 16.8 Ω
GRF (M5-3) - GRFG (M5-6)	7.65 to 10.2 Ω

- (c) Using a megohmmeter, measure the insulation resistance between the terminals of the generator resolver.

Standard resistance

Tester Connection	Specified Condition
GCS (M5-1) - GSN (M5-2)	10 MΩ or higher
GCS (M5-1) - GRF (M5-3)	10 MΩ or higher
GSN (M5-2) - GRF (M5-3)	10 MΩ or higher
GCSG (M5-4) - GSNG (M5-5)	10 MΩ or higher
GCSG (M5-4) - GRFG (M5-6)	10 MΩ or higher
GSNG (M5-5) - GRFG (M5-6)	10 MΩ or higher
Each terminal listed above - Transaxle housing	10 MΩ or higher

NG → **REPLACE HYBRID VEHICLE GENERATOR ASSEMBLY**

OK

REPLACE HYBRID VEHICLE CONTROL ECU

HV

DTC	P0A51- 174	Drive Motor "A" Current Sensor Circuit
------------	-----------------------	---

DESCRIPTION

The HV control performs self-checks to detect an internal operating malfunction in the ECU.

DTC No.	INF Code	DTC Detection Condition	Trouble Area
P0A51	174	HV control ECU internal error	<ul style="list-style-type: none"> • HV control ECU

INSPECTION PROCEDURE

If the information (INF) code is present, replace the HV control ECU.

1	REPLACE HYBRID VEHICLE CONTROL ECU
----------	---

- (a) Replace the hybrid vehicle control ECU (see page [HV-543](#)).

NEXT

COMPLETED

DTC	P0A60-288	Drive Motor "A" Phase V Current
DTC	P0A60-289	Drive Motor "A" Phase V Current
DTC	P0A60-290	Drive Motor "A" Phase V Current
DTC	P0A60-292	Drive Motor "A" Phase V Current
DTC	P0A60-294	Drive Motor "A" Phase V Current
DTC	P0A60-501	Drive Motor "A" Phase V Current
DTC	P0A63-296	Drive Motor "A" Phase W Current
DTC	P0A63-297	Drive Motor "A" Phase W Current
DTC	P0A63-298	Drive Motor "A" Phase W Current
DTC	P0A63-300	Drive Motor "A" Phase W Current
DTC	P0A63-302	Drive Motor "A" Phase W Current
DTC	P0A63-502	Drive Motor "A" Phase W Current

DESCRIPTION

See the description of the inverter (see page [HV-220](#)).

The motor inverter current sensors detect the amperage that flows through the V and W phase cables between the inverter and MG1/MG2. The inverter transmits information that is necessary for effecting control, such as the amperage and voltage, to the HV control ECU.

The HV control ECU monitors the inverter current sensors to detect a malfunction in the sensor system.

It does not detect malfunctions in the high voltage system.

DTC No.	INF Code	DTC Detection Condition	Trouble Area
P0A60	288	Phase V current sub sensor of motor inverter current sensor malfunction	<ul style="list-style-type: none"> Wire harness or connector Inverter with converter assembly
P0A60	289	Open in phase V current sub sensor circuit of motor inverter current sensor	<ul style="list-style-type: none"> Wire harness or connector Inverter with converter assembly
P0A60	290	Phase V current main sensor of motor inverter current sensor malfunction	<ul style="list-style-type: none"> Wire harness or connector Inverter with converter assembly
P0A60	292	Open in phase V current main sensor circuit of motor inverter current sensor	<ul style="list-style-type: none"> Wire harness or connector Inverter with converter assembly
P0A60	294	Phase V current main and sub sensors of motor inverter current sensor performance problem	<ul style="list-style-type: none"> Wire harness or connector Inverter with converter assembly
P0A60	501	Phase V current main and sub sensors of motor inverter current sensor offset malfunction	<ul style="list-style-type: none"> Wire harness or connector Inverter with converter assembly
P0A63	296	Phase W current sub sensor of motor inverter current sensor malfunction	<ul style="list-style-type: none"> Wire harness or connector Inverter with converter assembly
P0A63	297	Open in phase W current sub sensor circuit of motor inverter current sensor	<ul style="list-style-type: none"> Wire harness or connector Inverter with converter assembly
P0A63	298	Phase W current main sensor of motor inverter current sensor malfunction	<ul style="list-style-type: none"> Wire harness or connector Inverter with converter assembly
P0A63	300	Open in phase W current main sensor circuit of motor inverter current sensor	<ul style="list-style-type: none"> Wire harness or connector Inverter with converter assembly
P0A63	302	Phase W current main and sub sensors of motor inverter current sensor performance problem	<ul style="list-style-type: none"> Wire harness or connector Inverter with converter assembly
P0A63	502	Phase W current main and sub sensors of motor inverter current sensor offset malfunction	<ul style="list-style-type: none"> Wire harness or connector Inverter with converter assembly

MONITOR DESCRIPTION

The HV control ECU monitors the motor inverter current sensor. If the HV control ECU detects a fault, it will illuminate the MIL and set a DTC.

MONITOR STRATEGY

Related DTCs	P0A60 (INF 288 / 289 / 290 / 292 / 294 / 501): Motor inverter current sensor / Phase V current sensor malfunction P0A63 (INF 296 / 297 / 298 / 300 / 302 / 502): Motor inverter current sensor / Phase W current sensor malfunction
Required sensor / components	Motor inverter current sensor, motor resolver
Frequency of operation	Continuous
Duration	TOYOTA's intellectual property
MIL operation	Immediately
Sequence of operation	None

TYPICAL ENABLING CONDITIONS

The monitor will run whenever the following DTCs are not present	TOYOTA's intellectual property
--	--------------------------------

Other conditions belong to TOYOTA's intellectual property	-
---	---

TYPICAL MALFUNCTION THRESHOLDS

TOYOTA's intellectual property	-
--------------------------------	---

COMPONENT OPERATING RANGE

P0A60 (INF 288 / 289 / 290 / 292 / 294 / 501):

Motor inverter current sensor	DTC P0A60 (INF 288 / 289 / 290 / 292 / 294 / 501) is not detected
-------------------------------	---

P0A63 (INF 296 / 297 / 298 / 300 / 302 / 502):

Motor inverter current sensor	DTC P0A63 (INF 296 / 297 / 298 / 300 / 302 / 502) is not detected
-------------------------------	---

WIRING DIAGRAM

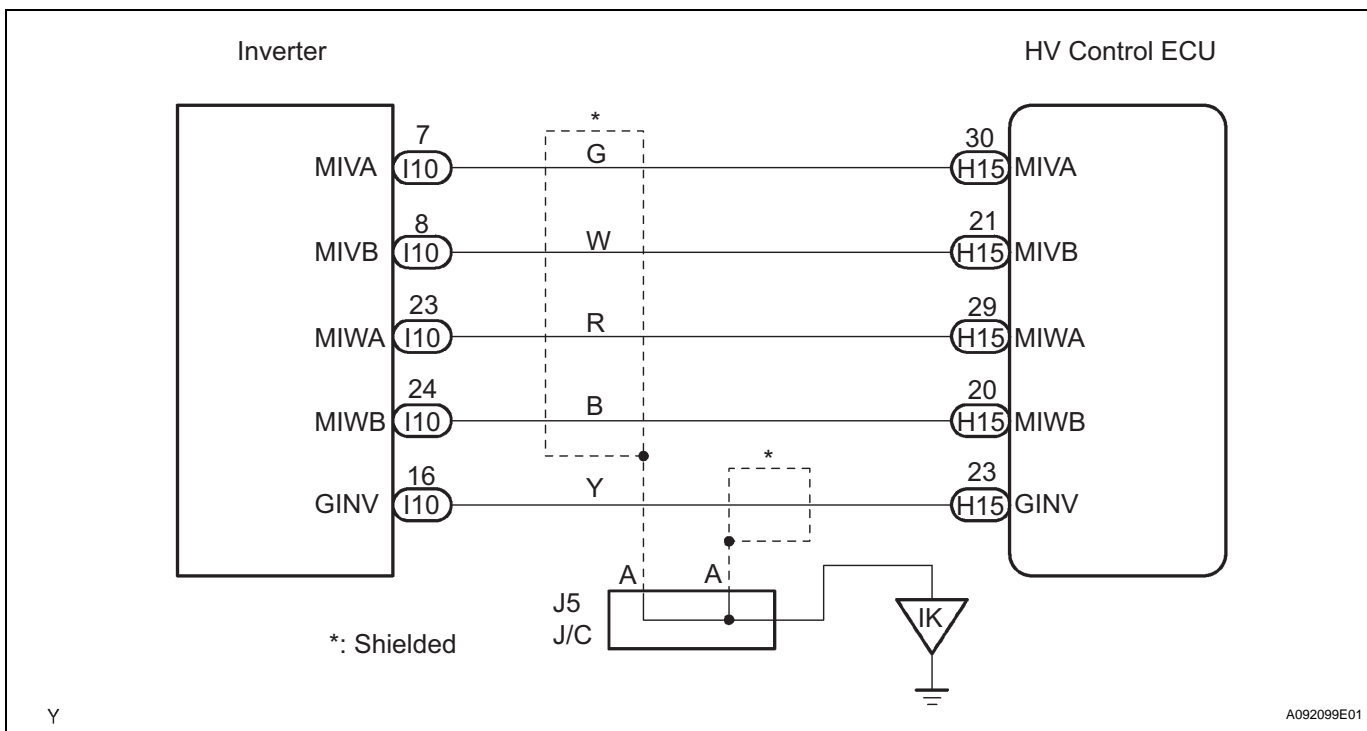

INSPECTION PROCEDURE

CAUTION:

- Before inspecting the high-voltage system, take safety precautions to prevent electrical shocks, such as wearing insulated gloves and removing the service plug grip. After removing the service plug grip, put it in your pocket to prevent other technicians from reconnecting it while you are servicing the high-voltage system.
- After disconnecting the service plug grip, wait for at least 5 minutes before touching any of the high-voltage connectors or terminals.

HINT:

At least 5 minutes are required to discharge the high-voltage condenser inside the inverter.

HV

1 CHECK HARNESS AND CONNECTOR (HYBRID VEHICLE CONTROL ECU - INVERTER)

CAUTION:

Wear insulated gloves before performing the following operation.

- (a) Turn the power switch OFF.
- (b) Remove the service plug grip (see page [HB-154](#)).

NOTICE:

Turning the power switch ON (READY) with the service plug grip removed could cause malfunction. Therefore, never turn the power switch ON (READY) in this state.

- (c) Disconnect the H15 HV control ECU connector.
- (d) Remove the inverter cover (see page [HV-531](#)).

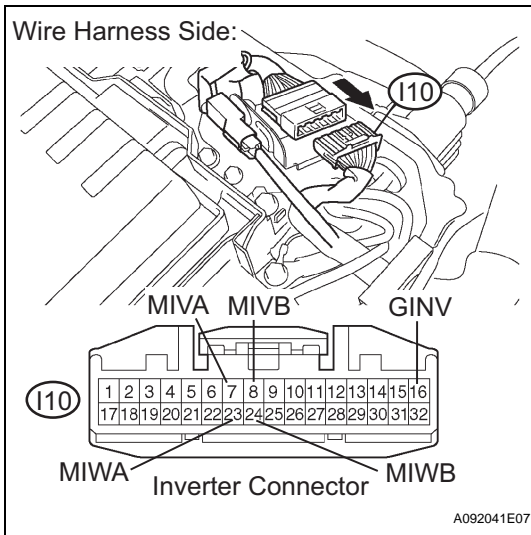
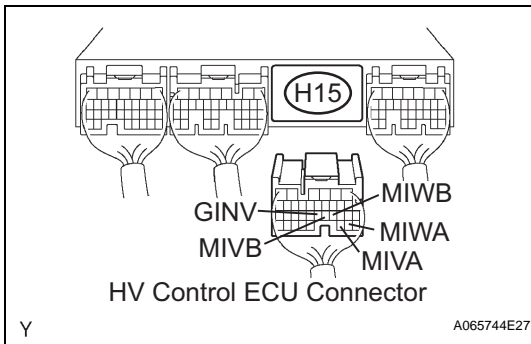

- (e) Disconnect the I10 inverter connector.
- (f) Turn the power switch ON (IG).

HINT:

DTCs for the interlock switch system are output when turning the power switch ON (IG) with both service plug grip and inverter cover removed.

- (g) Measure the voltage between the terminals of the HV control ECU connector and body ground.

Standard voltage

Tester Connection	Specified Condition
MIVA (H15-30) - Body ground	Below 1 V
MIVB (H15-21) - Body ground	Below 1 V
MIWA (H15-29) - Body ground	Below 1 V
MIWB (H15-20) - Body ground	Below 1 V
GINV (H15-23) - Body ground	Below 1 V

- (h) Turn the power switch OFF.
- (i) Measure the resistance between the wire harness side connectors.

Standard resistance (Check for open)

Tester Connection	Specified Condition
MIVA (H15-30) - MIVA (I10-7)	Below 1 Ω
MIVB (H15-21) - MIVB (I10-8)	Below 1 Ω
MIWA (H15-29) - MIWA (I10-23)	Below 1 Ω
MIWB (H15-20) - MIWB (I10-24)	Below 1 Ω
GINV (H15-23) - GINV (I10-16)	Below 1 Ω

Standard resistance (Check for short)

Tester Connection	Specified Condition
MIVA (H15-30) or MIVA (I10-7) - Body ground	10 kΩ or higher
MIVB (H15-21) or MIVB (I10-8) - Body ground	10 kΩ or higher
MIWA (H15-29) or MIWA (I10-23) - Body ground	10 kΩ or higher
MIWB (H15-20) or MIWB (I10-24) - Body ground	10 kΩ or higher
GINV (H15-23) or GINV (I10-16) - Body ground	10 kΩ or higher

- (j) Reconnect the inverter connector.
- (k) Reconnect the HV control ECU connector.
- (l) Reinstall the inverter cover (see page [HV-538](#)).
- (m) Reinstall the service plug grip (see page [HB-154](#)).

NG **REPAIR OR REPLACE HARNESS OR CONNECTOR**

OK

REPLACE INVERTER WITH CONVERTER ASSEMBLY

DTC	P0A72-326	Generator Phase V Current
DTC	P0A72-327	Generator Phase V Current
DTC	P0A72-328	Generator Phase V Current
DTC	P0A72-330	Generator Phase V Current
DTC	P0A72-333	Generator Phase V Current
DTC	P0A72-515	Generator Phase V Current
DTC	P0A75-334	Generator Phase W Current
DTC	P0A75-335	Generator Phase W Current
DTC	P0A75-336	Generator Phase W Current
DTC	P0A75-338	Generator Phase W Current
DTC	P0A75-341	Generator Phase W Current
DTC	P0A75-516	Generator Phase W Current

DESCRIPTION

Refer to DTC P0A60 (INF 288) (see page [HV-210](#)).

DTC No.	INF Code	DTC Detection Condition	Trouble Area
P0A72	326	Phase V current sub sensor of generator inverter current sensor malfunction	<ul style="list-style-type: none"> • Wire harness or connector • Inverter with converter assembly

DTC No.	INF Code	DTC Detection Condition	Trouble Area
P0A72	327	Open in phase V current sub sensor circuit of generator inverter current sensor	<ul style="list-style-type: none"> Wire harness or connector Inverter with converter assembly
P0A72	328	Phase V current main sensor of generator inverter current sensor malfunction	<ul style="list-style-type: none"> Wire harness or connector Inverter with converter assembly
P0A72	330	Open in phase V current main sensor circuit of generator inverter current sensor	<ul style="list-style-type: none"> Wire harness or connector Inverter with converter assembly
P0A72	333	Phase V current main and sub sensors of generator inverter current sensor performance problem	<ul style="list-style-type: none"> Wire harness or connector Inverter with converter assembly
P0A72	515	Phase V current main and sub sensors of generator inverter current sensor offset malfunction	<ul style="list-style-type: none"> Wire harness or connector Inverter with converter assembly
P0A75	334	Phase W current sub sensor of generator inverter current sensor malfunction	<ul style="list-style-type: none"> Wire harness or connector Inverter with converter assembly
P0A75	335	Open in phase W current sub sensor circuit of generator inverter current sensor	<ul style="list-style-type: none"> Wire harness or connector Inverter with converter assembly
P0A75	336	Phase W current main sensor of generator inverter current sensor malfunction	<ul style="list-style-type: none"> Wire harness or connector Inverter with converter assembly
P0A75	338	Open in phase W current main sensor circuit of generator inverter current sensor	<ul style="list-style-type: none"> Wire harness or connector Inverter with converter assembly
P0A75	341	Phase W current main and sub sensors of generator inverter current sensor performance problem	<ul style="list-style-type: none"> Wire harness or connector Inverter with converter assembly
P0A75	516	Phase W current main and sub sensors of generator inverter current sensor offset malfunction	<ul style="list-style-type: none"> Wire harness or connector Inverter with converter assembly

MONITOR DESCRIPTION

The HV control ECU monitors the generator inverter current sensor. If the HV control ECU detects a fault, it will illuminate the MIL and set a DTC.

MONITOR STRATEGY

Related DTCs	P0A72 (INF 326 / 327 / 328 / 330 / 333 / 515): Generator inverter current sensor / Phase V current sensor malfunction P0A75 (INF 334 / 335 / 336 / 338 / 341 / 516): Generator inverter current sensor / Phase W current sensor malfunction
Required sensor / components	Generator inverter current sensor, generator resolver
Frequency of operation	Continuous
Duration	TOYOTA's intellectual property
MIL operation	Immediately
Sequence of operation	None

TYPICAL ENABLING CONDITIONS

The monitor will run whenever the following DTCs are not present	TOYOTA's intellectual property
Other conditions belong to TOYOTA's intellectual property	-

TYPICAL MALFUNCTION THRESHOLDS

TOYOTA's intellectual property	-
--------------------------------	---

COMPONENT OPERATING RANGE

P0A72 (INF 326 / 327 / 328 / 330 / 333 / 515):

Generator inverter current sensor	DTC P0A72 (INF 326 / 327 / 328 / 330 / 333 / 515) is not detected
-----------------------------------	---

P0A75 (INF 334 / 335 / 336 / 338 / 341 / 516):

Generator inverter current sensor	DTC P0A75 (INF 334 / 335 / 336 / 338 / 341 / 516) is not detected
-----------------------------------	---

WIRING DIAGRAM

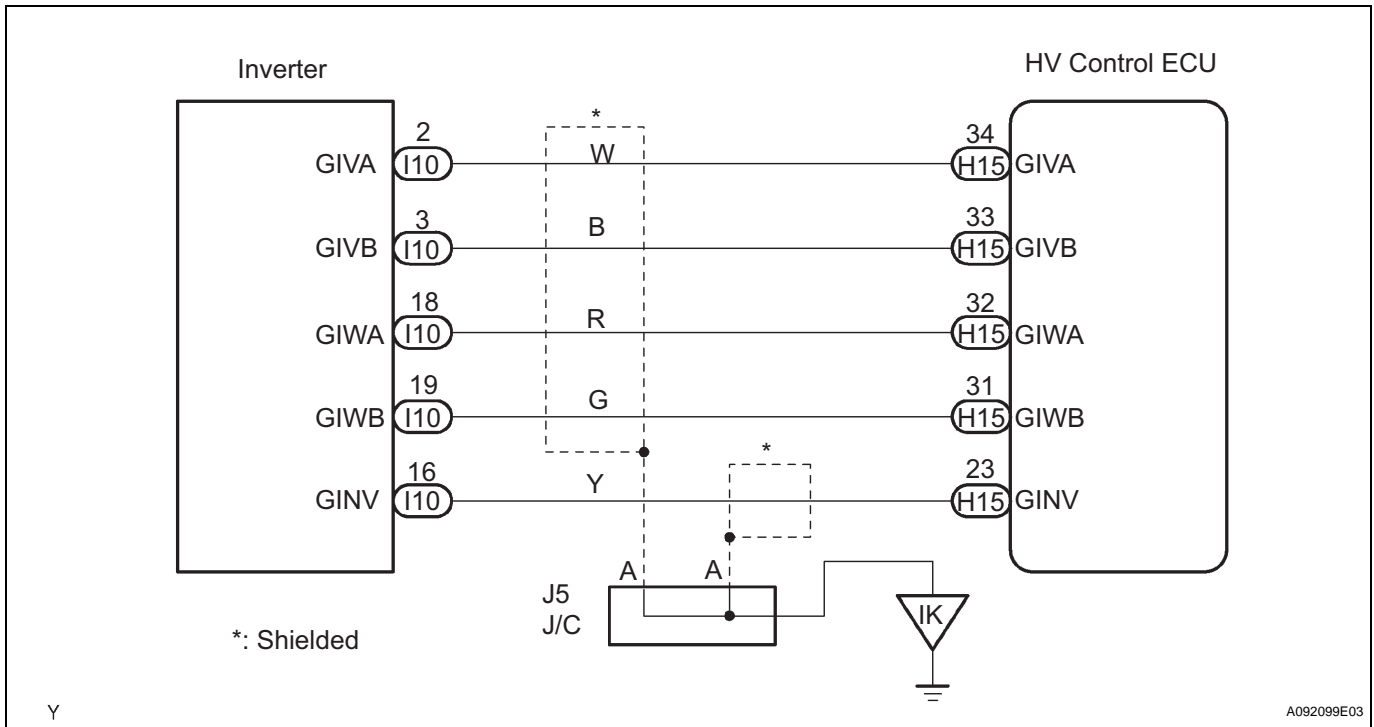

HV

INSPECTION PROCEDURE

CAUTION:

- Before inspecting the high-voltage system, take safety precautions to prevent electrical shocks, such as wearing insulated gloves and removing the service plug grip. After removing the service plug grip, put it in your pocket to prevent other technicians from reconnecting it while you are servicing the high-voltage system.
- After disconnecting the service plug grip, wait for at least 5 minutes before touching any of the high-voltage connectors or terminals.

HINT:

At least 5 minutes are required to discharge the high-voltage condenser inside the inverter.

1	CHECK HARNESS AND CONNECTOR (HYBRID VEHICLE CONTROL ECU - INVERTER)
----------	--

NOTICE:

Wear insulated gloves before performing the following operation.

- (a) Turn the power switch OFF.

- (b) Remove the service plug grip (see page [HB-154](#)).
NOTICE:
Turning the power switch ON (READY) with the service plug grip removed could cause malfunction. Therefore, never turn the power switch ON (READY) in this state.
- (c) Disconnect the H15 HV control ECU connector.
- (d) Remove the inverter cover (see page [HV-531](#)).

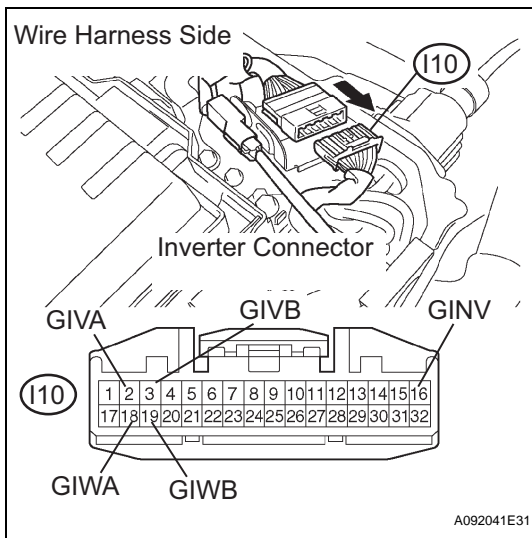
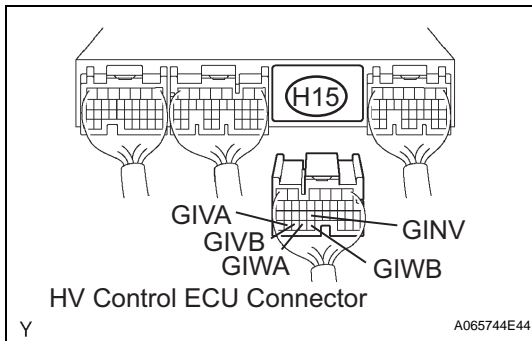

- (e) Disconnect the I10 inverter connector.
- (f) Turn the power switch ON (IG).
HINT:
 DTCs for the interlock switch system are output when turning the power switch ON (IG) with both service plug grip and inverter cover removed.
- (g) Measure the voltage between the terminals of the HV control ECU connector and body ground.

Standard voltage

Tester Connection	Specified Condition
GIVA (H15-34) - Body ground	Below 1 V
GIVB (H15-33) - Body ground	Below 1 V
GIWA (H15-32) - Body ground	Below 1 V
GIWB (H15-31) - Body ground	Below 1 V
GINV (H15-23) - Body ground	Below 1 V

- (h) Turn the power switch OFF.
- (i) Measure the resistance between the wire harness side connectors.

Standard resistance (Check for open)

Tester Connection	Specified Condition
GIVA (H15-34) - GIVA (I10-2)	Below 1 Ω
GIVB (H15-33) - GIVB (I10-3)	Below 1 Ω
GIWA (H15-32) - GIWA (I10-18)	Below 1 Ω
GIWB (H15-31) - GIWB (I10-19)	Below 1 Ω
GINV (H15-23) - GINV (I10-16)	Below 1 Ω

Standard resistance (Check for short)

Tester Connection	Specified Condition
GIVA (H15-34) or GIVA (I10-2) - Body ground	10 kΩ or higher
GIVB (H15-33) or GIVB (I10-3) - Body ground	10 kΩ or higher
GIWA (H15-32) or GIWA (I10-18) - Body ground	10 kΩ or higher
GIWB (H15-31) or GIWB (I10-19) - Body ground	10 kΩ or higher

Tester Connection	Specified Condition
GINV (H15-23) or GINV (I10-16) - Body ground	10 k Ω or higher

- (j) Reconnect the inverter connector.
- (k) Reconnect the HV control ECU connector.
- (l) Reinstall the inverter cover (see page [HV-538](#)).
- (m) Reinstall the service plug grip (see page [HB-154](#)).

NG**REPAIR OR REPLACE HARNESS OR
CONNECTOR****OK****REPLACE INVERTER WITH CONVERTER ASSEMBLY**

DTC	P0A78-266	Drive Motor "A" Inverter Performance
DTC	P0A78-267	Drive Motor "A" Inverter Performance

DESCRIPTION

The inverter converts the high-voltage direct current of the HV battery and the alternating current for the MG1/MG2. The inverter contains a three-phase bridge circuit, which consists of 6 power transistors each for the MG1 and the MG2, in order to convert the direct current and the three-phase alternating current. The HV control ECU controls the actuation of the power transistors.

The inverter transmits information that is necessary for effecting control, such as the amperage and voltage, to the HV control ECU.

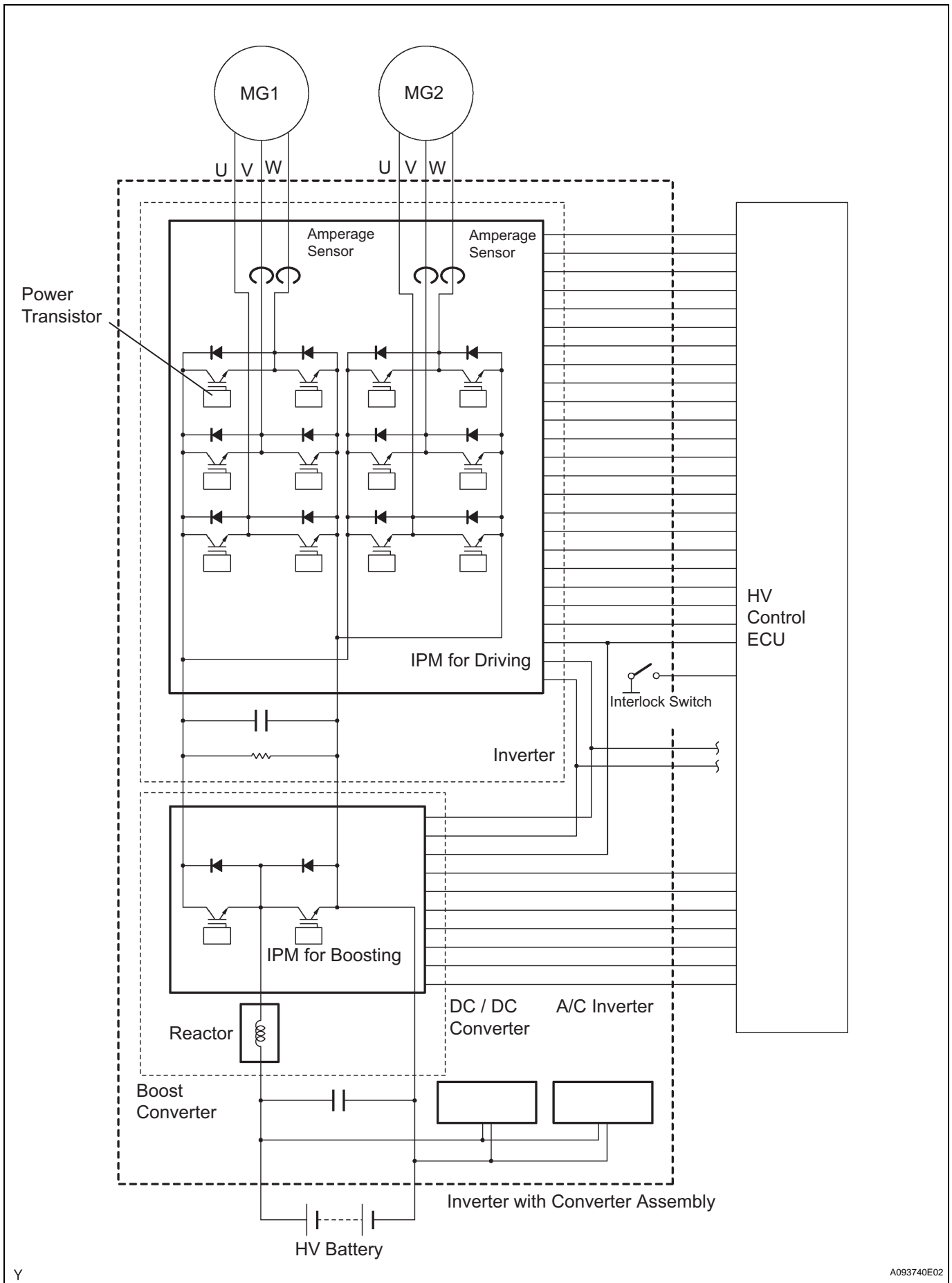

HV

The HV control ECU uses a voltage sensor, which has been built into the inverter, to detect the high voltage after boost control.

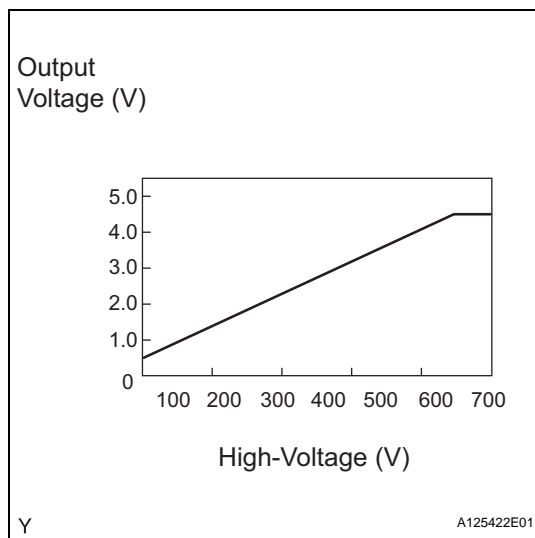

The inverter voltage sensor outputs a voltage that varies between 0 and 5 V in accordance with the changes in the high voltage. The higher the high voltage, the higher the output voltage, and the lower the high voltage, the lower the output voltage.

The HV control ECU monitors the inverter voltage and detects a malfunction.

DTC No.	INF Code	DTC Detection Condition	Trouble Area
P0A78	266	Open or GND short in inverter voltage (VH) sensor circuit	<ul style="list-style-type: none"> Wire harness or connector Inverter with converter assembly HV control ECU
P0A78	267	+B short in inverter voltage (VH) sensor circuit	<ul style="list-style-type: none"> Wire harness or connector Inverter with converter assembly HV control ECU

HV

HINT:

After confirming DTC P0A78 (INF 266 or 267), confirm VH in DIAGNOSIS / OBD/MOBD / HV ECU / DATA LIST using the intelligent tester.

Voltage Displayed	Malfunction
765 V	+B short circuit
0 V	Open or GND short circuit

MONITOR DESCRIPTION

The HV control ECU monitors the inverter voltage (VH) sensor circuit. If the HV control ECU detects an open or short malfunction of the VH sensor circuit, the HV control ECU illuminates the MIL and sets a DTC.

MONITOR STRATEGY

Related DTCs	P0A78 (INF 266 / 267): Motor inverter / VH malfunction
Required sensor / components	Motor inverter
Frequency of operation	Continuous
Duration	TOYOTA's intellectual property
MIL operation	1 driving cycle
Sequence of operation	None

TYPICAL ENABLING CONDITIONS

The monitor will run whenever the following DTCs are not present	TOYOTA's intellectual property
Other conditions belong to TOYOTA's intellectual property	-

TYPICAL MALFUNCTION THRESHOLDS

Voltage (VH) sensor circuit	Open or short
-----------------------------	---------------

COMPONENT OPERATING RANGE

Motor inverter	DTC P0A78 (INF 266 / 267) is not detected
----------------	---

WIRING DIAGRAM

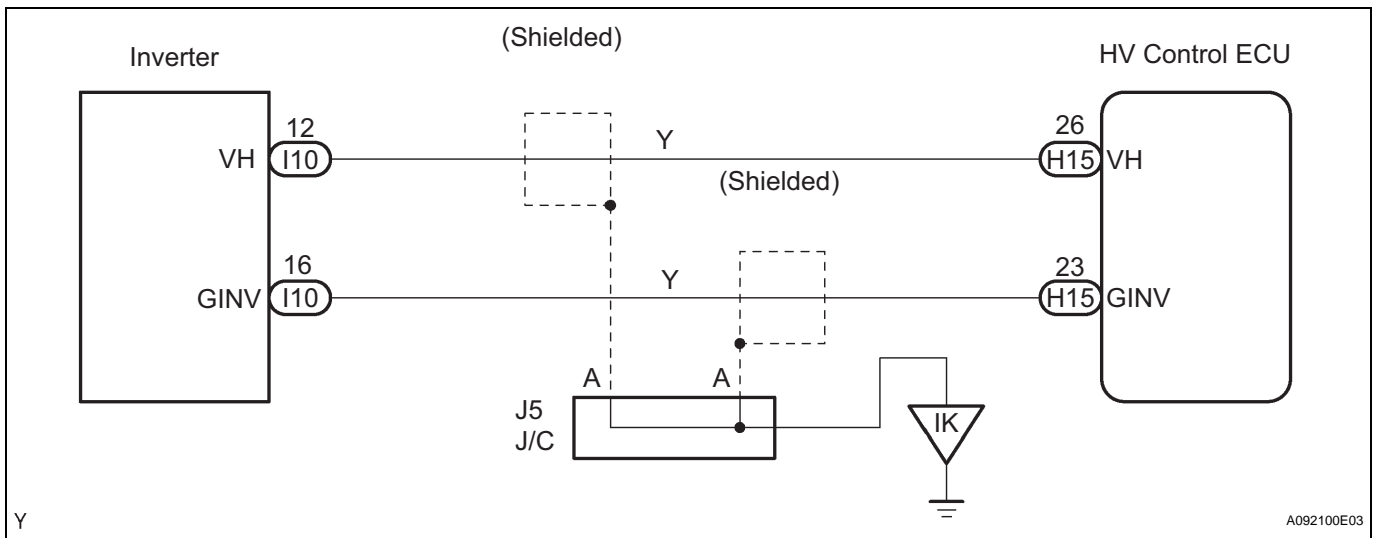

INSPECTION PROCEDURE

CAUTION:

- Before inspecting the high-voltage system, take safety precautions to prevent electrical shocks, such as wearing insulated gloves and removing the service plug grip. After removing the service plug grip, put it in your pocket to prevent other technicians from reconnecting it while you are servicing the high-voltage system.
- After disconnecting the service plug grip, wait for at least 5 minutes before touching any of the high-voltage connectors or terminals.

HINT:

At least 5 minutes are required to discharge the high-voltage condenser inside the inverter.

1	READ OUTPUT DTC (HV ECU)
----------	---------------------------------

- (a) Connect the intelligent tester to the DLC3.
- (b) Turn the power switch ON (IG).
- (c) Turn the intelligent tester ON.
- (d) Enter the following menus: DIAGNOSIS / OBD/MOBD / HV ECU / DTC INFO / CURRENT CODES.
- (e) Read DTCs.

Result:

DTC P0A1D is output

YES → **GO TO RELEVANT DTC CHART**

NO

2 READ VALUE OF INTELLIGENT TESTER (VH)

- (a) Connect the intelligent tester to the DLC3.
- (b) Turn the power switch ON (IG).
- (c) Turn the intelligent tester ON.
- (d) Enter the following menus: DIAGNOSIS / OBD/MOBD / HV ECU / DATA LIST.
- (e) Read the VH value.

Result:

Voltage Displayed	Proceed to
765 V	A
0 V	B
1 to 764 V	C

HINT:

- If there is a +B short circuit, the intelligent tester indicates 765 V.
- If there is an open or GND short circuit, the intelligent tester indicates 0 V.

B → **Go to step 5**

C → **CHECK FOR INTERMITTENT PROBLEMS**

A

3 READ VALUE OF INTELLIGENT TESTER (CHECK FOR +B SHORT IN WIRE HARNESS)

CAUTION:

Wear insulated gloves before performing the following operation.

- (a) Turn the power switch OFF.
- (b) Remove the service plug grip (see page [HB-154](#)).

NOTICE:

Turning the power switch ON (READY) with the service plug grip removed could cause malfunction. Therefore, never turn the power switch ON (READY) in this state.

- (c) Remove the inverter cover (see page [HV-531](#)).

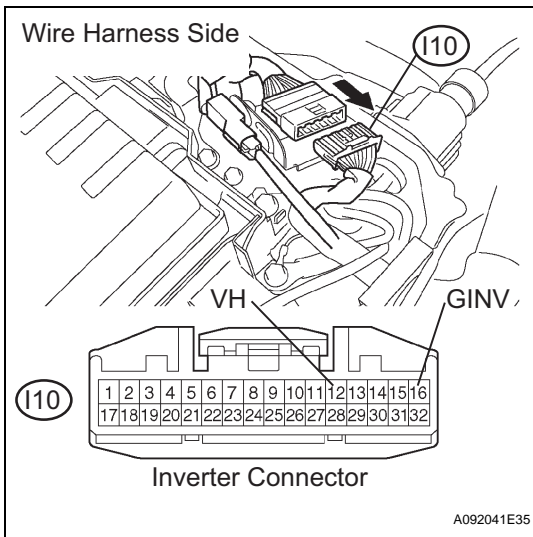

(d) Disconnect the I10 inverter connector.

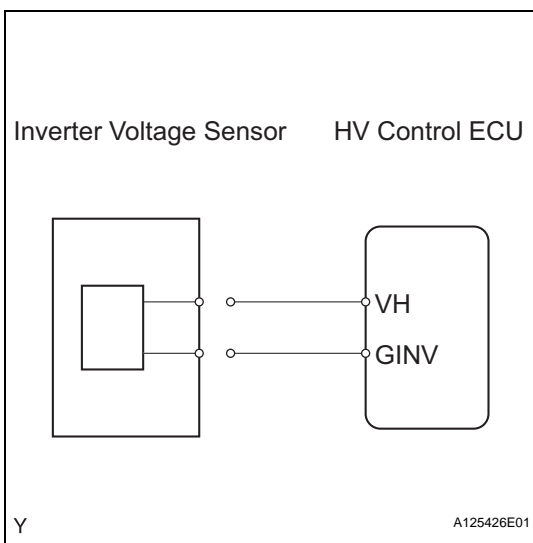

(e) Turn the power switch ON (IG).

HINT:

DTCs for the interlock switch system are output when turning the power switch ON (IG) with both service plug grip and inverter cover removed.

(f) Enter the following menus: DIAGNOSIS / OBD/MOBD / HV ECU / DATA LIST.

(g) Read the VH value.

Standard voltage:

0 V

(h) Turn the power switch OFF.

(i) Reconnect the inverter connector.

(j) Reinstall the inverter cover (see page HV-538).

(k) Reinstall the service plug grip (see page HB-154).

OK

REPLACE INVERTER WITH CONVERTER ASSEMBLY

NG

4 READ VALUE OF INTELLIGENT TESTER (CHECK FOR +B SHORT IN HYBRID VEHICLE CONTROL ECU)

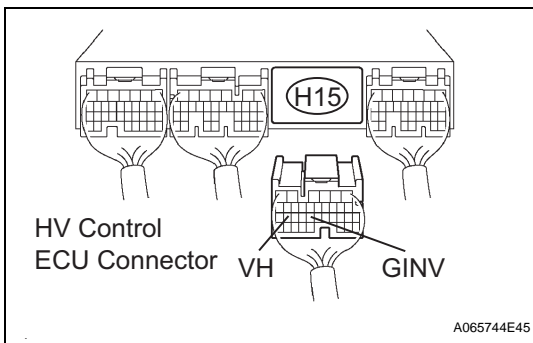

(a) Disconnect the H15 HV control ECU connector.

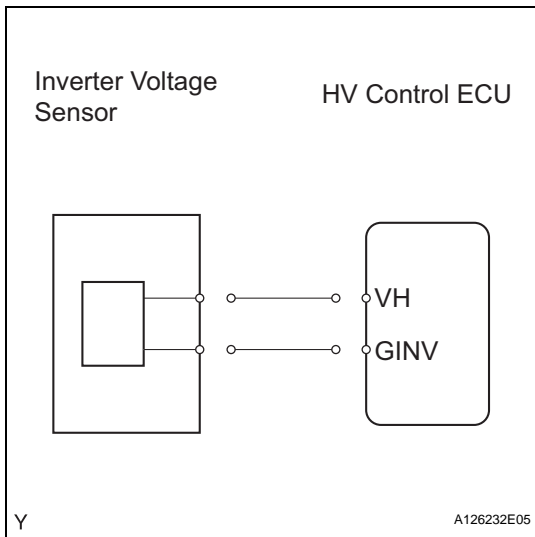

(b) Turn the power switch ON (IG).

HINT:

DTCs for the interlock switch system are output when turning the power switch ON (IG) with both service plug grip and inverter cover removed.

(c) Enter the following menus: DIAGNOSIS / OBD/MOBD / HV ECU / DATA LIST.

(d) Read the VH value.

Standard voltage:

0 V

(e) Reconnect the HV control ECU connector.

NG → **REPLACE HYBRID VEHICLE CONTROL ECU**

OK

REPAIR OR REPLACE HARNESS OR CONNECTOR

5 CHECK HARNESS AND CONNECTOR (HYBRID VEHICLE CONTROL ECU - INVERTER)

CAUTION:

Wear insulated gloves before performing the following operation.

(a) Turn the power switch OFF.

(b) Remove the service plug grip (see page [HB-154](#)).

NOTICE:

Turning the power switch ON (READY) with the service plug grip removed could cause malfunction. Therefore, never turn the power switch ON (READY) in this state.

(c) Remove the inverter cover (see page [HV-531](#)).

(d) Disconnect the H15 HV control ECU connector.

HV

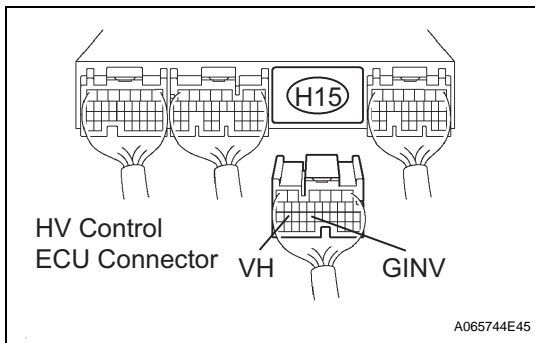

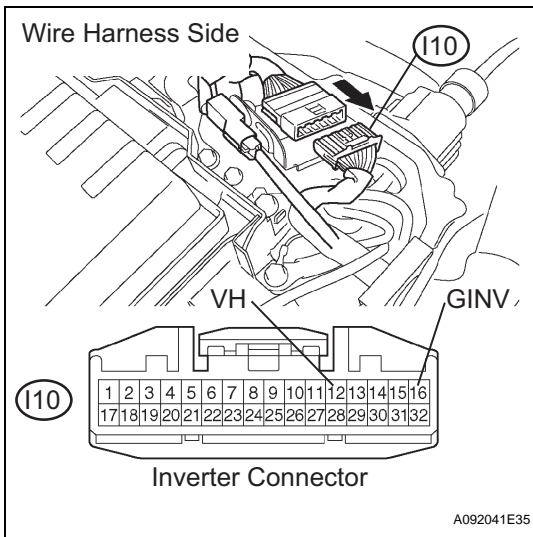

- (e) Disconnect the I10 inverter connector.
- (f) Measure the resistance between the wire harness side connectors.

Standard resistance (Check for open)

Tester Connection	Specified Condition
VH (H15-26) - VH (I10-12)	Below 1 Ω
GINV (H15-23) - GINV (I10-16)	Below 1 Ω

Standard resistance (Check for short)

Tester Connection	Specified Condition
VH (H15-26) or VH (I10-12) - Body ground	10 kΩ or higher
GINV (H15-23) or GINV (I10-16) - Body ground	10 kΩ or higher

- (g) Reconnect the inverter connector.
- (h) Reconnect the HV control ECU connector.
- (i) Reinstall the inverter cover (see page HV-538).
- (j) Reinstall the service plug grip (see page HB-154).

NG → **REPAIR OR REPLACE HARNESS OR CONNECTOR**

OK

6 INSPECT HYBRID VEHICLE CONTROL ECU (VH VOLTAGE)

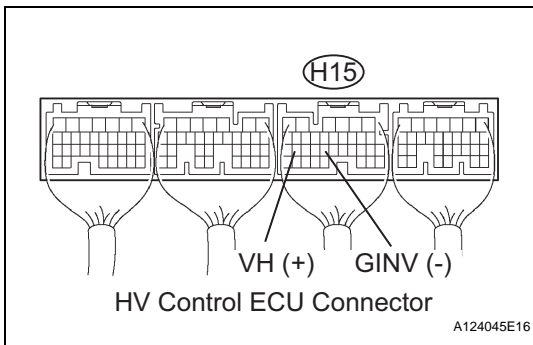

- (a) Turn the power switch ON (READY).
HINT:
DTCs for the interlock switch system are output when turning the power switch ON (IG) with both service plug grip and inverter cover removed.
- (b) Measure the voltage between the terminals of the H15 HV control ECU connector.

Standard voltage

Tester Connection	Specified Condition
VH (H15-26) - GINV (H15-23)	1.6 to 3.8 V

NG → **REPLACE INVERTER WITH CONVERTER ASSEMBLY**

OK

REPLACE HYBRID VEHICLE CONTROL ECU

HV

DTC	P0A78- 272	Drive Motor "A" Inverter Performance
------------	-----------------------	---

DESCRIPTION

See the description of the inverter (see page [HV-220](#)).

The inverter switches the power transistors ON and OFF in accordance with power transistor actuation signals received from the HV control ECU, in order to change the direction of the current that flows through the MG1/MG2. Also, the inverter regulates the duration of the switching time through PWM (Pulse Width Modulation) control, in order to control the voltage that is applied to the MG1/MG2.

DTC No.	INF Code	DTC Detection Condition	Trouble Area
P0A78	272	Abnormality in motor PWM circuit	<ul style="list-style-type: none"> • Wire harness or connector • Inverter with converter assembly

MONITOR DESCRIPTION

The HV control ECU monitors the motor PWM circuit. If there is an error in the power transistor actuation signals which are transmitted to the inverter, the HV control ECU interprets this as a malfunction of the motor PWM circuit.

The HV control ECU illuminates the MIL and sets a DTC.

MONITOR STRATEGY

Related DTCs	P0A78 (INF 272): Motor PWM malfunction
Required sensor / components	Motor inverter
Frequency of operation	Continuous
Duration	TOYOTA's intellectual property
MIL operation	1 driving cycle
Sequence of operation	None

HV

TYPICAL ENABLING CONDITIONS

The monitor will run whenever the following DTCs are not present	TOYOTA's intellectual property
Other conditions belong to TOYOTA's intellectual property	-

TYPICAL MALFUNCTION THRESHOLDS

Power transistor actuation signal	Abnormal
-----------------------------------	----------

COMPONENT OPERATING RANGE

Motor inverter	DTC P0A78 (INF 272) is not detected
----------------	-------------------------------------

WIRING DIAGRAM

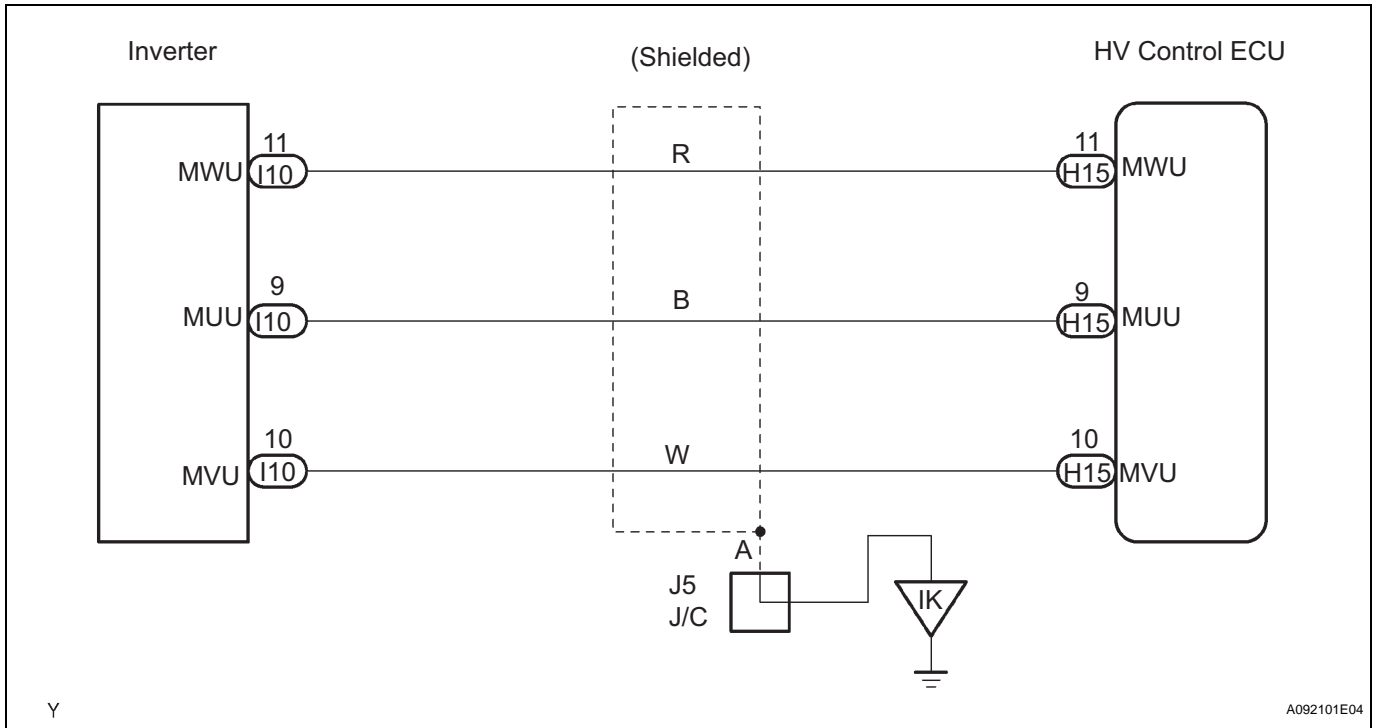

INSPECTION PROCEDURE

CAUTION:

- Before inspecting the high-voltage system, take safety precautions to prevent electrical shocks, such as wearing insulated gloves and removing the service plug grip. After removing the service plug grip, put it in your pocket to prevent other technicians from reconnecting it while you are servicing the high-voltage system.
- After disconnecting the service plug grip, wait for at least 5 minutes before touching any of the high-voltage connectors or terminals.

HINT:

At least 5 minutes are required to discharge the high-voltage condenser inside the inverter.

HV

1	READ OUTPUT DTC (HV ECU)
----------	---------------------------------

- (a) Connect the intelligent tester to the DLC3.
- (b) Turn the power switch ON (IG).
- (c) Turn the intelligent tester ON.
- (d) Enter the following menus: DIAGNOSIS / OBD/MOBD / HV ECU / DTC INFO / CURRENT CODES.
- (e) Read DTCs.

Result:

DTC P0A1D is output

YES	GO TO RELEVANT DTC CHART
------------	---------------------------------

NO

2 CHECK HARNESS AND CONNECTOR (HYBRID VEHICLE CONTROL ECU - INVERTER)

CAUTION:

Wear insulated gloves before performing the following operation.

- (a) Turn the power switch OFF.
- (b) Remove the service plug grip (see page [HB-154](#)).

NOTICE:

Turning the power switch ON (READY) with the service plug grip removed could cause malfunction. Therefore, never turn the power switch ON (READY) in this state.

- (c) Disconnect the H15 HV control ECU connector.
- (d) Remove the inverter cover (see page [HV-531](#)).

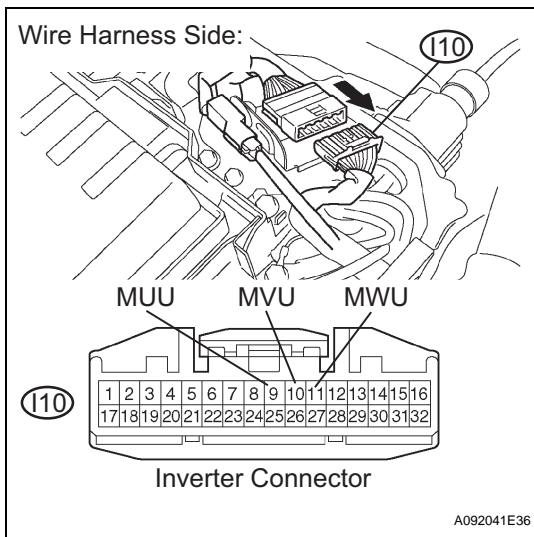
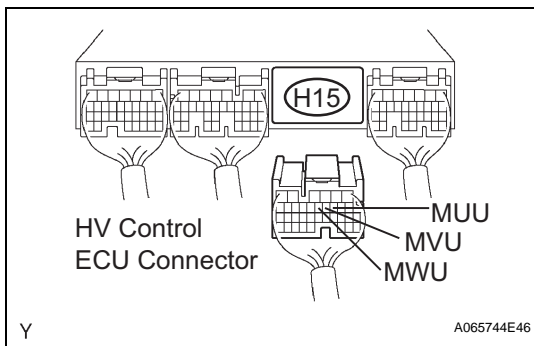

- (e) Disconnect the I10 inverter connector.
- (f) Measure the resistance between the wire harness side connectors.

Standard resistance (Check for open)

Tester Connection	Specified Condition
MUU (H15-9) - MUU (I10-9)	Below 1 Ω
MVU (H15-10) - MVU (I10-10)	Below 1 Ω
MWU (H15-11) - MWU (I10-11)	Below 1 Ω

Standard resistance (Check for short)

Tester Connection	Specified Condition
MUU (H15-9) or MUU (I10-9) - Body ground	10 kΩ or higher
MVU (H15-10) or MVU (I10-10) - Body ground	10 kΩ or higher
MWU (H15-11) or MWU (I10-11) - Body ground	10 kΩ or higher

- (g) Reconnect the inverter connector.
- (h) Reconnect the HV control ECU connector.
- (i) Reinstall the inverter cover (see page [HV-538](#)).
- (j) Reinstall the service plug grip (see page [HB-154](#)).

NG **REPAIR OR REPLACE HARNESS OR CONNECTOR**

OK

REPLACE INVERTER WITH CONVERTER ASSEMBLY

DTC	P0A78-278	Drive Motor "A" Inverter Performance
DTC	P0A78-280	Drive Motor "A" Inverter Performance

DESCRIPTION

See the description of the inverter (see page [HV-220](#)).

If the motor inverter detects a circuit malfunction or over-voltage, the inverter transmits this information to the OVH terminal of the HV control ECU via the motor inverter over-voltage signal line.

The HV control ECU monitors the motor inverter over-voltage signal line to detect the malfunction.

DTC No.	INF Code	DTC Detection Condition	Trouble Area
P0A78	278	+B short in motor inverter over-voltage (OVH) signal circuit	<ul style="list-style-type: none"> Wire harness or connector Inverter with converter assembly
P0A78	280	Open or GND short in motor inverter over-voltage (OVH) signal circuit	<ul style="list-style-type: none"> Wire harness or connector Inverter with converter assembly

MONITOR DESCRIPTION

The HV control ECU monitors the motor inverter over-voltage (OVH) signal line. If the HV control ECU detects an open or short malfunction of the OVH signal circuit, the HV control ECU illuminates the MIL and sets a DTC.

MONITOR STRATEGY

Related DTCs	P0A78 (INF 278 / 280): Motor inverter / Motor inverter Sinv detection
Required sensor / components	Motor inverter
Frequency of operation	Continuous
Duration	TOYOTA's intellectual property
MIL operation	1 driving cycle
Sequence of operation	None

HV

TYPICAL ENABLING CONDITIONS

The monitor will run whenever the following DTCs are not present	TOYOTA's intellectual property
Other conditions belong to TOYOTA's intellectual property	-

TYPICAL MALFUNCTION THRESHOLDS

Over-voltage signal circuit	Open or short
-----------------------------	---------------

COMPONENT OPERATING RANGE

Motor inverter	DTC P0A78 (INF 278 / 280) is not detected
----------------	---

WIRING DIAGRAM

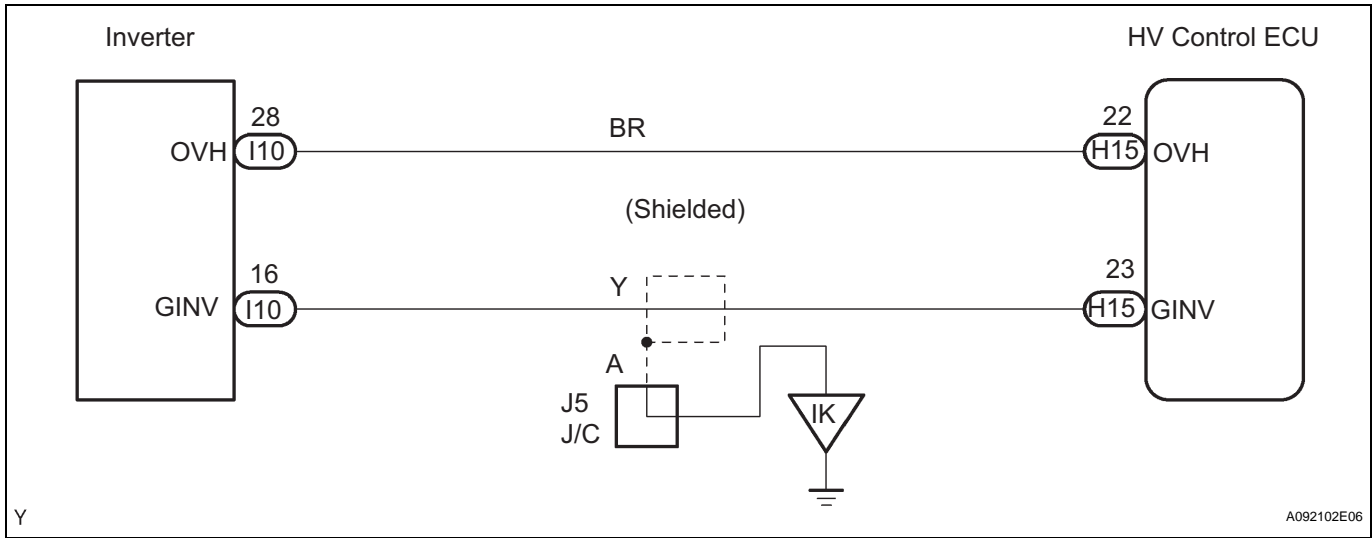

INSPECTION PROCEDURE

CAUTION:

- Before inspecting the high-voltage system, take safety precautions to prevent electrical shocks, such as wearing insulated gloves and removing the service plug grip. After removing the service plug grip, put it in your pocket to prevent other technicians from reconnecting it while you are servicing the high-voltage system.
- After disconnecting the service plug grip, wait for at least 5 minutes before touching any of the high-voltage connectors or terminals.

HINT:

At least 5 minutes are required to discharge the high-voltage condenser inside the inverter.

HV

1 CHECK HARNESS AND CONNECTOR (HYBRID CONTROL ECU - INVERTER)

CAUTION:

Wear insulated gloves before performing the following operation.

- (a) Turn the power switch OFF.
- (b) Remove the service plug grip (see page [HB-154](#)).

NOTICE:

Turning the power switch ON (READY) with the service plug grip removed could cause malfunction. Therefore, never turn the power switch ON (READY) in this state.

- (c) Disconnect the H15 HV control ECU connector.
- (d) Remove the inverter cover (see page [HV-531](#)).

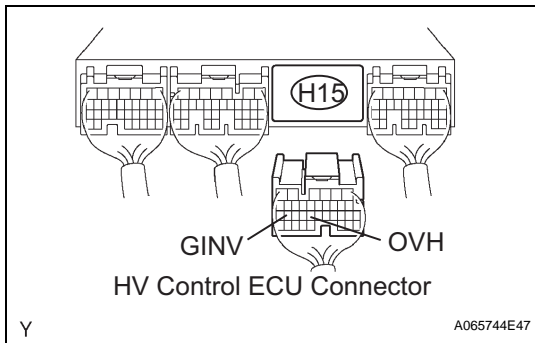

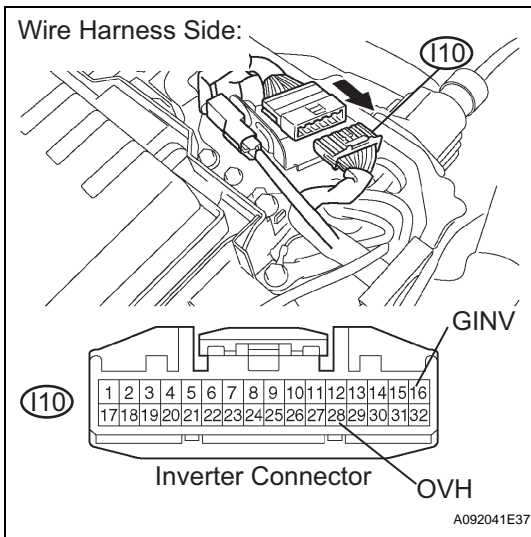

- (e) Disconnect the I10 inverter connector.
- (f) Turn the power switch ON (IG).
HINT:
DTCs for the interlock switch system are output when turning the power switch ON (IG) with both service plug grip and inverter cover removed.
- (g) Measure the voltage between the terminals of the HV control ECU connector and body ground.

Standard voltage

Tester Connection	Specified Condition
OVH (H15-22) - Body ground	Below 1 V
GINV (H15-23) - Body ground	Below 1 V

- (h) Turn the power switch OFF.
- (i) Measure the resistance between the wire harness side connectors.

Standard resistance (Check for open)

Tester Connection	Specified Condition
OVH (H15-22) - OVH (I10-28)	Below 1 Ω
GINV (H15-23) - GINV (I10-16)	Below 1 Ω

Standard resistance (Check for short)

Tester Connection	Specified Condition
OVH (H15-22) or OVH (I10-28) - Body ground	10 kΩ or higher
GINV (H15-23) or GINV (I10-16) - Body ground	10 kΩ or higher

- (j) Reconnect the inverter connector.
- (k) Reconnect the HV control ECU connector.
- (l) Reinstall the inverter cover (see page HV-538).
- (m) Reinstall the service plug grip (see page HB-154).

HV

NG REPAIR OR REPLACE HARNESS OR CONNECTOR

OK

REPLACE INVERTER WITH CONVERTER ASSEMBLY

DTC	P0A78-279	Drive Motor "A" Inverter Performance
DTC	P0A78-503	Drive Motor "A" Inverter Performance
DTC	P0A78-504	Drive Motor "A" Inverter Performance

DESCRIPTION

See the description of the inverter (see page [HV-220](#)).

If the motor inverter detects a circuit malfunction or over-voltage, the inverter transmits this information to the OVH terminal of the HV control ECU via the motor inverter over-voltage signal line.

DTC No.	INF Code	DTC Detection Condition	Trouble Area
P0A78	279	Motor inverter over-voltage (OVH) signal detection (over-voltage by inverter assembly malfunction)	<ul style="list-style-type: none"> • Wire harness or connector • HV transaxle assembly • Hybrid vehicle motor • Hybrid vehicle generator • HV control ECU • Inverter with converter assembly
P0A78	503	Motor inverter over-voltage (OVH) signal detection (over-voltage by HV control ECU malfunction)	<ul style="list-style-type: none"> • Wire harness or connector • HV transaxle assembly • Hybrid vehicle motor • Hybrid vehicle generator • HV control ECU • Inverter with converter assembly
P0A78	504	Motor inverter over-voltage (OVH) signal detection (over-voltage by HV transaxle assembly malfunction)	<ul style="list-style-type: none"> • Wire harness or connector • HV transaxle assembly • Hybrid vehicle motor • Hybrid vehicle generator • HV control ECU • Inverter with converter assembly

HV

MONITOR DESCRIPTION

If the motor inverter detects over-voltage, it transmits an over-voltage signal to the HV control ECU. Upon receiving this signal, the HV control ECU illuminates the MIL and sets a DTC.

MONITOR STRATEGY

Related DTCs	P0A78 (INF 279 / 503 / 504): Motor inverter / OVH detection over voltage
Required sensor / components	Motor inverter
Frequency of operation	Continuous
Duration	TOYOTA's intellectual property
MIL operation	Immediately
Sequence of operation	None

TYPICAL ENABLING CONDITIONS

The monitor will run whenever the following DTCs are not present	TOYOTA's intellectual property
No other condition	-

TYPICAL MALFUNCTION THRESHOLDS

Motor inverter	Over-voltage
----------------	--------------

COMPONENT OPERATING RANGE

Motor inverter	DTC P0A78 (INF 279 / 503 / 504) is not detected
----------------	---

WIRING DIAGRAM

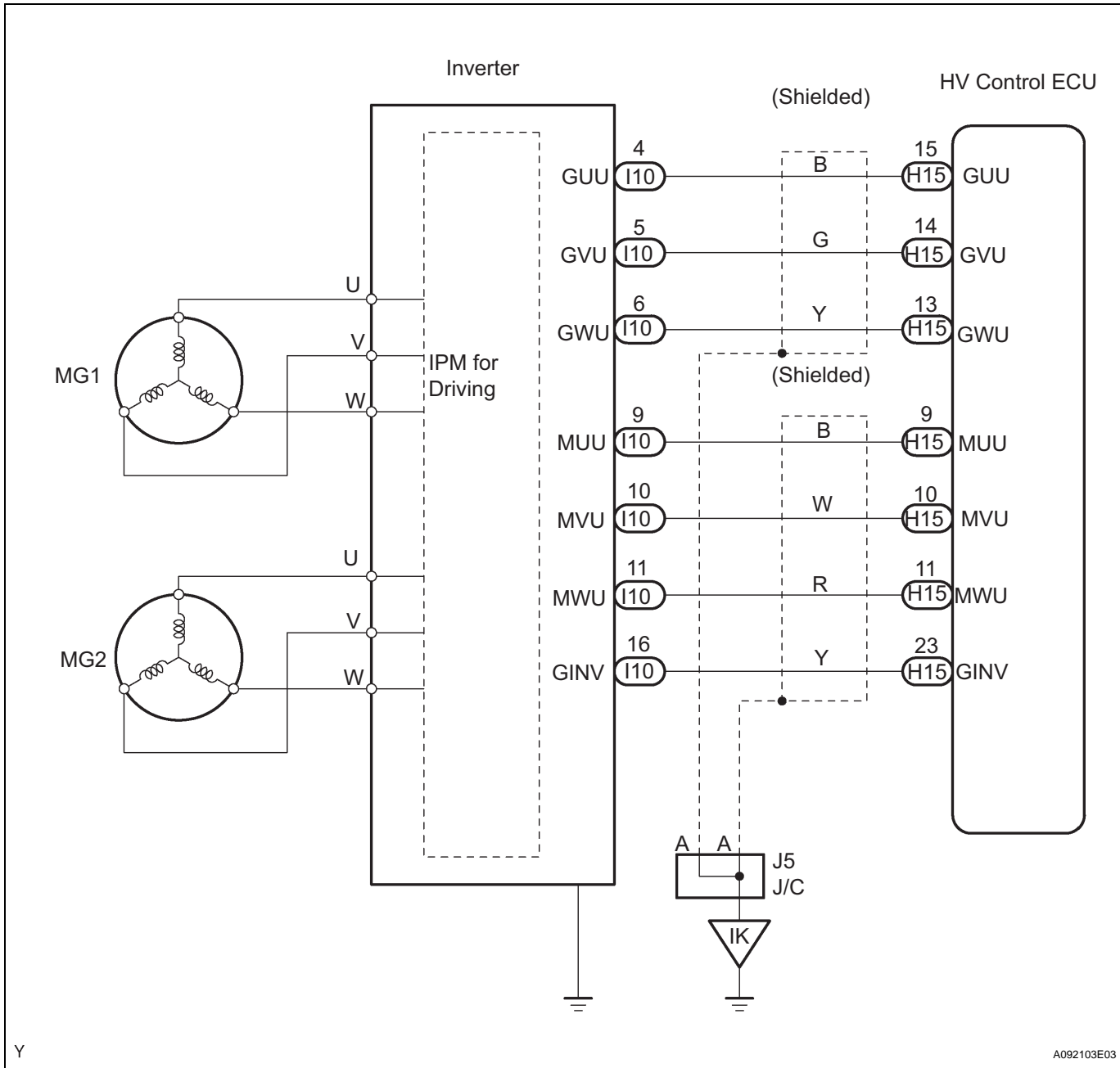

HV

INSPECTION PROCEDURE

CAUTION:

- Before inspecting the high-voltage system, take safety precautions to prevent electrical shocks, such as wearing insulated gloves and removing the service plug grip. After removing the service plug grip, put it in your pocket to prevent other technicians from reconnecting it while you are servicing the high-voltage system.
- After disconnecting the service plug grip, wait for at least 5 minutes before touching any of the high-voltage connectors or terminals.

HINT:

At least 5 minutes are required to discharge the high-voltage condenser inside the inverter.

1 CONFIRM INFORMATION (EXCLUSIVE INFO 3)

- Connect the intelligent tester to the DLC3.
- Turn the power switch ON (IG).
- Turn the intelligent tester ON.
- Enter the following menus: DIAGNOSIS / OBD/MOBD / HV ECU / DTC INFO / CURRENT CODES.
- Select DTC P0A78 to display its freeze frame data.
- Select the item that has INF code 279, 503, or 504 from among INFORMATION 1 to 5, and press ENTER.
- Read EXCLUSIVE INFO 3.

Result:

-32 to 32 (during driving without battery power)

HINT:

If the value is inside the range shown above, DTCs other than P0A78 (INF 279, 503 and 504) have been detected as well. Perform troubleshooting for those DTCs first.

YES

GO TO RELEVANT DTC CHART

NO

2 CHECK CONNECTION CONDITION OF HYBRID VEHICLE CONTROL ECU CONNECTOR (LOOSENESS AND POOR CONTACT)

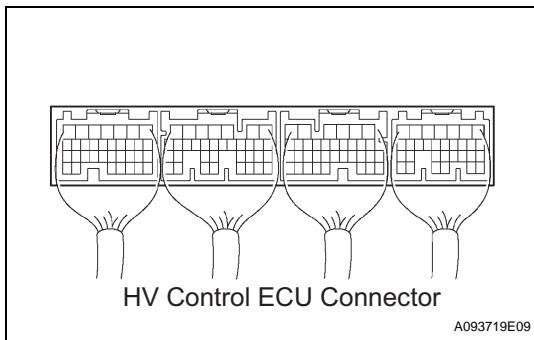

- Check the connection condition of all the connectors at the HV control ECU.

OK:

Connectors have been connected securely and there is no poor connection.

NG

CONNECT SECURELY

OK

HV

3 CHECK CONNECTION CONDITION OF INVERTER CONNECTOR (LOOSENESS AND POOR CONTACT)

CAUTION:

Wear insulated gloves before performing the following operation.

- (a) Turn the power switch OFF.
- (b) Remove the service plug grip (see page [HB-154](#)).

NOTICE:

Turning the power switch ON (READY) with the service plug grip removed could cause malfunction. Therefore, never turn the power switch ON (READY) in this state.

- (c) Remove the inverter cover (see page [HV-531](#)).
- (d) Check the connection condition of the I9 and I10 inverter connectors.

OK:

Connectors have been connected securely and there is no poor connection.

- (e) Reinstall the inverter cover (see page [HV-538](#)).
- (f) Reinstall the service plug grip (see page [HB-154](#)).

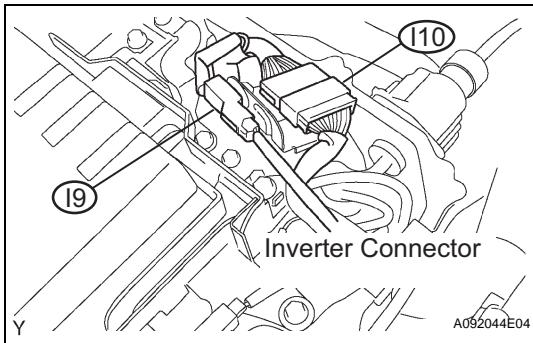

NG **CONNECT SECURELY**

OK

4 CONFIRM INFORMATION (EXCLUSIVE INFO 4)

- (a) Connect the intelligent tester to the DLC3.
- (b) Turn the power switch ON (IG).

HINT:

DTCs for the interlock switch system are output when turning the power switch ON (IG) with both the service plug grip and inverter cover removed.

- (c) Turn the intelligent tester ON.
- (d) Enter the following menus: DIAGNOSIS / OBD/MOBD / HV ECU / DTC INFO / CURRENT CODES.
- (e) Select DTC P0A78 to display its freeze frame data.
- (f) Select the item that has INF code 279, 503, or 504 from among INFORMATION 1 to 5, and press ENTER.
- (g) Read EXCLUSIVE INFO 4.

HV

Result

Displayed in Exclusive Information 4	Proceed to
-127 to -120, -95 to -88, -63 to -56, -31 to -24, 1 to 8, 33 to 40, 65 to 72, 97 to 104	A
-119 to -112, -87 to -80, -55 to -48, -23 to -16, 9 to 16, 41 to 48, 73 to 80, 105 to 112	B
-111 to -104, -79 to -72, -47 to -40, -15 to -8, 17 to 24, 49 to 56, 81 to 88, 113 to 120	C
-103 to -96, -71 to -64, -39 to -32, -7 to 0, 25 to 32, 57 to 64, 89 to 96, 121 to 127	D

- B** → REPLACE HYBRID VEHICLE CONTROL ECU
- C** → REPLACE INVERTER WITH CONVERTER ASSEMBLY
- D** → REPLACE HYBRID VEHICLE TRANSAXLE ASSEMBLY

A

5 READ OUTPUT DTC (HV ECU)

- (a) Connect the intelligent tester to the DLC3.
- (b) Turn the power switch ON (IG).
- HINT:
DTCs for the interlock switch system are output when turning the power switch ON (IG) with both the service plug grip and inverter cover removed.
- (c) Turn the intelligent tester ON.
- (d) Enter the following menus: DIAGNOSIS / OBD/MOBD / HV ECU / DTC INFO / CURRENT CODES.
- (e) Read DTCs.

Result: DTCs listed in the table below are output

DTC No.	INF Code	Detection Item	See Page
P0A78	266	Drive Motor "A" Inverter Performance	HV-220
P0A94	558 or 560	DC / DC Converter Performance	HV-389
P0A94	588	DC / DC Converter Performance	HV-409
P0A94	589	DC / DC Converter Performance	HV-412
P0ADB	227	Hybrid Battery Positive Contactor Control Circuit Low	HV-439
P0ADF	229	Hybrid Battery Negative Contactor Control Circuit Low	HV-441
P3000	125	HV Battery Malfunction	HV-466
P3004	131	Power Cable Malfunction	HV-470

YES → GO TO THE PAGE NUMBER SHOWN IN THE TABLE ABOVE

NO

6 INSPECT HYBRID VEHICLE MOTOR ASSEMBLY

CAUTION:
Wear insulated gloves before performing the following operation.

- (a) Turn the power switch OFF.
- (b) Remove the service plug grip (see page [HB-154](#)).

NOTICE:
Turning the power switch ON (READY) with the service plug grip removed could cause malfunction. Therefore, never turn the power switch ON (READY) in this state.

- (c) Remove the inverter cover (see page [HV-531](#)).

HV

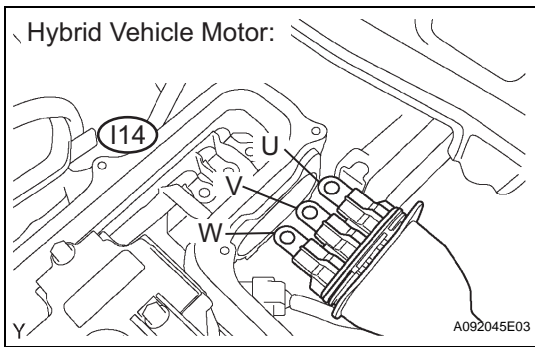

- (d) Disconnect the three-phase alternating current cable for the hybrid vehicle motor from the inverter.
- (e) Using a milliohm meter, measure the resistance between the three-phase alternating current cable terminals of the hybrid vehicle motor.

NOTICE:

If the motor temperature is too high, the resistance varies considerably, which hinders determining malfunction. Therefore, measure the resistance at a minimum 8 hours after the vehicle has been stopped.

Standard resistance

Tester Connection	Specified Condition*
U (I14-1) - V (I14-2)	Below 135 mΩ at 20°C
V (I14-2) - W (I14-3)	Below 135 mΩ at 20°C
W (I14-3) - U (I14-1)	Below 135 mΩ at 20°C

*: Apply the formula given below to correct the resistance.

$$R_{20} = R_t / \{1 + 0.00393 \times (T - 20)\}$$

R₂₀: Resistance converted to 20°C (mΩ)

R_t: Resistance between measured lines (mΩ)

T: Ambient air temperature during measurement (°C)

- (f) Calculate the difference between the maximum and minimum resistance between terminals U - V, V - W, and W - U.

Standard resistance:

Below 2 mΩ

- (g) Using a megohmmeter, measure the insulation resistance between the three-phase alternating current cable terminals of the hybrid vehicle motor and the body ground.

Standard resistance

Tester Connection	Specified Condition
U (I14-1) - Body ground	10 MΩ or higher
V (I14-2) - Body ground	10 MΩ or higher
W (I14-3) - Body ground	10 MΩ or higher

- (h) Reconnect the three-phase alternating current cable for the hybrid vehicle motor.

NG

REPLACE HYBRID VEHICLE MOTOR ASSEMBLY

OK

7 INSPECT HYBRID VEHICLE GENERATOR ASSEMBLY

CAUTION:

Wear insulated gloves before performing the following operation.

- (a) Check that the service plug grip and inverter cover have been removed.

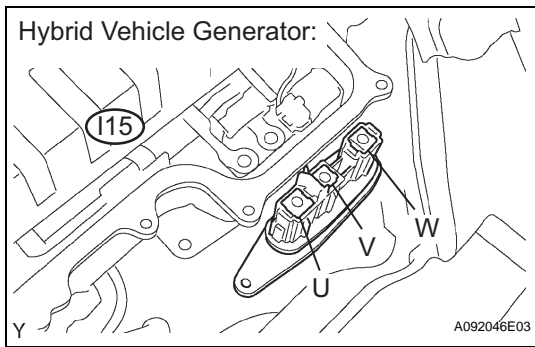

- (b) Disconnect the three-phase alternating current cable for the hybrid vehicle generator from the inverter.
- (c) Using a milliohm meter, measure the resistance between the three-phase alternating current cable terminals of the hybrid vehicle generator.

NOTICE:

If the generator temperature is too high, the resistance varies considerably, which hinders determining malfunction. Therefore, measure the resistance at a minimum 8 hours after the vehicle has been stopped.
Standard resistance

Tester Connection	Specified Condition*
U (I15-1) - V (I15-2)	Below 109 mΩ at 20°C
V (I15-2) - W (I15-3)	Below 109 mΩ at 20°C
W (I15-3) - U (I15-1)	Below 109 mΩ at 20°C

*: Apply the formula given below to correct the resistance.

$$R_{20} = R_t / \{1 + 0.00393 \times (T - 20)\}$$

R₂₀: Resistance converted to 20°C (mΩ)

R_t: Resistance between measured lines (mΩ)

T: Ambient air temperature during measurement (°C)

- (d) Calculate the difference between the maximum and minimum resistance between terminals U - V, V - W, and W - U.

Standard resistance:

Below 2 mΩ

- (e) Using a megohmmeter, measure the insulation resistance between the three-phase alternating current cable terminals of the hybrid vehicle generator and the body ground.

Standard resistance

Tester Connection	Specified Condition
U (I15-1) - Body ground	10 MΩ or higher
V (I15-2) - Body ground	10 MΩ or higher
W (I15-3) - Body ground	10 MΩ or higher

- (f) Reconnect the three-phase alternating current cable for the hybrid vehicle generator.

NG → **REPLACE HYBRID VEHICLE GENERATOR ASSEMBLY**

OK

8 PERFORM ACTIVE TEST BY INTELLIGENT TESTER (INVERTER STOP)

CAUTION:

Wear insulated gloves before performing the following operation.

- (a) Check that the service plug grip and inverter cover have been removed.
- (b) Connect the intelligent tester to the DLC3.
- (c) Turn the power switch ON (IG).

HINT:

DTCs for the interlock switch system are output when turning the power switch ON (IG) with both service plug grip and inverter cover removed.

- (d) Turn the intelligent tester ON.
- (e) Enter the following menus: DIAGNOSIS / OBD/MOBD / HV ECU / ACTIVE TEST.
- (f) Measure the voltage between the terminals of the inverter connector while effecting INVERTER STOP.

Standard voltage

Tester Connection	Specified Condition
MUU (I10-9) - GINV (I10-16)	12 to 16 V
MVU (I10-10) - GINV (I10-16)	12 to 16 V
MWU (I10-11) - GINV (I10-16)	12 to 16 V
GUU (I10-4) - GINV (I10-16)	12 to 16 V
GVU (I10-5) - GINV (I10-16)	12 to 16 V
GWU (I10-6) - GINV (I10-16)	12 to 16 V

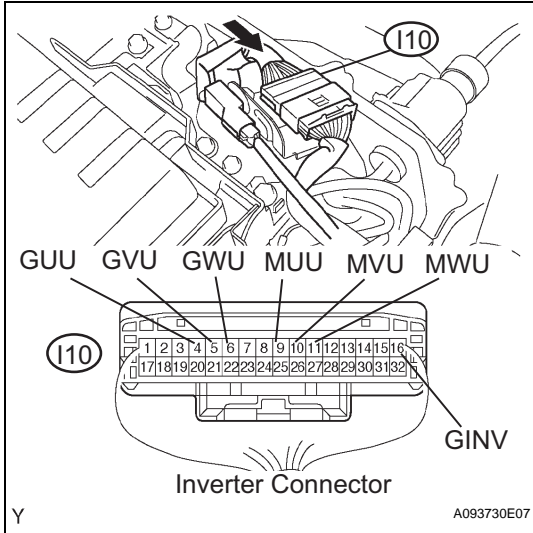

- (g) Turn the power switch OFF.

OK

REPLACE HYBRID VEHICLE CONTROL ECU AND INVERTER WITH CONVERTER ASSEMBLY

NG

9 PERFORM ACTIVE TEST BY INTELLIGENT TESTER (INVERTER STOP)

CAUTION:

Wear insulated gloves before performing the following operation.

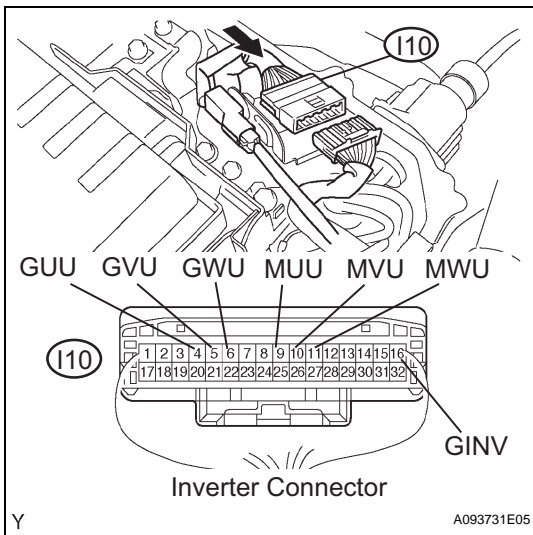

- (a) Check that the service plug grip and inverter cover have been removed.
- (b) Disconnect the I10 inverter connector.
- (c) Connect the intelligent tester to the DLC3.
- (d) Turn the power switch ON (IG).

HINT:

DTCs for the interlock switch system are output when turning the power switch ON (IG) with both service plug grip and inverter cover removed.

- (e) Turn the intelligent tester ON.
- (f) Enter the following menus: DIAGNOSIS / OBD/MOBD / HV ECU / ACTIVE TEST.
- (g) Measure the voltage between the terminals of the inverter connector while effecting INVERTER STOP.

Standard voltage

Tester Connection	Specified Condition
MUU (I10-9) - GINV (I10-16)	14 to 16 V
MVU (I10-10) - GINV (I10-16)	14 to 16 V
MWU (I10-11) - GINV (I10-16)	14 to 16 V
GUU (I10-4) - GINV (I10-16)	14 to 16 V
GVU (I10-5) - GINV (I10-16)	14 to 16 V
GWU (I10-6) - GINV (I10-16)	14 to 16 V

HV

- (h) Turn the power switch OFF.
- (i) Reconnect the inverter connector.
- (j) Reinstall the inverter cover (see page [HV-538](#)).
- (k) Reinstall the service plug grip (see page [HB-154](#)).

NG**REPLACE INVERTER WITH CONVERTER ASSEMBLY****OK****REPLACE HYBRID VEHICLE CONTROL ECU**

DTC	P0A78- 282	Drive Motor "A" Inverter Performance
------------	-----------------------	---

DESCRIPTION

See the description of the inverter (see page [HV-220](#)).

If the motor inverter detects a circuit malfunction or over-voltage, the inverter transmits this information to the OVH terminal of the HV control ECU via the motor inverter over-voltage signal line.

DTC No.	INF Code	DTC Detection Condition	Trouble Area
P0A78	282	Motor inverter over voltage (OVH) signal detection (circuit malfunction)	<ul style="list-style-type: none"> • Wire harness or connector • Inverter with converter assembly

MONITOR DESCRIPTION

If the motor inverter detects a circuit malfunction, it transmits a motor inverter over-voltage signal to the HV control ECU. Upon receiving this signal, the HV control ECU illuminates the MIL and sets a DTC.

MONITOR STRATEGY

Related DTCs	P0A78 (INF 282): Motor inverter / OVH detection circuit malfunction
Required sensor / components	Motor inverter
Frequency of operation	Continuous
Duration	TOYOTA's intellectual property
MIL operation	Immediately
Sequence of operation	None

TYPICAL ENABLING CONDITIONS

The monitor will run whenever the following DTCs are not present	TOYOTA's intellectual property
No other condition	-

HV

TYPICAL MALFUNCTION THRESHOLDS

Motor inverter	Circuit malfunction
----------------	---------------------

COMPONENT OPERATING RANGE

Motor inverter	DTC P0A78 (INF 282) is not detected
----------------	-------------------------------------

WIRING DIAGRAM

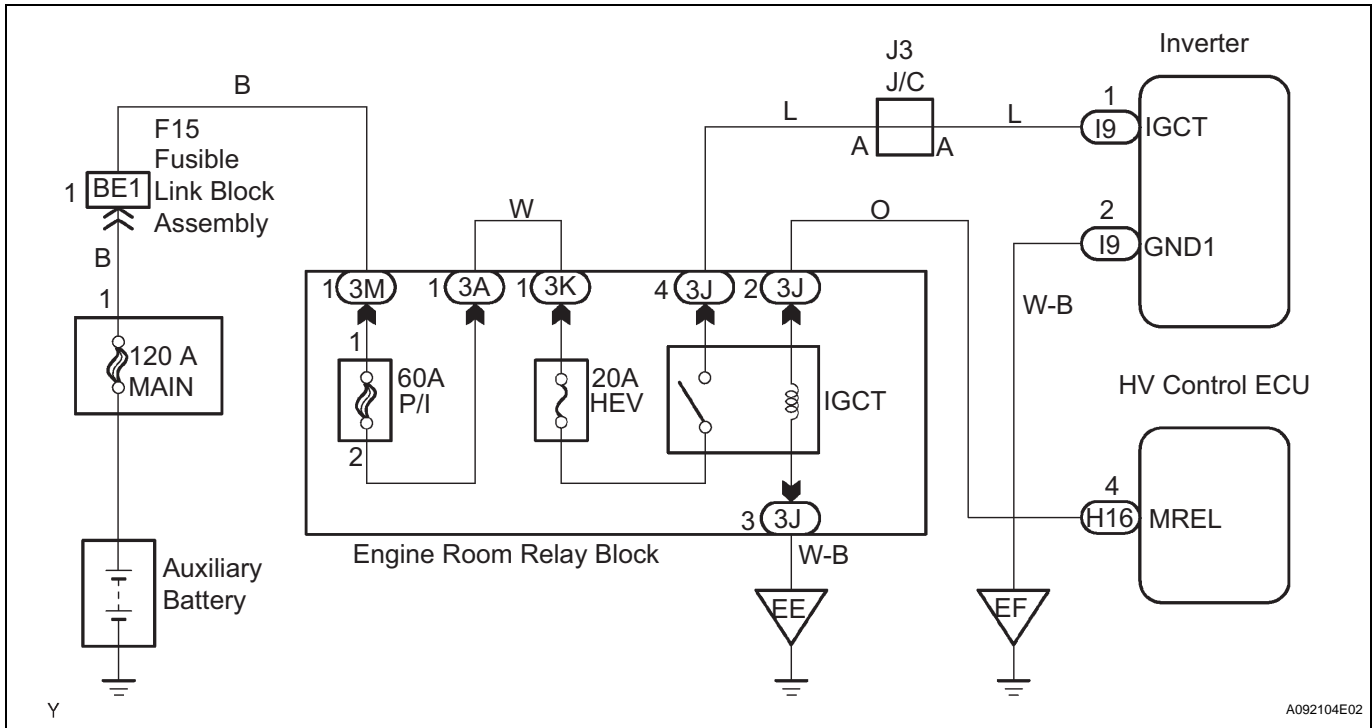

INSPECTION PROCEDURE

CAUTION:

- Before inspecting the high-voltage system, take safety precautions to prevent electrical shocks, such as wearing insulated gloves and removing the service plug grip. After removing the service plug grip, put it in your pocket to prevent other technicians from reconnecting it while you are servicing the high-voltage system.
- After disconnecting the service plug grip, wait for at least 5 minutes before touching any of the high-voltage connectors or terminals.

HINT:

At least 5 minutes are required to discharge the high-voltage condenser inside the inverter.

1 READ OUTPUT DTC (HV ECU)

- Connect the intelligent tester to the DLC3.
- Turn the power switch ON (IG).
- Turn the intelligent tester ON.
- Enter the following menus: DIAGNOSIS / OBD/MOBD / HV ECU / DTC INFO / CURRENT CODES.
- Read DTCs.

Result: DTC listed in table below is output

DTC No.	INF Code	Detection Item	See Page
P0A78	278 or 280	Drive Motor "A" Inverter performance	HV-231

YES → **GO TO THE PAGE NUMBER SHOWN IN THE TABLE ABOVE**

NO

2	CHECK CONNECTION CONDITION OF INVERTER CONNECTOR (LOOSENESS AND POOR CONTACT)
----------	--

CAUTION:

Wear insulated gloves before performing the following operation.

- (a) Turn the power switch OFF.
- (b) Remove the service plug grip (see page [HB-154](#)).

NOTICE:

Turning the power switch ON (READY) with the service plug grip removed could cause malfunction. Therefore, never turn the power switch ON (READY) in this state.

- (c) Remove the inverter cover (see page [HV-531](#)).
- (d) Check the connection condition of the I9 and I10 inverter connectors.

OK:

Connectors have been connected securely and there is no poor connection.

- (e) Reinstall the inverter cover (see page [HV-538](#)).
- (f) Reinstall the service plug grip (see page [HB-154](#)).

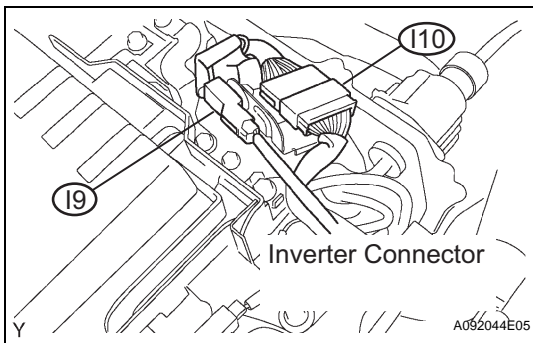

NG

CONNECT SECURELY

OK

3	READ OUTPUT DTC (HV ECU)
----------	---------------------------------

- (a) Connect the intelligent tester to the DLC3.
- (b) Turn the power switch ON (IG).

HINT:

DTCs for the interlock switch system are output when turning the power switch ON (IG) with both service plug grip and inverter cover removed.

- (c) Turn the intelligent tester ON.
- (d) Enter the following menus: DIAGNOSIS / OBD/MOBD / HV ECU / DTC INFO / CURRENT CODES.
- (e) Read DTCs.

Result:

DTCs P0A78 (INF 282, 286) and P0A7A (INF 324) (inverter circuit malfunction) are output

NO

REPLACE INVERTER WITH CONVERTER ASSEMBLY

YES

4	INSPECT INVERTER WITH CONVERTER ASSEMBLY (IGCT VOLTAGE)
----------	--

CAUTION:

Wear insulated gloves before performing the following operation.

HV

- (a) Turn the power switch OFF.
- (b) Remove the service plug grip (see page [HB-154](#)).

NOTICE:

Turning the power switch ON (READY) with the service plug grip removed could cause malfunction. Therefore, never turn the power switch ON (READY) in this state.

- (c) Remove the inverter cover (see page [HV-531](#)).
- (d) Turn the power switch ON (IG).

HINT:

DTCs for the interlock switch system are output when turning the power switch ON (IG) with both service plug grip and inverter cover removed.

- (e) Measure the voltage between the terminals of the inverter connector.

Standard voltage

Tester Connection	Specified Condition
IGCT (I9-1) - GND1 (I9-2)	8 V or more

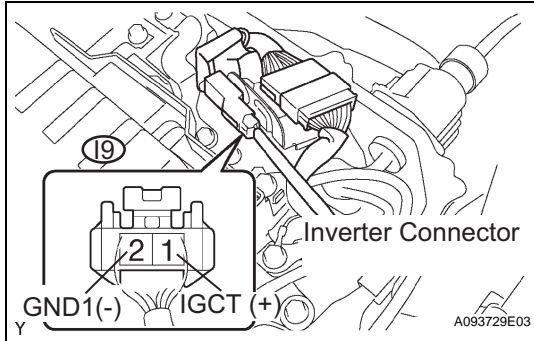

- (f) Turn the power switch OFF.
- (g) Reinstall the inverter cover (see page [HV-538](#)).
- (h) Reinstall the service plug grip (see page [HB-154](#)).

NG → **REPAIR OR REPLACE HARNESS OR CONNECTOR**

OK

REPLACE INVERTER WITH CONVERTER ASSEMBLY

DTC	P0A78-283	Drive Motor "A" Inverter Performance
DTC	P0A78-285	Drive Motor "A" Inverter Performance

DESCRIPTION

See the description of the inverter (see page [HV-220](#)).

If the motor inverter has a circuit malfunction, internal short, or overheats, the inverter transmits this information to the MFIV terminal of the HV control ECU via the motor inverter fail signal line.

The HV control ECU monitors the motor inverter fail signal line and detects a malfunction.

DTC No.	INF Code	DTC Detection Condition	Trouble Area
P0A78	283	+B short in motor inverter fail (MFIV) signal circuit	<ul style="list-style-type: none"> Wire harness or connector Inverter with converter assembly
P0A78	285	Open or GND short in motor inverter fail (MFIV) signal circuit	<ul style="list-style-type: none"> Wire harness or connector Inverter with converter assembly

MONITOR DESCRIPTION

The HV control ECU monitors the motor inverter fail (MFIV) signal line. If the HV control ECU detects an open or short malfunction of the MFIV signal circuit, the HV control ECU illuminates the MIL and sets a DTC.

MONITOR STRATEGY

Related DTCs	P0A78 (INF 283 / 285): Motor inverter/Motor inverter Finv detection
Required sensor / components	Motor inverter
Frequency of operation	Continuous
Duration	TOYOTA's intellectual property
MIL operation	1 driving cycle
Sequence of operation	None

HV

TYPICAL ENABLING CONDITIONS

The monitor will run whenever the following DTCs are not present	TOYOTA's intellectual property
Other conditions belong to TOYOTA's intellectual property	-

TYPICAL MALFUNCTION THRESHOLDS

Motor inverter fail signal circuit	Open or short
------------------------------------	---------------

COMPONENT OPERATING RANGE

Motor inverter	DTC P0A78 (INF 283 / 285) is not detected
----------------	---

WIRING DIAGRAM

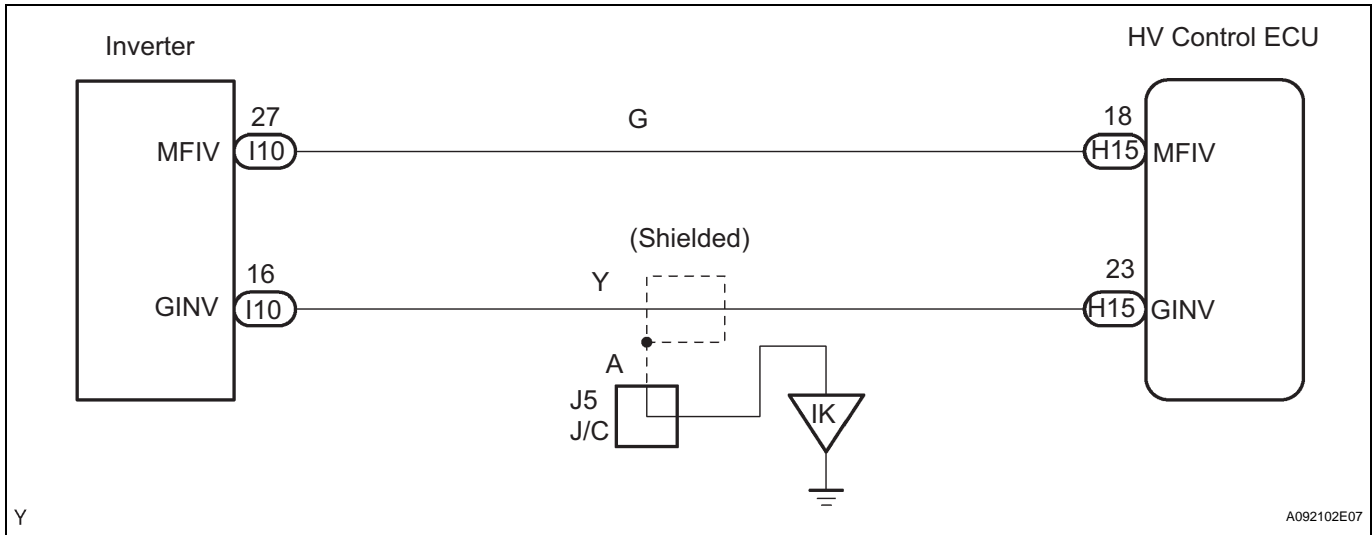

INSPECTION PROCEDURE

CAUTION:

- Before inspecting the high-voltage system, take safety precautions to prevent electrical shocks, such as wearing insulated gloves and removing the service plug grip. After removing the service plug grip, put it in your pocket to prevent other technicians from reconnecting it while you are servicing the high-voltage system.
- After disconnecting the service plug grip, wait for at least 5 minutes before touching any of the high-voltage connectors or terminals.

HINT:

At least 5 minutes are required to discharge the high-voltage condenser inside the inverter.

HV

1

CHECK HARNESS AND CONNECTOR (HYBRID VEHICLE CONTROL ECU - INVERTER)

CAUTION:

Wear insulated gloves before performing the following operation.

- Turn the power switch OFF.
- Remove the service plug grip (see page [HB-154](#)).

NOTICE:

Turning the power switch ON (READY) with the service plug grip removed could cause malfunction. Therefore, never turn the power switch ON (READY) in this state.

- Disconnect the H15 HV control ECU connector.
- Remove the inverter cover (see page [HV-531](#)).

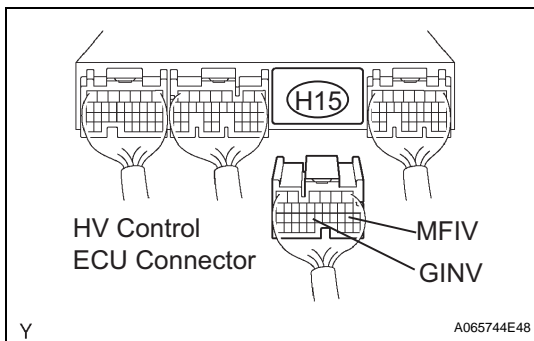

Y

A065744E48

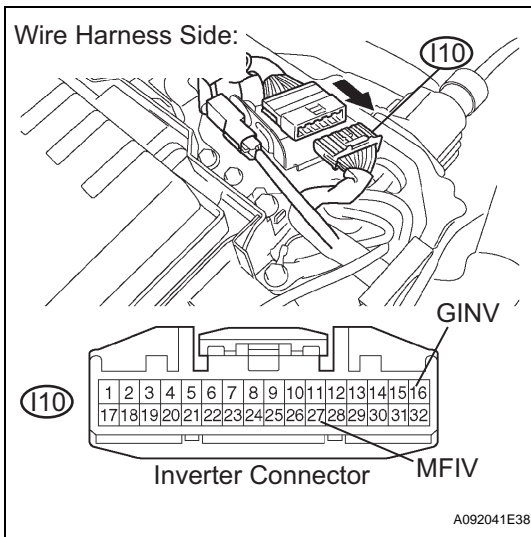

- (e) Disconnect the I10 inverter connector.
- (f) Turn the power switch ON (IG).

HINT:

DTCs for the interlock switch system are output when turning the power switch ON (IG) with both service plug grip and inverter cover removed.

- (g) Measure the voltage between the terminals of the HV control ECU connector and body ground.

Standard voltage

Tester Connection	Specified Condition
MFIV (H15-18) - Body ground	Below 1 V
GINV (H15-23) - Body ground	Below 1 V

- (h) Turn the power switch OFF.
- (i) Measure the resistance between the wire harness side connectors.

Standard resistance (Check for open)

Tester Connection	Specified Condition
MFIV (H15-18) - MFIV (I10-27)	Below 1Ω
GINV (H15-23) - GINV (I10-16)	Below 1 Ω

Standard resistance (Check for short)

Tester Connection	Specified Condition
MFIV (H15-18) or MFIV (I10-27) - Body ground	10 kΩ or higher
GINV (H15-23) or GINV (I10-16) - Body ground	10 kΩ or higher

- (j) Reconnect the inverter connector.
- (k) Reconnect the HV control ECU connector.
- (l) Reinstall the inverter cover (see page [HV-538](#)).
- (m) Reinstall the service plug grip (see page [HB-154](#)).

NG → **REPAIR OR REPLACE HARNESS OR CONNECTOR**

OK

REPLACE INVERTER WITH CONVERTER ASSEMBLY

DTC	P0A78- 284	Drive Motor "A" Inverter Performance
------------	-----------------------	---

DESCRIPTION

See the description of the inverter (see page [HV-220](#)).

If the motor inverter has a circuit malfunction, internal short, or overheats, the inverter transmits that information to the MFIV terminal of the HV control ECU via the motor inverter fail signal line.

DTC No.	INF Code	DTC Detection Condition	Trouble Area
P0A78	284	Motor inverter fail (MFIV) signal detection (inverter overheating)	<ul style="list-style-type: none"> • Wire harness or connector • Inverter cooling system • Water pump with motor assembly • Cooling fan motor • No. 2 cooling fan motor • HV transaxle assembly • Hybrid vehicle motor • HV control ECU • Inverter with converter assembly

MONITOR DESCRIPTION

If the motor inverter overheats, it transmits an inverter fail signal to the HV control ECU. Upon receiving this signal, the HV control ECU illuminates the MIL and sets a DTC.

MONITOR STRATEGY

Related DTCs	P0A78 (INF 284): Motor inverter / MFIV detection over heat
Required sensor / components	Motor inverter
Frequency of operation	Continuous
Duration	TOYOTA's intellectual property
MIL operation	Immediately
Sequence of operation	None

TYPICAL ENABLING CONDITIONS

The monitor will run whenever the following DTCs are not present	TOYOTA's intellectual property
No other condition	-

TYPICAL MALFUNCTION THRESHOLDS

Motor inverter	Overheated
----------------	------------

COMPONENT OPERATING RANGE

Motor inverter	DTC P0A78 (INF 284) is not detected
----------------	-------------------------------------

WIRING DIAGRAM

Refer to DTC P0A78 (INF 279) (see page [HV-235](#)).

INSPECTION PROCEDURE

CAUTION:

- Before inspecting the high-voltage system, take safety precautions to prevent electrical shocks, such as wearing insulated gloves and removing the service plug grip. After removing the service plug grip, put it in your pocket to prevent other technicians from reconnecting it while you are servicing the high-voltage system.
- After disconnecting the service plug grip, wait for at least 5 minutes before touching any of the high-voltage connectors or terminals.

HINT:

At least 5 minutes are required to discharge the high-voltage condenser inside the inverter.

1	READ OUTPUT DTC (HV ECU)
----------	---------------------------------

- (a) Connect the intelligent tester to the DLC3.
- (b) Turn the power switch ON (IG).
- (c) Turn the intelligent tester ON.
- (d) Enter the following menus: DIAGNOSIS / OBD/MOBD / HV ECU / DTC INFO / CURRENT CODES.
- (e) Read DTCs.

Result:

DTCs listed in the table below are output

DTC No.	Relevant Diagnosis
P0A1D	Hybrid Powertrain Control Module
P0A2B, P0A2C or P0A2D	Drive Motor "A" Temperature Sensor Circuit System
P0A37, P0A38 or P0A39	Generator Temperature Sensor Circuit System
P0A3F, P0A40 or P0A41	Drive Motor "A" Position Sensor Circuit System
P0A4B, P0A4C or P0A4D	Generator Position Sensor Circuit System
P0A60 or P0A63	Drive Motor "A" Current Sensor Circuit System
P0A72 or P0A75	Generator Current Sensor Circuit System
P0A78	Drive Motor "A" Inverter Performance
P0A7A	Generator Inverter Performance
P0A90	Drive Motor "A" Performance
P0A92	Hybrid Generator Performance
P0A93	Inverter Cooling System Malfunction
P0A94	DC / DC Converter Malfunction
P0AA1, P0AA4, P0AE0, P0AE6, P0AE7, P0ADB or P0ADF	System Main Relay Circuit System
P0AA6, P3004	High Voltage System
P0AEE	Motor Inverter Temperature Sensor Malfunction
P3000	HV Battery System Malfunction
P3110	Integration Relay Malfunction
P3221	Generator Inverter Temperature Sensor Circuit System
P3226	DC / DC Boost Converter Temperature Sensor Circuit System

HV

YES

GO TO DTC CHART. FIND PAGE NUMBER TO PROCEED TO DIAGNOSTIC TROUBLESHOOTING FLOWCHART

NO

2 CHECK QUANTITY OF HV COOLANT

- (a) Check that there is a sufficient amount of coolant for the inverter.

OK:

There is a sufficient amount of coolant for the inverter

NG

ADD HV COOLANT

OK

3 CHECK COOLANT HOSE

- (a) Check that the hoses of the cooling system are not bent or clogged (refer to the cooling system [see page [HV-346](#)]).

OK:

The hoses of the cooling system are not bent or clogged

NG

CORRECT TO NORMAL CONDITION

OK

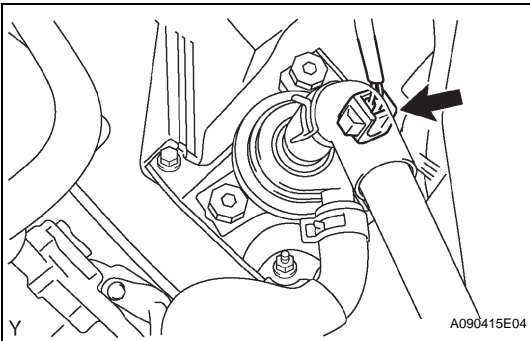
4 CHECK CONNECTION CONDITION OF WATER PUMP CONNECTOR (LOOSENESS AND POOR CONTACT)

- (a) Check the connection condition of the water pump connector.

OK:

Connector has been connected securely and there is no poor connection.

NG

CONNECT SECURELY

OK

5 CHECK WATER PUMP WITH MOTOR ASSEMBLY

- (a) Turn the power switch ON (IG).
(b) Check the operation of the water pump.

OK:

Coolant is sloshing in the reservoir tank

NG

REPLACE WATER PUMP WITH MOTOR ASSEMBLY

HV

OK

6 CHECK CONNECTION CONDITION OF COOLING FAN MOTOR CONNECTOR (LOOSENESS AND POOR CONTACT)

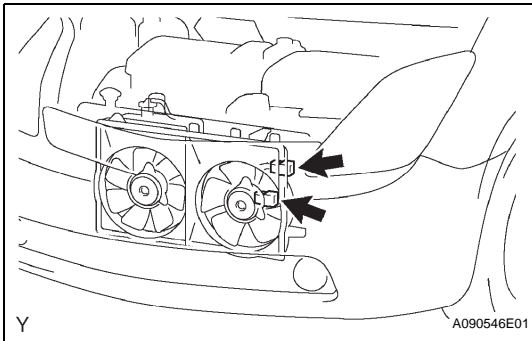

(a) Check the connection condition of the cooling fan motor connectors.

OK:

Connectors have been connected securely and there is no poor connection.

NG

CONNECT SECURELY

OK

7 INSPECT COOLING FAN MOTOR

(a) Inspect the cooling fan motor (see page [CO-5](#)).

NG

REPLACE COOLING FAN MOTOR AND ADD ENGINE COOLANT

OK

8 INSPECT NO. 2 COOLING FAN MOTOR

(a) Inspect the No. 2 cooling fan motor (see page [CO-5](#)).

NG

REPLACE NO. 2 COOLING FAN MOTOR AND ADD ENGINE COOLANT

OK

9 CHECK CONNECTION CONDITION OF HYBRID VEHICLE CONTROL ECU CONNECTOR (LOOSENESS AND POOR CONTACT)

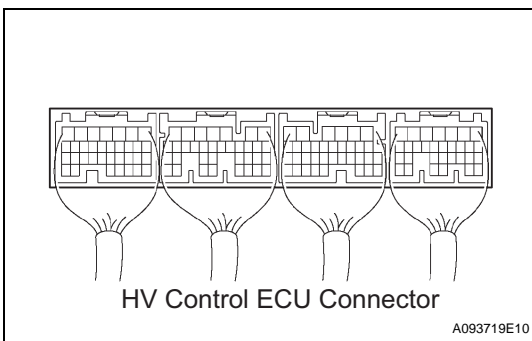

(a) Check the connection condition of all the connectors at the HV control ECU.

OK:

Connectors have been connected securely and there is no poor connection.

NG

CONNECT SECURELY

OK

HV

10 CHECK CONNECTION CONDITION OF INVERTER CONNECTOR (LOOSENESS AND POOR CONTACT)

CAUTION:

Wear insulated gloves before performing the following operation.

- (a) Turn the power switch OFF.
- (b) Remove the service plug grip (see page [HB-154](#)).

NOTICE:

Turning the power switch ON (READY) with the service plug grip removed could cause malfunction. Therefore, never turn the power switch ON (READY) in this state.

- (c) Remove the inverter cover (see page [HV-531](#)).
- (d) Check the connection condition of the I9 and I10 inverter connectors.

OK:

Connectors have been connected securely and there is no poor connection.

- (e) Reinstall the inverter cover (see page [HV-538](#)).
- (f) Reinstall the service plug grip (see page [HB-154](#)).

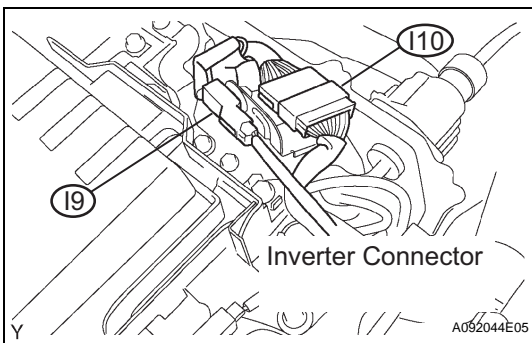

NG **CONNECT SECURELY**

OK

11 CONFIRM INFORMATION (EXCLUSIVE INFO 4)

- (a) Connect the intelligent tester to the DLC3.
- (b) Turn the power switch ON (IG).

HINT:

DTCs for the interlock switch system are output when turning the power switch ON (IG) with both service plug grip and inverter cover removed.

- (c) Turn the intelligent tester ON.
- (d) Enter the following menus: DIAGNOSIS / OBD/MOBD / HV ECU / DTC INFO / CURRENT CODES.
- (e) Select DTC P0A78 to display its freeze frame data.
- (f) Select the item that has INF code 284 from among INFORMATION 1 to 5, and press ENTER.
- (g) Read EXCLUSIVE INFO 4.

Result:

Displayed in Exclusive Information 4	Proceed to
-127 to -120, -95 to -88, -63 to -56, -31 to -24, 1 to 8, 33 to 40, 65 to 72, 97 to 104	A
-119 to -112, -87 to -80, -55 to -48, -23 to -16, 9 to 16, 41 to 48, 73 to 80, 105 to 112	B
-111 to -104, -79 to -72, -47 to -40, -15 to -8, 17 to 24, 49 to 56, 81 to 88, 113 to 120	C
-103 to -96, -71 to -64, -39 to -32, -7 to 0, 25 to 32, 57 to 64, 89 to 96, 121 to 127	D

- B** REPLACE HYBRID VEHICLE CONTROL ECU
- C** REPLACE INVERTER WITH CONVERTER ASSEMBLY
- D** REPLACE HYBRID VEHICLE TRANSAXLE ASSEMBLY

A

12 INSPECT HYBRID VEHICLE MOTOR ASSEMBLY

CAUTION:

Wear insulated gloves before performing the following operation.

- (a) Turn the power switch OFF.
- (b) Remove the service plug grip (see page [HB-154](#)).

NOTICE:

Turning the power switch ON (READY) with the service plug grip removed could cause malfunction. Therefore, never turn the power switch ON (READY) in this state.

- (c) Remove the inverter cover (see page [HV-531](#)).
- (d) Disconnect the three-phase alternating current cable for the hybrid vehicle motor from the inverter.
- (e) Using a milliohm meter, measure the resistance between the three-phase alternating current cable terminals of the hybrid vehicle motor.

NOTICE:

If the motor temperature is too high, the resistance varies considerably, which hinders determining malfunction. Therefore, measure the resistance at a minimum 8 hours after the vehicle has been stopped.

Standard resistance

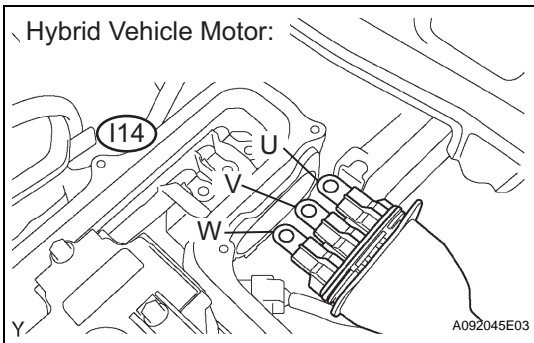

Tester Connection	Specified Condition*
U (I14-1) - V (I14-2)	Below 135 mΩ at 20°C
V (I14-2) - W (I14-3)	Below 135 mΩ at 20°C
W (I14-3) - U (I14-1)	Below 135 mΩ at 20°C

*: Apply the formula given below to correct the resistance.

$$R20 = Rt / \{1 + 0.00393 \times (T - 20)\}$$

R20: Resistance converted to 20°C (mΩ)

Rt: Resistance between measured lines (mΩ)

T: Ambient air temperature during measurement (°C)

- (f) Calculate the difference between the maximum and minimum resistance between terminals U - V, V - W, and W - U.

Standard resistance:

Below 2 mΩ

- (g) Using a megohmmeter, measure the insulation resistance between the three-phase alternating current cable terminals of the hybrid vehicle motor and the body ground.

Standard resistance

Tester Connection	Specified Condition
U (I14-1) - Body ground	10 MΩ or higher
V (I14-2) - Body ground	10 MΩ or higher
W (I14-3) - Body ground	10 MΩ or higher

- (h) Reconnect the three-phase alternating current cable for the hybrid vehicle motor.

NG → **REPLACE HYBRID VEHICLE MOTOR ASSEMBLY**

OK

13 PERFORM ACTIVE TEST BY INTELLIGENT TESTER (INVERTER STOP)

CAUTION:

Wear insulated gloves before performing the following operation.

- (a) Check that the service plug grip and inverter cover have been removed.
- (b) Connect the intelligent tester to the DLC3.
- (c) Turn the power switch ON (IG).

HINT:

DTCs for the interlock switch system are output when turning the power switch ON (IG) with both service plug grip and inverter cover removed.

- (d) Turn the intelligent tester ON.
- (e) Enter the following menus: DIAGNOSIS / OBD/MOBD / HV ECU / ACTIVE TEST.
- (f) Measure the voltage between the terminals of the inverter connector while effecting INVERTER STOP.

Standard voltage

Tester Connection	Specified Condition
MUU (I10-9) - GINV (I10-16)	12 to 16 V
MVU (I10-10) - GINV (I10-16)	12 to 16 V
MWU (I10-11) - GINV (I10-16)	12 to 16 V

- (g) Turn the power switch OFF.

OK → **REPLACE INVERTER WITH CONVERTER ASSEMBLY**

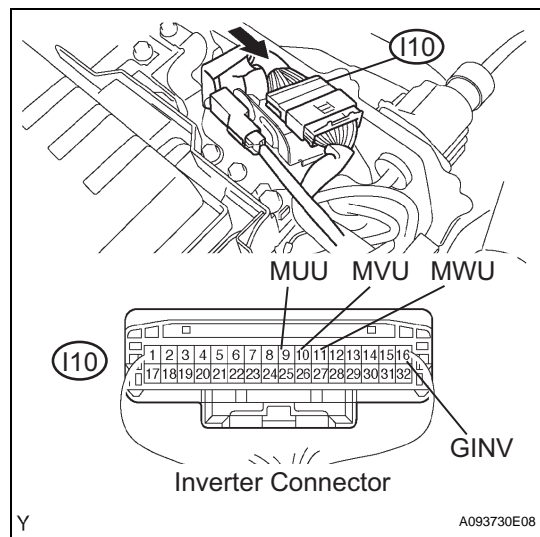

NG

14 PERFORM ACTIVE TEST BY INTELLIGENT TESTER (INVERTER STOP)

CAUTION:

Wear insulated gloves before performing the following operation.

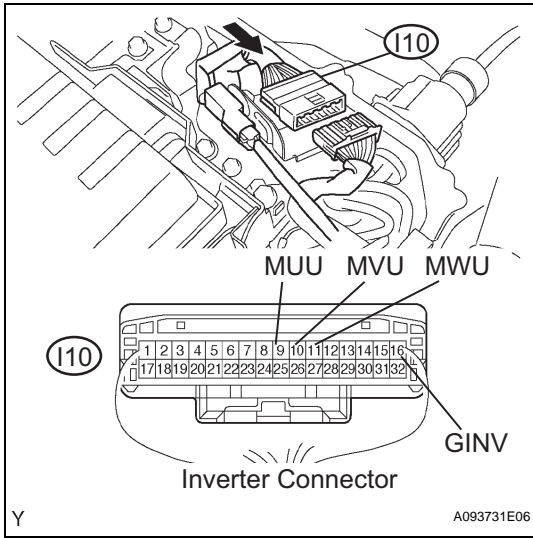

- (a) Check that the service plug grip and inverter cover have been removed.
- (b) Disconnect the I10 inverter connector.
- (c) Connect the intelligent tester to the DLC3.
- (d) Turn the power switch ON (IG).

HINT:

Inverter Connector DTCs for the interlock switch system are output when turning the power switch ON (IG) with both service plug grip and inverter cover removed.

- (e) Turn the intelligent tester ON.
- (f) Enter the following menus: DIAGNOSIS / OBD/MOBD / HV ECU / ACTIVE TEST.
- (g) Measure the voltage between the terminals of the inverter connector while effecting INVERTER STOP.

Standard voltage

Tester Connection	Specified Condition
MUU (I10-9) - GINV (I10-16)	14 to 16 V
MVU (I10-10) - GINV (I10-16)	14 to 16 V
MWU (I10-11) - GINV (I10-16)	14 to 16 V

- (h) Turn the power switch OFF.
- (i) Reconnect the inverter connector.
- (j) Reinstall the inverter cover (see page HV-538).
- (k) Reinstall the service plug grip (see page HB-154).

NG → **REPLACE INVERTER WITH CONVERTER ASSEMBLY**

OK

REPLACE HYBRID VEHICLE CONTROL ECU

DTC	P0A78-286	Drive Motor "A" Inverter Performance
------------	------------------	---

DESCRIPTION

See the description of the inverter (see page [HV-220](#)).

If the motor inverter has a circuit malfunction, internal short, or overheats, the inverter transmits that information to the MFIV terminal of the HV control ECU via the motor inverter fail signal line.

DTC No.	INF Code	DTC Detection Condition	Trouble Area
P0A78	286	Motor inverter fail (MFIV) signal detection (circuit malfunction)	<ul style="list-style-type: none"> • Wire harness or connector • Inverter with converter assembly

MONITOR DESCRIPTION

If the motor inverter detects a circuit malfunction, it transmits a motor inverter fail signal to the HV control ECU. Upon receiving this signal, the HV control ECU illuminates the MIL and sets a DTC.

MONITOR STRATEGY

Related DTCs	P0A78 (INF 286): Motor inverter / MFIV detection circuit malfunction
Required sensor / components	Motor inverter
Frequency of operation	Continuous
Duration	TOYOTA's intellectual property
MIL operation	Immediately
Sequence of operation	None

TYPICAL ENABLING CONDITIONS

The monitor will run whenever the following DTCs are not present	TOYOTA's intellectual property
No other condition	-

TYPICAL MALFUNCTION THRESHOLDS

Motor inverter	Circuit malfunction
----------------	---------------------

COMPONENT OPERATING RANGE

Motor inverter	DTC P0A78 (INF 286) is not detected
----------------	-------------------------------------

WIRING DIAGRAM

Refer to DTC P0A78 (INF 282) (see page [HV-244](#)).

INSPECTION PROCEDURE

CAUTION:

- Before inspecting the high-voltage system, take safety precautions to prevent electrical shocks, such as wearing insulated gloves and removing the service plug grip. After removing the service plug grip, put it in your pocket to prevent other technicians from reconnecting it while you are servicing the high-voltage system.
- After disconnecting the service plug grip, wait for at least 5 minutes before touching any of the high-voltage connectors or terminals.

HINT:

At least 5 minutes are required to discharge the high-voltage condenser inside the inverter.

1 READ OUTPUT DTC (HV ECU)

- (a) Connect the intelligent tester to the DLC3.
- (b) Turn the power switch ON (IG).
- (c) Turn the intelligent tester ON.
- (d) Enter the following menus: DIAGNOSIS / OBD/MOBD / HV ECU / DTC INFO / CURRENT CODES.
- (e) Read DTCs.

Result:

DTC listed in the table below is output

DTC No.	INF Code	Detection Item	See Page
P0A78	283 or 285	Drive Motor "A" Inverter performance	HV-247

YES

GO TO THE PAGE NUMBER SHOWN IN THE TABLE ABOVE

NO

2 CHECK CONNECTION CONDITION OF INVERTER CONNECTOR (LOOSENESS AND POOR CONTACT)

CAUTION:

Wear insulated gloves before performing the following operation.

- (a) Turn the power switch OFF.
- (b) Remove the service plug grip (see page [HB-154](#)).

NOTICE:

Turning the power switch ON (READY) with the service plug grip removed could cause malfunction. Therefore, never turn the power switch ON (READY) in this state.

- (c) Remove the inverter cover (see page [HV-531](#)).
- (d) Check the connection condition of the I9 and I10 inverter connectors.

OK:

Connectors have been connected securely and there is no poor connection.

- (e) Reinstall the inverter cover (see page [HV-538](#)).
- (f) Reinstall the service plug grip (see page [HB-154](#)).

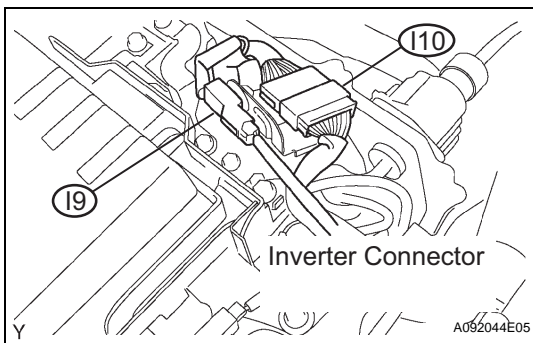

NG

CONNECT SECURELY

OK

3 READ OUTPUT DTC (HV ECU)

- (a) Connect the intelligent tester to the DLC3.
- (b) Turn the power switch ON (IG).

HV

HINT:

DTCs for the interlock switch system are output when turning the power switch ON (IG) with both service plug grip and inverter cover removed.

- (c) Turn the intelligent tester ON.
- (d) Enter the following menus: DIAGNOSIS / OBD/MOBD / HV ECU / DTC INFO / CURRENT CODES.
- (e) Read DTCs.

Result:

DTCs P0A78 (INF 282, 286) and P0A7A (INF 324) (inverter circuit malfunction) are output

NO → **REPLACE INVERTER WITH CONVERTER ASSEMBLY**

YES

4 INSPECT INVERTER WITH CONVERTER ASSEMBLY (IGCT VOLTAGE)

CAUTION:

Wear insulated gloves before performing the following operation.

- (a) Turn the power switch OFF.
- (b) Remove the service plug grip (see page [HB-154](#)).

NOTICE:

Turning the power switch ON (READY) with the service plug grip removed could cause malfunction. Therefore, never turn the power switch ON (READY) in this state.

- (c) Remove the inverter cover (see page [HV-531](#)).
- (d) Turn the power switch ON (IG).

HINT:

DTCs for the interlock switch system are output when turning the power switch ON (IG) with both service plug grip and inverter cover removed.

- (e) Measure the voltage between the terminals of the inverter connector.

Standard voltage

Tester Connection	Specified Condition
IGCT (I9-1) - GND1 (I9-2)	8 V or more

- (f) Turn the power switch OFF.
- (g) Reinstall the inverter cover (see page [HV-538](#)).
- (h) Reinstall the service plug grip (see page [HB-154](#)).

NG → **REPAIR OR REPLACE HARNESS OR CONNECTOR**

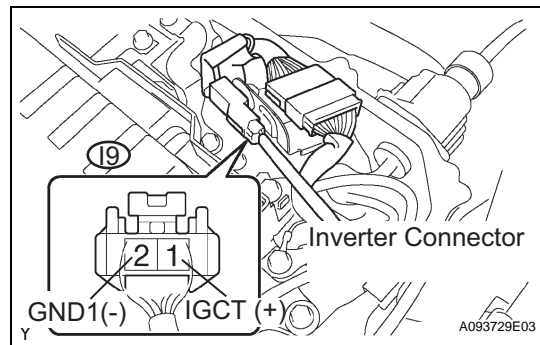

OK

REPLACE INVERTER WITH CONVERTER ASSEMBLY

HV

DTC	P0A78-287	Drive Motor "A" Inverter Performance
DTC	P0A78-505	Drive Motor "A" Inverter Performance
DTC	P0A78-506	Drive Motor "A" Inverter Performance

DESCRIPTION

See the description of the inverter (see page [HV-220](#)).

If the motor inverter has a circuit malfunction, internal short, or overheats, the inverter transmits that information to the MFIV terminal of the HV control ECU via the motor inverter fail signal line.

DTC No.	INF Code	DTC Detection Condition	Trouble Area
P0A78	287	Motor inverter fail (MFIV) signal detection (over current by inverter assembly malfunction)	<ul style="list-style-type: none"> • Wire harness or connector • HV transaxle assembly • Hybrid vehicle motor • HV control ECU • Inverter with converter assembly
P0A78	505	Motor inverter fail (MFIV) signal detection (over current by HV control ECU malfunction)	<ul style="list-style-type: none"> • Wire harness or connector • HV transaxle assembly • Hybrid vehicle motor • HV control ECU • Inverter with converter assembly
P0A78	506	Motor inverter fail (MFIV) signal detection (over current by HV transaxle assembly malfunction)	<ul style="list-style-type: none"> • Wire harness or connector • HV transaxle assembly • Hybrid vehicle motor • HV control ECU • Inverter with converter assembly

HV

MONITOR DESCRIPTION

If over-amperage flows through the motor inverter due to an internal short, the motor inverter transmits an inverter fail signal to the HV control ECU. Upon receiving this signal, the HV control ECU illuminates the MIL and sets a DTC.

MONITOR STRATEGY

Related DTCs	P0A78 (INF 287 / 505 / 506): Motor inverter / MFIV detection over current
Required sensor / components	Motor inverter
Frequency of operation	Continuous
Duration	TOYOTA's intellectual property
MIL operation	Immediately
Sequence of operation	None

TYPICAL ENABLING CONDITIONS

The monitor will run whenever the following DTCs are not present	TOYOTA's intellectual property
No other condition	-

TYPICAL MALFUNCTION THRESHOLDS

Motor inverter	Over current (internal short)
----------------	-------------------------------

COMPONENT OPERATING RANGE

Motor inverter	DTC P0A78 (INF 287 / 505 / 506) is not detected
----------------	---

WIRING DIAGRAM

Refer to DTC P0A78 (INF 279) (see page [HV-235](#)).

INSPECTION PROCEDURE

CAUTION:

- Before inspecting the high-voltage system, take safety precautions to prevent electrical shocks, such as wearing insulated gloves and removing the service plug grip. After removing the service plug grip, put it in your pocket to prevent other technicians from reconnecting it while you are servicing the high-voltage system.
- After disconnecting the service plug grip, wait for at least 5 minutes before touching any of the high-voltage connectors or terminals.

HINT:

At least 5 minutes are required to discharge the high-voltage condenser inside the inverter.

1	READ OUTPUT DTC (HV ECU)
----------	---------------------------------

- Connect the intelligent tester to the DLC3.
- Turn the power switch ON (IG).
- Turn the intelligent tester ON.
- Enter the following menus: DIAGNOSIS / OBD/MOBD / HV ECU / DTC INFO / CURRENT CODES.
- Read DTCs.

Result:

DTCs listed in the table below are output

DTC No.	Relevant Diagnosis
P0A1D	Hybrid Powertrain Control Module
P0A2B, P0A2C or P0A2D	Drive Motor "A" Temperature Sensor Circuit System
P0A37, P0A38 or P0A39	Generator Temperature Sensor Circuit System
P0A3F, P0A40 or P0A4	Drive Motor "A" Position Sensor Circuit System
P0A4B, P0A4C or P0A4D	Generator Position Sensor Circuit System
P0A60 or P0A63	Drive Motor "A" Current Sensor Circuit System
P0A72 or P0A75	Generator Current Sensor Circuit System
P0A78	Drive Motor "A" Inverter Performance
P0A7A	Generator Inverter Performance
P0A90	Drive Motor "A" Performance
P0A92	Hybrid Generator Performance
P0A93	Inverter Cooling System Malfunction
P0A94	DC / DC Converter Malfunction
P0AA1, P0AA4, P0AE0, P0AE6, P0AE7, P0ADB or P0ADF	System Main Relay Circuit System
P0AA6, P3004	High Voltage System
P0AEE	Motor Inverter Temperature Sensor Malfunction
P3000	HV Battery System Malfunction
P3110	Integration Relay Malfunction

DTC No.	Relevant Diagnosis
P3221	Generator Inverter Temperature Sensor Circuit System
P3226	DC / DC Boost Converter Temperature Sensor Circuit System

YES → **GO TO DTC CHART. FIND PAGE NUMBER TO PROCEED TO DIAGNOSTIC TROUBLESHOOTING FLOWCHART**

NO

2 CHECK CONNECTION CONDITION OF HYBRID VEHICLE CONTROL ECU CONNECTOR (LOOSENESS AND POOR CONTACT)

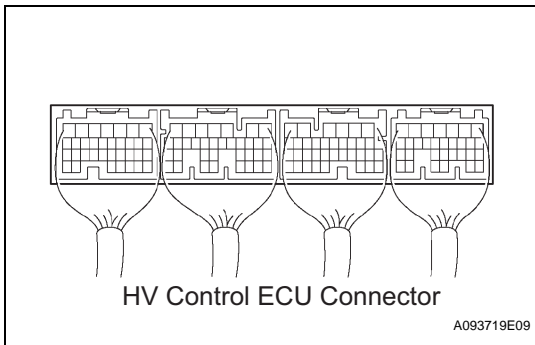

(a) Check the connection condition of all the connectors at the HV control ECU.

OK:

Connectors have been connected securely and there is no poor connection.

NG → **CONNECT SECURELY**

OK

3 CHECK CONNECTION CONDITION OF INVERTER CONNECTOR (LOOSENESS AND POOR CONTACT)

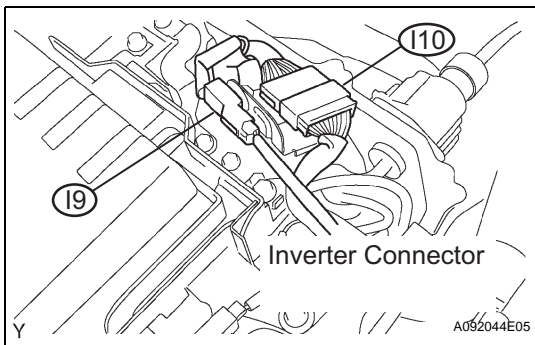

CAUTION:

Wear insulated gloves before performing the following operation.

- (a) Turn the power switch OFF.
- (b) Remove the service plug grip (see page [HB-154](#)).

NOTICE:

Turning the power switch ON (READY) with the service plug grip removed could cause malfunction. Therefore, never turn the power switch ON (READY) in this state.

- (c) Remove the inverter cover (see page [HV-531](#)).
- (d) Check the connection condition of the I9 and I10 inverter connectors.

OK:

Connectors have been connected securely and there is no poor connection.

NG → **CONNECT SECURELY**

OK

4 CHECK HYBRID VEHICLE MOTOR ASSEMBLY

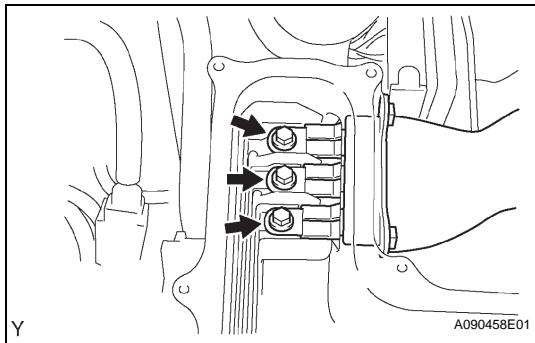

CAUTION:

Wear insulated gloves before performing the following operation.

- (a) Check that the service plug grip and inverter cover have been removed.
- (b) Check if the three-phase alternating current cable installation bolts on the hybrid vehicle motor are tightened to the specified torque.

Torque: 8.0 N*m (82 kgf*cm, 71 in.*lbf)

- (c) Reinstall the inverter cover (see page [HV-538](#)).
- (d) Reinstall the service plug grip (see page [HB-154](#)).

NG **TIGHTEN THEM TO SPECIFIED TORQUE**

OK

5 CONFIRM INFORMATION (EXCLUSIVE INFO 4)

- (a) Connect the intelligent tester to the DLC3.
 - (b) Turn the power switch ON (IG).
- HINT:**
DTCs for the interlock switch system are output when turning the power switch ON (IG) with both service plug grip and inverter cover removed.
- (c) Turn the intelligent tester ON.
 - (d) Enter the following menus: DIAGNOSIS / OBD/MOBD / HV ECU / DTC INFO / CURRENT CODES.
 - (e) Select DTC P0A78 to display its freeze frame data.
 - (f) Select the item that has INF code 287, 505, or 506 from among INFORMATION 1 to 5, and press ENTER.
 - (g) Read EXCLUSIVE INFO 4.

Result:

Displayed in Exclusive Information 4	Proceed to
-127 to -120, -95 to -88, -63 to -56, -31 to -24, 1 to 8, 33 to 40, 65 to 72, 97 to 104	A
-119 to -112, -87 to -80, -55 to -48, -23 to -16, 9 to 16, 41 to 48, 73 to 80, 105 to 112	B
-111 to -104, -79 to -72, -47 to -40, -15 to -8, 17 to 24, 49 to 56, 81 to 88, 113 to 120	C
-103 to -96, -71 to -64, -39 to -32, -7 to 0, 25 to 32, 57 to 64, 89 to 96, 121 to 127	D

B **REPLACE HYBRID VEHICLE CONTROL ECU**

C **REPLACE INVERTER WITH CONVERTER ASSEMBLY**

D **REPLACE HYBRID VEHICLE TRANSAXLE ASSEMBLY**

A

6 INSPECT HYBRID VEHICLE MOTOR ASSEMBLY

CAUTION:

Wear insulated gloves before performing the following operation.

- (a) Turn the power switch OFF.
- (b) Remove the service plug grip (see page [HB-154](#)).

NOTICE:

Turning the power switch ON (READY) with the service plug grip removed could cause malfunction. Therefore, never turn the power switch ON (READY) in this state.

- (c) Remove the inverter cover (see page [HV-531](#)).
- (d) Disconnect the three-phase alternating current cable for the hybrid vehicle motor from the inverter.
- (e) Using a milliohm meter, measure the resistance between the three-phase alternating current cable terminals of the hybrid vehicle motor.

NOTICE:

If the motor temperature is too high, the resistance varies considerably, which hinders determining malfunction. Therefore, measure the resistance at a minimum 8 hours after the vehicle has been stopped.

Standard resistance

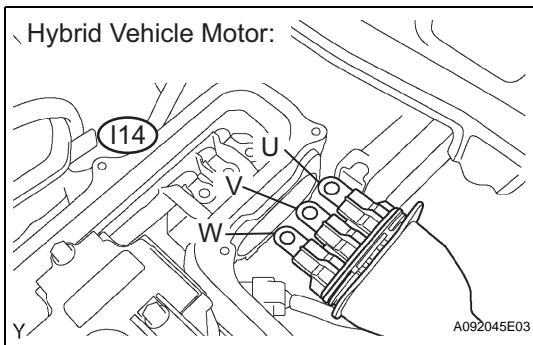

Tester Connection	Specified Condition*
U (I14-1) - V (I14-2)	Below 135 mΩ at 20°C
V (I14-2) - W (I14-3)	Below 135 mΩ at 20°C
W (I14-3) - U (I14-1)	Below 135 mΩ at 20°C

HV

*: Apply the formula given below to correct the resistance.

$$R_{20} = R_t / \{ (1 + 0.00393 \times (T - 20)) \}$$

R_t: Resistance between measured lines (mΩ)

R₂₀: Resistance converted to 20°C (mΩ)

T: Ambient air temperature during measurement (°C)

- (f) Calculate the difference between the maximum and minimum resistance between terminals U - V, V - W, and W - U.

Standard resistance:

Below 2 mΩ

- (g) Using a megohmmeter, measure the insulation resistance between the three-phase alternating current cable terminals of the hybrid vehicle motor and the body ground.

Standard resistance

Tester Connection	Specified Condition
U (I14-1) - Body ground	10 MΩ or higher
V (I14-2) - Body ground	10 MΩ or higher
W (I14-3) - Body ground	10 MΩ or higher

- (h) Reconnect the three-phase alternating current cable for the hybrid vehicle motor.

NG → **REPLACE HYBRID VEHICLE MOTOR ASSEMBLY**

OK

7 **PERFORM ACTIVE TEST BY INTELLIGENT TESTER (INVERTER STOP)**

CAUTION:

Wear insulated gloves before performing the following operation.

- (a) Check that the service plug grip and inverter cover have been removed.
- (b) Connect the intelligent tester to the DLC3.
- (c) Turn the power switch ON (IG).

HINT:

DTCs for the interlock switch system are output when turning the power switch ON (IG) with both service plug grip and inverter cover removed.

- (d) Turn the intelligent tester ON.
- (e) Enter the following menus: DIAGNOSIS / OBD/MOBD / HV ECU / ACTIVE TEST.
- (f) Measure the voltage between the terminals of the inverter connector while effecting INVERTER STOP.

Standard voltage

Tester Connection	Specified Condition
MUU (I10-9) - GINV (I10-16)	12 to 16 V
MVU (I10-10) - GINV (I10-16)	12 to 16 V
MWU (I10-11) - GINV (I10-16)	12 to 16 V

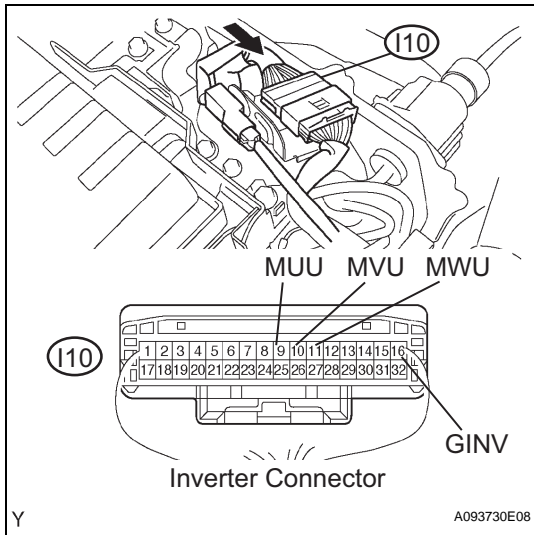

- (g) Turn the power switch OFF.

OK → **REPLACE INVERTER WITH CONVERTER ASSEMBLY**

NG

8 **PERFORM ACTIVE TEST BY INTELLIGENT TESTER (INVERTER STOP)**

CAUTION:

Wear insulated gloves before performing the following operation.

- (a) Check that the service plug grip and inverter cover have been removed.

HV

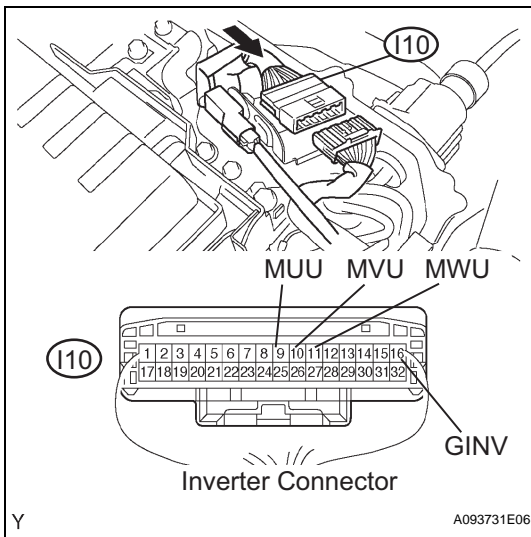

- (b) Disconnect the I10 inverter connector.
- (c) Connect the intelligent tester to the DLC3.
- (d) Turn the power switch ON (IG).

HINT:

DTCs for the interlock switch system are output when turning the power switch ON (IG) with both service plug grip and inverter cover removed.

- (e) Turn the intelligent tester ON.
- (f) Enter the following menus: DIAGNOSIS / OBD/MOBD / HV ECU / ACTIVE TEST.
- (g) Measure the voltage between the terminals of the inverter connector while effecting INVERTER STOP.

Standard voltage

Tester Connection	Specified Condition
MUU (I10-9) - GINV (I10-16)	14 to 16 V
MVU (I10-10) - GINV (I10-16)	14 to 16 V
MWU (I10-11) - GINV (I10-16)	14 to 16 V

- (h) Turn the power switch OFF.
- (i) Reconnect the inverter connector.
- (j) Reinstall the inverter cover (see page [HV-538](#)).
- (k) Reinstall the service plug grip (see page [HB-154](#)).

NG → **REPLACE INVERTER WITH CONVERTER ASSEMBLY**

OK

REPLACE HYBRID VEHICLE CONTROL ECU

DTC	P0A78-304	Drive Motor "A" Inverter Performance
DTC	P0A78-305	Drive Motor "A" Inverter Performance
DTC	P0A78-507	Drive Motor "A" Inverter Performance

DESCRIPTION

See the description of the inverter (see page [HV-220](#)).

Upon receiving a motor gate shutdown signal from the HV control ECU, the inverter forcefully stops the operation of the MG2 by turning OFF the power transistors that are actuating the MG2.

The HV control ECU monitors the motor gate shutdown signal line and detects a malfunction.

DTC No.	INF Code	DTC Detection Condition	Trouble Area
P0A78	304	Open or +B short in motor gate shutdown (MSDN) signal circuit	<ul style="list-style-type: none"> Wire harness or connector Inverter with converter assembly
P0A78	305	GND short in motor gate shutdown (MSDN) signal circuit	<ul style="list-style-type: none"> Wire harness or connector Inverter with converter assembly
P0A78	507	Open in motor gate shutdown (MSDN) signal circuit	<ul style="list-style-type: none"> Wire harness or connector Inverter with converter assembly

MONITOR DESCRIPTION

The HV control ECU monitors the motor gate shutdown (MSDN) signal line. If the HV control ECU detects an open or short malfunction of the MSDN signal circuit, the HV control ECU illuminates the MIL and sets a DTC.

MONITOR STRATEGY

Related DTCs	P0A78 (INF 304 / 305 / 507): Motor inverter / Motor gate shutdown signal malfunction
Required sensor / components	Motor inverter
Frequency of operation	Continuous
Duration	TOYOTA's intellectual property
MIL operation	1 driving cycle
Sequence of operation	None

TYPICAL ENABLING CONDITIONS

The monitor will run whenever the following DTCs are not present	TOYOTA's intellectual property
Other conditions belong to TOYOTA's intellectual property	-

TYPICAL MALFUNCTION THRESHOLDS

Motor gate shutdown signal circuit	Open or short
------------------------------------	---------------

COMPONENT OPERATING RANGE

Motor inverter

DTC P0A78 (INF 304 / 305 / 507) is not detected

WIRING DIAGRAM

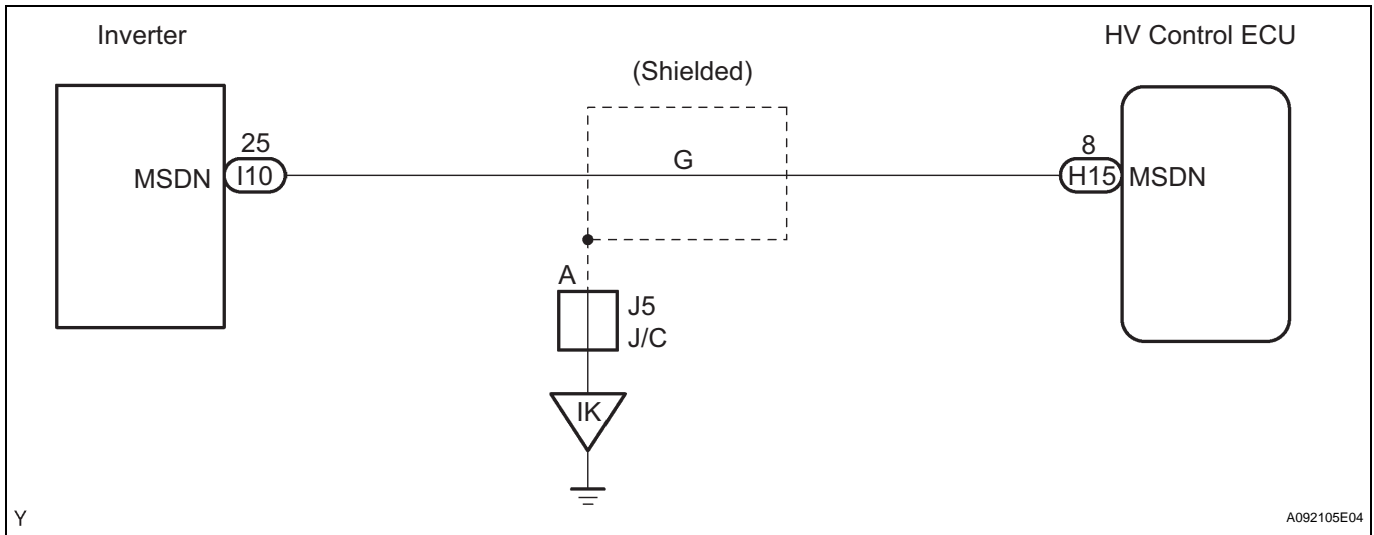

INSPECTION PROCEDURE

CAUTION:

- Before inspecting the high-voltage system, take safety precautions to prevent electrical shocks, such as wearing insulated gloves and removing the service plug grip. After removing the service plug grip, put it in your pocket to prevent other technicians from reconnecting it while you are servicing the high-voltage system.
- After disconnecting the service plug grip, wait for at least 5 minutes before touching any of the high-voltage connectors or terminals.

HINT:

At least 5 minutes are required to discharge the high-voltage condenser inside the inverter.

HV
1
CHECK HARNESS AND CONNECTOR (HYBRID VEHICLE CONTROL ECU - INVERTER)

CAUTION:

Wear insulated gloves before performing the following operation.

- Turn the power switch OFF.
- Remove the service plug grip (see page [HB-154](#)).

NOTICE:

Turning the power switch ON (READY) with the service plug grip removed could cause malfunction. Therefore, never turn the power switch ON (READY) in this state.

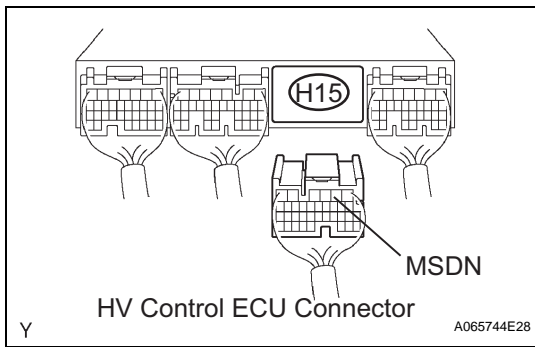

- (c) Disconnect the H15 HV control ECU connector.
- (d) Remove the inverter cover (see page HV-531).
- (e) Disconnect the I10 inverter connector.

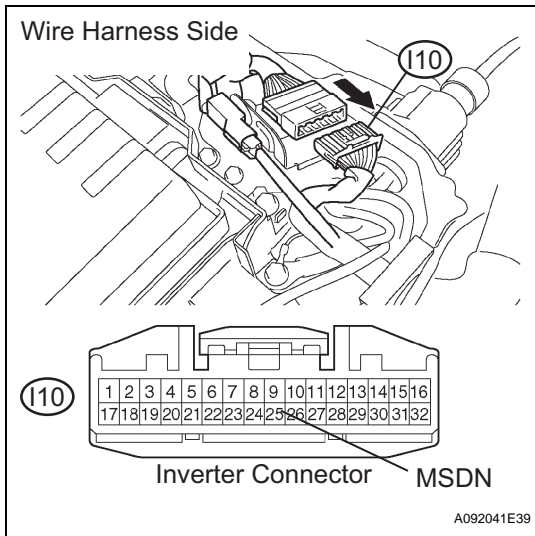

- (f) Turn the power switch ON (IG).
HINT:
DTCs for the interlock switch system are output when turning the power switch ON (IG) with both service plug grip and inverter cover removed.
- (g) Measure the voltage between the terminal of the HV control ECU connector and body ground.

Standard voltage

Tester Connection	Specified Condition
MSDN (H15-8) - Body ground	Below 1 V

- (h) Turn the power switch OFF.
- (i) Measure the resistance between the wire harness side connectors.

Standard resistance (Check for open)

Tester Connection	Specified Condition
MSDN (H15-8) - MSDN (I10-25)	Below 1 Ω

Standard resistance (Check for short)

Tester Connection	Specified Condition
MSDN (H15-8) or MSDN (I10-25) - Body ground	10 kΩ or higher

- (j) Reconnect the inverter connector.
- (k) Reconnect the HV control ECU connector.
- (l) Reinstall the inverter cover (see page HV-538).
- (m) Reinstall the service plug grip (see page HB-154).

NG → **REPAIR OR REPLACE HARNESS OR CONNECTOR**

OK

REPLACE INVERTER WITH CONVERTER ASSEMBLY

DTC	P0A78-306	Drive Motor "A" Inverter Performance
------------	------------------	---

DESCRIPTION

See the description of the inverter (see page [HV-220](#)).

The HV control ECU controls MG2 torque in accordance with the driving condition.

DTC No.	INF Code	DTC Detection Condition	Trouble Area
P0A78	306	Failure in monitoring MG2 torque performance	<ul style="list-style-type: none"> • Hybrid vehicle motor • Inverter with converter assembly

MONITOR DESCRIPTION

If the difference between the requested MG2 torque and the actual MG2 torque exceeds a predetermined value, the HV control ECU determines that there is malfunction in the execution or monitoring of the MG2 torque. Then, the HV control ECU illuminates the MIL and sets a DTC.

MONITOR STRATEGY

Related DTCs	P0A78 (INF 306): Discrepancy between motor monitored torque and commanded torque
Required sensor / components	Motor inverter
Frequency of operation	Continuous
Duration	TOYOTA's intellectual property
MIL operation	Immediately
Sequence of operation	None

TYPICAL ENABLING CONDITIONS

The monitor will run whenever the following DTCs are not present	TOYOTA's intellectual property
No other condition	-

HV

TYPICAL MALFUNCTION THRESHOLDS

Difference between demanded and actual MG2 torque	Exceeds the standard level
---	----------------------------

COMPONENT OPERATING RANGE

Motor inverter	DTC P0A78 (INF 306) is not detected
----------------	-------------------------------------

INSPECTION PROCEDURE

CAUTION:

- **Before inspecting the high-voltage system, take safety precautions to prevent electrical shocks, such as wearing insulated gloves and removing the service plug grip. After removing the service plug grip, put it in your pocket to prevent other technicians from reconnecting it while you are servicing the high-voltage system.**
- **After disconnecting the service plug grip, wait for at least 5 minutes before touching any of the high-voltage connectors or terminals.**

HINT:

At least 5 minutes are required to discharge the high-voltage condenser inside the inverter.

1 READ OUTPUT DTC (HV ECU)

- (a) Connect the intelligent tester to the DLC3.
- (b) Turn the power switch ON (IG).
- (c) Turn the intelligent tester ON.
- (d) Enter the following menus: DIAGNOSIS / OBD/MOBD / HV ECU / DTC INFO / CURRENT CODES.
- (e) Read DTCs.

Result:

DTC P0A78 (INF 306) and other DTCs are output

HINT:

If any other codes besides P0A78 (INF 306) are output, perform troubleshooting for those DTCs first.

YES → **GO TO RELEVANT DTC CHART**

NO

2 INSPECT HYBRID VEHICLE MOTOR ASSEMBLY

CAUTION:

Wear insulated gloves before performing the following operation.

- (a) Turn the power switch OFF.
- (b) Remove the service plug grip (see page [HB-154](#)).

NOTICE:

Turning the power switch ON (READY) with the service plug grip removed could cause malfunction. Therefore, never turn the power switch ON (READY) in this state.

- (c) Remove the inverter cover (see page [HV-531](#)).
- (d) Disconnect the three-phase alternating current cable for the hybrid vehicle motor from the inverter.
- (e) Using a milliohm meter, measure the resistance between the three-phase alternating current cable terminals of the hybrid vehicle motor.

NOTICE:

If the motor temperature is too high, the resistance varies considerably, which hinders determining malfunction. Therefore, measure the resistance at a minimum 8 hours after the vehicle has been stopped.

Standard resistance

Tester Connection	Specified Condition*
U (I14-1) - V (I14-2)	Below 135 mΩ at 20°C
V (I14-2) - W (I14-3)	Below 135 mΩ at 20°C
W (I14-3) - U (I14-1)	Below 135 mΩ at 20°C

*: Apply the formula given below to correct the resistance.

$$R20 = Rt / \{1 + 0.00393 \times (T - 20)\}$$

R20: Resistance converted to 20°C (mΩ)

Rt: Resistance between measured lines (mΩ)

HV

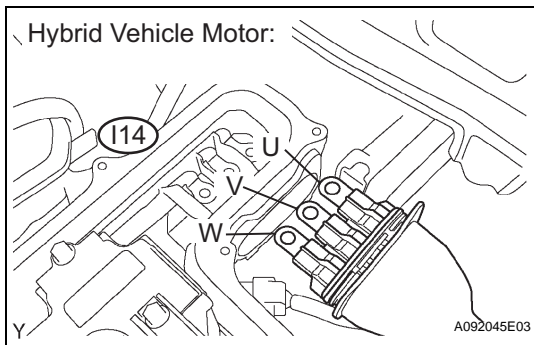

- T: Ambient air temperature during measurement (°C)
- (f) Calculate the difference between the maximum and minimum resistance between terminals U - V, V - W, and W - U.

Standard resistance:

Below 2 mΩ

- (g) Using a megohmmeter, measure the insulation resistance between the three-phase alternating current cable terminals of the hybrid vehicle motor and the body ground.

Standard resistance

Tester Connection	Specified Condition
U (I14-1) - Body ground	10 MΩ or higher
V (I14-2) - Body ground	10 MΩ or higher
W (I14-3) - Body ground	10 MΩ or higher

- (h) Reconnect the three-phase alternating current cable for the hybrid vehicle motor.
- (i) Reinstall the inverter cover (see page [HV-538](#)).
- (j) Reinstall the service plug grip (see page [HB-154](#)).

NG **REPLACE HYBRID VEHICLE MOTOR ASSEMBLY**

OK

REPLACE INVERTER WITH CONVERTER ASSEMBLY

DTC	P0A78-308	Drive Motor "A" Inverter Performance
------------	------------------	---

DESCRIPTION

The HV control ECU receives a collision signal from the center airbag sensor and the No. 1 circuit breaker sensor to determine that the vehicle has been damaged. Then, it cuts off the high-voltage system to ensure safety. If the HV control ECU receives the collision signal only from the center airbag sensor, it turns OFF the system main relay and the power switch. If the HV control ECU receives the collision signal only from the No. 1 circuit breaker sensor, it turns only the system main relay OFF.

DTC No.	INF Code	DTC Detection Condition	Trouble Area
P0A78	308	Collision signal input from center airbag sensor or No. 1 circuit breaker sensor	<ul style="list-style-type: none"> Supplemental restraint system No. 1 circuit breaker sensor

INSPECTION PROCEDURE

1	CHECK VEHICLE FOR ANY DAMAGE
----------	-------------------------------------

(a) Check the vehicle for any damage.

Result:

The vehicle is damaged.

YES	REPAIR VEHICLE
------------	-----------------------

NO

2	GO TO SUPPLEMENTAL RESTRAINT SYSTEM
----------	--

(a) Troubleshoot the airbag system.

Result:

There is malfunction in the airbag system.

NO	REPLACE NO. 1 CIRCUIT BREAKER SENSOR
-----------	---

YES

REPAIR MALFUNCTIONING PARTS AND COMPONENTS

HV

DTC	P0A78-508	Drive Motor "A" Inverter Performance
------------	------------------	---

DESCRIPTION

See the description of the inverter (see page [HV-220](#)).

Upon receiving a motor gate shutdown signal from the HV control ECU, the inverter forcefully stops the operation of the MG2 by turning OFF the power transistors that are actuating the MG2.

The HV control ECU monitors the motor gate shutdown signal and detects a malfunction.

DTC No.	INF Code	DTC Detection Condition	Trouble Area
P0A78	508	Motor gate shutdown (MSDN) signal malfunction	<ul style="list-style-type: none"> • Wire harness or connector • HV control ECU

MONITOR DESCRIPTION

The HV control ECU monitors the motor gate shutdown (MSDN) signal. If the HV control ECU detects a fault in the MSDN signal, it illuminates the MIL and sets a DTC.

MONITOR STRATEGY

Related DTCs	P0A78 (INF 508): Motor inverter shutdown signal line malfunction
Required sensor / components	Motor inverter
Frequency of operation	Continuous
Duration	TOYOTA's intellectual property
MIL operation	Immediately
Sequence of operation	None

TYPICAL ENABLING CONDITIONS

The monitor will run whenever the following DTCs are not present	TOYOTA's intellectual property
Other conditions belong to TOYOTA's intellectual property	-

HV

TYPICAL MALFUNCTION THRESHOLDS

Actual status of shutdown command signal and its monitoring result	Inconsistent
--	--------------

COMPONENT OPERATING RANGE

Motor inverter	DTC P0A78 (INF 508) is not detected
----------------	-------------------------------------

WIRING DIAGRAM

Refer to DTC P0A78 (INF 304) (see page [HV-269](#)).

INSPECTION PROCEDURE

CAUTION:

- Before inspecting the high-voltage system, take safety precautions to prevent electrical shocks, such as wearing insulated gloves and removing the service plug grip. After removing the service plug grip, put it in your pocket to prevent other technicians from reconnecting it while you are servicing the high-voltage system.
- After disconnecting the service plug grip, wait for at least 5 minutes before touching any of the high-voltage connectors or terminals.

HINT:

At least 5 minutes are required to discharge the high-voltage condenser inside the inverter.

1 READ OUTPUT DTC (HV ECU)

- (a) Connect the intelligent tester to the DLC3.
- (b) Turn the power switch ON (IG).
- (c) Turn the intelligent tester ON.
- (d) Enter the following menus: DIAGNOSIS / OBD/MOBD / HV ECU / DTC INFO / CURRENT CODES.
- (e) Read DTCs.

Result:

DTC P0A78 (INF 508) and other DTCs are output

HINT:

If any other codes besides P0A78 (INF 508) are output, perform troubleshooting for those DTCs first.

YES

GO TO RELEVANT DTC CHART

NO

2 CHECK HARNESS AND CONNECTOR (HYBRID VEHICLE CONTROL ECU - INVERTER)

CAUTION:

Wear insulated gloves before performing the following operation.

- (a) Turn the power switch OFF.
- (b) Remove the service plug grip (see page [HB-154](#)).

NOTICE:

Turning the power switch ON (READY) with the service plug grip removed could cause malfunction. Therefore, never turn the power switch ON (READY) in this state.

- (c) Disconnect the H15 HV control ECU connector.
- (d) Remove the inverter cover (see page [HV-531](#)).

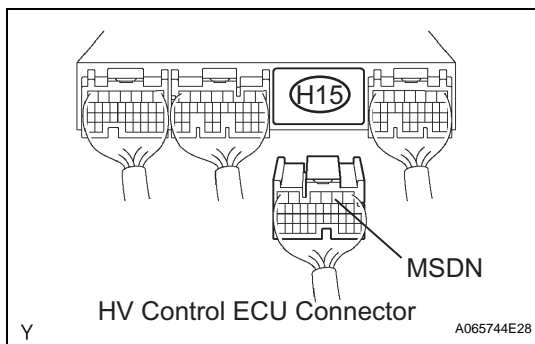

HV

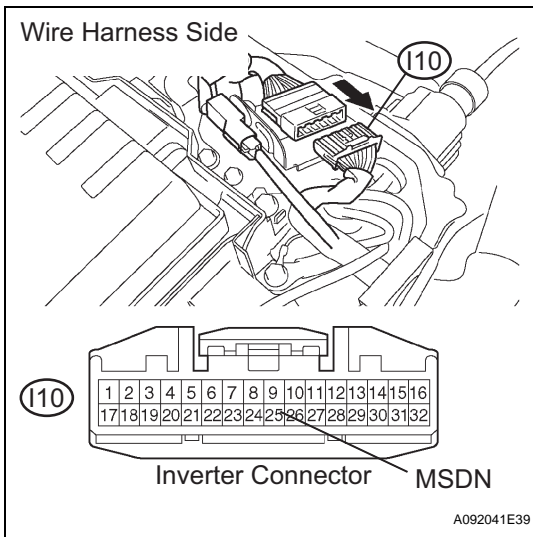

- (e) Disconnect the I10 inverter connector.
HINT:
DTCs for the interlock switch system are output when turning the power switch ON (IG) with both service plug grip and inverter cover removed.
- (f) Turn the power switch ON (IG).
- (g) Measure the voltage between the terminal of the H15 HV control ECU connector and body ground.

Standard voltage

Tester Connection	Specified Condition
MSDN (H15-8) - Body ground	Below 1 V

- (h) Turn the power switch OFF.
- (i) Measure the resistance between the wire harness side connectors.

Standard resistance (Check for open)

Tester Connection	Specified Condition
MSDN (H15-8) - MSDN (I10-25)	Below 1 Ω

Standard resistance (Check for short)

Tester Connection	Specified Condition
MSDN (H15-8) or MSDN (I10-25) - Body ground	10 kΩ or higher

- (j) Reconnect the inverter connector.
- (k) Reconnect the HV control ECU connector.
- (l) Reinstall the inverter cover (see page [HV-538](#)).
- (m) Reinstall the service plug grip (see page [HB-154](#)).

NG	REPAIR OR REPLACE HARNESS OR CONNECTOR
-----------	---

OK

REPLACE HYBRID VEHICLE CONTROL ECU

DTC	P0A78-510	Drive Motor "A" Inverter Performance
------------	------------------	---

DESCRIPTION

See the description of the inverter (see page [HV-220](#)).

Upon receiving a motor gate shutdown signal from the HV control ECU, the inverter forcefully stops the operation of the MG2 by turning OFF the power transistors that are actuating the MG2.

The HV control ECU monitors the motor gate shutdown signal and detects a malfunction.

DTC No.	INF Code	DTC Detection Condition	Trouble Area
P0A78	510	Motor inverter gate malfunction	<ul style="list-style-type: none"> • Wire harness or connector • Inverter with converter assembly

WIRING DIAGRAM

Refer to DTC P0A78 (INF 304) (see page [HV-269](#)).

INSPECTION PROCEDURE

CAUTION:

- Before inspecting the high-voltage system, take safety precautions to prevent electrical shocks, such as wearing insulated gloves and removing the service plug grip. After removing the service plug grip, put it in your pocket to prevent other technicians from reconnecting it while you are servicing the high-voltage system.
- After disconnecting the service plug grip, wait for at least 5 minutes before touching any of the high-voltage connectors or terminals.

HINT:

At least 5 minutes are required to discharge the high-voltage condenser inside the inverter.

HV

1 CHECK HARNESS AND CONNECTOR (HYBRID VEHICLE CONTROL ECU - INVERTER)

CAUTION:

Wear insulated gloves before performing the following operation.

- (a) Turn the power switch OFF.
- (b) Remove the service plug grip (see page [HB-154](#)).

NOTICE:

Turning the power switch ON (READY) with the service plug grip removed could cause malfunction. Therefore, never turn the power switch ON (READY) in this state.

- (c) Disconnect the H15 HV control ECU connector.
- (d) Remove the inverter cover (see page [HV-531](#)).

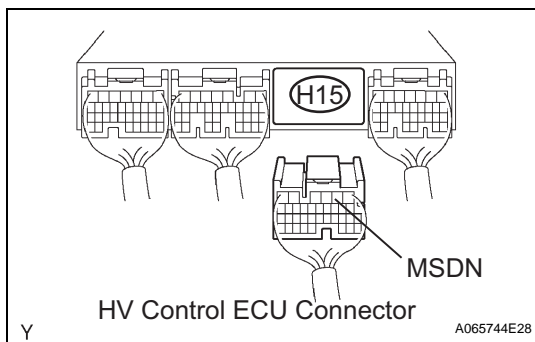

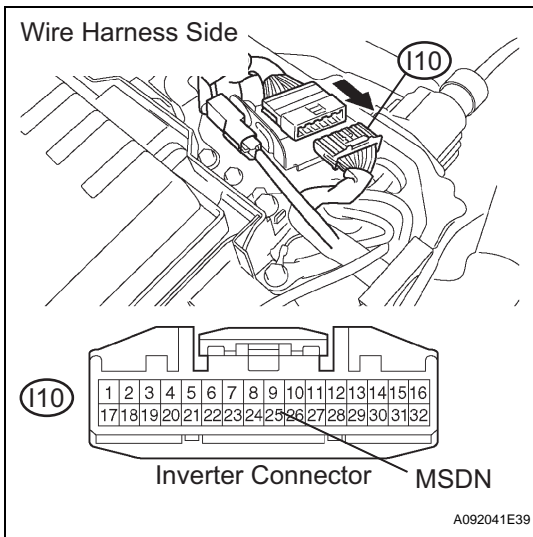

- (e) Disconnect the I10 inverter connector.
- (f) Turn the power switch ON (IG).
HINT:
DTCs for the interlock switch system are output when turning the power switch ON (IG) with both service plug grip and inverter cover removed.
- (g) Measure the voltage between the terminal of the H15 HV control ECU connector and body ground.

Standard voltage

Tester Connection	Specified Condition
MSDN (H15-8) - Body ground	Below 1 V

- (h) Turn the power switch OFF.
- (i) Measure the resistance between the wire harness side connectors.

Standard resistance (Check for open)

Tester Connection	Specified Condition
MSDN (H15-8) - MSDN (I10-25)	Below 1 Ω

Standard resistance (Check for short)

Tester Connection	Specified Condition
MSDN (H15-8) or MSDN (I10-25) - Body ground	10 kΩ or higher

- (j) Reconnect the inverter connector.
- (k) Reconnect the HV control ECU connector.
- (l) Reinstall the inverter cover (see page [HV-538](#)).
- (m) Reinstall the service plug grip (see page [HB-154](#)).

NG	REPAIR OR REPLACE HARNESS OR CONNECTOR
-----------	---

OK

REPLACE INVERTER WITH CONVERTER ASSEMBLY

DTC	P0A78-523	Drive Motor "A" Inverter Performance
------------	------------------	---

DESCRIPTION

Refer to DTC P0A78 (INF 266) (see page [HV-220](#)).

DTC No.	INF Code	DTC Detection Condition	Trouble Area
P0A78	523	Inverter voltage (VH) sensor offset malfunction	<ul style="list-style-type: none"> System main relay Inverter with converter assembly

MONITOR DESCRIPTION

The HV control ECU monitors the inverter voltage (VH) sensor signal. If the HV control ECU detects a fault in the sensor signal, the HV control ECU interprets this as a VH sensor failure. The HV control ECU then illuminates the MIL and sets a DTC.

MONITOR STRATEGY

Related DTCs	P0A78 (INF 523): Voltage (VH) malfunction
Required sensor / components	Motor inverter, battery ECU
Frequency of operation	Continuous
Duration	TOYOTA's intellectual property
MIL operation	Immediately
Sequence of operation	None

TYPICAL ENABLING CONDITIONS

The monitor will run whenever the following DTCs are not present	TOYOTA's intellectual property
Other conditions belong to TOYOTA's intellectual property	-

TYPICAL MALFUNCTION THRESHOLDS

TOYOTA's intellectual property	-
--------------------------------	---

COMPONENT OPERATING RANGE

Motor inverter	DTC P0A78 (INF 523) is not detected
----------------	-------------------------------------

INSPECTION PROCEDURE

CAUTION:

- Before inspecting the high-voltage system, take safety precautions to prevent electrical shocks, such as wearing insulated gloves and removing the service plug grip. After removing the service plug grip, put it in your pocket to prevent other technicians from reconnecting it while you are servicing the high-voltage system.
- After disconnecting the service plug grip, wait for at least 5 minutes before touching any of the high-voltage connectors or terminals.

HINT:

At least 5 minutes are required to discharge the high-voltage condenser inside the inverter.

1 READ OUTPUT DTC (HV ECU)

- (a) Connect the intelligent tester to the DLC3.
- (b) Turn the power switch ON (IG).
- (c) Turn the intelligent tester ON.
- (d) Enter the following menus: DIAGNOSIS / OBD/MOBD / HV ECU / DTC INFO / CURRENT CODES.
- (e) Read DTCs.

Result:

DTC P0A78 (INF 523) and other DTCs are output

HINT:

If any other codes besides P0A78 (INF 523) are output, perform troubleshooting for those DTCs first.

YES**GO TO RELEVANT DTC CHART****NO****2 CHECK SYSTEM MAIN RELAYS FOR STICKING****CAUTION:**

Wear insulated gloves before performing the following operation.

- (a) Turn the power switch OFF.
- (b) Remove the service plug grip (see page [HB-154](#)).

NOTICE:

Turning the power switch ON (READY) with the service plug grip removed could cause malfunction. Therefore, never turn the power switch ON (READY) in this state.

- (c) Disconnect all the high-voltage terminals of the system main relays.
- (d) Measure the resistance at the switch side of the system main relays.

Standard resistance:

10 kΩ or higher

- (e) Connect the high-voltage terminals of the system main relays.
- (f) Reinstall the service plug grip (see page [HB-154](#)).

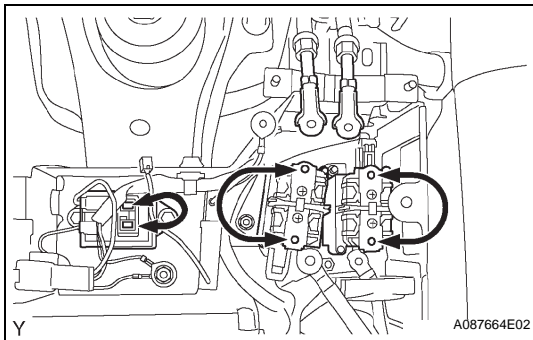
**NG****REPLACE STUCK SYSTEM MAIN RELAY****OK****REPLACE INVERTER WITH CONVERTER ASSEMBLY****HV**

DTC	P0A78-586	Drive Motor "A" Inverter Performance
------------	------------------	---

DESCRIPTION

Refer to DTC P0A78 (INF 266) (see page [HV-220](#)).

DTC No.	INF Code	DTC Detection Condition	Trouble Area
P0A78	586	Inverter voltage (VH) sensor performance problem	<ul style="list-style-type: none"> Wire harness or connector Inverter with converter assembly

MONITOR DESCRIPTION

The HV control ECU monitors the inverter voltage (VH) sensor signal. If the HV control ECU detects a fault in the sensor signal, the HV control ECU interprets this as a VH sensor failure. The HV control ECU then illuminates the MIL and sets a DTC.

MONITOR STRATEGY

Related DTCs	P0A78 (INF 586): Voltage (VH) sensor deviation
Required sensor / components	Motor inverter, battery ECU
Frequency of operation	Continuous
Duration	TOYOTA's intellectual property
MIL operation	Immediately
Sequence of operation	None

TYPICAL ENABLING CONDITIONS

The monitor will run whenever the following DTCs are not present	TOYOTA's intellectual property
Other conditions belong to TOYOTA's intellectual property	-

TYPICAL MALFUNCTION THRESHOLDS

TOYOTA's intellectual property	-
--------------------------------	---

COMPONENT OPERATING RANGE

Motor inverter	DTC P0A78 (INF 586) is not detected
----------------	-------------------------------------

WIRING DIAGRAM

Refer to DTC P0A78 (INF 266) (see page [HV-223](#)).

INSPECTION PROCEDURE

CAUTION:

- Before inspecting the high-voltage system, take safety precautions to prevent electrical shocks, such as wearing insulated gloves and removing the service plug grip. After removing the service plug grip, put it in your pocket to prevent other technicians from reconnecting it while you are servicing the high-voltage system.
- After disconnecting the service plug grip, wait for at least 5 minutes before touching any of the high-voltage connectors or terminals.

HINT:

At least 5 minutes are required to discharge the high-voltage condenser inside the inverter.

1 READ OUTPUT DTC (HV ECU)

- (a) Connect the intelligent tester to the DLC3.
- (b) Turn the power switch ON (IG).
- (c) Turn the intelligent tester ON.
- (d) Enter the following menus: DIAGNOSIS / OBD/MOBD / HV ECU / DTC INFO / CURRENT CODES.
- (e) Read DTCs.

Result:

DTC P0A78 (INF 586) and other DTCs are output

HINT:

If any other codes besides P0A78 (INF 586) are output, perform troubleshooting for those DTCs first.

YES**GO TO RELEVANT DTC CHART****NO****2 CHECK HARNESS AND CONNECTOR (HYBRID VEHICLE CONTROL ECU - INVERTER)****CAUTION:**

Wear insulated gloves before performing the following operation.

- (a) Turn the power switch OFF.
- (b) Remove the service plug grip (see page [HB-154](#)).

NOTICE:

Turning the power switch ON (READY) with the service plug grip removed could cause malfunction. Therefore, never turn the power switch ON (READY) in this state.

- (c) Disconnect the H15 HV control ECU connector.
- (d) Remove the inverter cover (see page [HV-531](#)).

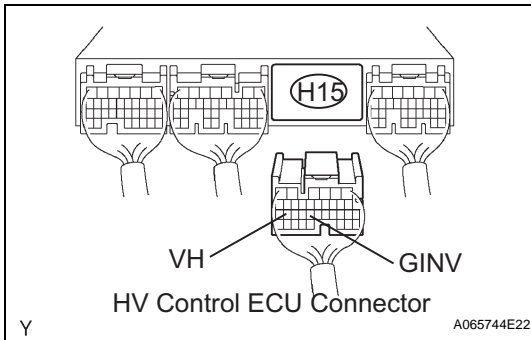
**HV**

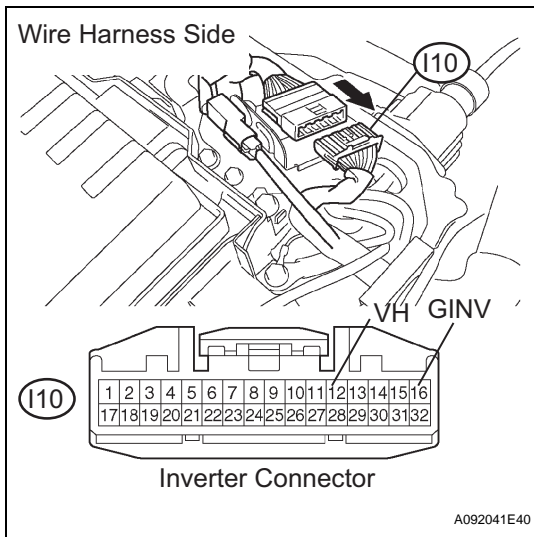

- (e) Disconnect the I10 inverter connector.
- (f) Turn the power switch ON (IG).
HINT:
DTCs for the interlock switch system are output when turning the power switch ON (IG) with both service plug grip and inverter cover removed.
- (g) Measure the voltage between the terminals of the HV control ECU connector and body ground.

Standard voltage

Tester Connection	Specified Condition
VH (H15-26) - Body ground	Below 1 V
GINV (H15-23) - Body ground	Below 1 V

- (h) Turn the power switch OFF.
- (i) Measure the resistance between the wire harness side connectors.

Standard resistance (Check for open)

Tester Connection	Specified Condition
VH (H15-26) - VH (I10-12)	Below 1 Ω
GINV (H15-23) - GINV (I10-16)	Below 1 Ω

Standard resistance (Check for short)

Tester Connection	Specified Condition
VH (H15-26) or VH (I10-12) - Body ground	10 kΩ or higher
GINV (H15-23) or GINV (I10-16) - Body ground	10 kΩ or higher

- (j) Reconnect the inverter connector.
- (k) Reconnect the HV control ECU connector.
- (l) Reinstall the inverter cover (see page [HV-538](#)).
- (m) Reinstall the service plug grip (see page [HB-154](#)).

NG

REPAIR OR REPLACE HARNESS OR CONNECTOR

OK

REPLACE INVERTER WITH CONVERTER ASSEMBLY

HV

DTC	P0A7A-309	Generator Inverter Performance
------------	------------------	---------------------------------------

DESCRIPTION

Refer to DTC P0A78 (INF 272) (see page [HV-228](#)).

DTC No.	INF Code	DTC Detection Condition	Trouble Area
P0A7A	309	Abnormality in generator PWM circuit	<ul style="list-style-type: none"> • Wire harness or connector • Inverter with converter assembly

MONITOR DESCRIPTION

The HV control ECU monitors the generator PWM circuit. If there is an error in the power transistor actuation signals which are transmitted to the inverter, the HV control ECU interprets this as a malfunction of the generator PWM circuit.

The HV control ECU illuminates the MIL and sets a DTC.

MONITOR STRATEGY

Related DTCs	P0A7A (INF 309): Generator PWM malfunction
Required sensor / components	Generator inverter
Frequency of operation	Continuous
Duration	TOYOTA's intellectual property
MIL operation	1 driving cycle
Sequence of operation	None

TYPICAL ENABLING CONDITIONS

The monitor will run whenever the following DTCs are not present	TOYOTA's intellectual property
Other conditions belong to TOYOTA's intellectual property	-

HV**TYPICAL MALFUNCTION THRESHOLDS**

Power transistor actuation signal	Abnormal
-----------------------------------	----------

COMPONENT OPERATING RANGE

Generator inverter	DTC P0A7A (INF 309) is not detected
--------------------	-------------------------------------

WIRING DIAGRAM

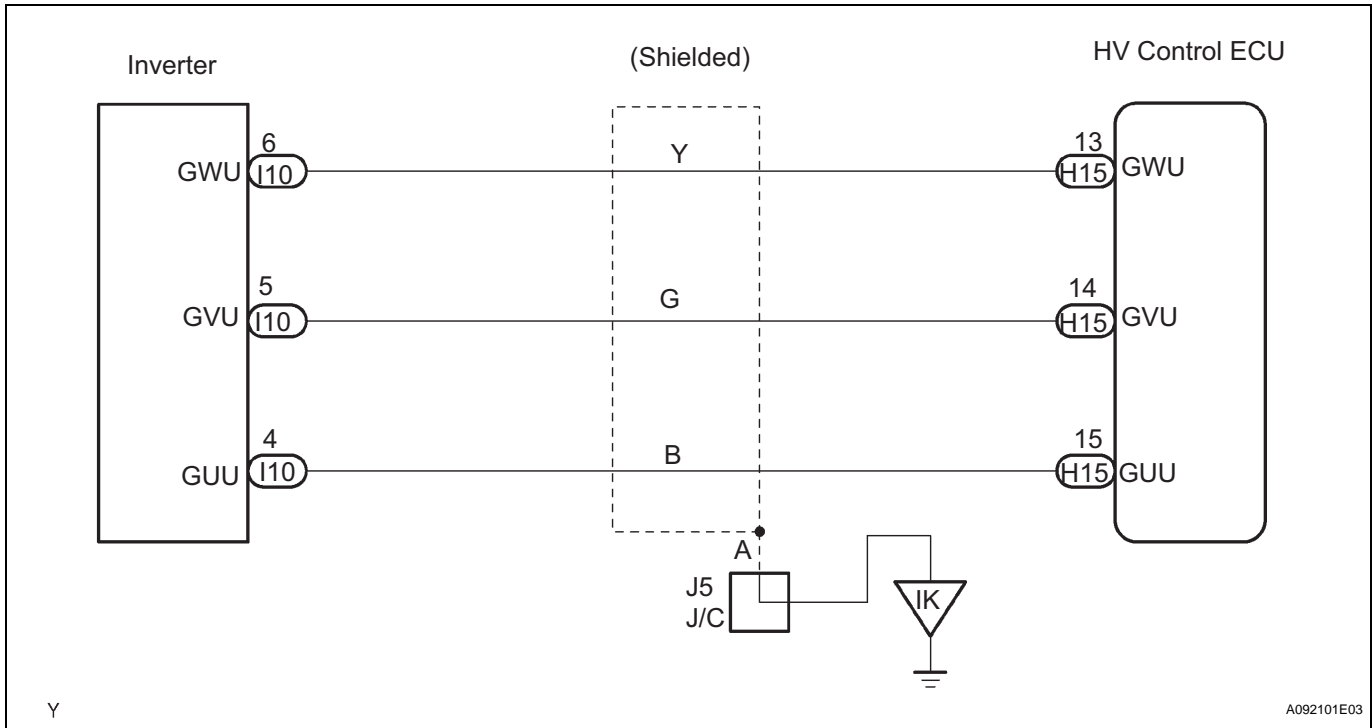

INSPECTION PROCEDURE

CAUTION:

- Before inspecting the high-voltage system, take safety precautions to prevent electrical shocks, such as wearing insulated gloves and removing the service plug grip. After removing the service plug grip, put it in your pocket to prevent other technicians from reconnecting it while you are servicing the high-voltage system.
- After disconnecting the service plug grip, wait for at least 5 minutes before touching any of the high-voltage connectors or terminals.

HINT:

At least 5 minutes are required to discharge the high-voltage condenser inside the inverter.

1	READ OUTPUT DTC (HV ECU)
----------	---------------------------------

- Connect the intelligent tester to the DLC3.
- Turn the power switch ON (IG).
- Turn the intelligent tester ON.
- Enter the following menus: DIAGNOSIS / OBD/MOBD / HV ECU / DTC INFO / CURRENT CODES.
- Read DTCs.

Result:

DTC P0A1D is output

YES
GO TO RELEVANT DTC CHART

NO

HV

2 CHECK HARNESS AND CONNECTOR (HYBRID VEHICLE CONTROL ECU - INVERTER)

CAUTION:

Wear insulated gloves before performing the following operation.

- (a) Turn the power switch OFF.
- (b) Remove the service plug grip (see page [HB-154](#)).

NOTICE:

Turning the power switch ON (READY) with the service plug grip removed could cause malfunction. Therefore, never turn the power switch ON (READY) in this state.

- (c) Remove the inverter cover (see page [HV-531](#)).
- (d) Disconnect the H15 HV control ECU connector.

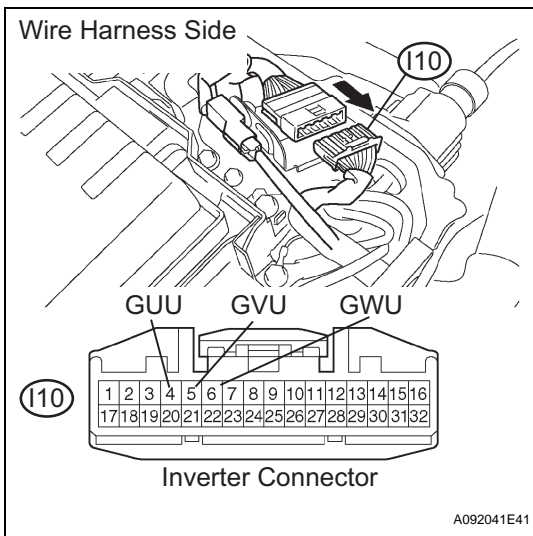
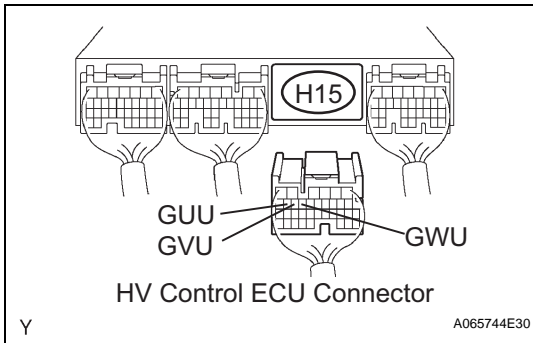

- (e) Disconnect the I10 inverter connector.
- (f) Measure the resistance between the wire harness side connectors.

Standard resistance (Check for open)

Tester Connection	Specified Condition
GUU (H15-15) - GUU (I10-4)	Below 1 Ω
GUV (H15-14) - GUV (I10-5)	Below 1 Ω
GWU (H15-13) - GWU (I10-6)	Below 1 Ω

Standard resistance (Check for short)

Tester Connection	Specified Condition
GUU (H15-15) or GUU (I10-4) - Body ground	10 kΩ or higher
GUV (H15-14) or GUV (I10-5) - Body ground	10 kΩ or higher
GWU (H15-13) or GWU (I10-6) - Body ground	10 kΩ or higher

- (g) Reconnect the inverter connector.
- (h) Reconnect the HV control ECU connector.
- (i) Reinstall the inverter cover (see page [HV-538](#)).
- (j) Reinstall the service plug grip (see page [HB-154](#)).

NG REPAIR OR REPLACE HARNESS OR CONNECTOR

OK

REPLACE INVERTER WITH CONVERTER ASSEMBLY

HV

DTC	P0A7A-321	Generator Inverter Performance
------------	------------------	---------------------------------------

DTC	P0A7A-323	Generator Inverter Performance
------------	------------------	---------------------------------------

DESCRIPTION

See the description of the inverter (see page [HV-220](#)).

If the generator inverter has a circuit malfunction, internal short, or overheats, the inverter transmits that information to the GFIV terminal of the HV control ECU via the generator inverter fail signal line.

The HV control ECU monitors the generator inverter fail signal line and detects a malfunction.

DTC No.	INF Code	DTC Detection Condition	Trouble Area
P0A7A	321	+B short in generator inverter fail (GFIV) signal circuit	<ul style="list-style-type: none"> Wire harness or connector Inverter with converter assembly
P0A7A	323	Open or GND short in generator inverter fail (GFIV) signal circuit	<ul style="list-style-type: none"> Wire harness or connector Inverter with converter assembly

MONITOR DESCRIPTION

The HV control ECU monitors the generator inverter fail (GFIV) signal line. If the HV control ECU detects an open or short malfunction of the GFIV signal circuit, the HV control ECU illuminates the MIL and sets a DTC.

MONITOR STRATEGY

Related DTCs	P0A7A (INF 321 / 323): Generator inverter Finv detection
Required sensor / components	Generator Inverter
Frequency of operation	Continuous
Duration	TOYOTA's intellectual property
MIL operation	1 driving cycle
Sequence of operation	None

TYPICAL ENABLING CONDITIONS

The monitor will run whenever the following DTCs are not present	TOYOTA's intellectual property
Other conditions belong to TOYOTA's intellectual property	-

TYPICAL MALFUNCTION THRESHOLDS

Generator inverter fail signal circuit	Open or short
--	---------------

COMPONENT OPERATING RANGE

Generator inverter	DTC P0A7A (INF 321 / 323) is not detected
--------------------	---

WIRING DIAGRAM

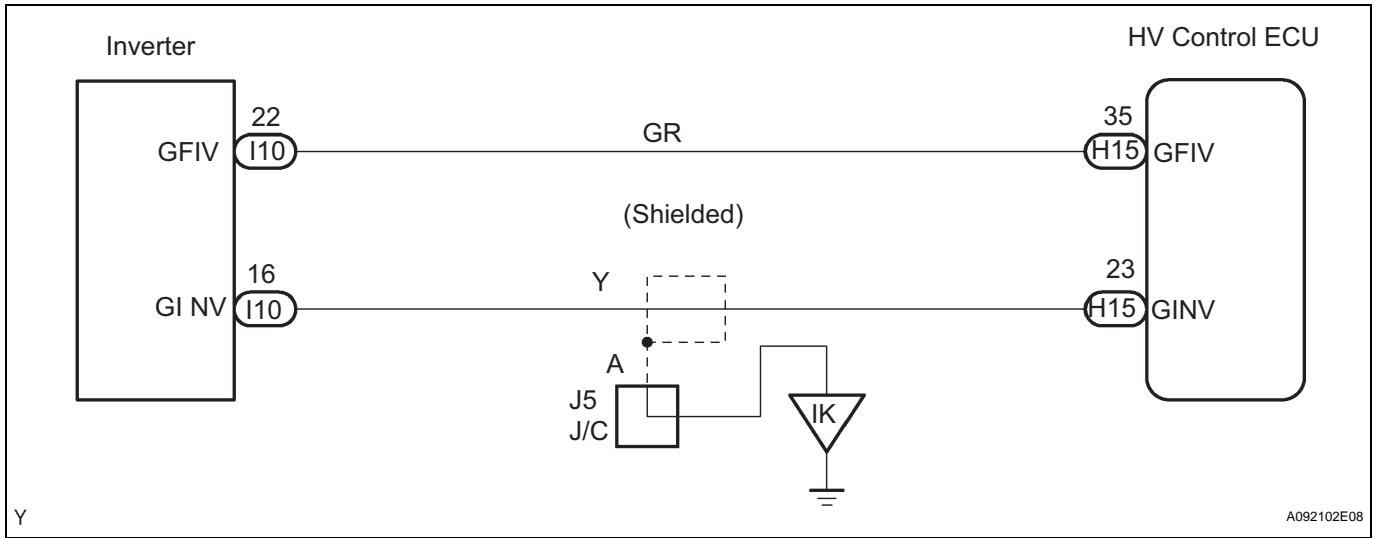

INSPECTION PROCEDURE

CAUTION:

- Before inspecting the high-voltage system, take safety precautions to prevent electrical shocks, such as wearing insulated gloves and removing the service plug grip. After removing the service plug grip, put it in your pocket to prevent other technicians from reconnecting it while you are servicing the high-voltage system.
- After disconnecting the service plug grip, wait for at least 5 minutes before touching any of the high-voltage connectors or terminals.

HINT:

At least 5 minutes are required to discharge the high-voltage condenser inside the inverter.

1 CHECK HARNESS AND CONNECTOR (HYBRID VEHICLE CONTROL ECU - INVERTER)

HV

CAUTION:

Wear insulated gloves before performing the following operation.

- Turn the power switch OFF.
- Remove the service plug grip (see page [HB-154](#)).

NOTICE:

Turning the power switch ON (READY) with the service plug grip removed could cause malfunction. Therefore, never turn the power switch ON (READY) in this state.

- Disconnect the H15 HV control ECU connector.
- Remove the inverter cover (see page [HV-531](#)).

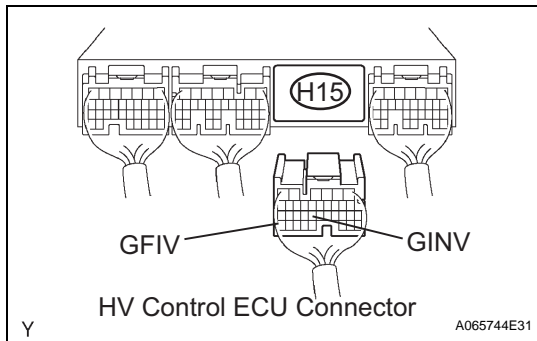

Y

A065744E31

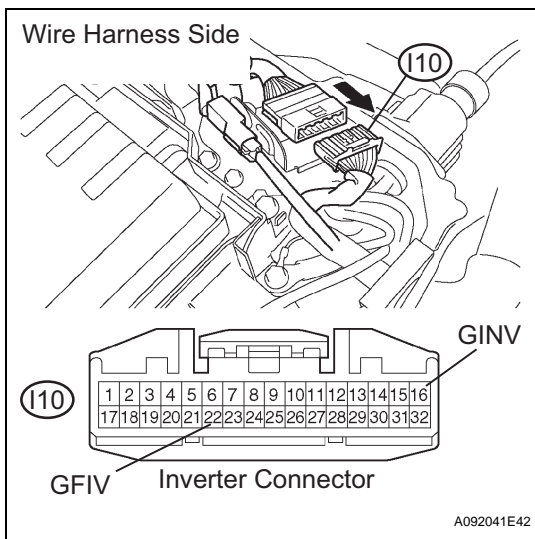

- (e) Disconnect the I10 inverter connector.
- (f) Turn the power switch ON (IG).
HINT:
DTCs for the interlock switch system are output when turning the power switch ON (IG) with both service plug grip and inverter cover removed.
- (g) Measure the voltage between the terminals of the HV control ECU connector and body ground.

Standard voltage

Tester Connection	Specified Condition
GFIV (H15-35) - Body ground	Below 1 V
GINV (H15-23) - Body ground	Below 1 V

- (h) Turn the power switch OFF.
- (i) Measure the resistance between the wire harness side connectors.

Standard resistance (Check for open)

Tester Connection	Specified Condition
GFIV (H15-35) - GFIV (I10-22)	Below 1 Ω
GINV (H15-23) - GINV (I10-16)	Below 1 Ω

Standard resistance (Check for short)

Tester Connection	Specified Condition
GFIV (H15-35) or GFIV (I10-22) - Body ground	10 kΩ or higher
GINV (H15-23) or GINV (I10-16) - Body ground	10 kΩ or higher

- (j) Reconnect the inverter connector.
- (k) Reconnect the HV control ECU connector.
- (l) Reinstall the inverter cover (see page HV-538).
- (m) Reinstall the service plug grip (see page HB-154).

NG

REPAIR OR REPLACE HARNESS OR CONNECTOR

OK

REPLACE INVERTER WITH CONVERTER ASSEMBLY

HV

DTC	P0A7A-322	Generator Inverter Performance
------------	------------------	---------------------------------------

DESCRIPTION

See the description of the inverter (see page [HV-220](#)).

If the generator inverter has a circuit malfunction, internal short, or overheats, the inverter transmits that information to the GFIV terminal of HV control ECU via the generator inverter fail signal line.

DTC No.	INF Code	DTC Detection Condition	Trouble Area
P0A7A	322	Generator inverter fail (GFIV) signal detection (inverter overheating)	<ul style="list-style-type: none"> • Wire harness or connector • Inverter cooling system • Water pump with motor assembly • Cooling fan motor • No. 2 cooling fan motor • HV transaxle assembly • Hybrid vehicle generator • HV control ECU • Inverter with converter assembly

MONITOR DESCRIPTION

If the generator inverter overheats, it transmits an inverter fail signal to the HV control ECU. Upon receiving this signal, the HV control ECU illuminates the MIL and sets a DTC.

MONITOR STRATEGY

Related DTCs	P0A7A (INF 322): Generator inverter / GFIV detection over heat
Required sensor / components	Generator inverter
Frequency of operation	Continuous
Duration	TOYOTA's intellectual property
MIL operation	Immediately
Sequence of operation	None

HV

TYPICAL ENABLING CONDITIONS

The monitor will run whenever the following DTCs are not present	TOYOTA's intellectual property
No other condition	-

TYPICAL MALFUNCTION THRESHOLDS

Generator inverter	Overheated
--------------------	------------

COMPONENT OPERATING RANGE

Generator inverter	DTC P0A7A (INF 322) is not detected
--------------------	-------------------------------------

WIRING DIAGRAM

Refer to DTC P0A78 (INF 279) (see page [HV-235](#)).

INSPECTION PROCEDURE

CAUTION:

- Before inspecting the high-voltage system, take safety precautions to prevent electrical shocks, such as wearing insulated gloves and removing the service plug grip. After removing the service plug grip, put it in your pocket to prevent other technicians from reconnecting it while you are servicing the high-voltage system.
- After disconnecting the service plug grip, wait for at least 5 minutes before touching any of the high-voltage connectors or terminals.

HINT:

At least 5 minutes are required to discharge the high-voltage condenser inside the inverter.

1	READ OUTPUT DTC (HV ECU)
----------	---------------------------------

- (a) Connect the intelligent tester to the DLC3.
- (b) Turn the power switch ON (IG).
- (c) Turn the intelligent tester ON.
- (d) Enter the following menus: DIAGNOSIS / OBD/MOBD / HV ECU / DTC INFO / CURRENT CODES.
- (e) Read DTCs.

Result:

DTCs listed in the table below are output

DTC No.	Relevant Diagnosis
P0A1D	Hybrid Powertrain Control Module
P0A2B, P0A2C or P0A2D	Drive Motor "A" Temperature Sensor Circuit System
P0A37, P0A38 or P0A39	Generator Temperature Sensor Circuit System
P0A3F, P0A40 or P0A4	Drive Motor "A" Position Sensor Circuit System
P0A4B, P0A4C or P0A4D	Generator Position Sensor Circuit System
P0A60 or P0A63	Drive Motor "A" Current Sensor Circuit System
P0A72 or P0A75	Generator Current Sensor Circuit System
P0A78	Drive Motor "A" Inverter Performance
P0A7A	Generator Inverter Performance
P0A90	Drive Motor "A" Performance
P0A92	Hybrid Generator Performance
P0A93	Inverter Cooling System Malfunction
P0A94	DC / DC Converter Malfunction
P0AA1, P0AA4, P0AE0, P0AE6, P0AE7, P0ADB or P0ADF	System Main Relay Circuit System
P0AA6, P3004	High Voltage System
P0AEE	Motor Inverter Temperature Sensor Malfunction
P3000	HV Battery System Malfunction
P3110	Integration Relay Malfunction
P3221	Generator Inverter Temperature Sensor Circuit System
P3226	DC / DC Boost Converter Temperature Sensor Circuit System

HV

YES

GO TO DTC CHART. FIND PAGE NUMBER TO PROCEED TO DIAGNOSTIC TROUBLESHOOTING FLOWCHART

NO

2 CHECK QUANTITY OF HV COOLANT

- (a) Check that there is a sufficient amount of coolant for the inverter.

OK:

There is a sufficient amount of coolant for the inverter

NG

ADD HV COOLANT

OK

3 CHECK COOLANT HOSE

- (a) Check that the hoses of the cooling system are not bent or clogged (refer to the cooling system [see page [HV-346](#)]).

OK:

The hoses of the cooling system are not bent or clogged

NG

CORRECT TO NORMAL CONDITION

OK

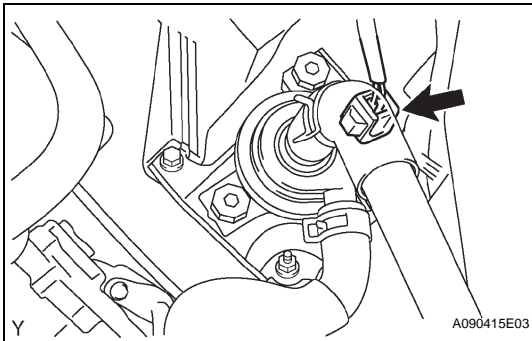
4 CHECK CONNECTION CONDITION OF WATER PUMP CONNECTOR (LOOSENESS AND POOR CONTACT)

- (a) Check the connection condition of the water pump connector.

OK:

Connector has been connected securely and there is no poor connection.

NG

CONNECT SECURELY

OK

5 CHECK WATER PUMP WITH MOTOR ASSEMBLY

- (a) Turn the power switch ON (IG).
(b) Check the operation of the water pump.

OK:

Coolant is sloshing in the reservoir tank

NG

REPLACE WATER PUMP WITH MOTOR ASSEMBLY

HV

OK

6 CHECK CONNECTION CONDITION OF COOLING FAN MOTOR CONNECTOR (LOOSENESS AND POOR CONTACT)

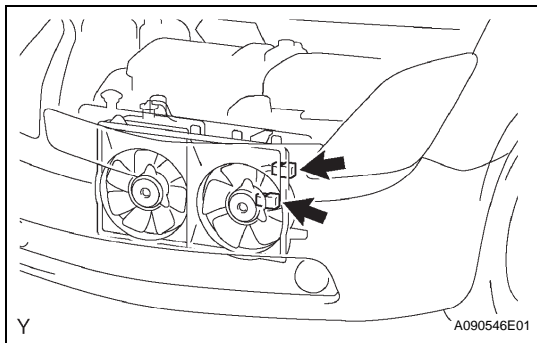

(a) Check the connection condition of the cooling fan motor connectors.

OK:

Connectors have been connected securely and there is no poor connection.

NG **CONNECT SECURELY**

OK

7 INSPECT COOLING FAN MOTOR

(a) Inspect the cooling fan motor (see page [CO-5](#)).

NG **REPLACE COOLING FAN MOTOR AND ADD ENGINE COOLANT**

OK

8 INSPECT NO. 2 COOLING FAN MOTOR

(a) Inspect the No. 2 cooling fan motor (see page [CO-5](#)).

NG **REPLACE NO. 2 COOLING FAN MOTOR AND ADD ENGINE COOLANT**

OK

9 CHECK CONNECTION CONDITION OF HYBRID VEHICLE CONTROL ECU CONNECTOR (LOOSENESS AND POOR CONTACT)

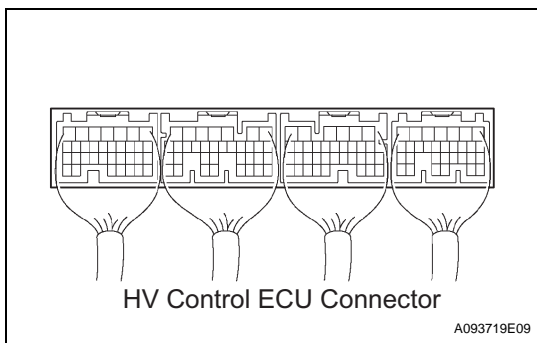

(a) Check the connection condition of all the connectors at the HV control ECU.

OK:

Connectors have been connected securely and there is no poor connection.

NG **CONNECT SECURELY**

OK

HV

10 CHECK CONNECTION CONDITION OF INVERTER CONNECTOR (LOOSENESS AND POOR CONTACT)

CAUTION:

Wear insulated gloves before performing the following operation.

- (a) Turn the power switch OFF.
- (b) Remove the service plug grip (see page [HB-154](#)).

NOTICE:

Turning the power switch ON (READY) with the service plug grip removed could cause malfunction. Therefore, never turn the power switch ON (READY) in this state.

- (c) Remove the inverter cover (see page [HV-531](#)).
- (d) Check the connection condition of the I9 and I10 inverter connectors.

OK:

Connectors have been connected securely and there is no poor connection.

- (e) Reinstall the inverter cover (see page [HV-538](#)).
- (f) Reinstall the service plug grip (see page [HB-154](#)).

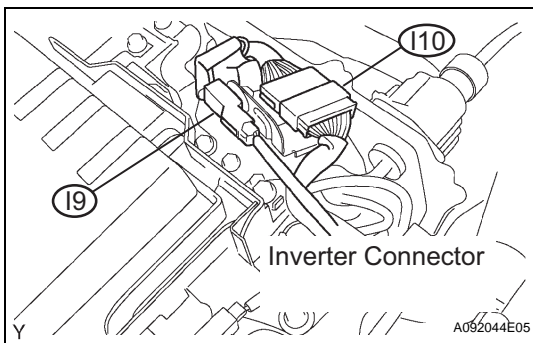

NG **CONNECT SECURELY**

OK

11 CONFIRM INFORMATION (EXCLUSIVE INFO 4)

- (a) Connect the intelligent tester to the DLC3.
- (b) Turn the power switch ON (IG).
 HINT:
 DTCs for the interlock switch system are output when turning the power switch ON (IG) with both service plug grip and inverter cover removed.
- (c) Turn the intelligent tester ON.
- (d) Enter the following menus: DIAGNOSIS / OBD/MOBD / HV ECU / DTC INFO / CURRENT CODES.
- (e) Select DTC P0A7A to display its freeze frame data.
- (f) Select the item that has INF code 322 from among INFORMATION 1 to 5, and press ENTER.
- (g) Read EXCLUSIVE INFO 4.

Result:

Displayed in Exclusive Information 4	Proceed to
-127 to -120, -95 to -88, -63 to -56, -31 to -24, 1 to 8, 33 to 40, 65 to 72, 97 to 104	A
-119 to -112, -87 to -80, -55 to -48, -23 to -16, 9 to 16, 41 to 48, 73 to 80, 105 to 112	B
-111 to -104, -79 to -72, -47 to -40, -15 to -8, 17 to 24, 49 to 56, 81 to 88, 113 to 120	C
-103 to -96, -71 to -64, -39 to -32, -7 to 0, 25 to 32, 57 to 64, 89 to 96, 121 to 127	D

- B** REPLACE HYBRID VEHICLE CONTROL ECU
- C** REPLACE INVERTER WITH CONVERTER ASSEMBLY
- D** REPLACE HYBRID VEHICLE TRANSAXLE ASSEMBLY

A

12 INSPECT HYBRID VEHICLE GENERATOR ASSEMBLY

CAUTION:

Wear insulated gloves before performing the following operation.

- (a) Turn the power switch OFF.
- (b) Remove the service plug grip (see page [HB-154](#)).

NOTICE:

Turning the power switch ON (READY) with the service plug grip removed could cause malfunction. Therefore, never turn the power switch ON (READY) in this state.

- (c) Remove the inverter cover (see page [HV-531](#)).
- (d) Disconnect the three-phase alternating current cable for the hybrid vehicle generator from the inverter.
- (e) Using a milliohm meter, measure the resistance between the three-phase alternating current cable terminals of the hybrid vehicle generator.

NOTICE:

If the generator temperature is too high, the resistance varies considerably, which hinders determining malfunction. Therefore, measure the resistance at a minimum 8 hours after the vehicle has been stopped.

Standard resistance

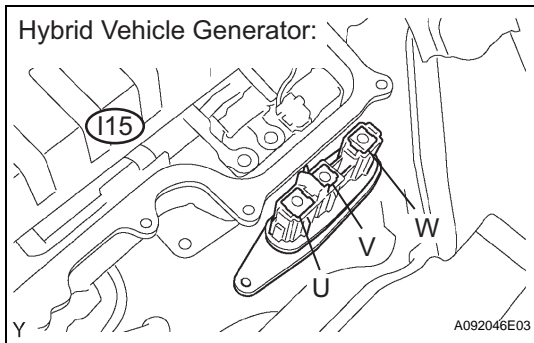

Tester Connection	Specified Condition*
U (I15-1) - V (I15-2)	Below 109 mΩ at 20°C
V (I15-2) - W (I15-3)	Below 109 mΩ at 20°C
W (I15-3) - U (I15-1)	Below 109 mΩ at 20°C

*: Apply the formula given below to correct the resistance.

$$R_{20} = R_t / \{1 + 0.00393 \times (T - 20)\}$$

R₂₀: Resistance converted to 20°C (mΩ)

R_t: Resistance between measured lines (mΩ)

T: Ambient air temperature during measurement (°C)

- (f) Calculate the difference between the maximum and minimum resistance between terminals U - V, V - W, and W - U.

Standard resistance:

Below 2 mΩ

- (g) Using a megohmmeter, measure the insulation resistance between the three-phase alternating current cable terminals of the hybrid vehicle generator and the body ground.

Standard resistance

Tester Connection	Specified Condition
U (I15-1) - Body ground	10 MΩ or higher
V (I15-2) - Body ground	10 MΩ or higher
W (I15-3) - Body ground	10 MΩ or higher

- (h) Reconnect the three-phase alternating current cable for the hybrid vehicle generator.

NG → **REPLACE HYBRID VEHICLE GENERATOR ASSEMBLY**

OK

13 PERFORM ACTIVE TEST BY INTELLIGENT TESTER (INVERTER STOP)

CAUTION:

Wear insulated gloves before performing the following operation.

- (a) Check that the service plug grip and inverter cover have been removed.
- (b) Connect the intelligent tester to the DLC3.
- (c) Turn the power switch ON (IG).

HINT:

DTCs for the interlock switch system are output when turning the power switch ON (IG) with both service plug grip and inverter cover removed.

- (d) Turn the intelligent tester ON.
- (e) Enter the following menus: DIAGNOSIS / OBD/MOBD / HV ECU / ACTIVE TEST.
- (f) Measure the voltage between the terminals of the inverter connector while effecting INVERTER STOP.

Standard voltage

Tester Connection	Specified Condition
GUU (I10-4) - GINV (I10-16)	12 to 16 V
GVU (I10-5) - GINV (I10-16)	12 to 16 V
GWU (I10-6) - GINV (I10-16)	12 to 16 V

- (g) Turn the power switch OFF.

NG → **Go to step 14**

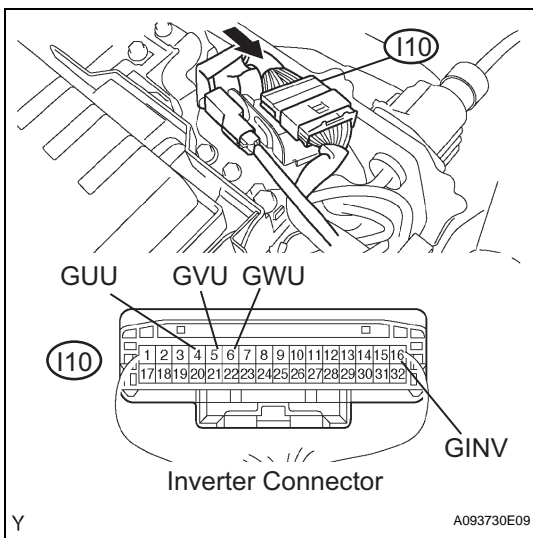

Y

A093730E09

HV

OK

REPLACE INVERTER WITH CONVERTER ASSEMBLY

14 PERFORM ACTIVE TEST BY INTELLIGENT TESTER (INVERTER STOP)

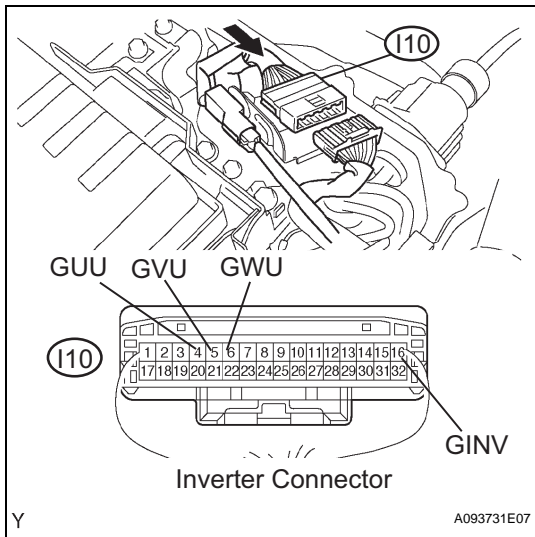

CAUTION:

Wear insulated gloves before performing the following operation.

- (a) Check that the service plug grip and inverter cover have been removed.
- (b) Disconnect the I10 inverter connector.
- (c) Connect the intelligent tester to the DLC3.
- (d) Turn the power switch ON (IG).

HINT:

DTCs for the interlock switch system are output when turning the power switch ON (IG) with both service plug grip and inverter cover removed.

- (e) Turn the intelligent tester ON.
- (f) Enter the following menus: DIAGNOSIS / OBD/MOBD / HV ECU / ACTIVE TEST.
- (g) Measure the voltage between the terminals of the inverter connector while effecting INVERTER STOP.

Standard voltage

Tester Connection	Specified Condition
GUU (I10-4) - GINV (I10-16)	14 to 16 V
GVU (I10-5) - GINV (I10-16)	14 to 16 V
GWU (I10-6) - GINV (I10-16)	14 to 16 V

- (h) Turn the power switch OFF.
- (i) Reconnect the inverter connector.
- (j) Reinstall the inverter cover (see page [HV-538](#)).
- (k) Reinstall the service plug grip (see page [HB-154](#)).

NG

REPLACE INVERTER WITH CONVERTER ASSEMBLY

OK

REPLACE HYBRID VEHICLE CONTROL ECU

HV

DTC	P0A7A-324	Generator Inverter Performance
------------	------------------	---------------------------------------

DESCRIPTION

See the description of the inverter (see page [HV-220](#)).

If the generator inverter has a circuit malfunction, internal short, or overheats, the inverter transmits that information to the GFIV terminal of HV control ECU via the generator inverter fail signal line.

DTC No.	INF Code	DTC Detection Condition	Trouble Area
P0A7A	324	Generator inverter fail (GFIV) signal detection (circuit malfunction)	<ul style="list-style-type: none"> • Wire harness or connector • Inverter with converter assembly

MONITOR DESCRIPTION

If the generator inverter detects a circuit malfunction, it transmits an inverter fail signal to the HV control ECU. Upon receiving this signal, the HV control ECU illuminates the MIL and sets a DTC.

MONITOR STRATEGY

Related DTCs	P0A7A (INF 324): Generator inverter / GFIV detection circuit malfunction
Required sensor / components	Generator inverter
Frequency of operation	Continuous
Duration	TOYOTA's intellectual property
MIL operation	Immediately
Sequence of operation	None

TYPICAL ENABLING CONDITIONS

The monitor will run whenever the following DTCs are not present	TOYOTA's intellectual property
No other condition	-

HV

TYPICAL MALFUNCTION THRESHOLDS

Generator inverter	Circuit malfunction
--------------------	---------------------

COMPONENT OPERATING RANGE

Generator inverter	DTC P0A7A (INF 324) is not detected
--------------------	-------------------------------------

WIRING DIAGRAM

Refer to DTC P0A78 (INF 282) (see page [HV-244](#)).

INSPECTION PROCEDURE

CAUTION:

- Before inspecting the high-voltage system, take safety precautions to prevent electrical shocks, such as wearing insulated gloves and removing the service plug grip. After removing the service plug grip, put it in your pocket to prevent other technicians from reconnecting it while you are servicing the high-voltage system.
- After disconnecting the service plug grip, wait for at least 5 minutes before touching any of the high-voltage connectors or terminals.

HINT:

At least 5 minutes are required to discharge the high-voltage condenser inside the inverter.

1 READ OUTPUT DTC (HV ECU)

- (a) Connect the intelligent tester to the DLC3.
- (b) Turn the power switch ON (IG).
- (c) Turn the intelligent tester ON.
- (d) Enter the following menus: DIAGNOSIS / OBD/MOBD / HV ECU / DTC INFO / CURRENT CODES.
- (e) Read DTCs.

Result:

DTC listed in the table below is output

DTC No.	INF Code	Detection Item	See Page
P0A7A	321 or 323	Generator Inverter Performance	HV-288

YES → **GO TO THE PAGE NUMBER SHOWN IN THE TABLE ABOVE**

NO

2 CHECK CONNECTION CONDITION OF INVERTER CONNECTOR (LOOSENESS AND POOR CONTACT)

CAUTION:

Wear insulated gloves before performing the following operation.

- (a) Turn the power switch OFF.
- (b) Remove the service plug grip (see page [HB-154](#)).

NOTICE:

Turning the power switch ON (READY) with the service plug grip removed could cause malfunction. Therefore, never turn the power switch ON (READY) in this state.

- (c) Remove the inverter cover (see page [HV-531](#)).
- (d) Check the connection condition of the I9 and I10 inverter connectors.

OK :

Connectors have been connected securely and there is no poor connection.

- (e) Reinstall the inverter cover (see page [HV-538](#)).
- (f) Reinstall the service plug grip (see page [HB-154](#)).

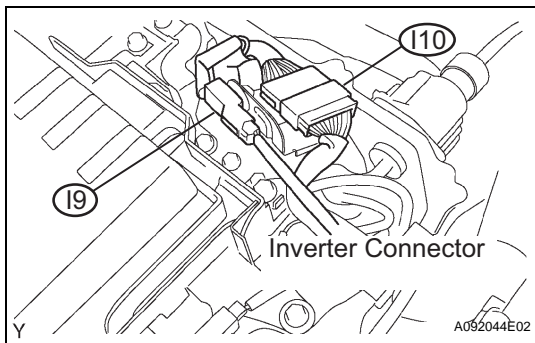

NG → **CONNECT SECURELY**

OK

3 READ OUTPUT DTC (HV ECU)

- (a) Connect the intelligent tester to the DLC3.
- (b) Turn the power switch ON (IG).

HV

HINT:

DTCs for the interlock switch system are output when turning the power switch ON (IG) with both service plug grip and inverter cover removed.

- (c) Turn the intelligent tester ON.
- (d) Enter the following menus: DIAGNOSIS / OBD/MOBD / HV ECU / DTC INFO / CURRENT CODES.
- (e) Read DTCs.

Result:

DTCs P0A78 (INF 282, 286) and P0A7A (INF 324) (inverter circuit malfunction) are output

NO → **REPLACE INVERTER WITH CONVERTER ASSEMBLY**

YES

4 INSPECT INVERTER WITH CONVERTER ASSEMBLY (IGCT VOLTAGE)

CAUTION:

Wear insulated gloves before performing the following operation.

- (a) Turn the power switch OFF.
- (b) Remove the service plug grip (see page [HB-154](#)).

NOTICE:

Turning the power switch ON (READY) with the service plug grip removed could cause malfunction. Therefore, never turn the power switch ON (READY) in this state.

- (c) Remove the inverter cover (see page [HV-531](#)).
- (d) Turn the power switch ON (IG).

HINT:

DTCs for the interlock switch system are output when turning the power switch ON (IG) with both service plug grip and inverter cover removed.

- (e) Measure the voltage between the terminals of the inverter connector.

Standard voltage

Tester Connection	Specified Condition
IGCT (I9-1) - GND1 (I9-2)	8 V or more

- (f) Turn the power switch OFF.
- (g) Reinstall the inverter cover (see page [HV-538](#)).
- (h) Reinstall the service plug grip (see page [HB-154](#)).

NG → **REPAIR OR REPLACE HARNESS OR CONNECTOR**

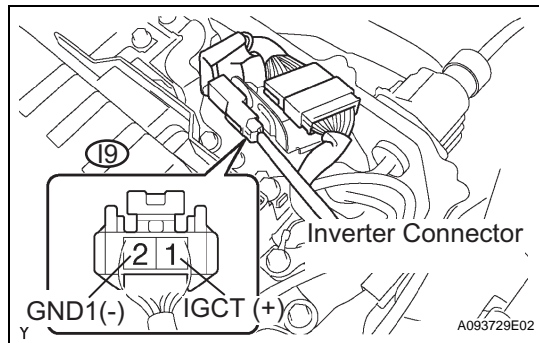

OK

REPLACE INVERTER WITH CONVERTER ASSEMBLY

DTC	P0A7A-325	Generator Inverter Performance
DTC	P0A7A-517	Generator Inverter Performance
DTC	P0A7A-518	Generator Inverter Performance

DESCRIPTION

See the description of the inverter (see page [HV-220](#)).

If the generator inverter has a circuit malfunction, internal short, or overheats, the inverter transmits that information to the GFIV terminal of HV control ECU via the generator inverter fail signal line.

DTC No.	INF Code	DTC Detection Condition	Trouble Area
P0A7A	325	Generator inverter fail (GFIV) signal detection (over current by inverter assembly malfunction)	<ul style="list-style-type: none"> Wire harness or connector HV transaxle assembly Hybrid vehicle generator HV control ECU Inverter with converter assembly
P0A7A	517	Generator inverter fail (GFIV) signal detection (over current by HV control ECU malfunction)	<ul style="list-style-type: none"> HV transaxle assembly Hybrid vehicle generator HV control ECU Inverter with converter assembly Wire harness or connector
P0A7A	518	Generator inverter fail (GFIV) signal detection (over current by HV transaxle assembly malfunction)	<ul style="list-style-type: none"> Wire harness or connector HV transaxle assembly Hybrid vehicle generator HV control ECU Inverter with converter assembly

HV

MONITOR DESCRIPTION

If over-amperage flows through the generator inverter due to an internal short, the generator inverter transmits an inverter fail signal to the HV control ECU. Upon receiving this signal, the HV control ECU illuminates the MIL and sets a DTC.

MONITOR STRATEGY

Related DTCs	P0A7A (INF 325 / 517 / 518): Generator inverter / GFIV detection over current
Required sensor / components	Generator inverter
Frequency of operation	Continuous
Duration	TOYOTA's intellectual property
MIL operation	Immediately
Sequence of operation	None

TYPICAL ENABLING CONDITIONS

The monitor will run whenever the following DTCs are not present	TOYOTA's intellectual property
No other condition	-

TYPICAL MALFUNCTION THRESHOLDS

Generator inverter	Over current (internal short)
--------------------	-------------------------------

COMPONENT OPERATING RANGE

Generator inverter	DTC P0A7A (INF 325 / 517 / 518) is not detected
--------------------	---

WIRING DIAGRAM

Refer to DTC P0A78 (INF 279) (see page [HV-235](#)).

INSPECTION PROCEDURE

CAUTION:

- Before inspecting the high-voltage system, take safety precautions to prevent electrical shocks, such as wearing insulated gloves and removing the service plug grip. After removing the service plug grip, put it in your pocket to prevent other technicians from reconnecting it while you are servicing the high-voltage system.
- After disconnecting the service plug grip, wait for at least 5 minutes before touching any of the high-voltage connectors or terminals.

HINT:

At least 5 minutes are required to discharge the high-voltage condenser inside the inverter.

1	READ OUTPUT DTC (HV ECU)
----------	---------------------------------

- Connect the intelligent tester to the DLC3.
- Turn the power switch ON (IG).
- Turn the intelligent tester ON.
- Enter the following menus: DIAGNOSIS / OBD/MOBD / HV ECU / DTC INFO / CURRENT CODES.
- Read DTCs.

Result:

DTCs listed in the table below are output

DTC No.	Relevant Diagnosis
P0A1D	Hybrid Powertrain Control Module
P0A2B, P0A2C or P0A2D	Drive Motor "A" Temperature Sensor Circuit System
P0A37, P0A38 or P0A39	Generator Temperature Sensor Circuit System
P0A3F, P0A40 or P0A4	Drive Motor "A" Position Sensor Circuit System
P0A4B, P0A4C or P0A4D	Generator Position Sensor Circuit System
P0A60 or P0A63	Drive Motor "A" Current Sensor Circuit System
P0A72 or P0A75	Generator Current Sensor Circuit System
P0A78	Drive Motor "A" Inverter Performance
P0A7A	Generator Inverter Performance
P0A90	Drive Motor "A" Performance
P0A92	Hybrid Generator Performance
P0A93	Inverter Cooling System Malfunction
P0A94	DC / DC Converter Malfunction
P0AA1, P0AA4, P0AE0, P0AE6, P0AE7, P0ADB or P0ADF	System Main Relay Circuit System
P0AA6, P3004	High Voltage System
P0AEE	Motor Inverter Temperature Sensor Malfunction
P3000	HV Battery System Malfunction
P3110	Integration Relay Malfunction

DTC No.	Relevant Diagnosis
P3221	Generator Inverter Temperature Sensor Circuit System
P3226	DC / DC Boost Converter Temperature Sensor Circuit System

YES → **GO TO DTC CHART. FIND PAGE NUMBER TO PROCEED TO DIAGNOSTIC TROUBLESHOOTING FLOWCHART**

NO

2 CHECK CONNECTION CONDITION OF HYBRID VEHICLE CONTROL ECU CONNECTOR (LOOSENESS AND POOR CONTACT)

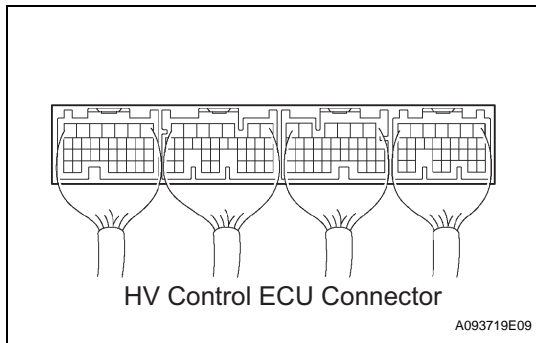

(a) Check the connection condition of all the connectors at the HV control ECU.

OK:

Connectors have been connected securely and there is no poor connection.

NG → **CONNECT SECURELY**

OK

3 CHECK CONNECTION CONDITION OF INVERTER CONNECTOR (LOOSENESS AND POOR CONTACT)

HV

CAUTION:

Wear insulated gloves before performing the following operation.

- (a) Turn the power switch OFF.
- (b) Remove the service plug grip (see page [HB-154](#)).

NOTICE:

Turning the power switch ON (READY) with the service plug grip removed could cause malfunction. Therefore, never turn the power switch ON (READY) in this state.

- (c) Remove the inverter cover (see page [HV-531](#)).
- (d) Check the connection condition of the I9 and I10 inverter connectors.

OK:

Connectors have been connected securely and there is no poor connection.

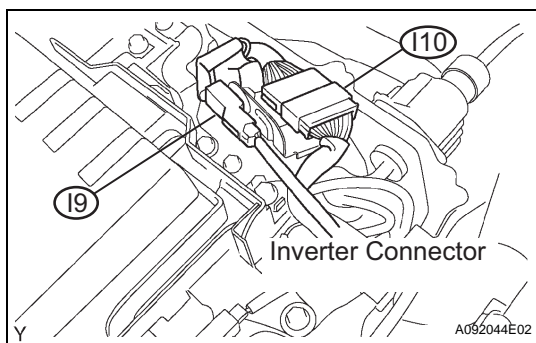

NG → **CONNECT SECURELY**

OK

4 CHECK HYBRID VEHICLE GENERATOR ASSEMBLY

CAUTION:

Wear insulated gloves before performing the following operation.

- (a) Check that the service plug grip and inverter cover have been removed.
- (b) Check if the three-phase alternating current cable installation bolts on the hybrid vehicle generator are tightened to the specified torque.

Torque: 8.0 N*m (82 kgf*cm, 71 in.*lbf)

- (c) Reinstall the inverter cover (see page HV-538).
- (d) Reinstall the service plug grip (see page HB-154).

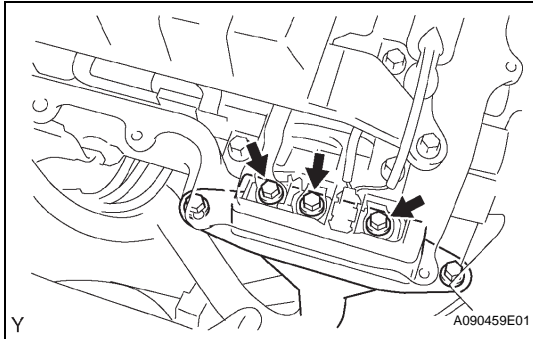

NG **TIGHTEN THEM TO SPECIFIED TORQUE**

OK

5 CONFIRM INFORMATION (EXCLUSIVE INFO 4)

- (a) Connect the intelligent tester to the DLC3.
- (b) Turn the power switch ON (IG).
HINT:
DTCs for the interlock switch system are output when turning the power switch ON (IG) with both service plug grip and inverter cover removed.
- (c) Turn the intelligent tester ON.
- (d) Enter the following menus: DIAGNOSIS / OBD/MOBD / HV ECU / DTC INFO / CURRENT CODES.
- (e) Select DTC P0A7A to display its freeze frame data.
- (f) Select the item that has INF code 325, 517, or 518 from among INFORMATION 1 to 5, and press ENTER.
- (g) Read EXCLUSIVE INFO 4.

Result:

Displayed in Exclusive Information 4	Proceed to
-127 to -120, -95 to -88, -63 to -56, -31 to -24, 1 to 8, 33 to 40, 65 to 72, 97 to 104	A
-119 to -112, -87 to -80, -55 to -48, -23 to -16, 9 to 16, 41 to 48, 73 to 80, 105 to 112	B
-111 to -104, -79 to -72, -47 to -40, -15 to -8, 17 to 24, 49 to 56, 81 to 88, 113 to 120	C
-103 to -96, -71 to -64, -39 to -32, -7 to 0, 25 to 32, 57 to 64, 89 to 96, 121 to 127	D

B **REPLACE HYBRID VEHICLE CONTROL ECU**

C **REPLACE INVERTER WITH CONVERTER ASSEMBLY**

D REPLACE HYBRID VEHICLE TRANSAXLE ASSEMBLY

A

6 INSPECT HYBRID VEHICLE GENERATOR ASSEMBLY

CAUTION:

Wear insulated gloves before performing the following operation.

- (a) Turn the power switch OFF.
- (b) Remove the service plug grip (see page [HB-154](#)).

NOTICE:

Turning the power switch ON (READY) with the service plug grip removed could cause malfunction. Therefore, never turn the power switch ON (READY) in this state.

- (c) Remove the inverter cover (see page [HV-531](#)).
- (d) Disconnect the three-phase alternating current cable for the hybrid vehicle generator from the inverter.
- (e) Using a milliohm meter, measure the resistance between the three-phase alternating current cable terminals of the hybrid vehicle generator.

NOTICE:

If the generator temperature is too high, the resistance varies considerably, which hinders determining malfunction. Therefore, measure the resistance at a minimum 8 hours after the vehicle has been stopped.

Standard resistance

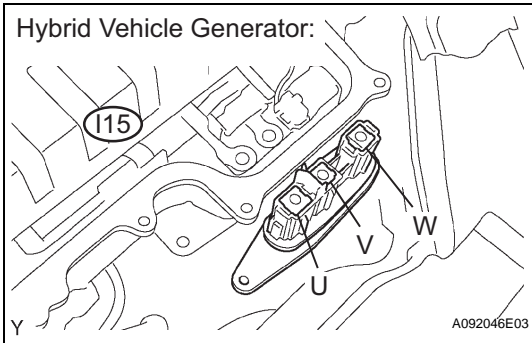

Tester Connection	Specified Condition*
U (I15-1) - V (I15-2)	Below 109 mΩ at 20°C
V (I15-2) - W (I15-3)	Below 109 mΩ at 20°C
W (I15-3) - U (I15-1)	Below 109 mΩ at 20°C

*: Apply the formula given below to correct the resistance.

$$R_{20} = R_t / \{1 + 0.00393 \times (T - 20)\}$$

R₂₀: Resistance converted to 20°C (mΩ)

R_t: Resistance between measured lines (mΩ)

T: Ambient air temperature during measurement (°C)

- (f) Calculate the difference between the maximum and minimum resistance between terminals U - V, V - W, and W - U.

Standard resistance:

Below 2 mΩ

- (g) Using a megohmmeter, measure the insulation resistance between the three-phase alternating current cable terminals of the hybrid vehicle generator and the body ground.

Standard resistance

Tester Connection	Specified Condition
U (I15-1) - Body ground	10 MΩ or higher

Tester Connection	Specified Condition
V (I15-2) - Body ground	10 MΩ or higher
W (I15-3) - Body ground	10 MΩ or higher

(h) Reconnect the three-phase alternating current cable for the hybrid vehicle generator.

NG **REPLACE HYBRID VEHICLE GENERATOR ASSEMBLY**

OK

7 PERFORM ACTIVE TEST BY INTELLIGENT TESTER (INVERTER STOP)

CAUTION:

Wear insulated gloves before performing the following operation.

- (a) Check that the service plug grip and inverter cover have been removed.
- (b) Connect the intelligent tester to the DLC3.
- (c) Turn the power switch ON (IG).

HINT:

DTCs for the interlock switch system are output when turning the power switch ON (IG) with both service plug grip and inverter cover removed.

- (d) Turn the intelligent tester ON.
- (e) Enter the following menus: DIAGNOSIS / OBD/MOBD / HV ECU / ACTIVE TEST.
- (f) Measure the voltage between the terminals of the inverter connector while effecting INVERTER STOP.

Standard voltage

Tester Connection	Specified Condition
GUU (I10-4) - GINV (I10-16)	12 to 16 V
GVU (I10-5) - GINV (I10-16)	12 to 16 V
GWU (I10-6) - GINV (I10-16)	12 to 16 V

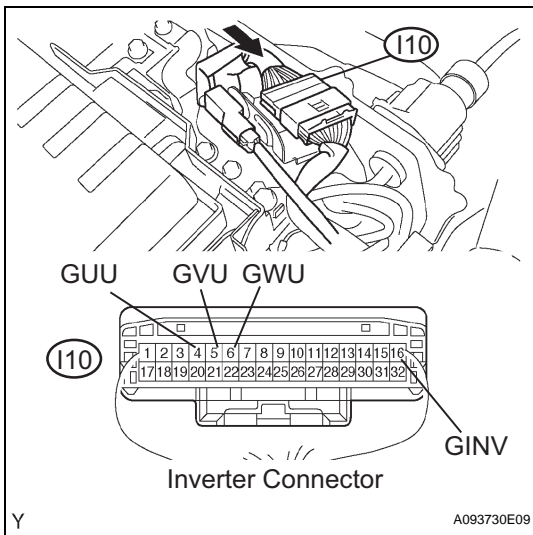

- (g) Turn the power switch OFF.

NG **Go to step 8**

OK

REPLACE INVERTER WITH CONVERTER ASSEMBLY

HV

8 PERFORM ACTIVE TEST BY INTELLIGENT TESTER (INVERTER STOP)

CAUTION:

Wear insulated gloves before performing the following operation.

- (a) Check that the service plug grip and inverter cover have been removed.
- (b) Disconnect the I10 inverter connector.
- (c) Connect the intelligent tester to the DLC3.
- (d) Turn the power switch ON (IG).

HINT:

DTCs for the interlock switch system are output when turning the power switch ON (IG) with both service plug grip and inverter cover removed.

- (e) Turn the intelligent tester ON.
- (f) Enter the following menus: DIAGNOSIS / OBD/MOBD / HV ECU / ACTIVE TEST.
- (g) Measure the voltage between the terminals of the inverter connector while effecting INVERTER STOP.

Standard voltage

Tester Connection	Specified Condition
GUU (I10-4) - GINV (I10-16)	14 to 16 V
GVU (I10-5) - GINV (I10-16)	14 to 16 V
GWU (I10-6) - GINV (I10-16)	14 to 16 V

- (h) Turn the power switch OFF.
- (i) Reconnect the inverter connector.
- (j) Reinstall the inverter cover (see page [HV-538](#)).
- (k) Reinstall the service plug grip (see page [HB-154](#)).

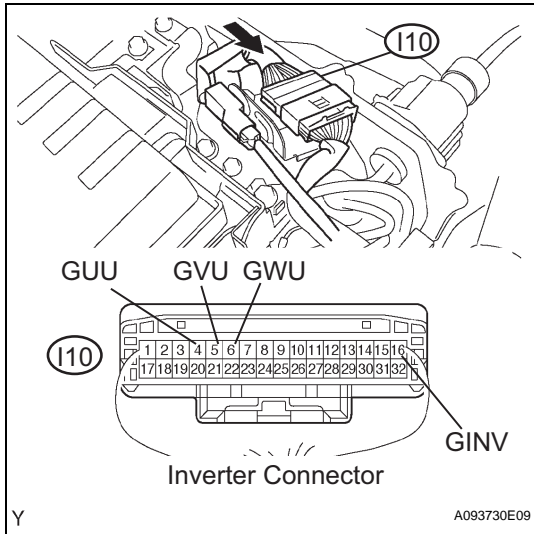

NG **REPLACE INVERTER WITH CONVERTER ASSEMBLY**

OK

REPLACE HYBRID VEHICLE CONTROL ECU

DTC	P0A7A-342	Generator Inverter Performance
DTC	P0A7A-343	Generator Inverter Performance
DTC	P0A7A-519	Generator Inverter Performance

DESCRIPTION

See the description of the inverter (see page [HV-220](#)).

Upon receiving a generator gate shutdown signal from the HV control ECU, the inverter forcefully stops the operation of the MG1 by turning OFF the power transistors that are actuating the MG1.

The HV control ECU monitors the generator gate shutdown signal line and detects a malfunction.

DTC No.	INF Code	DTC Detection Condition	Trouble Area
P0A7A	342	Open or +B short in generator gate shutdown (GSDN) signal circuit	<ul style="list-style-type: none"> Wire harness or connector Inverter with converter assembly
P0A7A	343	GND short in generator gate shutdown (GSDN) signal circuit	<ul style="list-style-type: none"> Wire harness or connector Inverter with converter assembly
P0A7A	519	Open in generator gate shutdown (GSDN) signal circuit	<ul style="list-style-type: none"> Wire harness or connector Inverter with converter assembly

MONITOR DESCRIPTION

The HV control ECU monitors the generator gate shutdown (GSDN) signal line. If the HV control ECU detects an open or short malfunction of the GSDN signal circuit, the HV control ECU illuminates the MIL and sets a DTC.

HV

MONITOR STRATEGY

Related DTCs	P0A7A (INF 342 / 343 / 519): Generator inverter / Generator gate shutdown signal malfunction
Required sensor / components	Generator inverter
Frequency of operation	Continuous
Duration	TOYOTA's intellectual property
MIL operation	1 driving cycle
Sequence of operation	None

TYPICAL ENABLING CONDITIONS

The monitor will run whenever the following DTCs are not present	TOYOTA's intellectual property
Other conditions belong to TOYOTA's intellectual property	-

TYPICAL MALFUNCTION THRESHOLDS

Generator gate shutdown signal circuit	Open or short
--	---------------

COMPONENT OPERATING RANGE

Generator inverter

DTC P0A7A (INF 342 / 343 / 519) is not detected

WIRING DIAGRAM

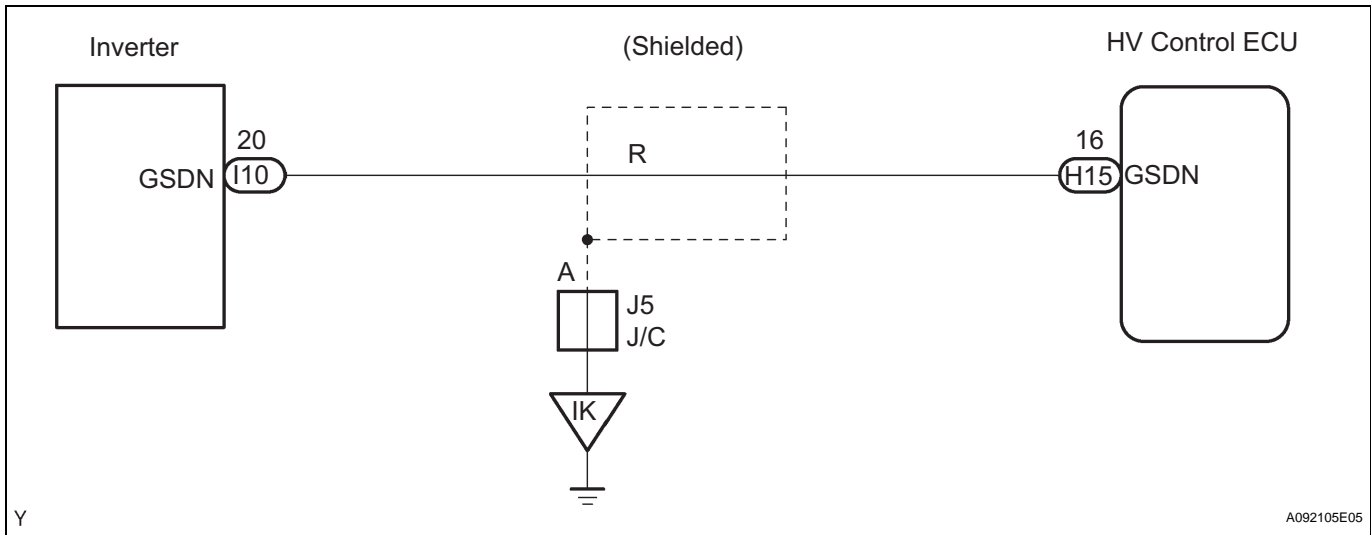

INSPECTION PROCEDURE

CAUTION:

- Before inspecting the high-voltage system, take safety precautions to prevent electrical shocks, such as wearing insulated gloves and removing the service plug grip. After removing the service plug grip, put it in your pocket to prevent other technicians from reconnecting it while you are servicing the high-voltage system.
- After disconnecting the service plug grip, wait for at least 5 minutes before touching any of the high-voltage connectors or terminals.

HV

HINT:

At least 5 minutes are required to discharge the high-voltage condenser inside the inverter.

1

CHECK HARNESS AND CONNECTOR (HYBRID VEHICLE CONTROL ECU - INVERTER)

CAUTION:

Wear insulated gloves before performing the following operation.

- Turn the power switch OFF.
- Remove the service plug grip (see page [HB-154](#)).

NOTICE:

Turning the power switch ON (READY) with the service plug grip removed could cause malfunction. Therefore, never turn the power switch ON (READY) in this state.

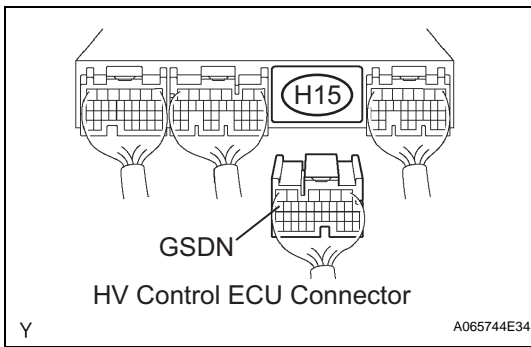

- (c) Disconnect the H15 HV control ECU connector.
- (d) Remove the inverter cover (see page HV-531).

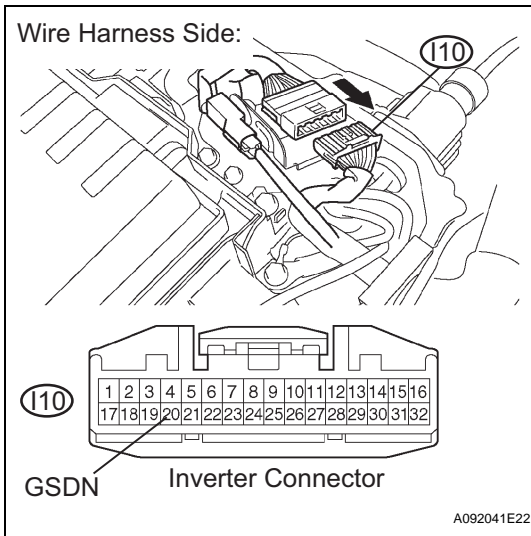

- (e) Disconnect the I10 inverter connector.
- (f) Turn the power switch ON (IG).
HINT:
DTCs for the interlock switch system are output when turning the power switch ON (IG) with both service plug grip and inverter cover removed.
- (g) Measure the voltage between the terminal of the HV control ECU connector and body ground.

Standard voltage

Tester Connection	Specified Condition
GSDN (H15-16) - Body ground	Below 1 V

- (h) Turn the power switch OFF.
- (i) Measure the resistance between the wire harness side connectors.

Standard resistance (Check for open)

Tester Connection	Specified Condition
GSDN (H15-16) - GSDN (I10-20)	Below 1 Ω

Standard resistance (Check for short)

Tester Connection	Specified Condition
GSDN (H15-16) or GSDN (I10-20) - Body ground	10 kΩ or higher

- (j) Reconnect the inverter connector.
- (k) Reconnect the HV control ECU connector.
- (l) Reinstall the inverter cover (see page HV-538).
- (m) Reinstall the service plug grip (see page HB-154).

NG → **REPAIR OR REPLACE HARNESS OR CONNECTOR**

OK

REPLACE INVERTER WITH CONVERTER ASSEMBLY

HV

DTC	P0A7A-344	Generator Inverter Performance
------------	------------------	---------------------------------------

DESCRIPTION

See the description of the inverter (see page [HV-220](#)).

The HV control ECU controls MG1 torque in accordance with the driving condition.

DTC No.	INF Code	DTC Detection Condition	Trouble Area
P0A7A	344	Failure in monitoring MG1 torque performance	<ul style="list-style-type: none"> Hybrid vehicle generator Inverter with converter assembly

MONITOR DESCRIPTION

If the difference between the requested MG1 torque and the actual MG1 torque exceeds a predetermined value, the HV control ECU determines that there is a malfunction in the execution or monitoring of the MG1 torque. Then, the HV control ECU illuminates the MIL and sets a DTC.

MONITOR STRATEGY

Related DTCs	P0A7A (INF 344): Generator inverter / Discrepancy between generator monitored torque and commanded torque
Required sensor / components	Generator inverter
Frequency of operation	Continuous
Duration	TOYOTA's intellectual property
MIL operation	Immediately
Sequence of operation	None

TYPICAL ENABLING CONDITIONS

The monitor will run whenever the following DTCs are not present	TOYOTA's intellectual property
No other condition	-

TYPICAL MALFUNCTION THRESHOLDS

Difference between demanded and actual MG1 torque	Exceeds the standard level
---	----------------------------

COMPONENT OPERATING RANGE

Generator inverter	DTC P0A7A (INF 344) is not detected
--------------------	-------------------------------------

INSPECTION PROCEDURE

CAUTION:

- Before inspecting the high-voltage system, take safety precautions to prevent electrical shocks, such as wearing insulated gloves and removing the service plug grip. After removing the service plug grip, put it in your pocket to prevent other technicians from reconnecting it while you are servicing the high-voltage system.
- After disconnecting the service plug grip, wait for at least 5 minutes before touching any of the high-voltage connectors or terminals.

HINT:

At least 5 minutes are required to discharge the high-voltage condenser inside the inverter.

1 READ OUTPUT DTC (HV ECU)

- (a) Connect the intelligent tester to the DLC3.
- (b) Turn the power switch ON (IG).
- (c) Turn the intelligent tester ON.
- (d) Enter the following menus: DIAGNOSIS / OBD/MOBD / HV ECU / DTC INFO / CURRENT CODES.
- (e) Read DTCs.

Result:

DTC P0A7A (INF 344) and other DTCs are output

HINT:

If any other codes besides P0A7A (INF 344) are output, perform troubleshooting for those DTCs first.

YES → **GO TO RELEVANT DTC CHART**

NO

2 INSPECT HYBRID VEHICLE GENERATOR ASSEMBLY

CAUTION:

Wear insulated gloves before performing the following operation.

- (a) Turn the power switch OFF.
- (b) Remove the service plug grip (see page [HB-154](#)).

NOTICE:

Turning the power switch ON (READY) with the service plug grip removed could cause malfunction. Therefore, never turn the power switch ON (READY) in this state.

- (c) Remove the inverter cover (see page [HV-531](#)).
- (d) Disconnect the three-phase alternating current cable for the hybrid vehicle generator from the inverter.
- (e) Using a milliohm meter, measure the resistance between the three-phase alternating current cable terminals of the hybrid vehicle generator.

NOTICE:

If the generator temperature is too high, the resistance varies considerably, which hinders determining malfunction. Therefore, measure the resistance at a minimum 8 hours after the vehicle has been stopped.

Standard resistance

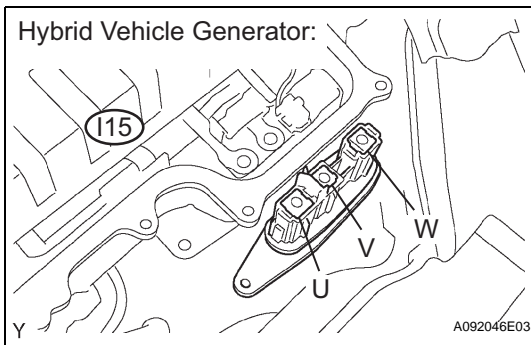

Tester Connection	Specified Condition*
U (I15-1) - V (I15-2)	Below 109 mΩ at 20°C
V (I15-2) - W (I15-3)	Below 109 mΩ at 20°C
W (I15-3) - U (I15-1)	Below 109 mΩ at 20°C

*: Apply the formula given below to correct the resistance.

$$R_{20} = R_t / \{1 + 0.00393 \times (T - 20)\}$$

R₂₀: Resistance converted to 20°C (mΩ)

R_t: Resistance between measured lines (mΩ)

T: Ambient air temperature during measurement (°C)

- (f) Calculate the difference between the maximum and minimum resistance between terminals U - V, V - W, and W - U.

Standard resistance:

Below 2 mΩ

- (g) Using a megohmmeter, measure the insulation resistance between the three-phase alternating current cable terminals of the hybrid vehicle generator and the body ground.

Standard resistance

Tester Connection	Specified Condition
U (I15-1) - Body ground	10 MΩ or higher
V (I15-2) - Body ground	10 MΩ or higher
W (I15-3) - Body ground	10 MΩ or higher

- (h) Reconnect the three-phase alternating current cable for the hybrid vehicle generator.
- (i) Reinstall the inverter cover (see page [HV-538](#)).
- (j) Reinstall the service plug grip (see page [HB-154](#)).

NG
REPLACE HYBRID VEHICLE GENERATOR ASSEMBLY

OK

REPLACE INVERTER WITH CONVERTER ASSEMBLY

DTC	P0A7A-520	Generator Inverter Performance
------------	------------------	---------------------------------------

DESCRIPTION

See the description of the inverter (see page [HV-220](#)).

Upon receiving a generator gate shutdown signal from the HV control ECU, the inverter forcefully stops the operation of the MG1 by turning OFF the power transistors that are actuating the MG1.

The HV control ECU monitors the generator gate shutdown signal and detects a malfunction.

DTC No.	INF Code.	DTC Detection Condition	Trouble Area
P0A7A	520	Generator gate shutdown (GSDN) signal malfunction	<ul style="list-style-type: none"> • Wire harness or connector • HV control ECU

MONITOR DESCRIPTION

The HV control ECU monitors the generator gate shutdown (GSDN) signal. If the HV control ECU detects a fault in the GSDN signal, it illuminates the MIL and sets a DTC.

MONITOR STRATEGY

Related DTCs	P0A7A (INF 520): Generator inverter shutdown signal line malfunction
Required sensor / components	Generator inverter
Frequency of operation	Continuous
Duration	TOYOTA's intellectual property
MIL operation	Immediately
Sequence of operation	None

TYPICAL ENABLING CONDITIONS

The monitor will run whenever the following DTCs are not present	TOYOTA's intellectual property
Other conditions belong to TOYOTA's intellectual property	-

HV

TYPICAL MALFUNCTION THRESHOLDS

Actual status of shutdown command signal and its monitoring result	Inconsistent
--	--------------

COMPONENT OPERATING RANGE

Generator inverter	DTC P0A7A (INF 520) is not detected
--------------------	-------------------------------------

WIRING DIAGRAM

Refer to DTC P0A7A (INF 342) (see page [HV-310](#)).

INSPECTION PROCEDURE

CAUTION:

- Before inspecting the high-voltage system, take safety precautions to prevent electrical shocks, such as wearing insulated gloves and removing the service plug grip. After removing the service plug grip, put it in your pocket to prevent other technicians from reconnecting it while you are servicing the high-voltage system.
- After disconnecting the service plug grip, wait for at least 5 minutes before touching any of the high-voltage connectors or terminals.

HINT:

At least 5 minutes are required to discharge the high-voltage condenser inside the inverter.

1 READ OUTPUT DTC (HV ECU)

- (a) Connect the intelligent tester to the DLC3.
- (b) Turn the power switch ON (IG).
- (c) Turn the intelligent tester ON.
- (d) Enter the following menus: DIAGNOSIS / OBD/MOBD / HV ECU / DTC INFO CURRENT CODES.
- (e) Read DTCs.

Result:

DTC P0A7A (INF 520) and other DTCs are output

HINT:

If any other codes besides P0A7A (INF 520) are output, perform troubleshooting for those DTCs first.

YES

GO TO RELEVANT DTC CHART

NO

2 CHECK HARNESS AND CONNECTOR (HYBRID VEHICLE CONTROL ECU - INVERTER)

CAUTION:

Wear insulated gloves before performing the following operation.

- (a) Turn the power switch OFF.
- (b) Remove the service plug grip (see page [HB-154](#)).

NOTICE:

Turning the power switch ON (READY) with the service plug grip removed could cause malfunction. Therefore, never turn the power switch ON (READY) in this state.

- (c) Disconnect the H15 HV control ECU connector.
- (d) Remove the inverter cover (see page [HV-531](#)).

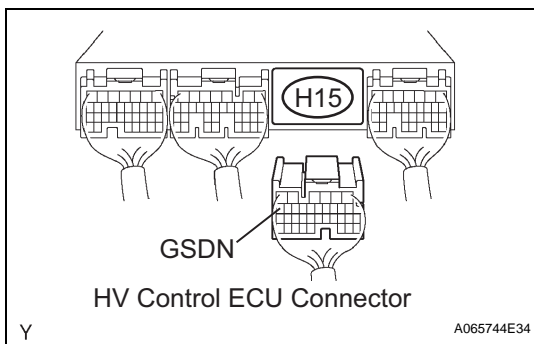

HV

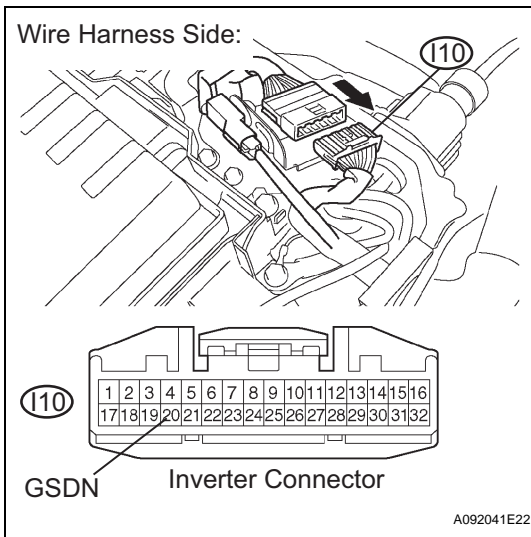

- (e) Disconnect the I10 inverter connector.
- (f) Turn the power switch ON (IG).
HINT:
DTCs for the interlock switch system are output when turning the power switch ON (IG) with both service plug grip and inverter cover removed.
- (g) Measure the voltage between the terminal of the HV control ECU connector and body ground.

Standard voltage

Tester Connection	Specified Condition
GSDN (H15-16) - Body ground	Below 1 V

- (h) Turn the power switch OFF.
- (i) Measure the resistance between the wire harness side connectors.

Standard resistance (Check for open)

Tester Connection	Specified Condition
GSDN (H15-16) - GSDN (I10-20)	Below 1 Ω

Standard resistance (Check for short)

Tester Connection	Specified Condition
GSDN (H15-16) or GSDN (I10-20) - Body ground	10 kΩ or higher

- (j) Reconnect the inverter connector.
- (k) Reconnect the HV control ECU connector.
- (l) Reinstall the inverter cover (see page [HV-538](#)).
- (m) Reinstall the service plug grip (see page [HB-154](#)).

NG	REPAIR OR REPLACE HARNESS OR CONNECTOR
-----------	---

OK

REPLACE HYBRID VEHICLE CONTROL ECU

DTC	P0A7A-522	Generator Inverter Performance
------------	------------------	---------------------------------------

DESCRIPTION

See the description of the inverter (see page [HV-220](#)).

Upon receiving a generator gate shutdown signal from the HV control ECU, the inverter forcefully stops the operation of the MG1 by turning OFF the power transistors that are actuating the MG1.

The HV control ECU monitors the generator inverter gate and detects a malfunction.

DTC No.	INF Code	DTC Detection Condition	Trouble Area
P0A7A	522	Generator inverter gate malfunction	<ul style="list-style-type: none"> • Wire harness or connector • Inverter with converter assembly

MONITOR STRATEGY

Related DTCs	P0A7A (INF 522): Malfunction of Inverter gate shutdown circuit
Required sensors / components	Generator inverter
Frequency of operation	Continuous
Duration	TOYOTA's intellectual property
MIL operation	Immediately
Sequence of operation	None

TYPICAL ENABLING CONDITIONS

The monitor will run whenever the DTCs listed are not present	TOYOTA's intellectual property
Other conditions belong to TOYOTA's intellectual property	-

TYPICAL MALFUNCTION THRESHOLDS

TOYOTA's intellectual property	-
--------------------------------	---

COMPONENT OPERATING RANGE

Generator inverter	DTC P0A7A (INF 522) is not detected
--------------------	-------------------------------------

WIRING DIAGRAM

Refer to DTC P0A7A (INF 342) (see page [HV-310](#)).

INSPECTION PROCEDURE

CAUTION:

- Before inspecting the high-voltage system, take safety precautions to prevent electrical shocks, such as wearing insulated gloves and removing the service plug grip. After removing the service plug grip, put it in your pocket to prevent other technicians from reconnecting it while you are servicing the high-voltage system.
- After disconnecting the service plug grip, wait for at least 5 minutes before touching any of the high-voltage connectors or terminals.

HINT:

At least 5 minutes are required to discharge the high-voltage condenser inside the inverter.

1 CHECK HARNESS AND CONNECTOR (HYBRID VEHICLE CONTROL ECU - INVERTER)

CAUTION:

Wear insulated gloves before performing the following operation.

- (a) Turn the power switch OFF.
- (b) Remove the service plug grip (see page [HB-154](#)).

NOTICE:

Turning the power switch ON (READY) with the service plug grip removed could cause malfunction. Therefore, never turn the power switch ON (READY) in this state.

- (c) Disconnect the H15 HV control ECU connector.
- (d) Remove the inverter cover (see page [HV-531](#)).

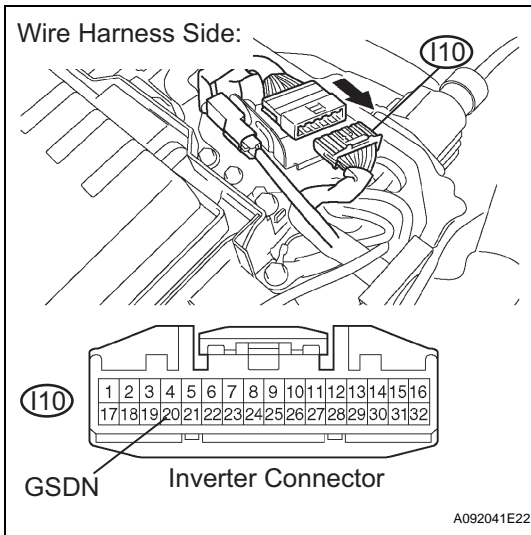
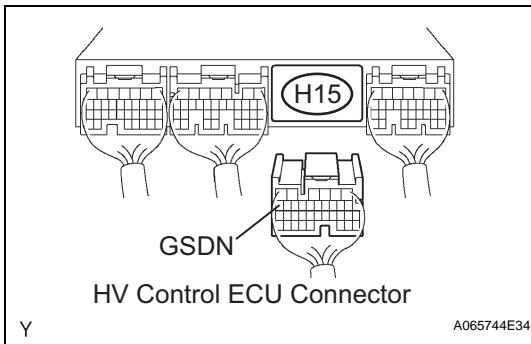

- (e) Disconnect the I10 inverter connector.
- (f) Turn the power switch ON (IG).

HINT:

DTCs for the interlock switch system are output when turning the power switch ON (IG) with both service plug grip and inverter cover removed.

- (g) Measure the voltage between the terminal of the HV control ECU connector and body ground.

Standard voltage

Tester Connection	Specified Condition
GSDN (H15-16) - Body ground	Below 1 V

- (h) Turn the power switch OFF.
- (i) Measure the resistance between the wire harness side connectors.

Standard resistance (Check for open)

Tester Connection	Specified Condition
GSDN (H15-16) - GSDN (I10-20)	Below 1 Ω

Standard resistance (Check for short)

Tester Connection	Specified Condition
GSDN (H15-16) or GSDN (I10-20) - Body ground	10 kΩ or higher

- (j) Reconnect the inverter connector.
- (k) Reconnect the HV control ECU connector.
- (l) Reinstall the inverter cover (see page [HV-538](#)).
- (m) Reinstall the service plug grip (see page [HB-154](#)).

NG REPAIR OR REPLACE HARNESS OR CONNECTOR

HV

OK

REPLACE INVERTER WITH CONVERTER ASSEMBLY

DTC	P0A90-239	Drive Motor "A" Performance
DTC	P0A90-241	Drive Motor "A" Performance
DTC	P0A90-602	Drive Motor "A" Performance

DESCRIPTION

The HV transaxle consists of a planetary gear unit, MG1 and MG2.

A gear unit uses the planetary gear to split engine output in accordance with a driving request during driving the vehicle or charging its internal HV battery.

The MG2 provides assistance to the engine output while increasing the drive force of the vehicle.

Furthermore, the MG2 effects regenerative braking by converting the energy (which is consumed in the form of heat during normal braking) into electrical energy and recovering it into the HV battery. Through regenerative braking, as well as decelerating the vehicle, the MG2 generates high-voltage electrical power which is used for the purpose of charging the HV battery.

The MG1 supplies electrical power, which is used for charging the HV battery or for driving the MG2. It also has a stepless transmission function to control the transaxle by regulating the amount of generation of electrical energy, which effectively varies the MG1 speed. In addition, the MG1 is used as a starter motor to start the engine.

The transmission input damper absorbs the shock that accompanies transmission of the drive force from the engine.

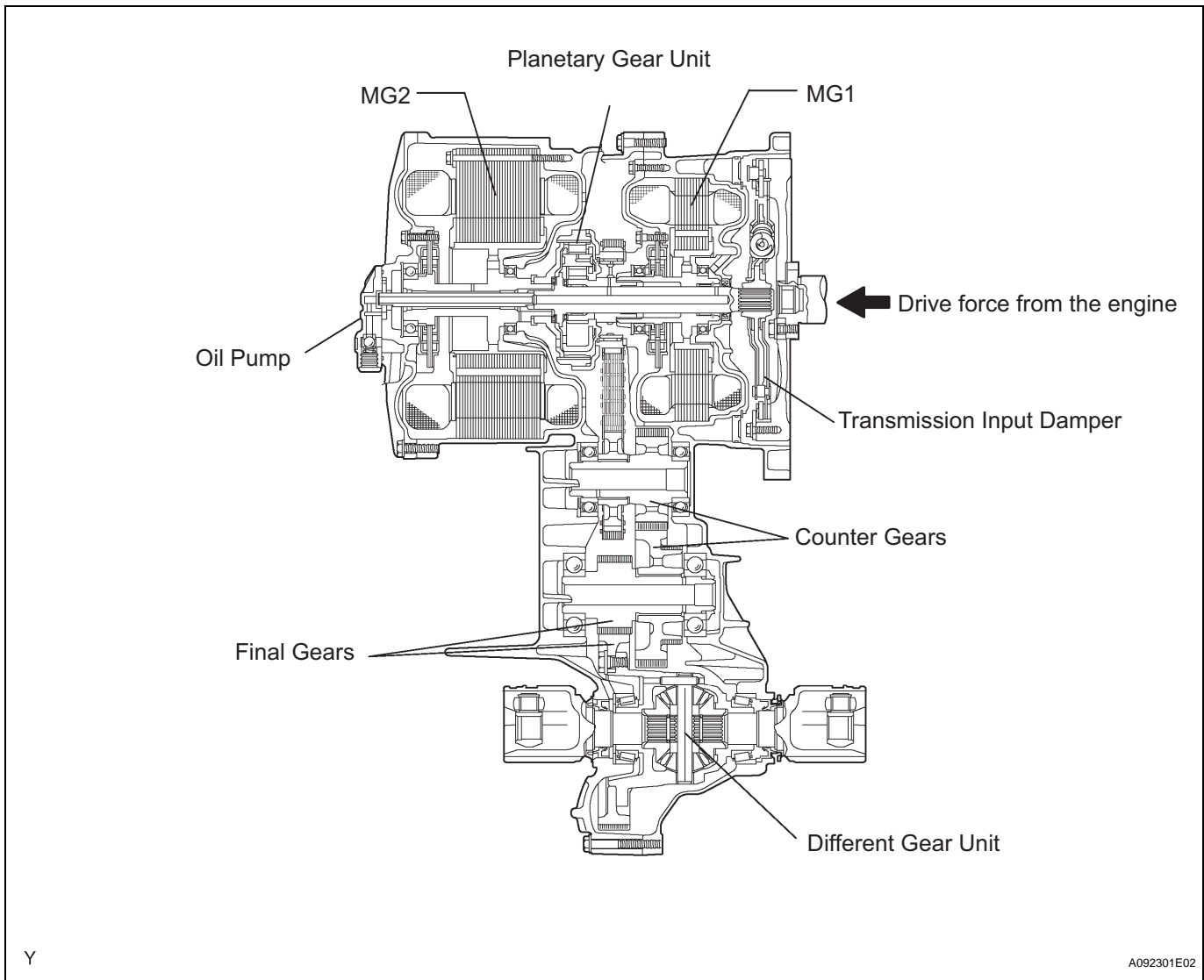

HV

DTC No.	INF Code	DTC Detection Condition	Trouble Area
P0A90	239	HV transaxle input malfunction (shaft damaged)	<ul style="list-style-type: none"> • Engine assembly • HV transaxle assembly (shaft or gear) • Transmission input damper • Wire harness or connector • HV control ECU
P0A90	241	HV transaxle input malfunction (torque limiter slipping)	<ul style="list-style-type: none"> • Engine assembly • HV transaxle assembly (shaft or gear) • Transmission input damper • Wire harness or connector • HV control ECU
P0A90	602	HV transaxle output malfunction	<ul style="list-style-type: none"> • Engine assembly • HV transaxle assembly (shaft or gear) • Transmission input damper • Wire harness or connector • HV control ECU

WIRING DIAGRAM

Refer to DTC P0A0F (INF 238) (see page [HV-135](#)).

INSPECTION PROCEDURE

1 READ OUTPUT DTC (ENGINE)

- (a) Connect the intelligent tester to the DLC3.
- (b) Turn the power switch ON (IG).
- (c) Turn the intelligent tester ON.
- (d) Enter the following menus: DIAGNOSIS / ENHANCED OBD II / DTC INFO / CURRENT CODES.
- (e) Read DTCs.

Result:
DTCs are output

YES → **GO TO RELEVANT DTC CHART**

NO

2 CHECK CRANKSHAFT PULLEY REVOLUTION

- (a) Turn the power switch OFF.
- (b) Jack up the vehicle.
- (c) Manually turn the crankshaft pulley to check if the crankshaft rotates.

OK:
The crankshaft rotates

NG → **Go to step 10**

OK

3 CHECK HARNESS AND CONNECTOR (ECM - CRANKSHAFT POSITION SENSOR)

HV

- (a) Disconnect the E4 ECM connector.

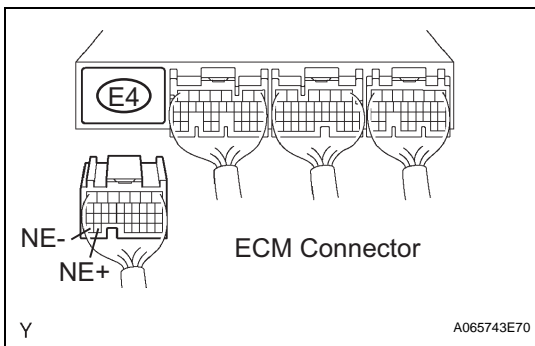

- (b) Disconnect the C7 crankshaft position sensor connector.
- (c) Measure the resistance between the wire harness side connectors.

Standard resistance (Check for open)

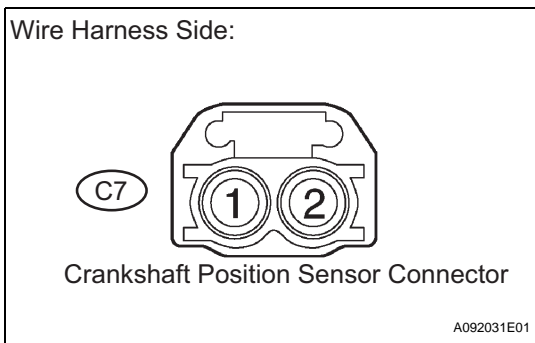

Tester Connection	Specified Condition
NE+ (E4-33) - Crankshaft position sensor (C7-1)	Below 1 Ω
NE- (E4-34) - Crankshaft position sensor (C7-2)	Below 1 Ω

Standard resistance (Check for short)

Tester Connection	Specified Condition
NE+ (E4-33) or Crankshaft position sensor (C7-1) - Body ground	10 kΩ or higher
NE- (E4-34) or Crankshaft position sensor (C7-2) - Body ground	10 kΩ or higher

- (d) Reconnect the crankshaft position sensor connector.
- (e) Reconnect the ECM connector.

NG REPAIR OR REPLACE HARNESS OR CONNECTOR

OK

4 CHECK HARNESS AND CONNECTOR (HYBRID VEHICLE CONTROL ECU - ECM)

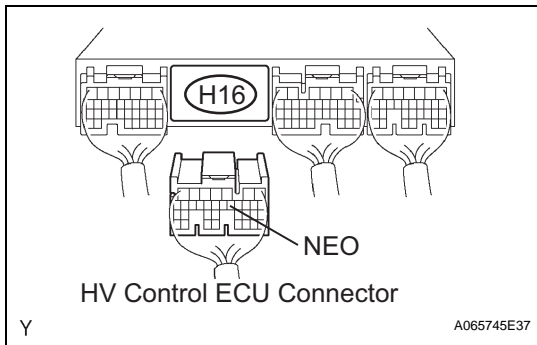

- (a) Disconnect the H16 HV control ECU connector.

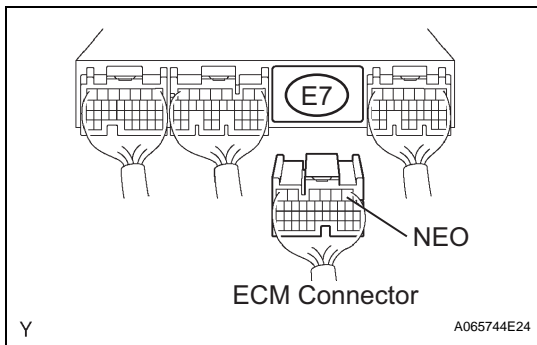

- (b) Disconnect the E7 ECM connector.
- (c) Measure the resistance between the wire harness side connectors.

Standard resistance (Check for open)

Tester Connection	Specified Condition
NEO (H16-12) - NEO (E7-1)	Below 1 Ω

Standard resistance (Check for short)

Tester Connection	Specified Condition
NEO (H16-12) or NEO (E7-1) - Body ground	10 Ω or higher

- (d) Reconnect the ECM connector.
- (e) Reconnect the HV control ECU connector.

NG REPAIR OR REPLACE HARNESS OR CONNECTOR

OK

5 CHECK AND CLEAR DTC (HV ECU)

- (a) Connect the intelligent tester to the DLC3.
- (b) Turn the power switch ON (IG).
- (c) Turn the intelligent tester ON.
- (d) Enter the following menus: DIAGNOSIS / OBD/MOBD / HV ECU / DTC INFO / CURRENT CODES.

- (e) Check and record the DTCs, the freeze frame data, and the information.
- (f) Clear the DTCs of the HV ECU.

GO

6 CHECK READY LIGHT

- (a) Connect the intelligent tester to the DLC3.
- (b) Turn the power switch ON (IG).
- (c) Turn the intelligent tester ON.
- (d) Enter the following menus: DIAGNOSIS / OBD/MOBD / HV ECU / DATA LIST.
- (e) Read the MG1 REV and ENGINE SPD values.
- (f) Turn the power switch ON (READY).

OK:

READY light turns ON

HINT:

If the READY light does not turn ON, and the reading on the intelligent tester shows DTC P0A90 (INF 239) (HV transaxle input malfunction [shaft damaged]), or the MG1 turns but the engine does not crank, replace the hybrid vehicle transaxle assembly.

NG

REPLACE HYBRID VEHICLE TRANSAXLE ASSEMBLY

OK

7 CHECK ENGINE REV-UP

- (a) Connect the intelligent tester to the DLC3.
- (b) Turn the power switch ON (IG).
- (c) Turn the intelligent tester ON.
- (d) Enter the following menus: DIAGNOSIS / OBD/MOBD / HV ECU / DATA LIST.
- (e) Read the MG1 REV and ENGINE SPD values.
- (f) With the READY light turned ON, depress the accelerator pedal for 10 seconds while the shift position is in P.

OK:

The engine revs up

HINT:

If the engine does not rev up, and the reading on the intelligent tester shows DTC P0A90 (INF 239) (HV transaxle input malfunction [shaft damaged]), or the MG1 turns but the engine does not crank, replace the hybrid vehicle transaxle assembly.

NG

REPLACE HYBRID VEHICLE TRANSAXLE ASSEMBLY

OK

HV

8 CHECK CREEP MOVEMENT

- (a) Connect the intelligent tester to the DLC3.
- (b) Turn the power switch ON (READY).
- (c) Jack up the vehicle.
- (d) Depress the brake pedal, move the selector lever to the D position, and release the brake pedal.

OK:**The wheels turn (creep movement)****HINT:**

If the wheels do not turn, and the reading on the intelligent tester shows DTC P0A90 (INF 602) (HV transaxle output malfunction), replace the hybrid vehicle transaxle assembly.

NG**REPLACE HYBRID VEHICLE TRANSAXLE ASSEMBLY****OK****9 CHECK ENGINE ACCELERATION SPEED**

- (a) Connect the intelligent tester to the DLC3.
- (b) While driving at the vehicle speed of more than 6 mph (10 km/h), fully depress the accelerator pedal to raise the engine speed.

OK:**The engine speed increases smoothly****HINT:**

If the engine over-revs or the reading on the intelligent tester shows DTC P0A90 (INF 241) (HV transaxle input malfunction [torque limiter slipping]), replace the transmission input damper.

NG**REPLACE TRANSMISSION INPUT DAMPER ASSEMBLY****OK**

PERFORM SIMULATION TEST. IF SYMPTOM IS NOT REPRODUCED, REPLACE HV TRANSAXLE AND HV CONTROL ECU

10 CHECK FRONT TIRE REVOLUTION

- (a) Turn the power switch ON (IG).
- (b) Depress the brake pedal, move the selector lever to the N position.
- (c) Jack up the vehicle.
- (d) Manually turn the crankshaft pulley to check if the front tires rotate.

OK:
The front tires rotate

NG → REPAIR OR REPLACE ENGINE ASSEMBLY

OK

REPAIR OR REPLACE HYBRID VEHICLE TRANSAXLE ASSEMBLY

DTC	P0A90-240	Drive Motor "A" Performance
------------	------------------	------------------------------------

DESCRIPTION

Refer to DTC P0A90 (INF 239) (see page [HV-321](#)).

DTC No.	INF Code	DTC Detection Condition	Trouble Area
P0A90	240	Generator locked	<ul style="list-style-type: none"> Hybrid vehicle generator

INSPECTION PROCEDURE

If the information (INF) code is present, replace the hybrid vehicle generator.

1	REPLACE HYBRID VEHICLE GENERATOR ASSEMBLY
----------	--

NEXT

COMPLETED

DTC	P0A90- 242	Drive Motor "A" Performance
------------	-----------------------	------------------------------------

DESCRIPTION

Refer to DTC P0A90 (INF 239) (see page [HV-321](#)).

DTC No.	INF Code	DTC Detection Condition	Trouble Area
P0A90	242	Planetary gear locked	<ul style="list-style-type: none"> • HV transaxle assembly

INSPECTION PROCEDURE

If the information (INF) code is present, replace the HV transaxle assembly.

1	REPLACE HYBRID VEHICLE TRANSAXLE ASSEMBLY
----------	--

- (a) Replace the hybrid vehicle transaxle assembly (see page [HX-69](#)).

NEXT

COMPLETED

DTC	P0A90-251	Drive Motor "A" Performance
------------	------------------	------------------------------------

DESCRIPTION

When three-phase alternating current flows through the three-phase windings of the stator coil, a rotating magnetic field is generated in the motor. The system controls the rotating magnetic field in accordance with the rotating position and speed of the rotor. As a result, the permanent magnets provided on the rotor are pulled in the rotating direction, which cause the generation of torque.

The generated torque is practically proportionate to the amount of current. Therefore, the system controls the speed of the motor by regulating the frequency of the alternating current. Furthermore, the system properly controls the rotating magnetic field and the angle of the rotor magnets in order to generate high torque in an efficient manner, even at high speeds.

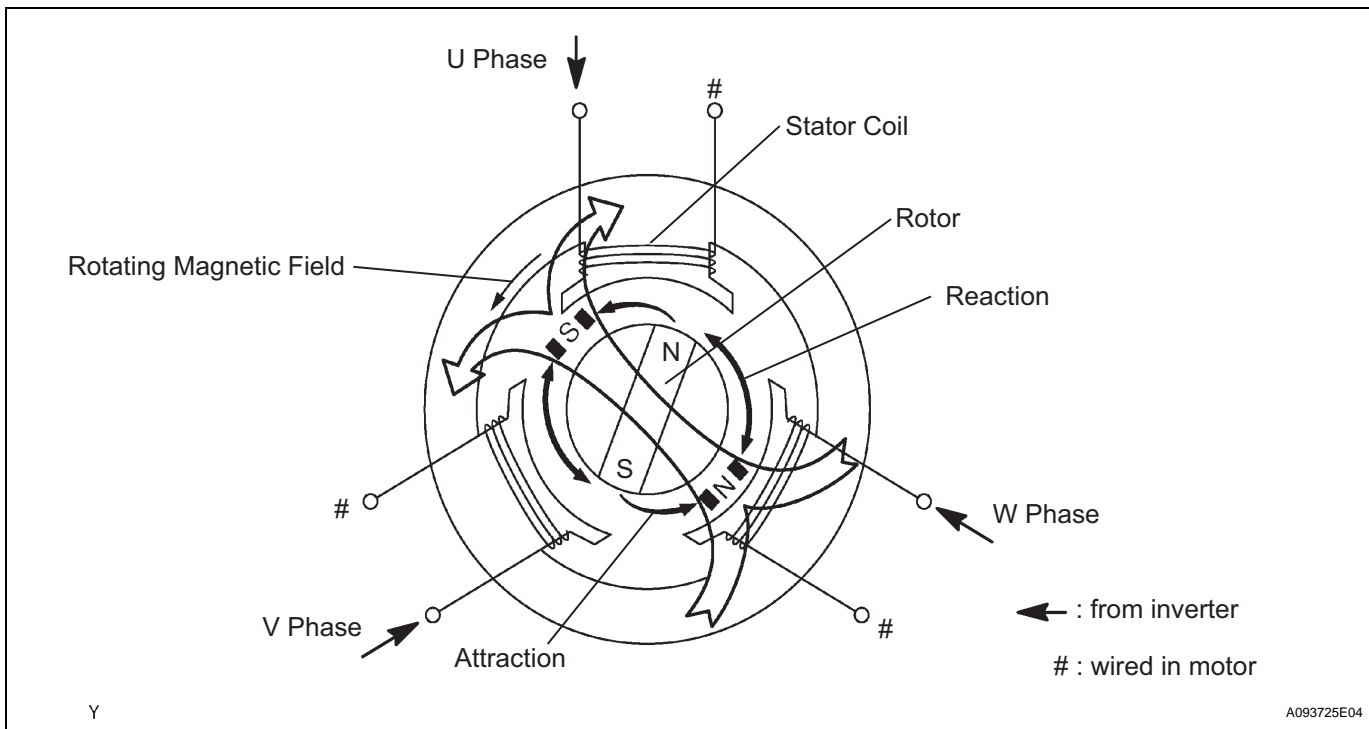

DTC No.	INF Code	DTC Detection Condition	Trouble Area
P0A90	251	MG2 magnetic force deterioration or same phase short circuit	<ul style="list-style-type: none"> Hybrid vehicle motor

MONITOR DESCRIPTION

The HV control ECU monitors the hybrid vehicle motor (MG2). If the HV control ECU detects a reduction in the magnetic force of the MG2 or an in-phase short, it interprets this as a MG2 failure. The HV control ECU then illuminates the MIL and sets a DTC.

MONITOR STRATEGY

Related DTCs	P0A90 (INF 251): Magnetic force deterioration/same phase short circuit
Required sensor / components	Hybrid vehicle motor, inverter, motor resolver
Frequency of operation	Continuous
Duration	TOYOTA's intellectual property
MIL operation	Immediately
Sequence of operation	None

HV

TYPICAL ENABLING CONDITIONS

The monitor will run whenever the following DTCs are not present	TOYOTA's intellectual property
Other conditions belong to TOYOTA's intellectual property	-

TYPICAL MALFUNCTION THRESHOLDS

TOYOTA's intellectual property	-
--------------------------------	---

COMPONENT OPERATING RANGE

Hybrid vehicle motor	DTC P0A90 (INF 251) is not detected
----------------------	-------------------------------------

INSPECTION PROCEDURE

1	READ OUTPUT DTC (HV ECU)
----------	---------------------------------

- (a) Connect the intelligent tester to the DLC3.
- (b) Turn the power switch ON (IG).
- (c) Turn the intelligent tester ON.
- (d) Enter the following menus: DIAGNOSIS / OBD/MOBD / HV ECU / DTC INFO / CURRENT CODES.
- (e) Read DTCs.

Result:

DTC P0A90 (INF 251) and other DTCs are output

HINT:

If any other codes besides P0A90 (INF 251) are output, perform troubleshooting for those DTCs first.

YES	GO TO RELEVANT DTC CHART
------------	---------------------------------

NO

REPLACE HYBRID VEHICLE MOTOR ASSEMBLY
--

DTC	P0A90-509	Drive Motor "A" Performance
------------	------------------	------------------------------------

DESCRIPTION

See the description of the MG1/MG2 (see page [HV-330](#)).

DTC No.	INF Code	DTC Detection Condition	Trouble Area
P0A90	509	MG2 system malfunction	<ul style="list-style-type: none"> • Hybrid vehicle motor • Inverter with converter assembly

MONITOR DESCRIPTION

The HV control ECU monitors the hybrid vehicle motor (MG2) system. If the HV control ECU detects a malfunction in the MG2 system, it illuminates the MIL and sets a DTC.

MONITOR STRATEGY

Related DTCs	P0A90 (INF 509): Motor system malfunction
Required sensor / components	Hybrid vehicle motor, inverter, motor resolver
Frequency of operation	Continuous
Duration	TOYOTA's intellectual property
MIL operation	Immediately
Sequence of operation	None

TYPICAL ENABLING CONDITIONS

The monitor will run whenever the following	TOYOTA's intellectual property
DTCs are not present No other condition	-

HV

TYPICAL MALFUNCTION THRESHOLDS

TOYOTA's intellectual property	-
--------------------------------	---

COMPONENT OPERATING RANGE

Hybrid vehicle motor	DTC P0A90 (INF 509) is not detected
----------------------	-------------------------------------

INSPECTION PROCEDURE

CAUTION:

- Before inspecting the high-voltage system, take safety precautions to prevent electrical shocks, such as wearing insulated gloves and removing the service plug grip. After removing the service plug grip, put it in your pocket to prevent other technicians from reconnecting it while you are servicing the high-voltage system.
- After disconnecting the service plug grip, wait for at least 5 minutes before touching any of the high-voltage connectors or terminals.

HINT:

At least 5 minutes are required to discharge the high-voltage condenser inside the inverter.

1	READ OUTPUT DTC (HV ECU)
----------	---------------------------------

(a) Connect the intelligent tester to the DLC3.

- (b) Turn the power switch ON (IG).
- (c) Turn the intelligent tester ON.
- (d) Enter the following menus: DIAGNOSIS / OBD/MOBD / HV ECU / DTC INFO / CURRENT CODES.
- (e) Read DTCs.

Result:

DTC P0A90 (INF 509) and other DTCs are output

HINT:

If any other codes besides P0A90 (INF 509) are output, perform troubleshooting for those DTCs first.

YES → **GO TO RELEVANT DTC CHART**

NO

2 INSPECT HYBRID VEHICLE MOTOR ASSEMBLY

CAUTION:

Wear insulated gloves before performing the following operation.

- (a) Turn the power switch OFF.
- (b) Remove the service plug grip (see page [HB-154](#)).

NOTICE:

Turning the power switch ON (READY) with the service plug grip removed could cause malfunction. Therefore, never turn the power switch ON (READY) in this state.

- (c) Remove the inverter cover (see page [HV-531](#)).
- (d) Disconnect the three-phase alternating current cable for the hybrid vehicle motor from the inverter.
- (e) Using a milliohm meter, measure the resistance between the three-phase alternating current cable terminals of the hybrid vehicle motor.

NOTICE:

If the motor temperature is too high, the resistance varies considerably, which hinders determining malfunction. Therefore, measure the resistance at a minimum 8 hours after the vehicle has been stopped.

Standard resistance

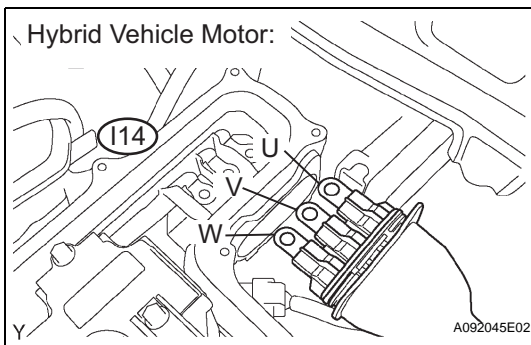

Tester Connection	Specified Condition*
U (I14-1) - V (I14-2)	Below 135 mΩ at 20°C
V (I14-2) - W (I14-3)	Below 135 mΩ at 20°C
W (I14-3) - U (I14-1)	Below 135 mΩ at 20°C

*: Apply the formula given below to correct the resistance.

$$R_{20} = R_t / \{1 + 0.00393 \times (T - 20)\}$$

R₂₀: Resistance converted to 20°C (mΩ)

R_t: Resistance between measured lines (mΩ)

T: Ambient air temperature during measurement (°C)

- (f) Calculate the difference between the maximum and minimum resistance between terminals U - V, V - W, and W - U.

Standard resistance:

Below 2 mΩ

- (g) Using a megohmmeter, measure the insulation resistance between the three-phase alternating current cable terminals of the hybrid vehicle motor and the body ground.

Standard resistance

Tester Connection	Specified Condition
U (I14-1) - Body ground	10 MΩ or higher
V (I14-2) - Body ground	10 MΩ or higher
W (I14-3) - Body ground	10 MΩ or higher

- (h) Reconnect the three-phase alternating current cable for the hybrid vehicle motor.
- (i) Reinstall the inverter cover (see page [HV-538](#)).
- (j) Reinstall the service plug grip (see page [HB-154](#)).

NG → **REPLACE HYBRID VEHICLE MOTOR ASSEMBLY**

OK

REPLACE INVERTER WITH CONVERTER ASSEMBLY

DTC	P0A90-604	Drive Motor "A" Performance
------------	------------------	------------------------------------

DTC	P0A90-605	Drive Motor "A" Performance
------------	------------------	------------------------------------

DESCRIPTION

See the description of the MG1/MG2 (see page [HV-330](#)).

DTC No.	INF Code	DTC Detection Condition	Trouble Area
P0A90	604	MG2 power balance malfunction (small power balance)	<ul style="list-style-type: none"> Battery current sensor Hybrid vehicle motor
P0A90	605	MG2 power balance malfunction (large power balance)	<ul style="list-style-type: none"> Battery current sensor Hybrid vehicle motor

MONITOR DESCRIPTION

The HV control ECU monitors the energy balance of the hybrid vehicle motor (MG2) system. If the HV control ECU detects a malfunction in the amount of electrical energy while the MG2 charges or discharges electricity, it illuminates the MIL and sets a DTC.

MONITOR STRATEGY

Related DTCs	P0A90 (INF 604 / 605): Hybrid vehicle motor / Power balance malfunction
Required sensor / components	Hybrid vehicle motor, motor resolver
Frequency of operation	Continuous
Duration	TOYOTA's intellectual property
MIL operation	Immediately
Sequence of operation	None

HV

TYPICAL ENABLING CONDITIONS

The monitor will run whenever the following DTCs are not present	TOYOTA's intellectual property
Other conditions belong to TOYOTA's intellectual property	-

TYPICAL MALFUNCTION THRESHOLDS

Hybrid vehicle motor (power balance)	Small or large
--------------------------------------	----------------

COMPONENT OPERATING RANGE

Hybrid vehicle motor DTC P0A90 (INF 604 / 605) is not detected	DTC P0A90 (INF 604 / 605) is not detected
--	---

INSPECTION PROCEDURE

CAUTION:

- Before inspecting the high-voltage system, take safety precautions to prevent electrical shocks, such as wearing insulated gloves and removing the service plug grip. After removing the service plug grip, put it in your pocket to prevent other technicians from reconnecting it while you are servicing the high-voltage system.
- After disconnecting the service plug grip, wait for at least 5 minutes before touching any of the high-voltage connectors or terminals.

HINT:

At least 5 minutes are required to discharge the high-voltage condenser inside the inverter.

1 READ OUTPUT DTC (HV BATTERY)

- (a) Connect the intelligent tester to the DLC3.
- (b) Turn the power switch ON (IG).
- (c) Turn the intelligent tester ON.
- (d) Enter the following menus: DIAGNOSIS / OBD/MOBD / HV BATTERY / DTC INFO / TROUBLE CODES.
- (e) Read DTCs.

Result:

DTCs are output

YES → **GO TO RELEVANT DTC CHART**

NO

2 READ OUTPUT DTC (HV ECU)

- (a) Connect the intelligent tester to the DLC3.
- (b) Turn the power switch ON (IG).
- (c) Turn the intelligent tester ON.
- (d) Enter the following menus: DIAGNOSIS / OBD/MOBD / HV ECU / DTC INFO / CURRENT CODES.
- (e) Read DTCs.

Result:

DTC P0A90 (INF 604 or 605) and other DTCs are output

HINT:

If any other codes besides P0A90 (INF 604 or 605) are output, perform troubleshooting for those DTCs first.

YES → **GO TO RELEVANT DTC CHART**

NO

3 INSPECT BATTERY CURRENT SENSOR

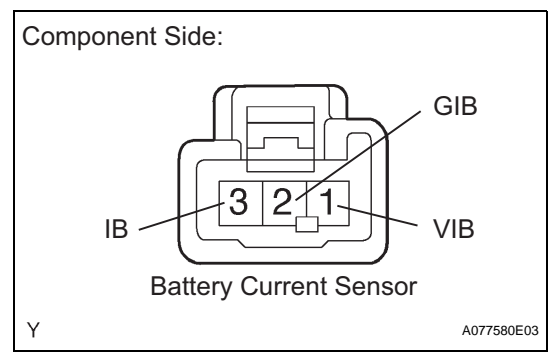

- (a) Remove the battery current sensor (see page [HB-142](#)).
- (b) Measure the resistance between terminals 1 (VIB) and 2 (GIB).

Standard resistance

Tester Connection	Specified Condition
Positive probe to terminal 1 (VIB) Negative probe to terminal 2 (GIB)	3.5 to 4.5 kΩ
Positive probe to terminal 2 (GIB) Negative probe to terminal 1 (VIB)	5 to 7 kΩ or more

- (c) Measure the resistance between terminals 1 (VIB) and 3 (IB).

HV

Standard resistance

Tester Connection	Specified Condition
Positive probe to terminal 1 (VIB) Negative probe to terminal 3 (IB)	3.5 to 4.5 k Ω
Positive probe to terminal 3 (IB) Negative probe to terminal 1 (VIB)	5 to 7 k Ω or more

- (d) Measure the resistance between terminals 2 (GIB) and 3 (IB).

Standard resistance:

0.2 k Ω or less

NOTICE:

Even if the probes are changed around, the resistance will not vary.

- (e) Reinstall the battery current sensor (see page [HB-143](#)).

NG

REPLACE BATTERY CURRENT SENSOR

OK

REPLACE HYBRID VEHICLE MOTOR ASSEMBLY

DTC	P0A92- 261	Hybrid Generator Performance
------------	-----------------------	-------------------------------------

DESCRIPTION

See the description of the MG1/MG2 (see page [HV-330](#)).

DTC No.	INF Code	DTC Detection Condition	Trouble Area
P0A92	261	MG1 magnetic force deterioration or same phase short circuit	<ul style="list-style-type: none"> Hybrid vehicle generator

MONITOR DESCRIPTION

The HV control ECU monitors the hybrid vehicle generator (MG1). If the HV control ECU detects a reduction in the magnetic force of the MG1 or an in-phase short, it interprets this as a MG1 failure. The HV control ECU then illuminates the MIL and sets a DTC.

MONITOR STRATEGY

Related DTCs	P0A92 (INF 261): Magnetic force deterioration/same phase short circuit
Required sensor / components	Hybrid vehicle generator, inverter, generator resolver
Frequency of operation	Continuous
Duration	TOYOTA's intellectual property
MIL operation	Immediately
Sequence of operation	None

TYPICAL ENABLING CONDITIONS

The monitor will run whenever the following DTCs are not present	TOYOTA's intellectual property
Other conditions belong to TOYOTA's intellectual property	-

TYPICAL MALFUNCTION THRESHOLDS

TOYOTA's intellectual property	-
--------------------------------	---

COMPONENT OPERATING RANGE

Hybrid vehicle generator	DTC P0A92 (INF 261) is not detected
--------------------------	-------------------------------------

INSPECTION PROCEDURE

1	READ OUTPUT DTC (HV ECU)
----------	---------------------------------

- (a) Connect the intelligent tester to the DLC3.
- (b) Turn the power switch ON (IG).
- (c) Turn the intelligent tester ON.
- (d) Enter the following menus: DIAGNOSIS / OBD/MOBD / HV ECU / DTC INFO / CURRENT CODES.
- (e) Read DTCs.

Result:

DTC P0A92 (INF 261) and other DTCs are output

HINT:

If any other codes besides P0A92 (INF 261) are output, perform troubleshooting for those DTCs first.

YES

GO TO RELEVANT DTC CHART

NO

REPLACE HYBRID VEHICLE GENERATOR ASSEMBLY

DTC	P0A92-521	Hybrid Generator Performance
------------	------------------	-------------------------------------

DESCRIPTION

See the description of the MG1/MG2 (see page [HV-330](#)).

DTC No.	INF Code	DTC Detection Condition	Trouble Area
P0A92	521	MG1 system malfunction	<ul style="list-style-type: none"> Hybrid vehicle generator Inverter with converter assembly

MONITOR DESCRIPTION

The HV control ECU monitors the hybrid vehicle generator (MG1) system. If the HV control ECU detects a malfunction in the MG1 system, it illuminates the MIL and sets a DTC.

MONITOR STRATEGY

Related DTCs	P0A92 (INF 521): Generator system malfunction
Required sensor / components	Hybrid vehicle generator, inverter, generator resolver
Frequency of operation	Continuous
Duration	TOYOTA's intellectual property
MIL operation	Immediately
Sequence of operation	None

TYPICAL ENABLING CONDITIONS

The monitor will run whenever the following DTCs are not present	TOYOTA's intellectual property
No other condition	-

TYPICAL MALFUNCTION THRESHOLDS

TOYOTA's intellectual property	-
--------------------------------	---

COMPONENT OPERATING RANGE

Hybrid vehicle generator	DTC P0A92 (INF 521) is not detected
--------------------------	-------------------------------------

INSPECTION PROCEDURE

CAUTION:

- Before inspecting the high-voltage system, take safety precautions to prevent electrical shocks, such as wearing insulated gloves and removing the service plug grip. After removing the service plug grip, put it in your pocket to prevent other technicians from reconnecting it while you are servicing the high-voltage system.
- After disconnecting the service plug grip, wait for at least 5 minutes before touching any of the high-voltage connectors or terminals.

HINT:

At least 5 minutes are required to discharge the high-voltage condenser inside the inverter.

1	READ OUTPUT DTC (HV ECU)
----------	---------------------------------

- (a) Connect the intelligent tester to the DLC3.

- (b) Turn the power switch ON (IG).
- (c) Turn the intelligent tester ON.
- (d) Enter the following menus: DIAGNOSIS / OBD/MOBD / HV ECU / DTC INFO / CURRENT CODES.
- (e) Read DTCs.

Result:

DTC P0A92 (INF 521) and other DTCs are output

HINT:

If any other codes besides P0A92 (INF 521) are output, perform troubleshooting for those DTCs first.

YES GO TO RELEVANT DTC CHART

NO

2 INSPECT HYBRID VEHICLE GENERATOR ASSEMBLY

CAUTION:

Wear insulated gloves before performing the following operation.

- (a) Turn the power switch OFF.
- (b) Remove the service plug grip (see page [HB-154](#)).

NOTICE:

Turning the power switch ON (READY) with the service plug grip removed could cause malfunction. Therefore, never turn the power switch ON (READY) in this state.

- (c) Remove the inverter cover (see page [HV-531](#)).
- (d) Disconnect the three-phase alternating current cable for the hybrid vehicle generator from the inverter.
- (e) Using milliohm meter, measure the resistance between the three-phase alternating current cable terminals of the hybrid vehicle generator.

NOTICE:

If the generator temperature is too high, the resistance varies considerably, which hinders determining malfunction. Therefore, measure the resistance at a minimum 8 hours after the vehicle has been stopped.

Standard resistance

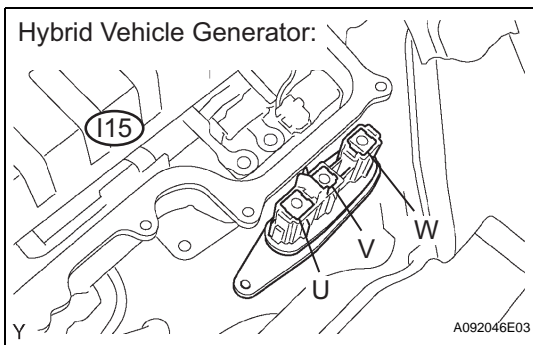

Tester Connection	Specified Condition*
U (I15-1) - V (I15-2)	Below 109 mΩ at 20°C
V (I15-2) - W (I15-3)	Below 109 mΩ at 20°C
W (I15-3) - U (I15-1)	Below 109 mΩ at 20°C

*: Apply the formula given below to correct the resistance.

$$R_{20} = R_t / \{1 + 0.00393 \times (T - 20)\}$$

R₂₀: Resistance converted to 20°C (mΩ)

R_t: Resistance between measured lines (mΩ)

T: Ambient air temperature during measurement (°C)

- (f) Calculate the difference between the maximum and minimum resistance between terminals U - V, V - W, and W - U.

Standard resistance:

Below 2 mΩ

- (g) Using a megohmmeter, measure the insulation resistance between the three-phase alternating current cable terminals of the hybrid vehicle generator and the body ground.

Standard resistance

Tester Connection	Specified Condition
U (I15-1) - Body ground	10 MΩ or higher
V (I15-2) - Body ground	10 MΩ or higher
W (I15-3) - Body ground	10 MΩ or higher

- (h) Reconnect the three-phase alternating current cable for the hybrid vehicle generator.
- (i) Reinstall the inverter cover (see page [HV-538](#)).
- (j) Reinstall the service plug grip (see page [HB-154](#)).

NG → **REPLACE HYBRID VEHICLE GENERATOR ASSEMBLY**

OK

REPLACE INVERTER WITH CONVERTER ASSEMBLY

DTC	P0A92-606	Hybrid Generator Performance
------------	------------------	-------------------------------------

DTC	P0A92-607	Hybrid Generator Performance
------------	------------------	-------------------------------------

DESCRIPTION

See the description of the MG1/MG2 (see page [HV-330](#)).

DTC No.	INF Code	DTC Detection Condition	Trouble Area
P0A92	606	MG1 power balance malfunction (small power balance)	<ul style="list-style-type: none"> Battery current sensor Hybrid vehicle generator
P0A92	607	MG1 power balance malfunction (large power balance)	<ul style="list-style-type: none"> Battery current sensor Hybrid vehicle generator

MONITOR DESCRIPTION

The HV control ECU monitors the energy balance of the hybrid vehicle generator (MG1) system. If the HV control ECU detects a malfunction in the amount of electrical energy while the MG1 charges or discharges electricity, it illuminates the MIL and sets a DTC.

MONITOR STRATEGY

Related DTCs	P0A92 (INF 606 / 607): Hybrid vehicle generator / Power balance malfunction
Required sensor / components	Hybrid vehicle generator, generator resolver
Frequency of operation	Continuous
Duration	TOYOTA's intellectual property
MIL operation	Immediately
Sequence of operation	None

HV

TYPICAL ENABLING CONDITIONS

The monitor will run whenever the following DTCs are not present	TOYOTA's intellectual property
Other conditions belong to TOYOTA's intellectual property	-

TYPICAL MALFUNCTION THRESHOLDS

Hybrid vehicle generator (power balance)	Small or large
--	----------------

COMPONENT OPERATING RANGE

Hybrid vehicle generator	DTC P0A92 (INF 606 / 607) is not detected
--------------------------	---

INSPECTION PROCEDURE

CAUTION:

- Before inspecting the high-voltage system, take safety precautions to prevent electrical shocks, such as wearing insulated gloves and removing the service plug grip. After removing the service plug grip, put it in your pocket to prevent other technicians from reconnecting it while you are servicing the high-voltage system.
- After disconnecting the service plug grip, wait for at least 5 minutes before touching any of the high-voltage connectors or terminals.

HINT:

At least 5 minutes are required to discharge the high-voltage condenser inside the inverter.

1 READ OUTPUT DTC (HV BATTERY)

- (a) Connect the intelligent tester to the DLC3.
- (b) Turn the power switch ON (IG).
- (c) Turn the intelligent tester ON.
- (d) Enter the following menus: DIAGNOSIS / OBD/MOBD / HV BATTERY / DTC INFO / TROUBLE CODES.
- (e) Read DTCs.

Result:

DTCs are output

YES → **GO TO RELEVANT DTC CHART**

NO

2 READ OUTPUT DTC (HV ECU)

- (a) Connect the intelligent tester to the DLC3.
- (b) Turn the power switch ON (IG).
- (c) Turn the intelligent tester ON.
- (d) Enter the following menus: DIAGNOSIS / OBD/MOBD / HV ECU / DTC INFO / CURRENT CODES.
- (e) Read DTCs.

Result:

DTC P0A92 (INF 606 or 607) and other DTCs are output

HINT:

If any other codes besides P0A92 (INF 606 or 607) are output, perform troubleshooting for those DTCs first.

YES → **GO TO RELEVANT DTC CHART**

NO

3 INSPECT BATTERY CURRENT SENSOR

Component Side:

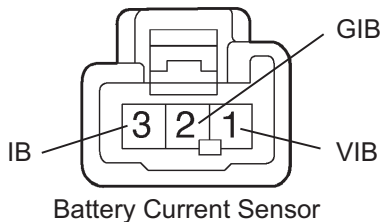

Y

A077580E03

- (a) Remove the battery current sensor (see page [HB-142](#)).
- (b) Measure the resistance between terminals 1 (VIB) and 2 (GIB).

Standard resistance

Tester Connection	Specified Condition
Positive probe to terminal 1 (VIB) Negative probe to terminal 2 (GIB)	3.5 to 4.5 kΩ
Positive probe to terminal 2 (GIB) Negative probe to terminal 1 (VIB)	5 to 7 kΩ or more

- (c) Measure the resistance between terminals 1 (VIB) and 3 (IB).

HV

Standard resistance

Tester Connection	Specified Condition
Positive probe to terminal 1 (VIB) Negative probe to terminal 3 (IB)	3.5 to 4.5 k Ω
Positive probe to terminal 3 (IB) Negative probe to terminal 1 (VIB)	5 to 7 k Ω or more

- (d) Measure the resistance between terminals 2 (GIB) and 3 (IB).

Standard resistance:

0.2 k Ω or less

NOTICE:

Even if the probes are changed around, the resistance will not vary.

- (e) Reinstall the battery current sensor (see page [HB-143](#)).

NG

REPLACE BATTERY CURRENT SENSOR

OK

REPLACE HYBRID VEHICLE GENERATOR ASSEMBLY

DTC	P0A93-346	Inverter Cooling System Performance
------------	------------------	--

DTC	P0A93-347	Inverter Cooling System Performance
------------	------------------	--

DESCRIPTION

The inverter converts the high-voltage direct current of the HV battery into the alternating current for the MG1 and the MG2. The inverter generates heat during the conversion process, and this heat could damage the inverter if a cooling system is unavailable. Therefore, similar to the MG1 and the MG2, the inverter is cooled by a dedicated cooling system, which consists of an electric water pump, cooling fan, and radiator. This cooling system is independent of the engine cooling system.

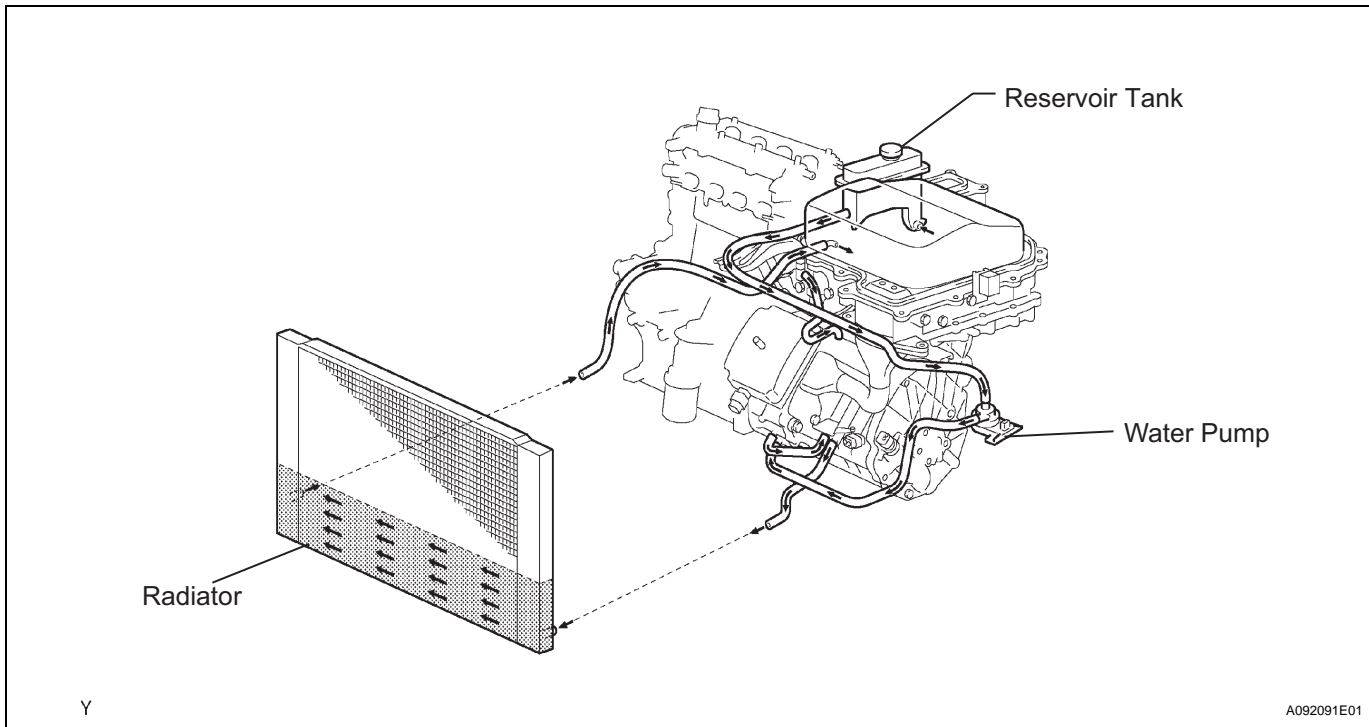

The HV control ECU monitors the electric water pump, cooling fan and cooling system, and detects a malfunction.

DTC No.	INF Code	DTC Detection Condition	Trouble Area
P0A93	346	Inverter cooling system malfunction (water pump system malfunction)	<ul style="list-style-type: none"> • Wire harness or connector • Inverter cooling system • Water pump with motor assembly • Cooling fan motor • No. 2 cooling fan motor • Inverter with converter assembly
P0A93	347	Inverter cooling system malfunction (electric cooling fan system malfunction)	<ul style="list-style-type: none"> • Wire harness or connector • Inverter cooling system • Water pump with motor assembly • Cooling fan motor • No. 2 cooling fan motor • Inverter with converter assembly

MONITOR DESCRIPTION

If the HV control ECU detects a malfunction in the electric water pump, fan, or radiator, it illuminates the MIL and sets a DTC.

MONITOR STRATEGY

Related DTCs	P0A93 (INF 346 / 347): Inverter cooling system performance / Inverter cooling system
Required sensor / components	Water pump, radiator fan, inverter, boost converter, DC / DC converter
Frequency of operation	Continuous
Duration	TOYOTA's intellectual property
MIL operation	Immediately
Sequence of operation	None

TYPICAL ENABLING CONDITIONS

The monitor will run whenever the following DTCs are not present	TOYOTA's intellectual property
No other condition	-

TYPICAL MALFUNCTION THRESHOLDS

TOYOTA's intellectual property	-
--------------------------------	---

COMPONENT OPERATING RANGE

Water pump Radiator fan	DTC P0A93 (INF 346 / 347) is not detected
----------------------------	---

INSPECTION PROCEDURE

HV

1 CHECK QUANTITY OF HV COOLANT

- (a) Check that there is a sufficient amount of coolant for the inverter.

OK:

There is a sufficient amount of coolant for the inverter

NG → **ADD HV COOLANT**

OK

2 CHECK COOLANT HOSE

- (a) Check that the hoses of the cooling system are not bent or clogged (refer to the cooling system).

OK:

The hoses of the cooling system are not bent or clogged

NG → **CORRECT TO NORMAL CONDITION**

OK

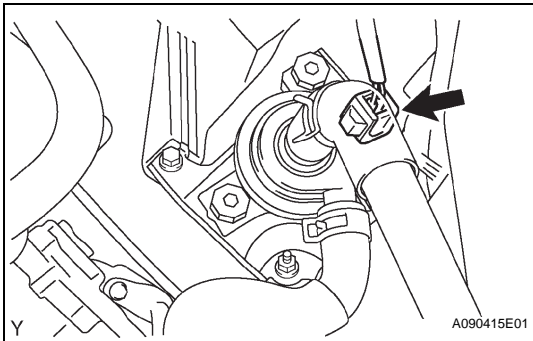
3 CHECK CONNECTION CONDITION OF WATER PUMP CONNECTOR (LOOSENESS AND POOR CONTACT)

- (a) Check the connection condition of the water pump connector.

OK:

Connector has been connected securely and there is no poor connection.

NG

CONNECT SECURELY

OK

4 CHECK WATER PUMP WITH MOTOR ASSEMBLY

- (a) Turn the power switch ON (IG).
 (b) Check the operation of the water pump.

OK:

Coolant is sloshing in the reservoir tank

NG

REPLACE WATER PUMP WITH MOTOR ASSEMBLY

OK

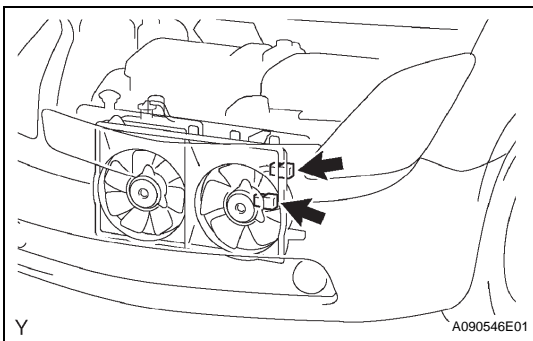
5 CHECK CONNECTION CONDITION OF COOLING FAN MOTOR CONNECTOR (LOOSENESS AND POOR CONTACT)

- (a) Check the connection condition of the cooling fan motor connectors.

OK:

Connectors have been connected securely and there is no poor connection.

NG

CONNECT SECURELY

OK

6 INSPECT COOLING FAN MOTOR

- (a) Inspect the cooling fan motor (see page [CO-5](#)).

NG

REPLACE COOLING FAN MOTOR AND ADD ENGINE COOLANT

OK

7 INSPECT NO. 2 COOLING FAN MOTOR

(a) Inspect the No. 2 cooling fan motor (see page [CO-5](#)).

NG

REPLACE NO. 2 COOLING FAN MOTOR AND
ADD ENGINE COOLANT

OK

REPLACE INVERTER WITH CONVERTER ASSEMBLY

DTC	P0A94-442	DC / DC Converter Performance
------------	------------------	--------------------------------------

DESCRIPTION

The boost converter contains a booster IPM (Intelligent Power Module), which includes an IGBT (Insulated Gate Bipolar Transistor) and a reactor. The HV control ECU actuates the IGBT, which controls the current in the reactor.

The boost converter boosts the high-voltage direct current rated at 201.6 V to an approximate direct current voltage of 500 V. The inverter converts the voltage that has been boosted by the boost converter into alternating current, which is used for driving the MG1/MG2. When the MG1/MG2 operates as a generator, the alternating current of approximately 500 V from the MG1/MG2 is converted into direct current by the inverter.

Then, the boost converter drops this voltage to a direct current voltage rated at 201.6 V in order to charge the HV battery.

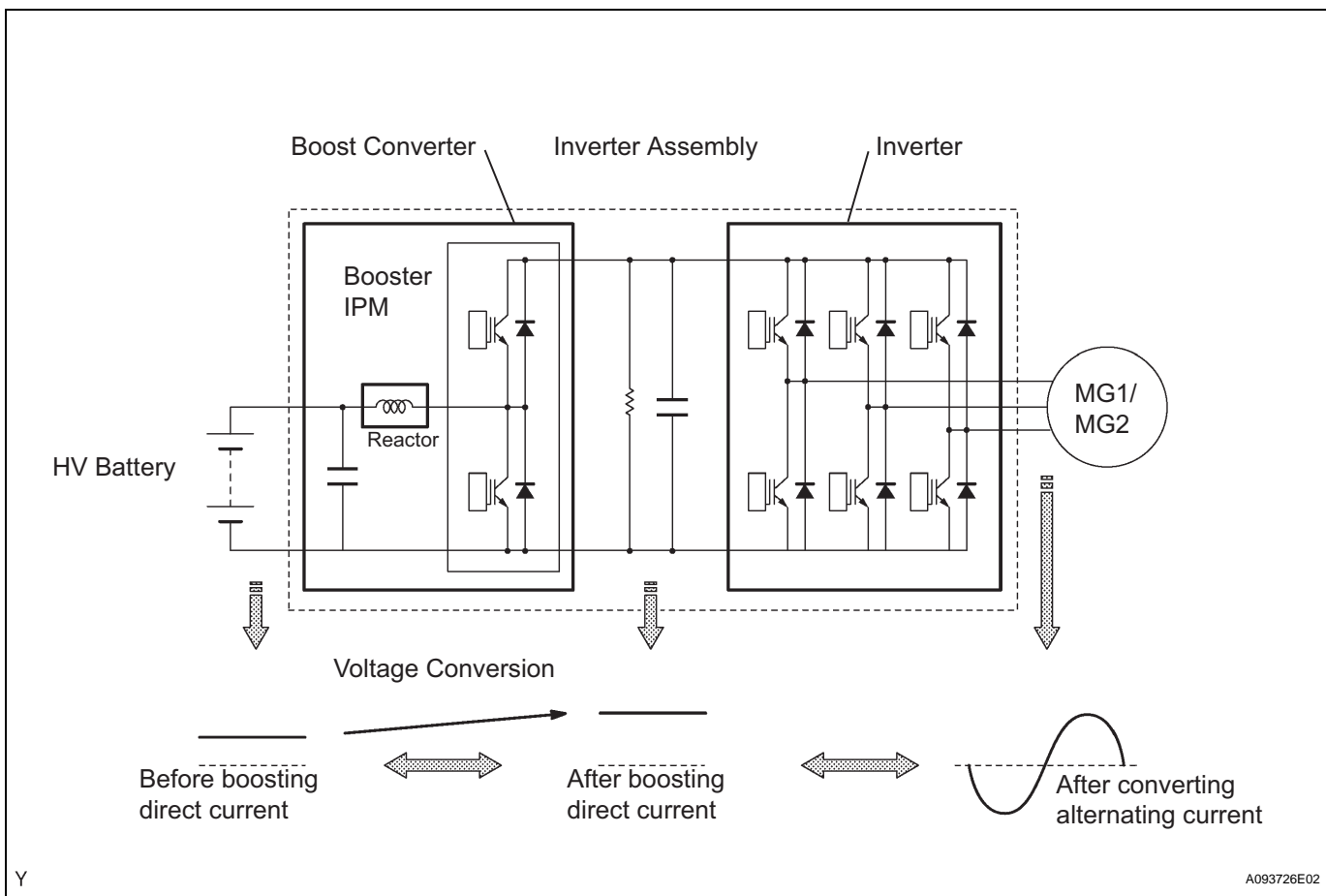

The HV control ECU uses a voltage sensor that is built into the boost converter to detect the high voltage (VL) before it is boosted. Also, it uses a voltage sensor that is built into the inverter to detect the high voltage (VH) after it has been boosted.

Based on the voltage before and after it has been boosted, the HV control ECU boosts it to a target voltage by controlling the operation of the boost converter.

DTC No.	INF Code	DTC Detection Condition	Trouble Area
P0A94	442	Abnormal voltage execution value	<ul style="list-style-type: none"> Inverter with converter assembly

INSPECTION PROCEDURE**1 READ OUTPUT DTC (HV ECU)**

- (a) Connect the intelligent tester to the DLC3.
- (b) Turn the power switch ON (IG).
- (c) Turn the intelligent tester ON.
- (d) Enter the following menus: DIAGNOSIS / OBD/MOBD / HV ECU / DTC INFO / CURRENT CODES.
- (e) Read DTCs.

Result:

DTC P0A94 (INF 442) and other DTCs are output

HINT:

If any other codes besides P0A94 (INF 442) are output, perform troubleshooting for those DTCs first.

YES**GO TO RELEVANT DTC CHART****NO****REPLACE INVERTER WITH CONVERTER ASSEMBLY**

DTC	P0A94-545	DC / DC Converter Performance
DTC	P0A94-546	DC / DC Converter Performance

DESCRIPTION

See the description of the boost converter (see page [HV-350](#)).

If the boost converter detects a circuit malfunction or over-voltage, the boost converter transmits this information to the OVL terminal of the HV control ECU via the boost converter over-voltage signal line. The HV control ECU monitors the boost converter over-voltage signal line and detects a malfunction.

DTC No.	INF Code	DTC Detection Condition	Trouble Area
P0A94	545	Open or GND short in boost converter over-voltage (OVL) signal circuit	<ul style="list-style-type: none"> Wire harness or connector Inverter with converter assembly
P0A94	546	+B short in boost converter over-voltage (OVL) signal circuit	<ul style="list-style-type: none"> Wire harness or connector Inverter with converter assembly

MONITOR DESCRIPTION

The HV control ECU monitors the boost converter over-voltage (OVL) signal line. If the HV control ECU detects an open or short malfunction of the OVL signal circuit, the HV control ECU illuminates the MIL and sets a DTC.

MONITOR STRATEGY

Related DTCs	P0A94 (INF 545 / 546): Boost converter / Converter OVL detection
Required sensor / components	Boost converter
Frequency of operation	Continuous
Duration	TOYOTA's intellectual property
MIL operation	Immediately
Sequence of operation	None

TYPICAL ENABLING CONDITIONS

The monitor will run whenever the following DTCs are not present	TOYOTA's intellectual property
Other conditions belong to TOYOTA's intellectual property	-

TYPICAL MALFUNCTION THRESHOLDS

Boost converter over-voltage (OVL) signal circuit	Open or short
---	---------------

COMPONENT OPERATING RANGE

Boost converter	DTC P0A94 (INF 545 / 546) is not detected
-----------------	---

WIRING DIAGRAM

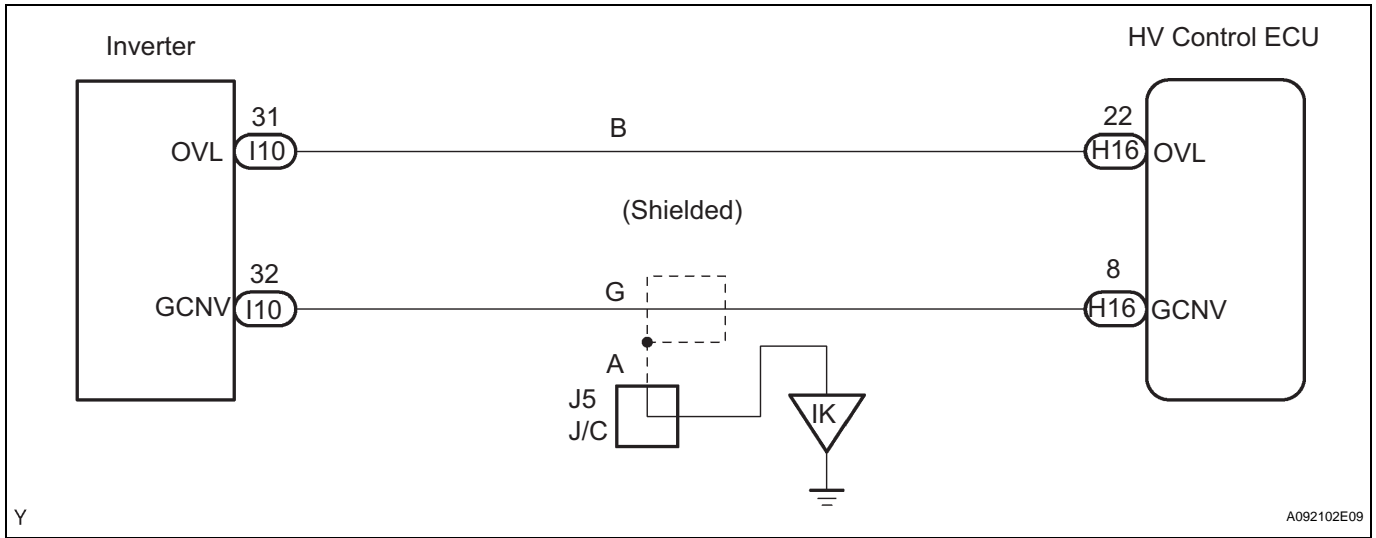

INSPECTION PROCEDURE

CAUTION:

- Before inspecting the high-voltage system, take safety precautions to prevent electrical shocks, such as wearing insulated gloves and removing the service plug grip. After removing the service plug grip, put it in your pocket to prevent other technicians from reconnecting it while you are servicing the high-voltage system.
- After disconnecting the service plug grip, wait for at least 5 minutes before touching any of the high-voltage connectors or terminals.

HINT:

At least 5 minutes are required to discharge the high-voltage condenser inside the inverter.

1 CHECK HARNESS AND CONNECTOR (HYBRID VEHICLE CONTROL ECU - INVERTER)

HV

CAUTION:

Wear insulated gloves before performing the following operation.

- Turn the power switch OFF.
- Remove the service plug grip (see page [HB-154](#)).

NOTICE:

Turning the power switch ON (READY) with the service plug grip removed could cause malfunction. Therefore, never turn the power switch ON (READY) in this state.

- Disconnect the H16 HV control ECU connector.
- Remove the inverter cover (see page [HV-531](#)).

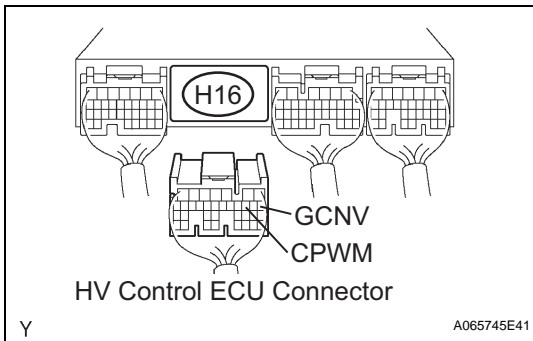

Y

A065745E41

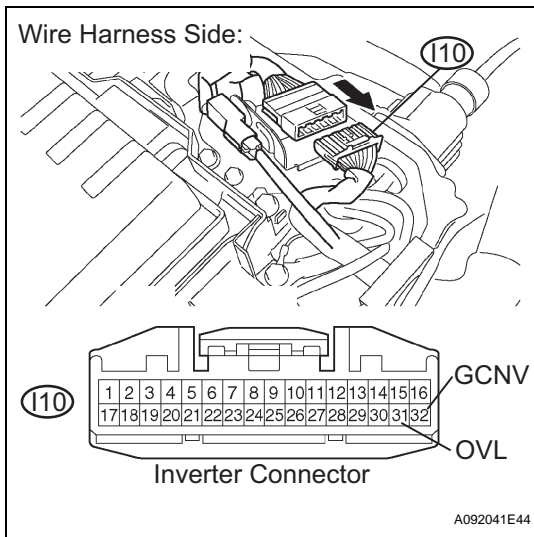

- (e) Disconnect the I10 inverter connector.
- (f) Turn the power switch ON (IG).
HINT:
DTCs for the interlock switch system are output when turning the power switch ON (IG) with both service plug grip and inverter cover removed.
- (g) Measure the voltage between the terminals of the HV control ECU connector and body ground.

Standard voltage

Tester Connection	Specified Condition
OVL (H16-22) - Body ground	Below 1 V
GCNV (H16-8) - Body ground	Below 1 V

- (h) Turn the power switch OFF.
- (i) Measure the resistance between the wire harness side connectors.

Standard resistance (Check for open)

Tester Connection	Specified Condition
OVL (H16-22) - OVL (I10-31)	Below 1 Ω
GCNV (H16-8) - GCNV (I10-32)	Below 1 Ω

Standard resistance (Check for short)

Tester Connection	Specified Condition
OVL (H16-22) or OVL (I10-31) - Body ground	10 kΩ or higher
GCNV (H16-8) or GCNV (I10-32) - Body ground	10 kΩ or higher

- (j) Reconnect the inverter connector.
- (k) Reconnect the HV control ECU connector.
- (l) Reinstall the inverter cover (see page HV-538).
- (m) Reinstall the service plug grip (see page HB-154).

NG → **REPAIR OR REPLACE HARNESS OR CONNECTOR**

OK

REPLACE INVERTER WITH CONVERTER ASSEMBLY

HV

DTC	P0A94-547	DC / DC Converter Performance
DTC	P0A94-548	DC / DC Converter Performance
DTC	P0A94-549	DC / DC Converter Performance

DESCRIPTION

See the description of the booster converter (see page [HV-350](#)).

If the boost converter detects a circuit malfunction or over-voltage, the boost converter transmits that information to the OVL terminal of the HV control ECU via the boost converter over-voltage signal line.

DTC No.	INF Code	DTC Detection Condition	Trouble Area
P0A94	547	Boost converter over-voltage (OVL) signal detection (over-voltage by HV control ECU malfunction)	<ul style="list-style-type: none"> • Wire harness or connector • HV transaxle assembly • Hybrid vehicle motor • Hybrid vehicle generator • HV control ECU • Inverter with converter assembly
P0A94	548	Boost converter over-voltage (OVL) signal detection (over-voltage by inverter assembly malfunction)	<ul style="list-style-type: none"> • Wire harness or connector • HV transaxle assembly • Hybrid vehicle motor • Hybrid vehicle generator • HV control ECU • Inverter with converter assembly
P0A94	549	Boost converter over-voltage (OVL) signal detection (over-voltage by HV transaxle assembly malfunction)	<ul style="list-style-type: none"> • Wire harness or connector • HV transaxle assembly • Hybrid vehicle motor • Hybrid vehicle generator • HV control ECU • Inverter with converter assembly

HV

MONITOR DESCRIPTION

If the boost converter detects over-voltage, it transmits a boost converter over-voltage signal to the HV control ECU. Upon receiving this signal, the HV control ECU illuminates the MIL and sets a DTC.

MONITOR STRATEGY

Related DTCs	P0A94 (INF 547 / 548 / 549): OVL detection over-voltage
Required sensor / components	Boost converter
Frequency of operation	Continuous
Duration	TOYOTA's intellectual property
MIL operation	Immediately
Sequence of operation	None

TYPICAL ENABLING CONDITIONS

The monitor will run whenever the following DTCs are not present	TOYOTA's intellectual property
Other conditions belong to TOYOTA's intellectual property	-

TYPICAL MALFUNCTION THRESHOLDS

Boost converter	Over-voltage
-----------------	--------------

COMPONENT OPERATING RANGE

Boost converter	DTC P0A94 (INF 547 / 548 / 549) is not detected
-----------------	---

WIRING DIAGRAM

Refer to DTC P0A78 (INF 279) (see page [HV-235](#)).

INSPECTION PROCEDURE

CAUTION:

- Before inspecting the high-voltage system, take safety precautions to prevent electrical shocks, such as wearing insulated gloves and removing the service plug grip. After removing the service plug grip, put it in your pocket to prevent other technicians from reconnecting it while you are servicing the high-voltage system.
- After disconnecting the service plug grip, wait for at least 5 minutes before touching any of the high-voltage connectors or terminals.

HINT:

At least 5 minutes are required to discharge the high-voltage condenser inside the inverter.

1	CONFIRM INFORMATION (EXCLUSIVE INFO 3)
----------	---

- (a) Connect the intelligent tester to the DLC3.
- (b) Turn the power switch ON (IG).
- (c) Turn the intelligent tester ON.
- (d) Enter the following menus: DIAGNOSIS / OBD/MOBD / HV ECU / DTC INFO / CURRENT CODES.
- (e) Select DTC P0A94 to display its freeze frame data.
- (f) Select the item that has INF code 547, 548, or 549 from among INFORMATION 1 to 5, and press ENTER.
- (g) Read EXCLUSIVE INFO 3.

Result:

-32 to 32 (during driving without battery power)

HINT:

If the value is inside the range shown above, DTCs other than P0A78 (INF 547, 548 and 549) have been detected as well. Perform troubleshooting for those DTCs first.

YES	GO TO RELEVANT DTC CHART
------------	---------------------------------

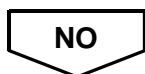

2 CHECK CONNECTION CONDITION OF HYBRID VEHICLE CONTROL ECU CONNECTOR (LOOSENESS AND POOR CONTACT)

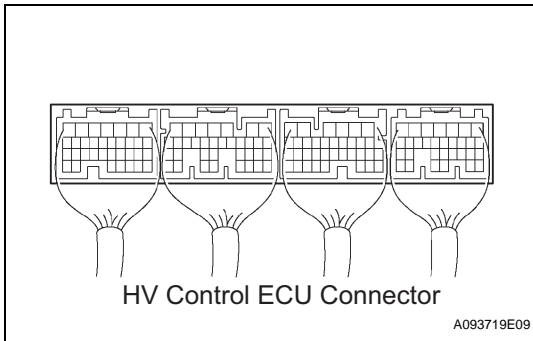

- (a) Check the connection condition of all the connectors at the HV control ECU.

OK:

Connectors have been connected securely and there is no poor connection.

NG CONNECT SECURELY

OK

3 CHECK CONNECTION CONDITION OF INVERTER CONNECTOR (LOOSENESS AND POOR CONTACT)

CAUTION:

Wear insulated gloves before performing the following operation.

- (a) Turn the power switch OFF.
- (b) Remove the service plug grip (see page [HB-154](#)).

NOTICE:

Turning the power switch ON (READY) with the service plug grip removed could cause malfunction. Therefore, never turn the power switch ON (READY) in this state.

- (c) Remove the inverter cover (see page [HV-531](#)).
- (d) Check the connection condition of the I9 and I10 inverter connectors.
- (e) Reinstall the inverter cover (see page [HV-538](#)).
- (f) Reinstall the service plug grip (see page [HB-154](#)).

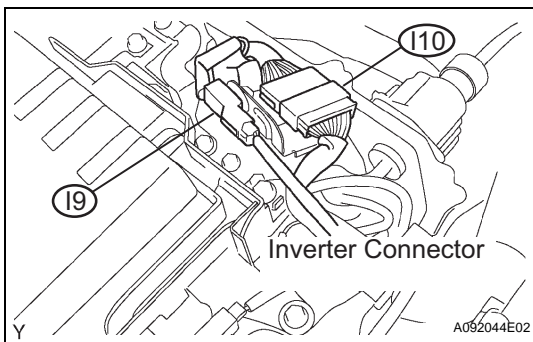

NG CONNECT SECURELY

OK

4 CONFIRM INFORMATION (EXCLUSIVE INFO 4)

- (a) Connect the intelligent tester to the DLC3.
- (b) Turn the power switch ON (IG).

HINT:

DTCs for the interlock switch system are output when turning the power switch ON (IG) with both service plug grip and inverter cover removed.

- (c) Turn the intelligent tester ON.

HV

- (d) Enter the following menus: DIAGNOSIS / OBD/MOBD / HV ECU / DTC INFO / CURRENT CODES.
- (e) Select DTC P0A94 to display its freeze frame data.
- (f) Select the item that has INF code 547, 548, or 549 from among INFORMATION 1 to 5, and press ENTER.
- (g) Read EXCLUSIVE INFO 4.

Result:

Displayed in Exclusive Information 4	Proceed to
-127 to -120, -95 to -88, -63 to -56, -31 to -24, 1 to 8, 33 to 40, 65 to 72, 97 to 104	A
-119 to -112, -87 to -80, -55 to -48, -23 to -16, 9 to 16, 41 to 48, 73 to 80, 105 to 112	B
-111 to -104, -79 to -72, -47 to -40, -15 to -8, 17 to 24, 49 to 56, 81 to 88, 113 to 120	C
-103 to -96, -71 to -64, -39 to -32, -7 to 0, 25 to 32, 57 to 64, 89 to 96, 121 to 127	D

B	REPLACE HYBRID VEHICLE CONTROL ECU
C	REPLACE INVERTER WITH CONVERTER ASSEMBLY
D	REPLACE HYBRID VEHICLE TRANSAXLE ASSEMBLY

A

5 READ OUTPUT DTC (HV ECU)

HV

- (a) Connect the intelligent tester to the DLC3.
- (b) Turn the power switch ON (IG).
HINT:
DTCs for the interlock switch system are output when turning the power switch ON (IG) with both service plug grip and inverter cover removed.
- (c) Turn the intelligent tester ON.
- (d) Enter the following menus: DIAGNOSIS / OBD/MOBD / HV ECU / DTC INFO / CURRENT CODES.
- (e) Read DTCs.

DTC No.	INF Code	Detection Item	See Page
P0A78	266	Drive Motor "A" Inverter Performance	HV-220
P0A94	558 or 560	DC / DC Converter Performance	HV-389
P0A94	588	DC / DC Converter Performance	HV-409
P0A94	589	DC / DC Converter Performance	HV-412
P0ADB	227	Hybrid Battery Positive Contactor Control Circuit Low	HV-439
P0ADF	229	Hybrid Battery Negative Contactor Control Circuit Low	HV-441
P3000	125	HV Battery Malfunction	HV-466
P3004	131	Power Cable Malfunction	HV-470

YES → **GO TO THE PAGE NUMBER SHOWN IN THE TABLE ABOVE**

NO

6 INSPECT HYBRID VEHICLE MOTOR ASSEMBLY

CAUTION:

Wear insulated gloves before performing the following operation.

- (a) Turn the power switch OFF.
- (b) Remove the service plug grip (see page [HB-154](#)).

NOTICE:

Turning the power switch ON (READY) with the service plug grip removed could cause malfunction. Therefore, never turn the power switch ON (READY) in this state.

- (c) Remove the inverter cover (see page [HV-531](#)).
- (d) Disconnect the three-phase alternating current cable for the hybrid vehicle motor from the inverter.
- (e) Using a milliohm meter, measure the resistance between the three-phase alternating current cable terminals of the hybrid vehicle motor.

NOTICE:

If the motor temperature is too high, the resistance varies considerably, which hinders determining malfunction. Therefore, measure the resistance at a minimum 8 hours after the vehicle has been stopped.

Standard resistance

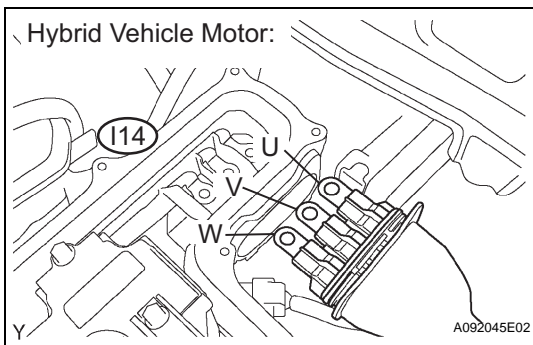

Tester Connection	Specified Condition*
U (I14-1) - V (I14-2)	Below 135 mΩ at 20°C
V (I14-2) - W (I14-3)	Below 135 mΩ at 20°C
W (I14-3) - U (I14-1)	Below 135 mΩ at 20°C

*: Apply the formula given below to correct the resistance.

$$R_{20} = R_t / \{1 + 0.00393 \times (T - 20)\}$$

R₂₀: Resistance converted to 20°C (mΩ)

R_t: Resistance between measured lines (mΩ)

T: Ambient air temperature during measurement (°C)

- (f) Calculate the difference between the maximum and minimum resistance between terminals U - V, V - W, and W - U.

Standard resistance:

Below 2 mΩ

- (g) Using a megohmmeter, measure the insulation resistance between the three-phase alternating current cable terminals of the hybrid vehicle motor and the body ground.

Standard resistance

Tester Connection	Specified Condition
U (I14-1) - Body ground	10 MΩ or higher
V (I14-2) - Body ground	10 MΩ or higher
W (I14-3) - Body ground	10 MΩ or higher

- (h) Reconnect the three-phase alternating current cable for the hybrid vehicle motor.

NG	REPLACE HYBRID VEHICLE MOTOR ASSEMBLY
-----------	--

OK

7	INSPECT HYBRID VEHICLE GENERATOR ASSEMBLY
----------	--

CAUTION:

Wear insulated gloves before performing the following operation.

- (a) Check that the service plug grip and inverter cover have been removed.
- (b) Disconnect the three-phase alternating current cable for the hybrid vehicle generator from the inverter.
- (c) Using a milliohm meter, measure the resistance between the three-phase alternating current cable terminals of the hybrid vehicle generator.

NOTICE:

If the generator temperature is too high, the resistance varies considerably, which hinders determining malfunction. Therefore, measure the resistance at a minimum 8 hours after the vehicle has been stopped.

Standard resistance

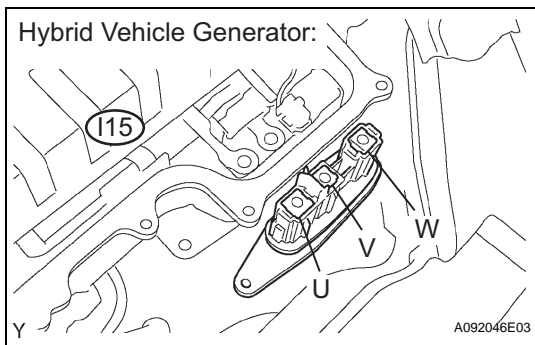

Tester Connection	Specified Condition*
U (I15-1) - V (I15-2)	Below 109 mΩ at 20°C
V (I15-2) - W (I15-3)	Below 109 mΩ at 20°C
W (I15-3) - U (I15-1)	Below 109 mΩ at 20°C

*: Apply the formula given below to correct the resistance.

$$R_{20} = R_t / \{1 + 0.00393 \times (T - 20)\}$$

R₂₀: Resistance converted to 20°C (mΩ)

R_t: Resistance between measured lines (mΩ)

T: Ambient air temperature during measurement (°C)

- (d) Calculate the difference between the maximum and minimum resistance between terminals U - V, V - W, and W - U.

Standard resistance:

Below 2 mΩ

- (e) Using a megohmmeter, measure the insulation resistance between the three-phase alternating current cable terminals of the hybrid vehicle generator and the body ground.

Standard resistance

Tester Connection	Specified Condition
U (I15-1) - Body ground	10 MΩ or higher
V (I15-2) - Body ground	10 MΩ or higher
W (I15-3) - Body ground	10 MΩ or higher

- (f) Reconnect the three-phase alternating current cable for the hybrid vehicle generator.

NG **REPLACE HYBRID VEHICLE GENERATOR ASSEMBLY**

OK

8 PERFORM ACTIVE TEST BY INTELLIGENT TESTER (INVERTER STOP)

CAUTION:

Wear insulated gloves before performing the following operation.

- (a) Check that the service plug grip and inverter cover have been removed.
- (b) Connect the intelligent tester to the DLC3.
- (c) Turn the power switch ON (IG).

HINT:

DTCs for the interlock switch system are output when turning the power switch ON (IG) with both service plug grip and inverter cover removed.

- (d) Turn the intelligent tester ON.
- (e) Enter the following menus: DIAGNOSIS / OBD/MOBD / HV ECU / ACTIVE TEST.
- (f) Measure the voltage between the terminals of the inverter connector while effecting INVERTER STOP.

Standard voltage

Tester Connection	Specified Condition
MUU (I10-9) - GINV (I10-16)	12 to 16 V
MVU (I10-10) - GINV (I10-16)	12 to 16 V
MWU (I10-11) - GINV (I10-16)	12 to 16 V
GUU (I10-4) - GINV (I10-16)	12 to 16 V
GVU (I10-5) - GINV (I10-16)	12 to 16 V
GWU (I10-6) - GINV (I10-16)	12 to 16 V

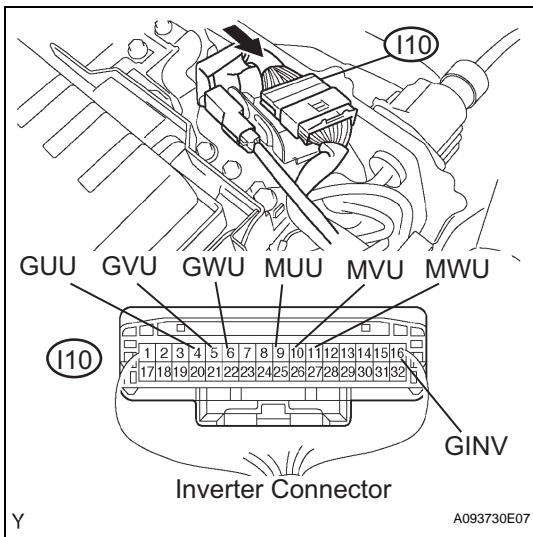

- (g) Turn the power switch OFF.

OK **REPLACE HYBRID VEHICLE CONTROL ECU AND INVERTER WITH CONVERTER ASSEMBLY**

NG

9 PERFORM ACTIVE TEST BY INTELLIGENT TESTER (INVERTER STOP)

CAUTION:

Wear insulated gloves before performing the following operation.

- (a) Check that the service plug grip and inverter cover have been removed.

HV

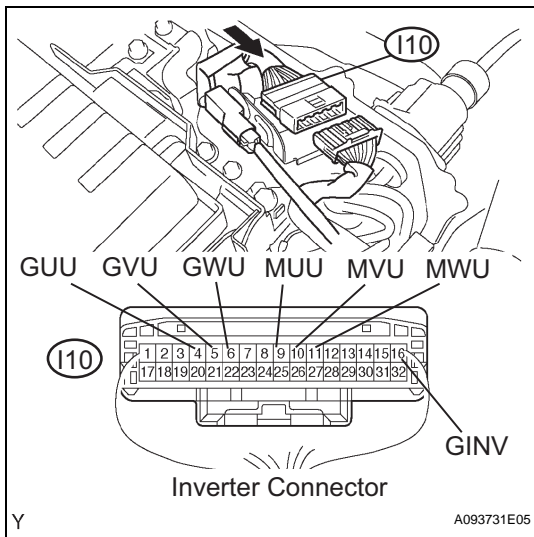

- (b) Disconnect the I10 inverter connector.
- (c) Connect the intelligent tester to the DLC3.
- (d) Turn the power switch ON (IG).
HINT:
DTCs for the interlock switch system are output when turning the power switch ON (IG) with both service plug grip and inverter cover removed.
- (e) Turn the intelligent tester ON.
- (f) Enter the following menus: DIAGNOSIS / OBD/MOBD / HV ECU / ACTIVE TEST.
- (g) Measure the voltage between the terminals of the inverter connector while effecting INVERTER STOP.

Standard voltage

Tester Connection	Specified Condition
MUU (I10-9) - GINV (I10-16)	14 to 16 V
MVU (I10-10) - GINV (I10-16)	14 to 16 V
MWU (I10-11) - GINV (I10-16)	14 to 16 V
GUU (I10-4) - GINV (I10-16)	14 to 16 V
GVU (I10-5) - GINV (I10-16)	14 to 16 V
GWU (I10-6) - GINV (I10-16)	14 to 16 V

- (h) Turn the power switch OFF.
- (i) Reconnect the inverter connector.
- (j) Reinstall the inverter cover (see page [HV-538](#)).
- (k) Reinstall the service plug grip (see page [HB-154](#)).

NG → **REPLACE INVERTER WITH CONVERTER ASSEMBLY**

OK

HV

REPLACE HYBRID VEHICLE CONTROL ECU

DTC	P0A94- 550	DC / DC Converter Performance
------------	-----------------------	--------------------------------------

DESCRIPTION

See the description of the boost converter (see page [HV-350](#)).

If the boost converter detects a circuit malfunction or over-voltage, the boost converter transmits that information to the OVL terminal of the HV control ECU via the boost converter over-voltage signal line.

DTC No.	INF Code	DTC Detection Condition	Trouble Area
P0A94	550	Boost converter over-voltage (OVL) signal detection (circuit malfunction)	<ul style="list-style-type: none"> • Wire harness or connector • Inverter with converter assembly

MONITOR DESCRIPTION

If the boost converter detects a circuit malfunction, it transmits a boost converter over-voltage signal to the HV control ECU. Upon receiving this signal, the HV control ECU illuminates the MIL and sets a DTC.

MONITOR STRATEGY

Related DTCs	P0A94 (INF 550): OVL detection circuit malfunction
Required sensor / components	Boost converter
Frequency of operation	Continuous
Duration	TOYOTA's intellectual property
MIL operation	Immediately
Sequence of operation	None

TYPICAL ENABLING CONDITIONS

The monitor will run whenever the following DTCs are not present	TOYOTA's intellectual property
Other conditions belong to TOYOTA's intellectual property	-

HV

TYPICAL MALFUNCTION THRESHOLDS

Boost converter	Circuit malfunction
-----------------	---------------------

COMPONENT OPERATING RANGE

Boost converter	DTC P0A94 (INF 550) is not detected
-----------------	-------------------------------------

WIRING DIAGRAM

Refer to DTC P0A78 (INF 282) (see page [HV-244](#)).

INSPECTION PROCEDURE

CAUTION:

- Before inspecting the high-voltage system, take safety precautions to prevent electrical shocks, such as wearing insulated gloves and removing the service plug grip. After removing the service plug grip, put it in your pocket to prevent other technicians from reconnecting it while you are servicing the high-voltage system.
- After disconnecting the service plug grip, wait for at least 5 minutes before touching any of the high-voltage connectors or terminals.

HINT:

At least 5 minutes are required to discharge the high-voltage condenser inside the inverter.

1 READ OUTPUT DTC (HV ECU)

- (a) Connect the intelligent tester to the DLC3.
- (b) Turn the power switch ON (IG).
- (c) Turn the intelligent tester ON.
- (d) Enter the following menus: DIAGNOSIS / OBD/MOBD / HV ECU / DTC INFO / CURRENT CODES.
- (e) Read DTCs.

Result:

DTC listed in the table below is output

DTC No.	INF Code Detection	Item	See Page
P0A94	545 or 546	DC / DC Converter Malfunction	HV-352

YES → **GO TO THE PAGE NUMBER SHOWN IN THE TABLE ABOVE**

NO

2 CHECK CONNECTION CONDITION OF INVERTER CONNECTOR (LOOSENESS AND POOR CONTACT)

CAUTION:

Wear insulated gloves before performing the following operation.

- (a) Turn the power switch OFF.
- (b) Remove the service plug grip (see page [HB-154](#)).

NOTICE:

Turning the power switch ON (READY) with the service plug grip removed could cause malfunction. Therefore, never turn the power switch ON (READY) in this state.

- (c) Remove the inverter cover (see page [HV-531](#)).
- (d) Check the connection condition of the I9 and I10 inverter connectors.

OK:

Connectors have been connected securely and there is no poor connection.

- (e) Reinstall the inverter cover (see page [HV-538](#)).
- (f) Reinstall the service plug grip (see page [HB-154](#)).

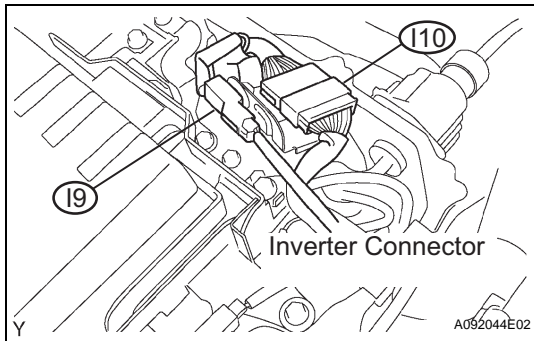

NG → **CONNECT SECURELY**

OK

3 READ OUTPUT DTC (HV ECU)

- (a) Connect the intelligent tester to the DLC3.
- (b) Turn the power switch ON (IG).

HV

HINT:

DTCs for the interlock switch system are output when turning the power switch ON (IG) with both service plug grip and inverter cover removed.

- (c) Turn the intelligent tester ON.
- (d) Enter the following menus: DIAGNOSIS / OBD/MOBD / HV ECU / DTC INFO / CURRENT CODES.
- (e) Read DTCs.

Result:

DTCs P0A78 (INF 282, 286) and P0A7A (INF 324) (inverter circuit malfunction) are output

NO → **REPLACE INVERTER WITH CONVERTER ASSEMBLY**

YES

4 CHECK INVERTER WITH CONVERTER ASSEMBLY (IGCT VOLTAGE)

CAUTION:

Wear insulated gloves before performing the following operation.

- (a) Turn the power switch OFF.
- (b) Remove the service plug grip (see page [HB-154](#)).

NOTICE:

Turning the power switch ON (READY) with the service plug grip removed could cause malfunction. Therefore, never turn the power switch ON (READY) in this state.

- (c) Remove the inverter cover (see page [HV-531](#)).
- (d) Turn the power switch ON (IG).

HINT:

DTCs for the interlock switch system are output when turning the power switch ON (IG) with both service plug grip and inverter cover removed.

- (e) Measure the voltage between the terminals of the inverter connector.

Standard voltage

Tester Connection	Specified Condition
IGCT (I9-1) - GND1 (I9-2)	8 V or more

- (f) Turn the power switch OFF.
- (g) Reinstall the inverter cover (see page [HV-538](#)).
- (h) Reinstall the service plug grip (see page [HB-154](#)).

NG → **REPAIR OR REPLACE HARNESS OR CONNECTOR**

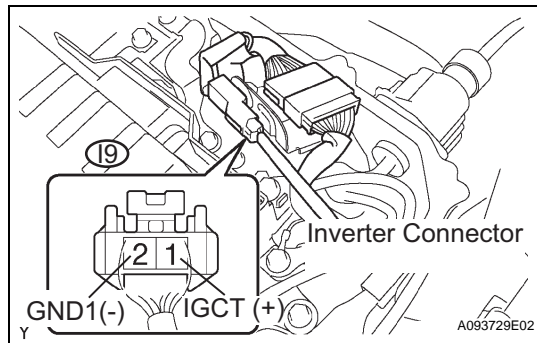

OK

REPLACE INVERTER WITH CONVERTER ASSEMBLY

DTC	P0A94-551	DC / DC Converter Performance
------------	------------------	--------------------------------------

DTC	P0A94-552	DC / DC Converter Performance
------------	------------------	--------------------------------------

DESCRIPTION

See the description of the boost converter (see page [HV-350](#)).

If the boost converter has a circuit malfunction, or internal short, or overheats, the boost converter transmits this information to the FCV terminal of the HV control ECU via the boost converter fail signal line.

The HV control ECU monitors the boost converter fail signal line and detects a malfunction.

DTC No.	INF Code	DTC Detection Condition	Trouble Area
P0A94	551	Open or GND short in boost converter fail (FCV) signal circuit	<ul style="list-style-type: none"> Wire harness or connector Inverter with converter assembly
P0A94	552	+B short in boost converter fail (FCV) signal circuit	<ul style="list-style-type: none"> Wire harness or connector Inverter with converter assembly

MONITOR DESCRIPTION

The HV control ECU monitors the boost converter fail (FCV) signal line. If the HV control ECU detects an open or short malfunction of the FCV signal circuit, the HV control ECU illuminates the MIL and sets a DTC.

MONITOR STRATEGY

Related DTCs	P0A94 (INF 551 / 552): Boost converter / Converter Finv detection
Required sensor / components	Boost converter
Frequency of operation	Continuous
Duration	TOYOTA's intellectual property
MIL operation	1 driving cycle
Sequence of operation	None

TYPICAL ENABLING CONDITIONS

The monitor will run whenever the following DTCs are not present	TOYOTA's intellectual property
Other conditions belong to TOYOTA's intellectual property	-

TYPICAL MALFUNCTION THRESHOLDS

Boost converter fail signal circuit	Open or short
-------------------------------------	---------------

COMPONENT OPERATING RANGE

Boost converter	DTC P0A94 (INF 551 / 552) is not detected
-----------------	---

WIRING DIAGRAM

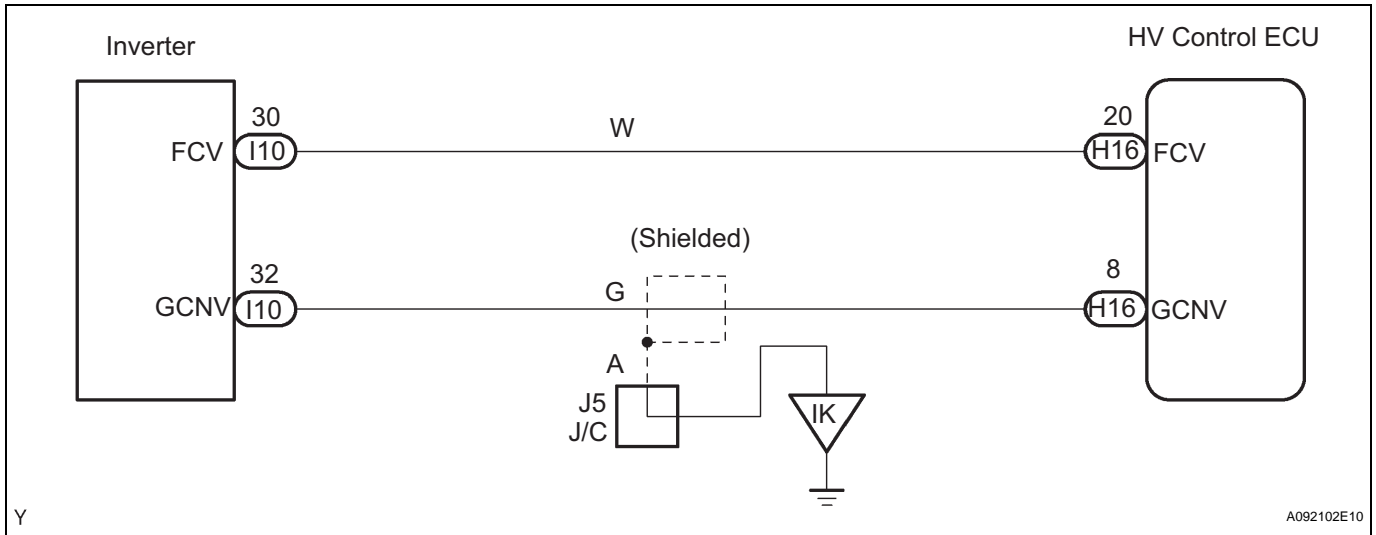

INSPECTION PROCEDURE

CAUTION:

- Before inspecting the high-voltage system, take safety precautions to prevent electrical shocks, such as wearing insulated gloves and removing the service plug grip. After removing the service plug grip, put it in your pocket to prevent other technicians from reconnecting it while you are servicing the high-voltage system.
- After disconnecting the service plug grip, wait for at least 5 minutes before touching any of the high-voltage connectors or terminals.

HINT:

HINT: At least 5 minutes are required to discharge the high-voltage condenser inside the inverter.

1 CHECK HARNESS AND CONNECTOR (HYBRID VEHICLE CONTROL ECU - INVERTER)

HV

CAUTION:

Wear insulated gloves before performing the following operation.

- Turn the power switch OFF.
- Remove the service plug grip (see page [HB-154](#)).

NOTICE:

Turning the power switch ON (READY) with the service plug grip removed could cause malfunction. Therefore, never turn the power switch ON (READY) in this state.

- Disconnect the H16 HV control ECU connector.
- Remove the inverter cover (see page [HV-531](#)).

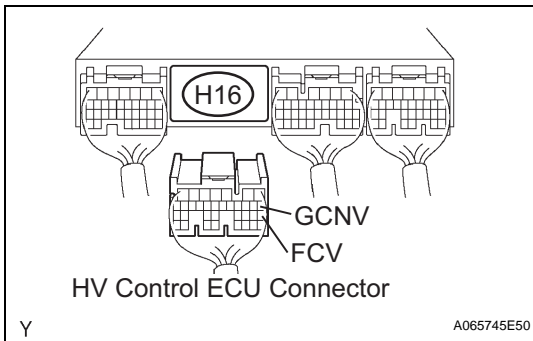

Y

A065745E50

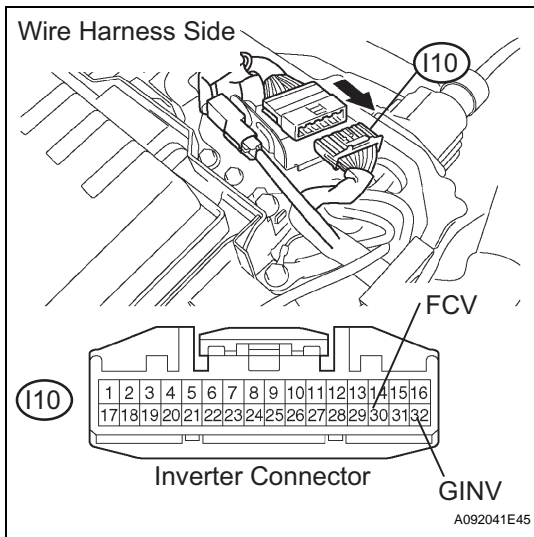

- (e) Disconnect the I10 inverter connector.
- (f) Turn the power switch ON (IG).
HINT:
DTCs for the interlock switch system are output when turning the power switch ON (IG) with both service plug grip and inverter cover removed.
- (g) Measure the voltage between the terminals of the HV control ECU connector and body ground.

Standard voltage

Tester Connection	Specified Condition
FCV (H16-20) - Body ground	Below 1 V
GCVN (H16-8) - Body ground	Below 1 V

- (h) Turn the power switch OFF.
- (i) Measure the resistance between the wire harness side connectors.

Standard resistance (Check for open)

Tester Connection	Specified Condition
FCV (H16-20) - FCV (I10-30)	Below 1 Ω
GCVN (H16-8) - GCVN (I10-32)	Below 1 Ω

Standard resistance (Check for short)

Tester Connection	Specified Condition
FCV (H16-20) or FCV (I10-30) - Body ground	10 kΩ or higher
GCVN (H16-8) or GCVN (I10-32) - Body ground	10 kΩ or higher

- (j) Reconnect the inverter connector.
- (k) Reconnect the HV control ECU connector.
- (l) Reinstall the inverter cover (see page HV-538).
- (m) Reinstall the service plug grip (see page HB-154).

NG

REPAIR OR REPLACE HARNESS OR CONNECTOR

OK

REPLACE INVERTER WITH CONVERTER ASSEMBLY

HV

DTC	P0A94- 553	DC / DC Converter Performance
------------	-----------------------	--------------------------------------

DESCRIPTION

See the description of the boost converter (see page [HV-350](#)).

If the boost converter has a circuit malfunction, internal short, or overheats, the boost converter transmits that information to the FCV terminal of the HV control ECU via the boost converter fail signal line.

DTC No.	INF Code	DTC Detection Condition	Trouble Area
P0A94	553	Boost converter fail (FCV) signal detection (boost converter overheating)	<ul style="list-style-type: none"> • Wire harness or connector • Inverter cooling system • Water pump with motor assembly • Cooling fan motor • No. 2 cooling fan motor • HV transaxle assembly • Hybrid vehicle motor • Hybrid vehicle generator • HV control ECU • Inverter with converter assembly

MONITOR DESCRIPTION

If the boost converter is overheated, it transmits a boost converter fail signal to the HV control ECU. Upon receiving this signal, the HV control ECU illuminates the MIL and sets a DTC.

MONITOR STRATEGY

Related DTCs	P0A94 (INF 553): FCV detection over heat
Required sensor / components	Boost converter
Frequency of operation	Continuous
Duration	TOYOTA's intellectual property
MIL operation	Immediately
Sequence of operation	None

HV

TYPICAL ENABLING CONDITIONS

The monitor will run whenever the following DTCs are not present	TOYOTA's intellectual property
Other conditions belong to TOYOTA's intellectual property	-

TYPICAL MALFUNCTION THRESHOLDS

Boost converter	Overheated
-----------------	------------

COMPONENT OPERATING RANGE

Boost converter	DTC P0A94 (INF 553) is not detected
-----------------	-------------------------------------

WIRING DIAGRAM

Refer to DTC P0A78 (INF 279) (see page [HV-235](#)).

INSPECTION PROCEDURE

CAUTION:

- Before inspecting the high-voltage system, take safety precautions to prevent electrical shocks, such as wearing insulated gloves and removing the service plug grip. After removing the service plug grip, put it in your pocket to prevent other technicians from reconnecting it while you are servicing the high-voltage system.
- After disconnecting the service plug grip, wait for at least 5 minutes before touching any of the high-voltage connectors or terminals.

HINT:

At least 5 minutes are required to discharge the high-voltage condenser inside the inverter.

1	READ OUTPUT DTC (HV ECU)
----------	---------------------------------

- (a) Connect the intelligent tester to the DLC3.
- (b) Turn the power switch ON (IG).
- (c) Turn the intelligent tester ON.
- (d) Enter the following menus: DIAGNOSIS / OBD/MOBD / HV ECU / DTC INFO / CURRENT CODES.
- (e) Read DTCs.

Result:

DTCs listed in the table below are output

DTC No.	Relevant Diagnosis
P0A1D	Hybrid Powertrain Control Module
P0A2B, P0A2C or P0A2D	Drive Motor "A" Temperature Sensor Circuit System
P0A37, P0A38 or P0A39	Generator Temperature Sensor Circuit System
P0A3F, P0A40 or P0A4	Drive Motor "A" Position Sensor Circuit System
P0A4B, P0A4C or P0A4D	Generator Position Sensor Circuit System
P0A60 or P0A63	Drive Motor "A" Current Sensor Circuit System
P0A72 or P0A75	Generator Current Sensor Circuit System
P0A78	Drive Motor "A" Inverter Performance
P0A7A	Generator Inverter Performance
P0A90	Drive Motor "A" Performance
P0A92	Hybrid Generator Performance
P0A93	Inverter Cooling System Malfunction
P0A94	DC / DC Converter Malfunction
P0AA1, P0AA4, P0AE0, P0AE6, P0AE7, P0ADB or P0ADF	System Main Relay Circuit System
P0AA6, P3004	High Voltage System
P0AEE	Motor Inverter Temperature Sensor Malfunction
P3000	HV Battery System Malfunction
P3110	Integration Relay Malfunction
P3221	Generator Inverter Temperature Sensor Circuit System
P3226	DC / DC Boost Converter Temperature Sensor Circuit System

HV

YES

GO TO DTC CHART. FIND PAGE NUMBER TO PROCEED TO DIAGNOSTIC TROUBLESHOOTING FLOWCHART

NO

2 CHECK QUANTITY OF HV COOLANT

- (a) Check that there is a sufficient amount of coolant for the inverter.

OK:

There is a sufficient amount of coolant for the inverter

NG

ADD HV COOLANT

OK

3 CHECK COOLANT HOSE

- (a) Check that the hoses of the cooling system are not bent or clogged (refer to the cooling system [see page [HV-346](#)]).

OK:

The hoses of the cooling system are not bent or clogged

NG

CORRECT TO NORMAL CONDITION

OK

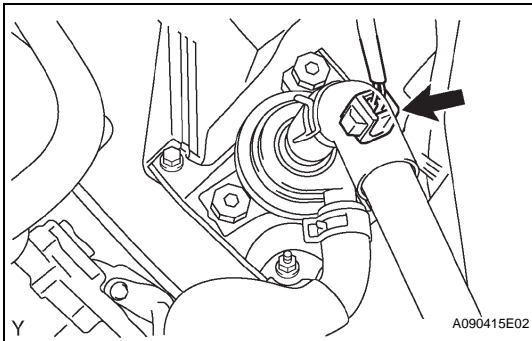
4 CHECK CONNECTION CONDITION OF WATER PUMP CONNECTOR (LOOSENESS AND POOR CONTACT)

- (a) Check the connection condition of the water pump connector.

OK:

Connector has been connected securely and there is no poor connection.

NG

CONNECT SECURELY

OK

5 CHECK WATER PUMP WITH MOTOR ASSEMBLY

- (a) Turn the power switch ON (IG).
 (b) Check the operation of the water pump.

OK:

Coolant is sloshing in the reservoir tank

NG

REPLACE WATER PUMP WITH MOTOR ASSEMBLY

HV

OK

6 CHECK CONNECTION CONDITION OF COOLING FAN MOTOR CONNECTOR (LOOSENESS AND POOR CONTACT)

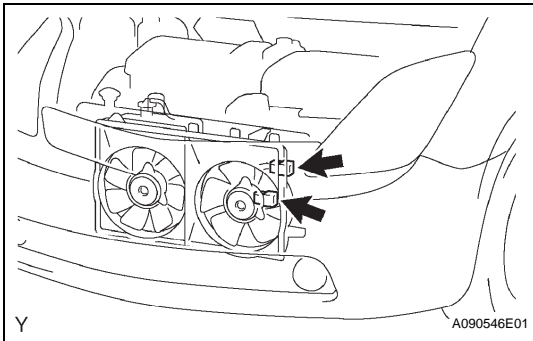

(a) Check the connection condition of the cooling fan motor connectors.

OK:

Connectors have been connected securely and there is no poor connection.

NG **CONNECT SECURELY**

OK

7 INSPECT COOLING FAN MOTOR

(a) Inspect the cooling fan motor (see page [CO-5](#)).

NG **REPLACE COOLING FAN MOTOR AND ADD ENGINE COOLANT**

OK

8 INSPECT NO. 2 COOLING FAN MOTOR

(a) Inspect the No. 2 cooling fan motor (see page [CO-5](#)).

NG **REPLACE NO. 2 COOLING FAN MOTOR AND ADD ENGINE COOLANT**

OK

9 CHECK CONNECTION CONDITION OF HYBRID VEHICLE CONTROL ECU CONNECTOR (LOOSENESS AND POOR CONTACT)

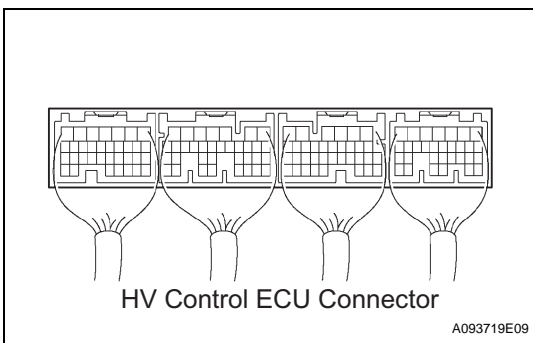

(a) Check the connection condition of all the connectors at the HV control ECU.

OK:

Connectors have been connected securely and there is no poor connection.

NG **CONNECT SECURELY**

OK

HV

10 CHECK CONNECTION CONDITION OF INVERTER CONNECTOR (LOOSENESS AND POOR CONTACT)

CAUTION:

Wear insulated gloves before performing the following operation.

- (a) Turn the power switch OFF.
- (b) Remove the service plug grip (see page HB-154).

NOTICE:

Turning the power switch ON (READY) with the service plug grip removed could cause malfunction. Therefore, never turn the power switch ON (READY) in this state.

- (c) Remove the inverter cover (see page HV-531).
- (d) Check the connection condition of the I9 and I10 inverter connectors.

OK:

Connectors have been connected securely and there is no poor connection.

- (e) Reinstall the inverter cover (see page HV-538).
- (f) Reinstall the service plug grip (see page HB-154).

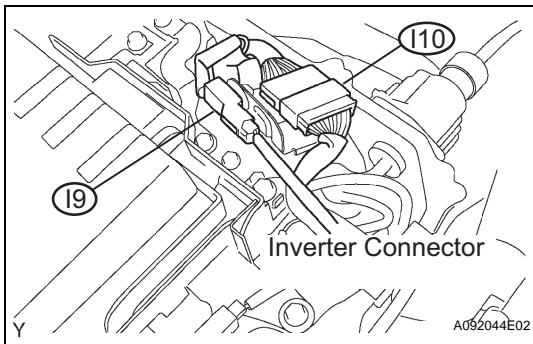

NG **CONNECT SECURELY**

OK

11 CONFIRM INFORMATION (EXCLUSIVE INFO 4)

HV

- (a) Connect the intelligent tester to the DLC3.
- (b) Turn the power switch ON (IG).
HINT:
DTCs for the interlock switch system are output when turning the power switch ON (IG) with both service plug grip and inverter cover removed.
- (c) Turn the intelligent tester ON.
- (d) Enter the following menus: DIAGNOSIS / OBD/MOBD / HV ECU / DTC INFO / CURRENT CODES.
- (e) Select DTC P0A94 to display its freeze frame data.
- (f) Select the item that has INF code 553 from among INFORMATION 1 to 5, and press ENTER.
- (g) Read EXCLUSIVE INFO 4.

Result:

Displayed in Exclusive Information 4	Proceed to
-127 to -120, -95 to -88, -63 to -56, -31 to -24, 1 to 8, 33 to 40, 65 to 72, 97 to 104	A
-119 to -112, -87 to -80, -55 to -48, -23 to -16, 9 to 16, 41 to 48, 73 to 80, 105 to 112	B
-111 to -104, -79 to -72, -47 to -40, -15 to -8, 17 to 24, 49 to 56, 81 to 88, 113 to 120	C
-103 to -96, -71 to -64, -39 to -32, -7 to 0, 25 to 32, 57 to 64, 89 to 96, 121 to 127	D

- B** REPLACE HYBRID VEHICLE CONTROL ECU
- C** REPLACE INVERTER WITH CONVERTER ASSEMBLY
- D** REPLACE HYBRID VEHICLE TRANSAXLE ASSEMBLY

A

12 INSPECT HYBRID VEHICLE MOTOR ASSEMBLY

CAUTION:

Wear insulated gloves before performing the following operation.

- (a) Turn the power switch OFF.
- (b) Remove the service plug grip (see page [HB-154](#)).

NOTICE:

Turning the power switch ON (READY) with the service plug grip removed could cause malfunction. Therefore, never turn the power switch ON (READY) in this state.

- (c) Remove the inverter cover (see page [HV-531](#)).
- (d) Disconnect the three-phase alternating current cable for the hybrid vehicle motor from the inverter.
- (e) Using a milliohm meter, measure the resistance between the three-phase alternating current cable terminals of the hybrid vehicle motor.

NOTICE:

If the motor temperature is too high, the resistance varies considerably, which hinders determining malfunction. Therefore, measure the resistance at a minimum 8 hours after the vehicle has been stopped.

Standard resistance

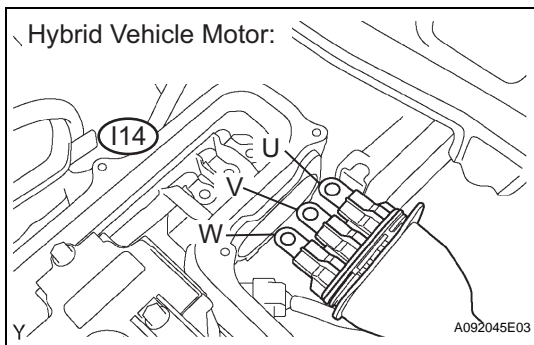

Tester Connection	Specified Condition*
U (I14-1) - V (I14-2)	Below 135 mΩ at 20°C
V (I14-2) - W (I14-3)	Below 135 mΩ at 20°C
W (I14-3) - U (I14-1)	Below 135 mΩ at 20°C

*: Apply the formula given below to correct the resistance.

$$R_{20} = R_t / \{1 + 0.00393 \times (T - 20)\}$$

R₂₀: Resistance converted to 20°C (mΩ)

R_t: Resistance between measured lines (mΩ)

T: Ambient air temperature during measurement (°C)

- (f) Calculate the difference between the maximum and minimum resistance between terminals U - V, V - W, and W - U.

Standard resistance:

Below 2 mΩ

- (g) Using a megohmmeter, measure the insulation resistance between the three-phase alternating current cable terminals of the hybrid vehicle motor and the body ground.

Standard resistance

Tester Connection	Specified Condition
U (I14-1) - Body ground	10 MΩ or higher
V (I14-2) - Body ground	10 MΩ or higher
W (I14-3) - Body ground	10 MΩ or higher

- (h) Reconnect the three-phase alternating current cable for the hybrid vehicle motor.

NG	REPLACE HYBRID VEHICLE MOTOR ASSEMBLY
-----------	--

OK

13	INSPECT HYBRID VEHICLE GENERATOR ASSEMBLY
-----------	--

CAUTION:

Wear insulated gloves before performing the following operation.

- (a) Check that the service plug grip and inverter cover have been removed.
- (b) Disconnect the three-phase alternating current cable for the hybrid vehicle generator from the inverter.
- (c) Using a milliohm meter, measure the resistance between the three-phase alternating current cable terminals of the hybrid vehicle generator.

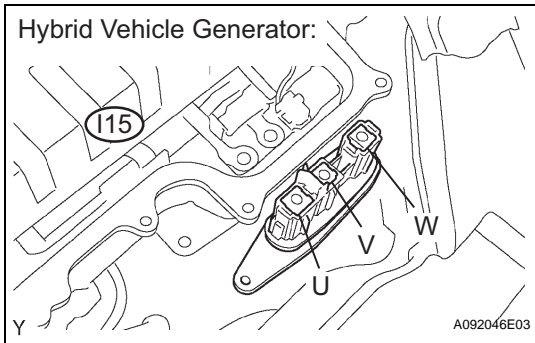

NOTICE:

If the generator temperature is too high, the resistance varies considerably, which hinders determining malfunction. Therefore, measure the resistance at a minimum 8 hours after the vehicle has been stopped.

Standard resistance

Tester Connection	Specified Condition*
U (I15-1) - V (I15-2)	Below 109 mΩ at 20°C
V (I15-2) - W (I15-3)	Below 109 mΩ at 20°C
W (I15-3) - U (I15-1)	Below 109 mΩ at 20°C

*: Apply the formula given below to correct the resistance.

$$R_{20} = R_t / \{1 + 0.00393 \times (T - 20)\}$$

R₂₀: Resistance converted to 20°C (mΩ)

R_t: Resistance between measured lines (mΩ)

T: Ambient air temperature during measurement (°C)

- (d) Calculate the difference between the maximum and minimum resistance between terminals U - V, V - W, and W - U.

Standard resistance:

Below 2 Ω

- (e) Using a megohmmeter, measure the insulation resistance between the three-phase alternating current cable terminals of the hybrid vehicle generator and the body ground.

Standard resistance

Tester Connection	Specified Condition
U (I15-1) - Body ground	10 MΩ or higher
V (I15-2) - Body ground	10 MΩ or higher
W (I15-3) - Body ground	10 MΩ or higher

- (f) Reconnect the three-phase alternating current cable for the hybrid vehicle generator.

NG → **REPLACE INVERTER WITH CONVERTER ASSEMBLY**

OK

14 **PERFORM ACTIVE TEST BY INTELLIGENT TESTER (INVERTER STOP)**

CAUTION:

Wear insulated gloves before performing the following operation.

- (a) Check that the service plug grip and inverter cover have been removed.
- (b) Connect the intelligent tester to the DLC3.
- (c) Turn the power switch ON (IG).

HINT:

DTCs for the interlock switch system are output when turning the power switch ON (IG) with both service plug grip and inverter cover removed.

- (d) Turn the intelligent tester ON.
- (e) Enter the following menus: DIAGNOSIS / OBD/MOBD / HV ECU / ACTIVE TEST.
- (f) Measure the voltage between the terminals of the inverter connector while effecting INVERTER STOP.

Standard voltage

Tester Connection	Specified Condition
MUU (I10-9) - GINV (I10-16)	12 to 16 V
MVU (I10-10) - GINV (I10-16)	12 to 16 V
MWU (I10-11) - GINV (I10-16)	12 to 16 V
GUU (I10-4) - GINV (I10-16)	12 to 16 V
GVU (I10-5) - GINV (I10-16)	12 to 16 V
GWU (I10-6) - GINV (I10-16)	12 to 16 V

- (g) Turn the power switch OFF.

OK → **REPLACE INVERTER WITH CONVERTER ASSEMBLY**

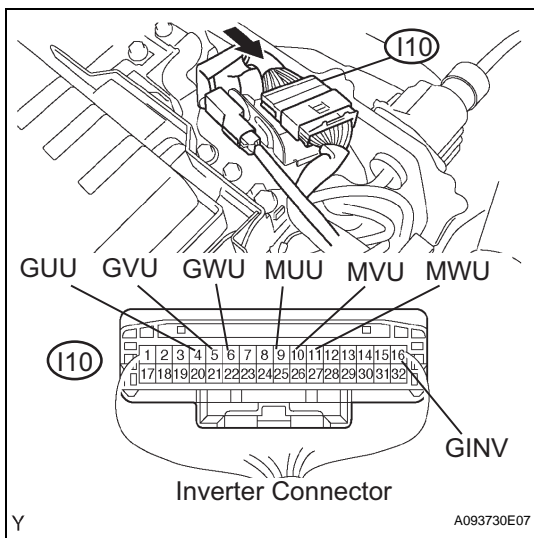

NG

HV

15 PERFORM ACTIVE TEST BY INTELLIGENT TESTER (INVERTER STOP)

CAUTION:

Wear insulated gloves before performing the following operation.

- (a) Check that the service plug grip and inverter cover have been removed.
- (b) Disconnect the I10 inverter connector.
- (c) Connect the intelligent tester to the DLC3.
- (d) Turn the power switch ON (IG).

HINT:

DTCs for the interlock switch system are output when turning the power switch ON (IG) with both service plug grip and inverter cover removed.

- (e) Turn the intelligent tester ON.
- (f) Enter the following menus: DIAGNOSIS / OBD/MOBD / HV ECU / ACTIVE TEST.
- (g) Measure the voltage between the terminals of the inverter connector while effecting INVERTER STOP.

Standard voltage

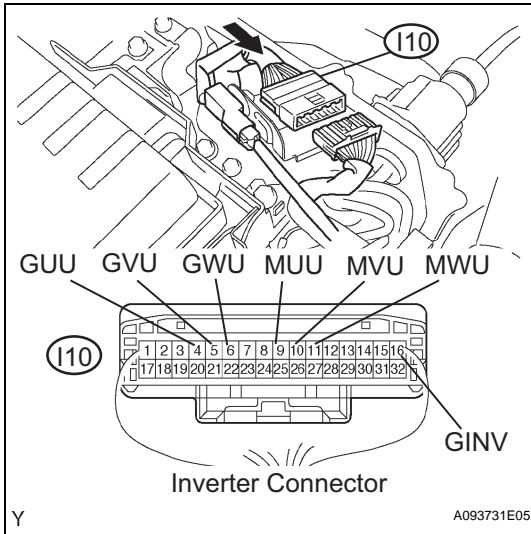

Tester Connection	Specified Condition
MUU (I10-9) - GINV (I10-16)	14 to 16 V
MVU (I10-10) - GINV (I10-16)	14 to 16 V
MWU (I10-11) - GINV (I10-16)	14 to 16 V
GUU (I10-4) - GINV (I10-16)	14 to 16 V
GVU (I10-5) - GINV (I10-16)	14 to 16 V
GWU (I10-6) - GINV (I10-16)	14 to 16 V

- (h) Turn the power switch OFF.
- (i) Reconnect the inverter connector.
- (j) Reinstall the inverter cover (see page HV-538).
- (k) Reinstall the service plug grip (see page HB-154).

OK

NG **REPLACE INVERTER WITH CONVERTER ASSEMBLY**

REPLACE HYBRID VEHICLE CONTROL ECU

HV

DTC	P0A94-554	DC / DC Converter Performance
DTC	P0A94-555	DC / DC Converter Performance
DTC	P0A94-556	DC / DC Converter Performance

DESCRIPTION

See the description of the boost converter (see page [HV-350](#)).

If the boost converter has a circuit malfunction, internal short, or overheats, the boost converter transmits that information to the FCV terminal of the HV control ECU via the boost converter fail signal line.

DTC No.	INF Code	DTC Detection Condition	Trouble Area
P0A94	554	Boost converter fail (FCV) signal detection (over current by HV control ECU malfunction)	<ul style="list-style-type: none"> • Wire harness or connector • HV transaxle assembly • Hybrid vehicle motor • Hybrid vehicle generator • HV control ECU • Inverter with converter assembly
P0A94	555	Boost converter fail (FCV) signal detection (over current by inverter assembly malfunction)	<ul style="list-style-type: none"> • Wire harness or connector • HV transaxle assembly • Hybrid vehicle motor • Hybrid vehicle generator • HV control ECU • Inverter with converter assembly
P0A94	556	Boost converter fail (FCV) signal detection (over current by HV transaxle assembly malfunction)	<ul style="list-style-type: none"> • Wire harness or connector • HV transaxle assembly • Hybrid vehicle motor • Hybrid vehicle generator • HV control ECU • Inverter with converter assembly

MONITOR DESCRIPTION

If over-amperage flows through the boost converter due to an internal short, the boost converter transmits a boost converter fail signal to the HV control ECU. Upon receiving this signal, the HV control ECU illuminates the MIL and sets a DTC.

MONITOR STRATEGY

Related DTCs	P0A94 (INF 554 / 555 / 556): FCV detection over current
Required sensor / components	Boost converter
Frequency of operation	Continuous
Duration	TOYOTA's intellectual property
MIL operation	Immediately
Sequence of operation	None

TYPICAL ENABLING CONDITIONS

The monitor will run whenever the following DTCs are not present	TOYOTA's intellectual property
--	--------------------------------

Other conditions belong to TOYOTA's intellectual property	-
---	---

TYPICAL MALFUNCTION THRESHOLDS

Boost converter	Over current (internal short)
-----------------	-------------------------------

COMPONENT OPERATING RANGE

Boost converter	DTC P0A94 (INF 554 / 555 / 556) is not detected
-----------------	---

WIRING DIAGRAM

Refer to DTC P0A78 (INF 279) (see page [HV-235](#)).

INSPECTION PROCEDURE

CAUTION:

- Before inspecting the high-voltage system, take safety precautions to prevent electrical shocks, such as wearing insulated gloves and removing the service plug grip. After removing the service plug grip, put it in your pocket to prevent other technicians from reconnecting it while you are servicing the high-voltage system.
- After disconnecting the service plug grip, wait for at least 5 minutes before touching any of the high-voltage connectors or terminals.

HINT:

At least 5 minutes are required to discharge the high-voltage condenser inside the inverter.

1	READ OUTPUT DTC (HV ECU)
----------	---------------------------------

- Connect the intelligent tester to the DLC3.
- Turn the power switch ON (IG).
- Turn the intelligent tester ON.
- Enter the following menus: DIAGNOSIS / OBD/MOBD / HV ECU / DTC INFO / CURRENT CODES.
- Read DTCs.

Result:

DTCs listed in the table below are output

DTC No.	Relevant Diagnosis
P0A1D	Hybrid Powertrain Control Module
P0A2B, P0A2C or P0A2D	Drive Motor "A" Temperature Sensor Circuit System
P0A37, P0A38 or P0A39	Generator Temperature Sensor Circuit System
P0A3F, P0A40 or P0A4	Drive Motor "A" Position Sensor Circuit System
P0A4B, P0A4C or P0A4D	Generator Position Sensor Circuit System
P0A60 or P0A63	Drive Motor "A" Current Sensor Circuit System
P0A72 or P0A75	Generator Current Sensor Circuit System
P0A78	Drive Motor "A" Inverter Performance
P0A7A	Generator Inverter Performance
P0A90	Drive Motor "A" Performance
P0A92	Hybrid Generator Performance
P0A93	Inverter Cooling System Malfunction
P0A94	DC / DC Converter Malfunction
P0AA1, P0AA4, P0AE0, P0AE6, P0AE7, P0ADB or P0ADF	System Main Relay Circuit System
P0AA6, P3004	High Voltage System
P0AEE	Motor Inverter Temperature Sensor Malfunction

DTC No.	Relevant Diagnosis
P3000	HV Battery System Malfunction
P3110	Integration Relay Malfunction
P3221	Generator Inverter Temperature Sensor Circuit System
P3226	DC / DC Boost Converter Temperature Sensor Circuit System

YES → **GO TO DTC CHART. FIND PAGE NUMBER TO PROCEED TO DIAGNOSTIC TROUBLESHOOTING FLOWCHART.**

NO

2 CHECK CONNECTION CONDITION OF HYBRID VEHICLE CONTROL ECU CONNECTOR (LOOSENESS AND POOR CONTACT)

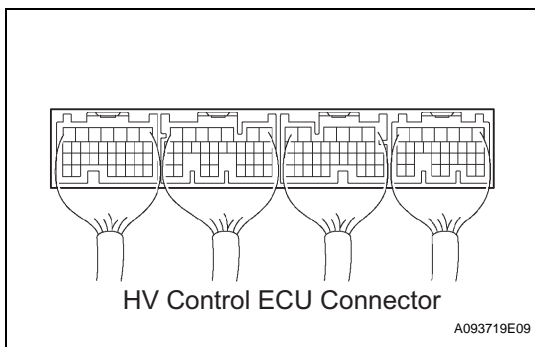

(a) Check the connection condition of all the connectors at the HV control ECU.

OK:

Connectors have been connected securely and there is no poor connection.

NG → **CONNECT SECURELY**

OK

3 CHECK CONNECTION CONDITION OF INVERTER CONNECTOR (LOOSENESS AND POOR CONTACT)

HV

CAUTION:

Wear insulated gloves before performing the following operation.

- (a) Turn the power switch OFF.
- (b) Remove the service plug grip (see page [HB-154](#)).

NOTICE:

Turning the power switch ON (READY) with the service plug grip removed could cause malfunction. Therefore, never turn the power switch ON (READY) in this state.

- (c) Remove the inverter cover (see page [HV-531](#)).
- (d) Check the connection condition of the I9 and I10 inverter connectors.

OK:

Connectors have been connected securely and there is no poor connection.

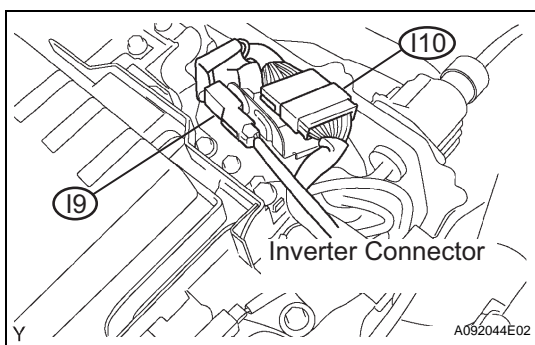

NG → **CONNECT SECURELY**

OK

4 CONFIRM INFORMATION (EXCLUSIVE INFO 4)

- (a) Connect the intelligent tester to the DLC3.
- (b) Turn the power switch ON (IG).
HINT:
DTCs for the interlock switch system are output when turning the power switch ON (IG) with both service plug grip and inverter cover removed.
- (c) Turn the intelligent tester ON.
- (d) Enter the following menus: DIAGNOSIS / OBD/MOBD / HV ECU / DTC INFO / CURRENT CODES.
- (e) Select DTC P0A94 to display its freeze frame data.
- (f) Select the item that has INF code 554, 555, or 556 from among INFORMATION 1 to 5, and press ENTER.
- (g) Read EXCLUSIVE INFO 4.

Result:

Displayed in Exclusive Information 4	Proceed to
-127 to -120, -95 to -88, -63 to -56, -31 to -24, 1 to 8, 33 to 40, 65 to 72, 97 to 104	A
-119 to -112, -87 to -80, -55 to -48, -23 to -16, 9 to 16, 41 to 48, 73 to 80, 105 to 112	B
-111 to -104, -79 to -72, -47 to -40, -15 to -8, 17 to 24, 49 to 56, 81 to 88, 113 to 120	C
-103 to -96, -71 to -64, -39 to -32, -7 to 0, 25 to 32, 57 to 64, 89 to 96, 121 to 127	D

B	REPLACE HYBRID VEHICLE CONTROL ECU
C	REPLACE INVERTER WITH CONVERTER ASSEMBLY
D	REPLACE HYBRID VEHICLE TRANSAXLE ASSEMBLY

HV

A

5 INSPECT HYBRID VEHICLE MOTOR ASSEMBLY

CAUTION:

Wear insulated gloves before performing the following operation.

- (a) Turn the power switch OFF.
- (b) Remove the service plug grip (see page [HB-154](#)).

NOTICE:

Turning the power switch ON (READY) with the service plug grip removed could cause malfunction. Therefore, never turn the power switch ON (READY) in this state.

- (c) Remove the inverter cover (see page [HV-531](#)).

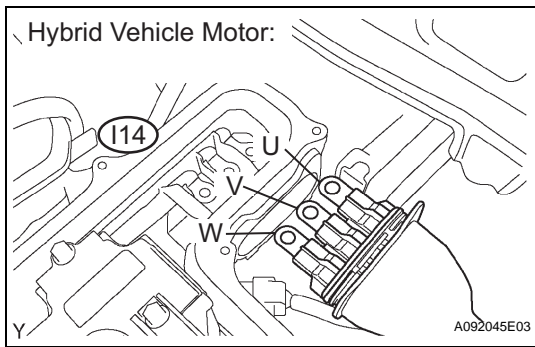

- (d) Disconnect the three-phase alternating current cable for the hybrid vehicle motor from the inverter.
- (e) Using a milliohm meter, measure the resistance between the three-phase alternating current cable terminals of the hybrid vehicle motor.

NOTICE:

If the motor temperature is too high, the resistance varies considerably, which hinders determining malfunction. Therefore, measure the resistance at a minimum 8 hours after the vehicle has been stopped.

Standard resistance

Tester Connection	Specified Condition*
U (I14-1) - V (I14-2)	Below 135 mΩ at 20°C
V (I14-2) - W (I14-3)	Below 135 mΩ at 20°C
W (I14-3) - U (I14-1)	Below 135 mΩ at 20°C

*: Apply the formula given below to correct the resistance.

$$R_{20} = R_t / \{1 + 0.00393 \times (T - 20)\}$$

R₂₀: Resistance converted to 20°C (mΩ)

R_t: Resistance between measured lines (mΩ)

T: Ambient air temperature during measurement (°C)

- (f) Calculate the difference between the maximum and minimum resistance between terminals U - V, V - W, and W - U.

Standard resistance:

Below 2 mΩ

- (g) Using a megohmmeter, measure the insulation resistance between the three-phase alternating current cable terminals of the hybrid vehicle motor and the body ground.

Standard resistance

Tester Connection	Specified Condition
U (I14-1) - Body ground	10 MΩ or higher
V (I14-2) - Body ground	10 MΩ or higher
W (I14-3) - Body ground	10 MΩ or higher

- (h) Reconnect the three-phase alternating current cable for the hybrid vehicle motor.

NG

REPLACE HYBRID VEHICLE MOTOR ASSEMBLY

OK

6

INSPECT HYBRID VEHICLE GENERATOR ASSEMBLY

CAUTION:

Wear insulated gloves before performing the following operation.

- (a) Check that the service plug grip and inverter cover have been removed.

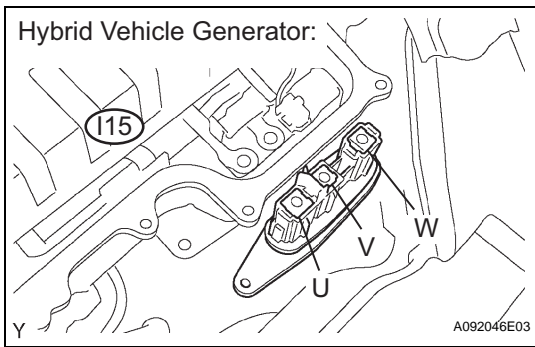

- (b) Disconnect the three-phase alternating current cable for the hybrid vehicle generator from the inverter.
- (c) Using a milliohm meter, measure the resistance between the three-phase alternating current cable terminals of the hybrid vehicle generator.

NOTICE:

If the generator temperature is too high, the resistance varies considerably, which hinders determining malfunction. Therefore, measure the resistance at a minimum 8 hours after the vehicle has been stopped.

Standard resistance

Tester Connection	Specified Condition*
U (I15-1) - V (I15-2)	Below 109 mΩ at 20°C
V (I15-2) - W (I15-3)	Below 109 mΩ at 20°C
W (I15-3) - U (I15-1)	Below 109 mΩ at 20°C

*: Apply the formula given below to correct the resistance.

$$R_{20} = R_t / \{1 + 0.00393 \times (T - 20)\}$$

R₂₀: Resistance converted to 20°C (mΩ)

R_t: Resistance between measured lines (mΩ)

T: Ambient air temperature during measurement (°C)

- (d) Calculate the difference between the maximum and minimum resistance between terminals U - V, V - W, and W - U.

Standard resistance:

Below 2 mΩ

- (e) Using a megohmmeter, measure the insulation resistance between the three-phase alternating current cable terminals of the hybrid vehicle generator and the body ground.

Standard resistance

Tester Connection	Specified Condition
U (I15-1) - Body ground	10 MΩ or higher
V (I15-2) - Body ground	10 MΩ or higher
W (I15-3) - Body ground	10 MΩ or higher

- (f) Reconnect the three-phase alternating current cable for the hybrid vehicle generator.

NG → **REPLACE HYBRID VEHICLE GENERATOR ASSEMBLY**

OK

7 PERFORM ACTIVE TEST BY INTELLIGENT TESTER (INVERTER STOP)

CAUTION:

Wear insulated gloves before performing the following operation.

- (a) Check that the service plug grip and inverter cover have been removed.
- (b) Connect the intelligent tester to the DLC3.

- (c) Turn the power switch ON (IG).
HINT:
DTCs for the interlock switch system are output when turning the power switch ON (IG) with both service plug grip and inverter cover removed.
- (d) Turn the intelligent tester ON.
- (e) Enter the following menus: DIAGNOSIS / OBD/MOBD / HV ECU / ACTIVE TEST.
- (f) Measure the voltage between the terminals of the inverter connector while effecting INVERTER STOP.
Standard voltage

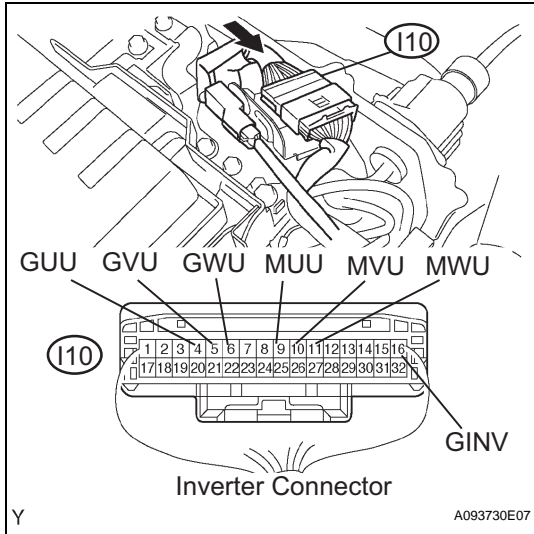

Tester Connection	Specified Condition
MUU (I10-9) - GINV (I10-16)	12 to 16 V
MVU (I10-10) - GINV (I10-16)	12 to 16 V
MWU (I10-11) - GINV (I10-16)	12 to 16 V
GUU (I10-4) - GINV (I10-16)	12 to 16 V
GVU (I10-5) - GINV (I10-16)	12 to 16 V
GWU (I10-6) - GINV (I10-16)	12 to 16 V

- (g) Turn the power switch OFF.

OK → **REPLACE INVERTER WITH CONVERTER ASSEMBLY**

NG

8 PERFORM ACTIVE TEST BY INTELLIGENT TESTER (INVERTER STOP)

HV

CAUTION:

Wear insulated gloves before performing the following operation.

- (a) Check that the service plug grip and inverter cover have been removed.
- (b) Disconnect the I10 inverter connector.
- (c) Connect the intelligent tester to the DLC3.
- (d) Turn the power switch ON (IG).
HINT:
DTCs for the interlock switch system are output when turning the power switch ON (IG) with both service plug grip and inverter cover removed.
- (e) Turn the intelligent tester ON.
- (f) Enter the following menus: DIAGNOSIS / OBD/MOBD / HV ECU / ACTIVE TEST.
- (g) Measure the voltage between the terminals of the inverter connector while effecting INVERTER STOP.
Standard voltage

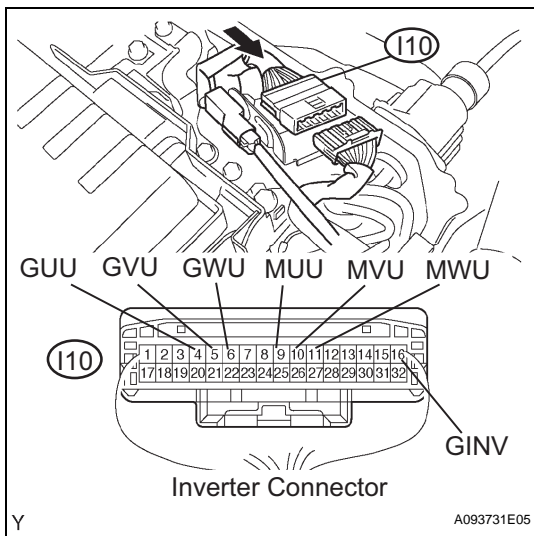

Tester Connection	Specified Condition
MUU (I10-9) - GINV (I10-16)	14 to 16 V
MVU (I10-10) - GINV (I10-16)	14 to 16 V
MWU (I10-11) - GINV (I10-16)	14 to 16 V
GUU (I10-4) - GINV (I10-16)	14 to 16 V
GVU (I10-5) - GINV (I10-16)	14 to 16 V

Tester Connection	Specified Condition
GWU (I10-6) - GINV (I10-16)	14 to 16 V

- (h) Turn the power switch OFF.
- (i) Reconnect the inverter connector.
- (j) Reinstall the inverter cover (see page [HV-538](#)).
- (k) Reinstall the service plug grip (see page [HB-154](#)).

NG**REPLACE INVERTER WITH CONVERTER ASSEMBLY****OK****REPLACE HYBRID VEHICLE CONTROL ECU**

DTC	P0A94-557	DC / DC Converter Performance
------------	------------------	--------------------------------------

DESCRIPTION

See the description of the booster converter (see page [HV-350](#)).

If the boost converter has a circuit malfunction, internal short, or overheats, the boost converter transmits that information to the FCV terminal of the HV control ECU via the boost converter fail signal line.

DTC No.	INF Code	DTC Detection Condition	Trouble Area
P0A94	557	Boost converter fail (FCV) signal detection (circuit malfunction)	<ul style="list-style-type: none"> Wire harness or connector Inverter with converter assembly

MONITOR DESCRIPTION

If the boost converter detects a circuit malfunction, it transmits a boost converter fail signal to the HV control ECU. Upon receiving this signal, the HV control ECU illuminates the MIL and sets a DTC.

MONITOR STRATEGY

Related DTCs	P0A94 (INF 557): FCV detection circuit malfunction
Required sensor / components	Boost converter
Frequency of operation	Continuous
Duration	TOYOTA's intellectual property
MIL operation	Immediately
Sequence of operation	None

TYPICAL ENABLING CONDITIONS

The monitor will run whenever the following DTCs are not present	TOYOTA's intellectual property
Other conditions belong to TOYOTA's intellectual property	-

TYPICAL MALFUNCTION THRESHOLDS

Boost converter	Circuit malfunction
-----------------	---------------------

COMPONENT OPERATING RANGE

Boost converter	DTC P0A94 (INF 557) is not detected
-----------------	-------------------------------------

WIRING DIAGRAM

Refer to DTC P0A78 (INF 282) (see page [HV-244](#)).

INSPECTION PROCEDURE

CAUTION:

- Before inspecting the high-voltage system, take safety precautions to prevent electrical shocks, such as wearing insulated gloves and removing the service plug grip. After removing the service plug grip, put it in your pocket to prevent other technicians from reconnecting it while you are servicing the high-voltage system.
- After disconnecting the service plug grip, wait for at least 5 minutes before touching any of the high-voltage connectors or terminals.

HINT:

At least 5 minutes are required to discharge the high-voltage condenser inside the inverter.

1 READ OUTPUT DTC (HV ECU)

- (a) Connect the intelligent tester to the DLC3.
- (b) Turn the power switch ON (IG).
- (c) Turn the intelligent tester ON.
- (d) Enter the following menus: DIAGNOSIS / OBD/MOBD / HV ECU / DTC INFO / CURRENT CODES.
- (e) Read DTCs.

Result:

DTC listed in the table below is output

DTC No.	INF Code	Detection Item	See Page
P0A94	551 or 552	DC / DC Converter Malfunction	HV-366

YES → **GO TO THE PAGE NUMBER SHOWN IN THE TABLE ABOVE**

NO

2 CHECK CONNECTION CONDITION OF INVERTER CONNECTOR (LOOSENESS AND POOR CONTACT)

CAUTION:

Wear insulated gloves before performing the following operation.

- (a) Turn the power switch OFF.
- (b) Remove the service plug grip (see page [HB-154](#)).

NOTICE:

Turning the power switch ON (READY) with the service plug grip removed could cause malfunction. Therefore, never turn the power switch ON (READY) in this state.

- (c) Remove the inverter cover (see page [HV-531](#)).
- (d) Check the connection condition of the I9 and I10 inverter connectors.

OK:

Connectors have been connected securely and there is no poor connection.

- (e) Reinstall the inverter cover (see page [HV-538](#)).
- (f) Reinstall the service plug grip (see page [HB-154](#)).

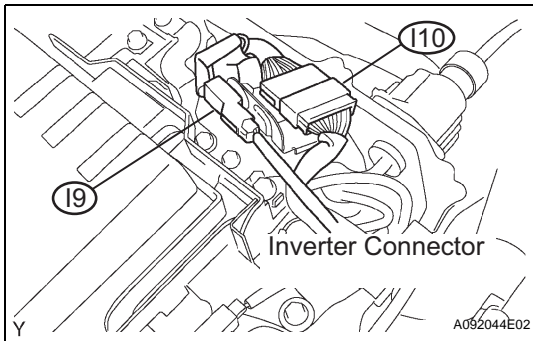

NG → **CONNECT SECURELY**

OK

3 READ OUTPUT DTC (HV ECU)

- (a) Connect the intelligent tester to the DLC3.
- (b) Turn the power switch ON (IG).

HINT:

DTCs for the interlock switch system are output when turning the power switch ON (IG) with both service plug grip and inverter cover removed.

- (c) Turn the intelligent tester ON.
- (d) Enter the following menus: DIAGNOSIS / OBD/MOBD / HV ECU / DTC INFO / CURRENT CODES.
- (e) Read DTCs.

Result:

DTCs P0A78 (INF 282, 286) and P0A7A (INF 324) (inverter circuit malfunction) are output

NO → **REPLACE INVERTER WITH CONVERTER ASSEMBLY**

YES

4 INSPECT INVERTER WITH CONVERTER ASSEMBLY (IGCT VOLTAGE)

CAUTION:

Wear insulated gloves before performing the following operation.

- (a) Turn the power switch OFF.
- (b) Remove the service plug grip (see page [HB-154](#)).

NOTICE:

Turning the power switch ON (READY) with the service plug grip removed could cause malfunction. Therefore, never turn the power switch ON (READY) in this state.

- (c) Remove the inverter cover (see page [HV-531](#)).
- (d) Turn the power switch ON (IG).

HINT:

DTCs for the interlock switch system are output when turning the power switch ON (IG) with both service plug grip and inverter cover removed.

- (e) Measure the voltage between the terminals of the inverter connector.

Standard voltage

Tester Connection	Specified Condition
IGCT (I9-1) - GND1 (I9-2)	8 V or more

- (f) Turn the power switch OFF.
- (g) Reinstall the inverter cover (see page [HV-538](#)).
- (h) Reinstall the service plug grip (see page [HB-154](#)).

NG → **REPAIR OR REPLACE HARNESS OR CONNECTOR**

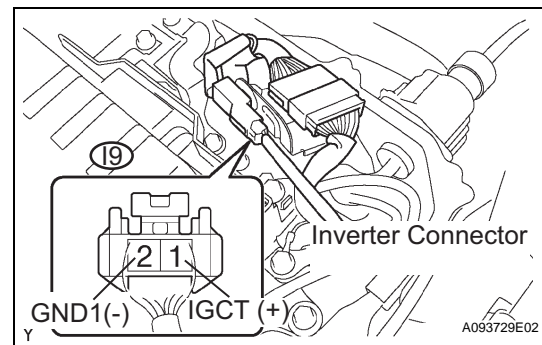

OK

REPLACE INVERTER WITH CONVERTER ASSEMBLY

HV

DTC	P0A94-558	DC / DC Converter Performance
DTC	P0A94-559	DC / DC Converter Performance
DTC	P0A94-560	DC / DC Converter Performance

DESCRIPTION

See the description of the boost converter (see page [HV-350](#)).

Upon receiving a boost converter gate shutdown signal from the HV control ECU, the boost converter forcefully stops the operation of the boost converter by turning OFF the power transistors that are actuating the boost converter.

The HV control ECU monitors the boost converter gate shutdown signal line and detects a malfunction.

DTC No.	INF Code	DTC Detection Condition	Trouble Area
P0A94	558	GND short in boost converter gate shutdown (CSDN) signal circuit	<ul style="list-style-type: none"> Wire harness or connector Inverter with converter assembly
P0A94	559	Open or +B short in boost converter gate shutdown (CSDN) signal circuit	<ul style="list-style-type: none"> Wire harness or connector Inverter with converter assembly
P0A94	560	Open in boost converter gate shutdown (CSDN) signal circuit	<ul style="list-style-type: none"> Wire harness or connector Inverter with converter assembly

MONITOR DESCRIPTION

The HV control ECU monitors the boost converter gate shutdown (CSDN) signal line. If the HV control ECU detects an open or short malfunction of the CSDN signal circuit, the HV control ECU illuminates the MIL and sets a DTC.

HV

MONITOR STRATEGY

Related DTCs	P0A94 (INF 558 / 559 / 560): Boost converter / Converter gate shutdown signal malfunction
Required sensor / components	Boost converter
Frequency of operation	Continuous
Duration	TOYOTA's intellectual property
MIL operation	1 driving cycle
Sequence of operation	None

TYPICAL ENABLING CONDITIONS

The monitor will run whenever the following DTCs are not present	TOYOTA's intellectual property
Other conditions belong to TOYOTA's intellectual property	-

TYPICAL MALFUNCTION THRESHOLDS

Boost converter gate shutdown signal circuit	Open or short
--	---------------

COMPONENT OPERATING RANGE

Boost converter

DTC P0A94 (INF 558 / 559 / 560) is not detected

WIRING DIAGRAM

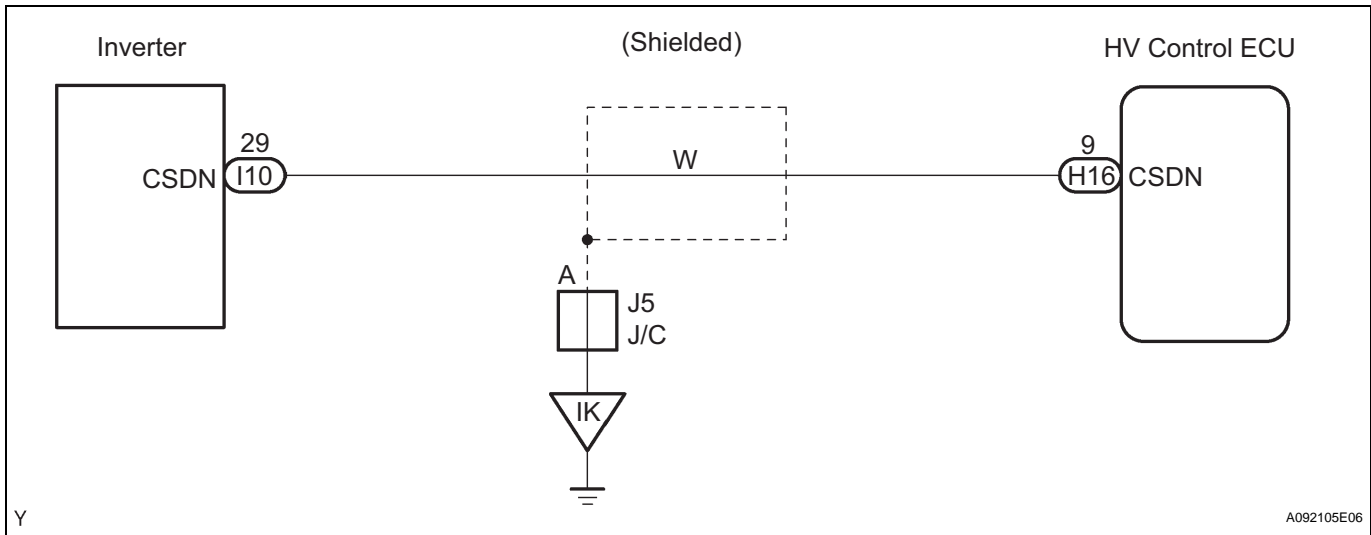

INSPECTION PROCEDURE

CAUTION:

- Before inspecting the high-voltage system, take safety precautions to prevent electrical shocks, such as wearing insulated gloves and removing the service plug grip. After removing the service plug grip, put it in your pocket to prevent other technicians from reconnecting it while you are servicing the high-voltage system.
- After disconnecting the service plug grip, wait for at least 5 minutes before touching any of the high-voltage connectors or terminals.

HV

HINT:

At least 5 minutes are required to discharge the high-voltage condenser inside the inverter.

1

CHECK HARNESS AND CONNECTOR (HYBRID VEHICLE CONTROL ECU - INVERTER)

CAUTION:

Wear insulated gloves before performing the following operation.

- Turn the power switch OFF.
- Remove the service plug grip (see page [HB-154](#)).

NOTICE:

Turning the power switch ON (READY) with the service plug grip removed could cause malfunction. Therefore, never turn the power switch ON (READY) in this state.

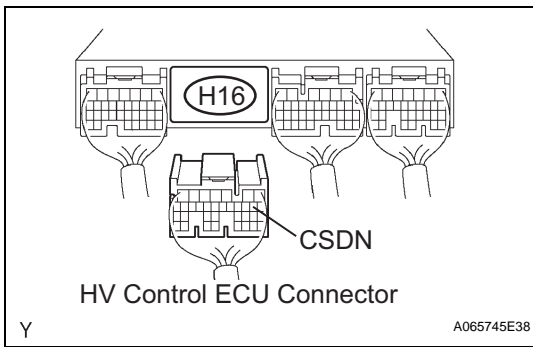

- (c) Disconnect the H16 HV control ECU connector.
- (d) Remove the inverter cover (see page HV-531).

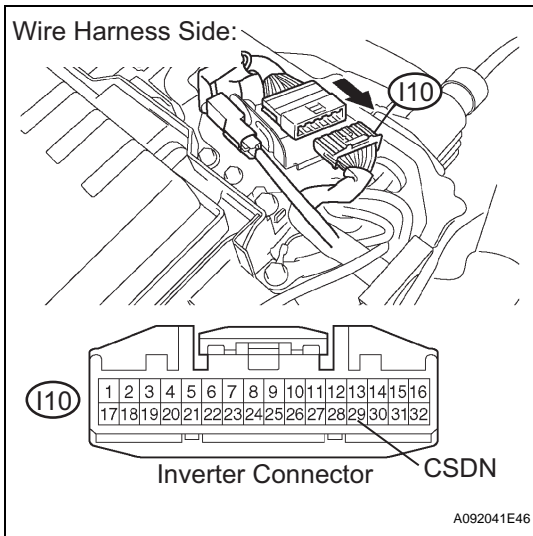

- (e) Disconnect the I10 inverter connector.
- (f) Turn the power switch ON (IG).
HINT:
DTCs for the interlock switch system are output when turning the power switch ON (IG) with both service plug grip and inverter cover removed.
- (g) Measure the voltage between the terminal of the HV control ECU connector and body ground.

Standard voltage

Tester Connection	Specified Condition
CSDN (H16-9) - Body ground	Below 1 V

- (h) Turn the power switch OFF.
- (i) Measure the resistance between the wire harness side connectors.

Standard resistance (Check for open)

Tester Connection	Specified Condition
CSDN (H16-9) - CSDN (I10-29)	Below 1 Ω

Standard resistance (Check for short)

Tester Connection	Specified Condition
CSDN (H16-9) or CSDN (I10-29) - Body ground	10 kΩ or higher

- (j) Reconnect the inverter connector.
- (k) Reconnect the HV control ECU connector.
- (l) Reinstall the inverter cover (see page HV-538).
- (m) Reinstall the service plug grip (see page HB-154).

NG → **REPAIR OR REPLACE HARNESS OR CONNECTOR**

OK

REPLACE INVERTER WITH CONVERTER ASSEMBLY

HV

DTC	P0A94-561	DC / DC Converter Performance
------------	------------------	--------------------------------------

DESCRIPTION

See the description of the boost converter (see page [HV-350](#)).

Upon receiving a boost converter gate shutdown signal from the HV control ECU, the boost converter forcefully stops the operation of the boost converter by turning OFF the power transistors that are actuating the boost converter.

The HV control ECU monitors the boost converter gate shutdown signal and detects a malfunction.

DTC No.	INF Code	DTC Detection Condition	Trouble Area
P0A94	561	Abnormal boost converter gate shutdown (CSDN) signal	<ul style="list-style-type: none"> • Wire harness or connector • HV control ECU

MONITOR DESCRIPTION

The HV control ECU monitors the boost converter gate shutdown (CSDN) signal. If the HV control ECU detects an abnormality in the CSDN signal, it illuminates the MIL and sets a DTC.

MONITOR STRATEGY

Related DTCs	P0A94 (INF 561): Boost converter / Converter shutdown signal line malfunction
Required sensor / components	Boost converter
Frequency of operation	Continuous
Duration	TOYOTA's intellectual property
MIL operation	Immediately
Sequence of operation	None

HV

TYPICAL ENABLING CONDITIONS

The monitor will run whenever the following DTCs are not present	TOYOTA's intellectual property
Other conditions belong to TOYOTA's intellectual property	-

TYPICAL MALFUNCTION THRESHOLDS

Actual status of shutdown command signal and its monitoring result	Inconsistent
--	--------------

COMPONENT OPERATING RANGE

Boost converter	DTC P0A94 (INF 561) is not detected
-----------------	-------------------------------------

WIRING DIAGRAM

Refer to DTC P0A94 (INF 558) (see page [HV-390](#)).

INSPECTION PROCEDURE

CAUTION:

- Before inspecting the high-voltage system, take safety precautions to prevent electrical shocks, such as wearing insulated gloves and removing the service plug grip. After removing the service plug grip, put it in your pocket to prevent other technicians from reconnecting it while you are servicing the high-voltage system.
- After disconnecting the service plug grip, wait for at least 5 minutes before touching any of the high-voltage connectors or terminals.

HINT:

At least 5 minutes are required to discharge the high-voltage condenser inside the inverter.

1 READ OUTPUT DTC (HV ECU)

- (a) Connect the intelligent tester to the DLC3.
- (b) Turn the power switch ON (IG).
- (c) Turn the intelligent tester ON.
- (d) Enter the following menus: DIAGNOSIS / OBD/MOBD / HV ECU / DTC INFO / CURRENT CODES.
- (e) Read DTCs.

Result:

DTC P0A94 (INF 561) and other DTCs are output

HINT:

If any other codes besides P0A94 (INF 561) are output, perform troubleshooting for those DTCs first.

YES

GO TO RELEVANT DTC CHART

NO

2 CHECK HARNESS AND CONNECTOR (HYBRID VEHICLE CONTROL ECU - INVERTER)

CAUTION:

Wear insulated gloves before performing the following operation.

- (a) Turn the power switch OFF.
- (b) Remove the service plug grip (see page [HB-154](#)).

NOTICE:

Turning the power switch ON (READY) with the service plug grip removed could cause malfunction. Therefore, never turn the power switch ON (READY) in this state.

- (c) Disconnect the H16 HV control ECU connector.
- (d) Remove the inverter cover (see page [HV-531](#)).

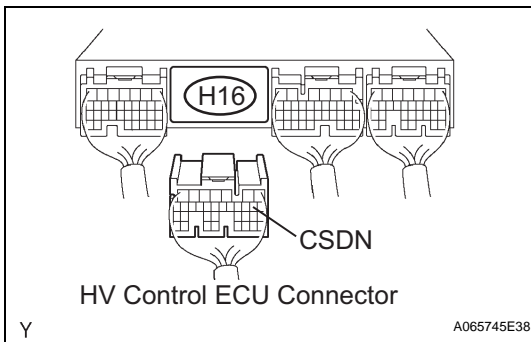

HV

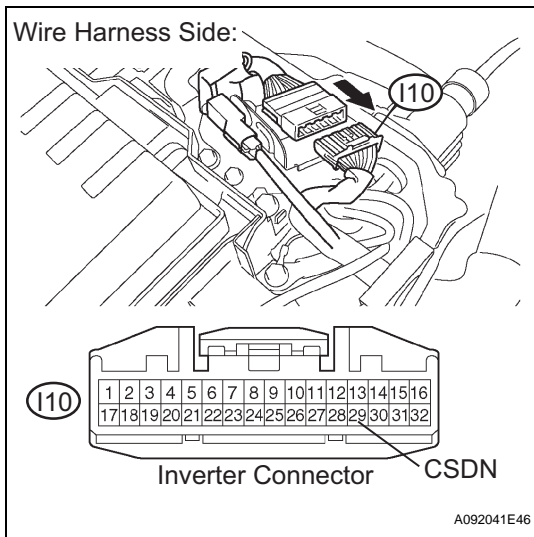

- (e) Disconnect the I10 inverter connector.
- (f) Turn the power switch ON (IG).
HINT:
DTCs for the interlock switch system are output when turning the power switch ON (IG) with both service plug grip and inverter cover removed.
- (g) Measure the voltage between the terminal of the HV control ECU connector and body ground.

Standard voltage

Tester Connection	Specified Condition
CSDN (H16-9) - Body ground	Below 1 V

- (h) Turn the power switch OFF.
- (i) Measure the resistance between the wire harness side connectors.

Standard resistance (Check for open)

Tester Connection	Specified Condition
CSDN (H16-9) - CSDN (I10-29)	Below 1 Ω

Standard resistance (Check for short)

Tester Connection	Specified Condition
CSDN (H16-9) or CSDN (I10-29) - Body ground	10 kΩ or higher

- (j) Reconnect the inverter connector.
- (k) Reconnect the HV control ECU connector.
- (l) Reinstall the inverter cover (see page [HV-538](#)).
- (m) Reinstall the service plug grip (see page [HB-154](#)).

NG	REPAIR OR REPLACE HARNESS OR CONNECTOR
-----------	---

HV

OK

REPLACE HYBRID VEHICLE CONTROL ECU

DTC	P0A94-583	DC / DC Converter Performance
DTC	P0A94-584	DC / DC Converter Performance

DESCRIPTION

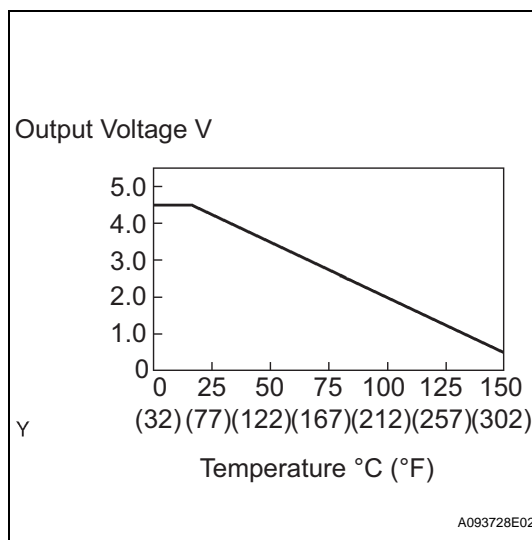

See the description of the boost converter (see page HV-350).

The HV control ECU uses a temperature sensor, which is built into the boost converter, to detect the temperature of the boost converter.

The boost converter temperature sensor outputs a voltage, which varies between 0 and 5 V in accordance with the changes in the temperature. The higher the boost converter temperature, the lower the output voltage. Conversely, the lower the temperature, the higher the output voltage.

The HV control ECU limits the load based on the signals transmitted by the boost converter temperature sensor, in order to prevent the boost converter from overheating. Furthermore, the HV control ECU detects a malfunction in the wiring of the boost converter temperature sensor, as well as in the sensor itself.

HV

DTC No.	INF Code	DTC Detection Condition	Trouble Area
P0A94	583	Open or GND short in boost converter temperature sensor circuit	<ul style="list-style-type: none"> Wire harness or connector Inverter with converter assembly HV control ECU
P0A94	584	+B short in boost converter temperature sensor circuit	<ul style="list-style-type: none"> Wire harness or connector Inverter with converter assembly HV control ECU

HINT:

After confirming DTC P0A94 (INF 583 or 584), confirm CONVERTER TEMP in DIAGNOSIS / OBD/MOBD / HV ECU / DATA LIST using the intelligent tester.

Temperature Displayed	Malfunction
-50°C (-58°F)	+B short circuit
205°C (401°F)	Open or GND short circuit

MONITOR DESCRIPTION

The HV control ECU monitors the boost converter temperature sensor circuit. If the HV control ECU detects an open or short malfunction of the sensor circuit, the HV control ECU illuminates the MIL and sets a DTC.

MONITOR STRATEGY

Related DTCs	P0A94 (INF 583 / 584): Boost converter / Converter temperature sensor malfunction
Required sensor / components	Boost converter
Frequency of operation	Continuous
Duration	TOYOTA's intellectual property
MIL operation	1 driving cycle
Sequence of operation	None

TYPICAL ENABLING CONDITIONS

The monitor will run whenever the following DTCs are not present	TOYOTA's intellectual property
Other conditions belong to TOYOTA's intellectual property	-

TYPICAL MALFUNCTION THRESHOLDS

Boost converter temperature sensor circuit	Open or short
--	---------------

COMPONENT OPERATING RANGE

Boost converter	DTC P0A94 (INF 583 / 584) is not detected
-----------------	---

WIRING DIAGRAM

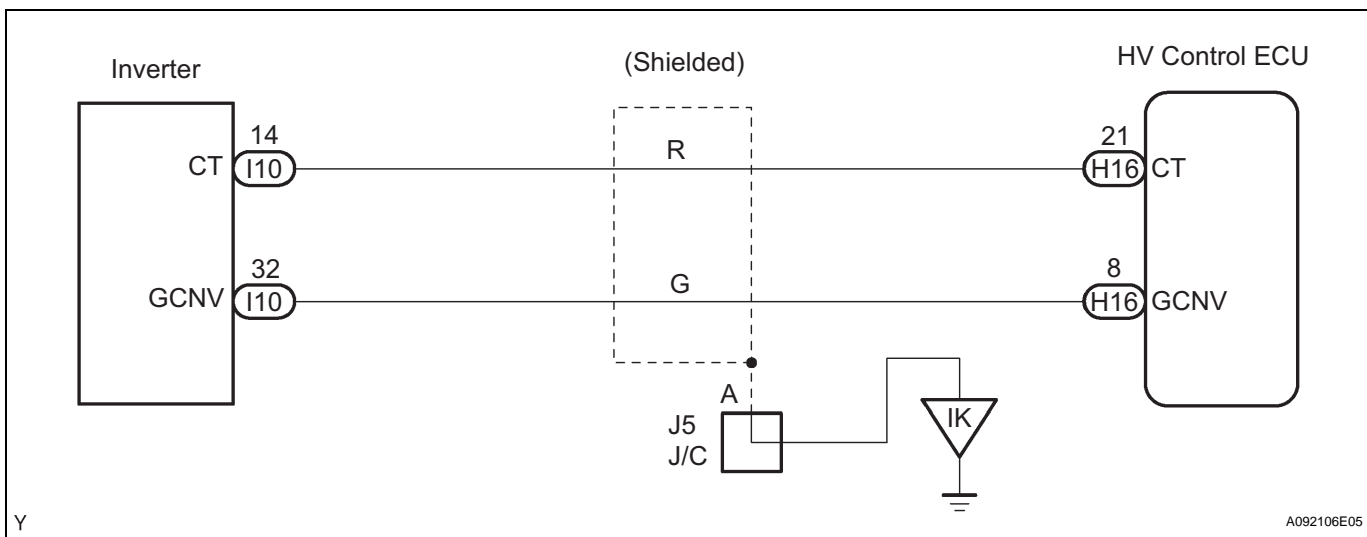

INSPECTION PROCEDURE

CAUTION:

- Before inspecting the high-voltage system, take safety precautions to prevent electrical shocks, such as wearing insulated gloves and removing the service plug grip. After removing the service plug grip, put it in your pocket to prevent other technicians from reconnecting it while you are servicing the high-voltage system.

- After disconnecting the service plug grip, wait for at least 5 minutes before touching any of the high-voltage connectors or terminals.

HINT:

At least 5 minutes are required to discharge the high-voltage condenser inside the inverter.

1 READ VALUE OF INTELLIGENT TESTER (CONVERTER TEMP)

- (a) Connect the intelligent tester to the DLC3.
- (b) Turn the power switch ON (IG).
- (c) Turn the intelligent tester ON.
- (d) Enter the following menus: DIAGNOSIS / OBD/MOBD / HV ECU / DATA LIST.
- (e) Read the CONVERTER TEMP value.

Result:

Temperature Displayed	Proceed to
-50°C (-58°F)	A
205°C (401°F)	B
-49°C to 204°C (-57°F to 400°F)	C

HINT:

- If there is a +B short circuit, the intelligent tester indicates -50°C (-58°F).
- If there is an open or GND short circuit, the intelligent tester indicates 205°C (401°F).

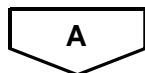
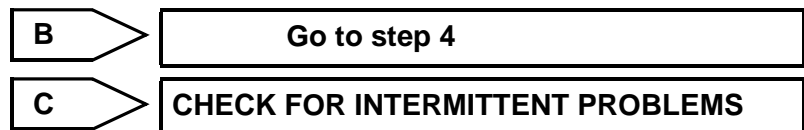

2 READ VALUE OF INTELLIGENT TESTER (CHECK FOR +B SHORT IN WIRE HARNESS)

CAUTION:

Wear insulated gloves before performing the following operation.

- (a) Turn the power switch OFF.
- (b) Remove the service plug grip (see page [HB-154](#)).

NOTICE:

Turning the power switch ON (READY) with the service plug grip removed could cause malfunction. Therefore, never turn the power switch ON (READY) in this state.

- (c) Remove the inverter cover (see page [HV-531](#)).

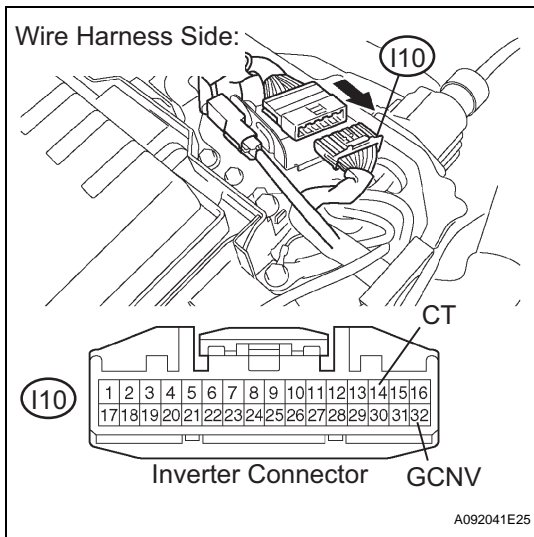

(d) Disconnect the I10 inverter connector.

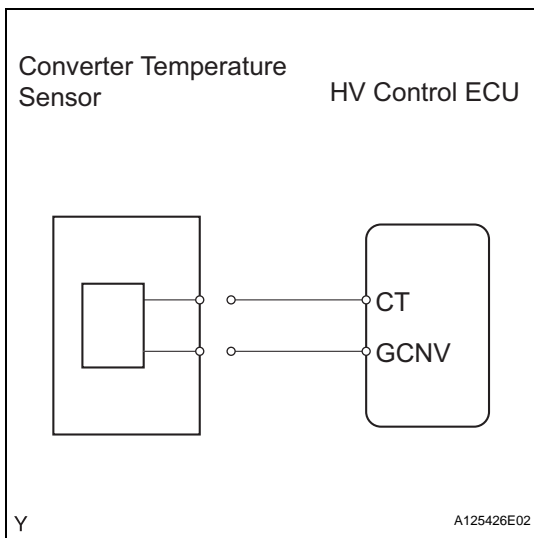

(e) Turn the power switch ON (IG).

HINT:

DTCs for the interlock switch system are output when turning the power switch ON (IG) with both service plug grip and inverter cover removed.

(f) Enter the following menus: DIAGNOSIS / OBD/MOBD / HV ECU / DATA LIST.

(g) Read the CONVERTER TEMP value.

OK:

205°C (401°F)

(h) Turn the power switch OFF.

(i) Reconnect the inverter connector.

(j) Reinstall the inverter cover (see page HV-538).

(k) Reinstall the service plug grip (see page HB-154).

OK

REPLACE INVERTER WITH CONVERTER ASSEMBLY

NG

3

READ VALUE OF INTELLIGENT TESTER (CHECK FOR +B SHORT IN HYBRID VEHICLE CONTROL ECU)

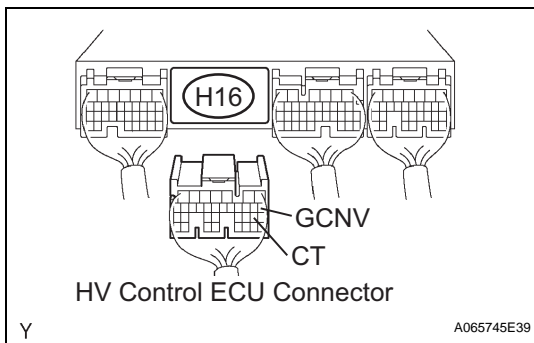

(a) Disconnect the H16 HV control ECU connector.

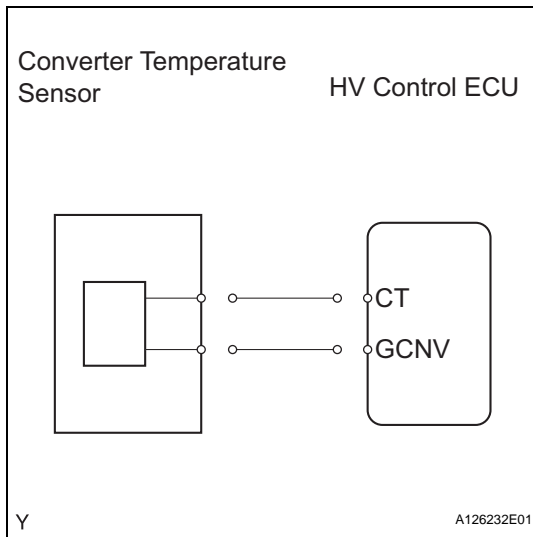

- (b) Turn the power switch ON (IG).
HINT:
DTCs for the interlock switch system are output when turning the power switch ON (IG) with both service plug grip and inverter cover removed.
- (c) Enter the following menus: DIAGNOSIS / OBD/MOBD / HV ECU / DATA LIST.
- (d) Read the CONVERTER TEMP value on the intelligent tester.
OK:
205°C (401°F)
- (e) Reconnect the HV control ECU connector.

NG → **REPLACE HYBRID VEHICLE CONTROL ECU**

OK

REPAIR OR REPLACE HARNESS OR CONNECTOR

4 CHECK HARNESS AND CONNECTOR (HYBRID VEHICLE CONTROL ECU - INVERTER)

CAUTION:
Wear insulated gloves before performing the following operation.

- (a) Turn the power switch OFF.
- (b) Remove the service plug grip (see page [HB-154](#)).

NOTICE:
Turning the power switch ON (READY) with the service plug grip removed could cause malfunction. Therefore, never turn the power switch ON (READY) in this state.

- (c) Remove the inverter cover (see page [HV-531](#)).
- (d) Disconnect the H16 HV control ECU connector.

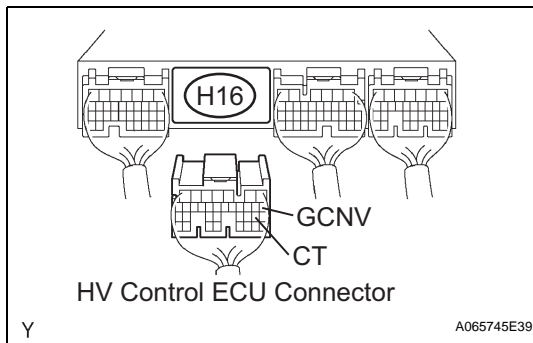

HV

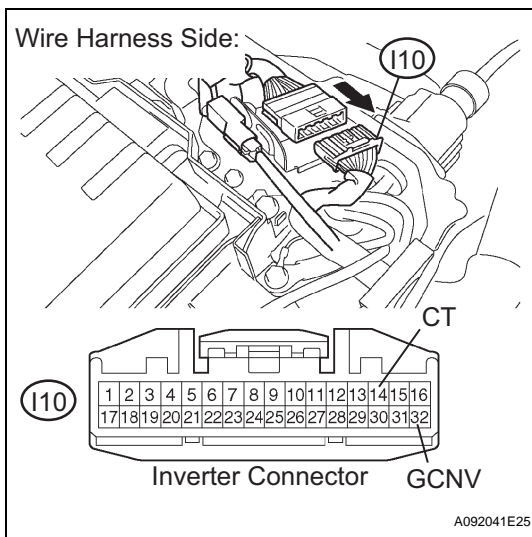

- (e) Disconnect the I10 inverter connector.
- (f) Measure the resistance between the wire harness side connectors.

Standard resistance (Check for open)

Tester Connection	Specified Condition
CT (H16-21) - CT (I10-14)	Below 1 Ω
GCNV (H16-8) - GCNV (I10-32)	Below 1 Ω

Standard resistance (Check for short)

Tester Connection	Specified Condition
CT (H16-21) or CT (I10-14) - Body ground	10 kΩ or higher
GCNV (H16-8) or GCNV (I10-32) - Body ground	10 kΩ or higher

- (g) Reconnect the inverter connector.
- (h) Reconnect the HV control ECU connector.
- (i) Reinstall the inverter cover (see page HV-538).
- (j) Reinstall the service plug grip (see page HB-154).

NG → **REPAIR OR REPLACE HARNESS OR CONNECTOR**

OK

5 INSPECT HYBRID VEHICLE CONTROL ECU (CT VOLTAGE)

HV

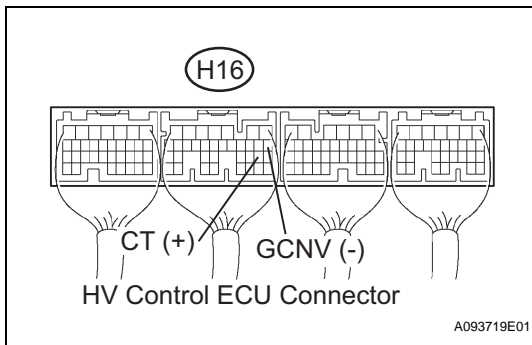

- (a) Turn the power switch ON (IG).
HINT:
DTCs for the interlock switch system are output when turning the power switch ON (IG) with both service plug grip and inverter cover removed.
- (b) Measure the voltage between the terminals of the H16 HV control ECU connector.

Standard voltage

Tester Connection	Specified Condition
CT (H16-21) - GCNV (H16-8)	2.0 to 4.5 V

NG → **REPLACE INVERTER WITH CONVERTER ASSEMBLY**

OK

REPLACE HYBRID VEHICLE CONTROL ECU

DTC	P0A94-585	DC / DC Converter Performance
------------	------------------	--------------------------------------

DESCRIPTION

Refer to DTC P0A94 (INF 589) (see page [HV-412](#)).

DTC No.	INF Code	DTC Detection Condition	Trouble Area
P0A94	585	Boost converter voltage (VL) sensor performance problem	<ul style="list-style-type: none"> Wire harness or connector Inverter with converter assembly

MONITOR DESCRIPTION

The HV control ECU monitors the boost converter voltage sensor signal. If the HV control ECU detects an abnormality in the sensor signal, it illuminates the MIL and sets a DTC.

MONITOR STRATEGY

Related DTCs	P0A94 (INF 585): Boost converter / Voltage (VL) sensor deviation
Required sensor / components	Boost converter, inverter, battery ECU
Frequency of operation	Continuous
Duration	TOYOTA's intellectual property
MIL operation	Immediately
Sequence of operation	None

TYPICAL ENABLING CONDITIONS

The monitor will run whenever the following DTCs are not present	TOYOTA's intellectual property
Other conditions belong to TOYOTA's intellectual property	-

TYPICAL MALFUNCTION THRESHOLDS

TOYOTA's intellectual property	-
--------------------------------	---

COMPONENT OPERATING RANGE

Boost converter	DTC P0A94 (INF 585) is not detected
-----------------	-------------------------------------

WIRING DIAGRAM

Refer to DTC P0A94 (INF 589) (see page [HV-413](#)).

INSPECTION PROCEDURE

CAUTION:

- Before inspecting the high-voltage system, take safety precautions to prevent electrical shocks, such as wearing insulated gloves and removing the service plug grip. After removing the service plug grip, put it in your pocket to prevent other technicians from reconnecting it while you are servicing the high-voltage system.
- After disconnecting the service plug grip, wait for at least 5 minutes before touching any of the high-voltage connectors or terminals.

HINT:

At least 5 minutes are required to discharge the high-voltage condenser inside the inverter.

1 READ OUTPUT DTC (HV ECU)

- (a) Connect the intelligent tester to the DLC3.
- (b) Turn the power switch ON (IG).
- (c) Turn the intelligent tester ON.
- (d) Enter the following menus: DIAGNOSIS / OBD/MOBD / HV ECU / DTC INFO / CURRENT CODES.
- (e) Read DTCs.

Result:

DTC P0A94 (INF 585) and other DTCs are output

HINT:

If any other codes besides P0A94 (INF 585) are output, perform troubleshooting for those DTCs first.

YES

GO TO RELEVANT DTC CHART

NO

2 CHECK HARNESS AND CONNECTOR (HYBRID VEHICLE CONTROL ECU - INVERTER)

CAUTION:

Wear insulated gloves before performing the following operation.

- (a) Turn the power switch OFF.
- (b) Remove the service plug grip (see page [HB-154](#)).

NOTICE:

Turning the power switch ON (READY) with the service plug grip removed could cause malfunction. Therefore, never turn the power switch ON (READY) in this state.

- (c) Disconnect the H16 HV control ECU connector.
- (d) Remove the inverter cover (see page [HV-531](#)).

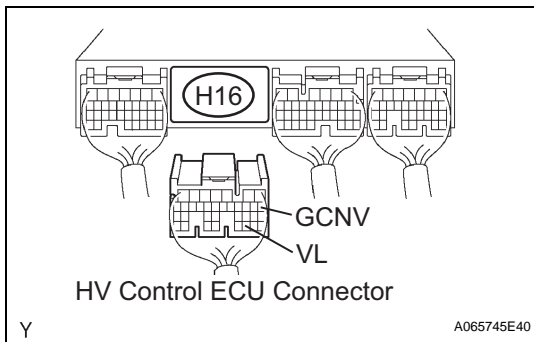

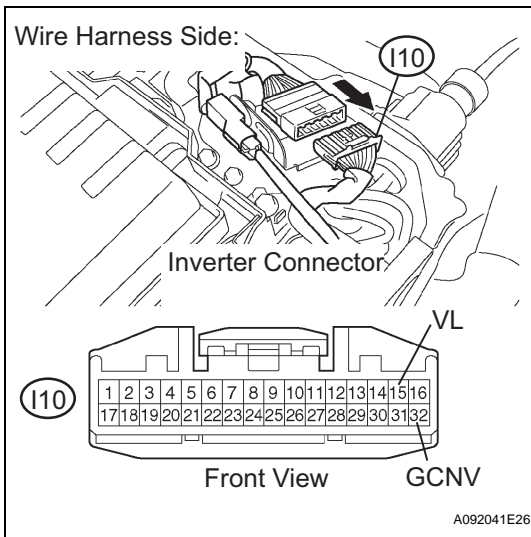

- (e) Disconnect the I10 inverter connector.
- (f) Turn the power switch ON (IG).
HINT:
DTCs for the interlock switch system are output when turning the power switch ON (IG) with both service plug grip and inverter cover removed.
- (g) Measure the voltage between the terminals of the HV control ECU connector and body ground.

Standard voltage

Tester Connection	Specified Condition
VL (H16-30) - Body ground	Below 1 V
GCNV (H16-8) - Body ground	Below 1 V

- (h) Turn the power switch OFF.
- (i) Measure the resistance between the wire harness side connectors.

Standard resistance (Check for open)

Tester Connection	Specified Condition
VL (H16-30) - VL (I10-15)	Below 1 Ω
GCNV (H16-8) - GCNV (I10-32)	Below 1 Ω

Standard resistance (Check for short)

Tester Connection	Specified Condition
VL (H16-30) or VL (I10-15) - Body ground	10 kΩ or higher
GCNV (H16-8) or GCNV (I10-32) - Body ground	10 kΩ or higher

- (j) Reconnect the inverter connector.
- (k) Reconnect the HV control ECU connector.
- (l) Reinstall the inverter cover (see page HV-538).
- (m) Reinstall the service plug grip (see page HB-154).

NG REPAIR OR REPLACE HARNESS OR CONNECTOR

OK

REPLACE INVERTER WITH CONVERTER ASSEMBLY

HV

DTC	P0A94- 587	DC / DC Converter Performance
------------	-----------------------	--------------------------------------

DESCRIPTION

See the description of the boost converter (see page [HV-350](#)).

The HV control ECU uses two voltage sensors, VL and VB, to detect voltage levels. The VL sensor that has been built into the boost converter is used to detect the high voltage before it is boosted. The VB sensor that has been built into the battery ECU is used to detect voltage of the HV battery.

DTC No.	INF Code	DTC Detection Condition	Trouble Area
P0A94	587	Difference between voltages from HV battery voltage (VB) sensor and boost converter voltage (VL) sensor is large	<ul style="list-style-type: none"> • Wire harness or connector • Inverter with converter assembly • Service plug grip • High voltage fuse • Battery ECU

MONITOR DESCRIPTION

The HV control ECU monitors signals of HV battery voltage (VB) and boost converter voltage (VL) sensors. When a large difference occurs between the voltages from the VB and VL sensors, the HV control ECU interprets this as a failure of either of the sensors. The HV control ECU then illuminates the MIL and sets a DTC.

MONITOR STRATEGY

Related DTCs	P0A94 (INF 587): Voltage (VB or VL) sensor deviation
Required sensor / components	Boost converter, battery ECU
Frequency of operation	Continuous
Duration	TOYOTA's intellectual property
MIL operation	Immediately
Sequence of operation	None

TYPICAL ENABLING CONDITIONS

The monitor will run whenever the following DTCs are not present	TOYOTA's intellectual property
Other conditions belong to TOYOTA's intellectual property	-

TYPICAL MALFUNCTION THRESHOLDS

Difference between the voltages of HV battery and boost converter voltage sensors	Exceeds the standard level
---	----------------------------

COMPONENT OPERATING RANGE

Boost converter Battery ECU	DTC P0A94 (INF 587) is not detected
--------------------------------	-------------------------------------

WIRING DIAGRAM

Refer to DTC P0A94 (INF 589) (see page [HV-413](#)).

INSPECTION PROCEDURE

CAUTION:

- Before inspecting the high-voltage system, take safety precautions to prevent electrical shocks, such as wearing insulated gloves and removing the service plug grip. After removing the service plug grip, put it in your pocket to prevent other technicians from reconnecting it while you are servicing the high-voltage system.
- After disconnecting the service plug grip, wait for at least 5 minutes before touching any of the high-voltage connectors or terminals.

HINT:

At least 5 minutes are required to discharge the high-voltage condenser inside the inverter.

1	READ OUTPUT DTC (HV ECU)
----------	---------------------------------

- (a) Connect the intelligent tester to the DLC3.
- (b) Turn the power switch ON (IG).
- (c) Turn the intelligent tester ON.
- (d) Enter the following menus: DIAGNOSIS / OBD/MOBD / HV ECU / DTC INFO / CURRENT CODES.
- (e) Read DTCs.

Result:

Display (DTC Output)	Proceed to
Only DTC P0A94 (INF 587)	A
DTCs P0A94 (INF 587), and P0A1F (INF 129) (HV battery voltage circuit malfunction)	B
DTCs P0A94 (INF 587), and P0A94 (INF 442) (Abnormal voltage execution value)	C
DTCs P0A94 (INF 587), and P0A94 (INF 585) (Boost converter voltage (VL) sensor performance problem)	D
DTCs other than above	E

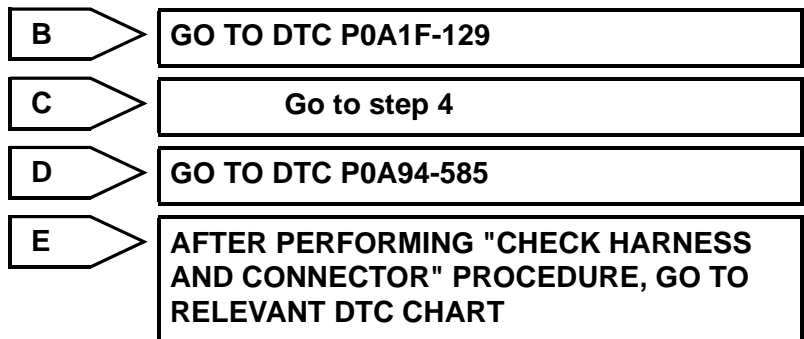

HV

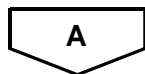

2	READ OUTPUT DTC (HV BATTERY)
----------	-------------------------------------

- (a) Connect the intelligent tester to the DLC3.
- (b) Turn the power switch ON (IG).
- (c) Turn the intelligent tester ON.
- (d) Enter the following menus: DIAGNOSIS / OBD/MOBD / HV BATTERY / DTC INFO / TROUBLE CODES.
- (e) Read DTCs.

Result:

DTCs are output

YES → **GO TO RELEVANT DTC CHART**

NO

3 INSPECT SERVICE PLUG GRIP

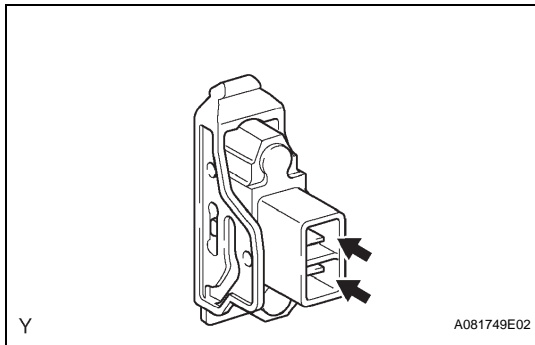

CAUTION:

Wear insulated gloves before performing the following operation.

- (a) Turn the power switch OFF.
- (b) Remove the service plug grip (see page [HB-154](#)).

NOTICE:

Turning the power switch ON (READY) with the service plug grip removed could cause malfunction. Therefore, never turn the power switch ON (READY) in this state.

- (c) Measure the resistance between the terminals of the service plug grip.

Standard resistance:

Below 1 Ω

- (d) Reinstall the service plug grip (see page [HB-154](#)).

NG → **Go to step 6**

OK

4 CHECK HARNESS AND CONNECTOR (HYBRID VEHICLE CONTROL ECU - INVERTER)

HV

CAUTION:

Wear insulated gloves before performing the following operation.

- (a) Turn the power switch OFF.
- (b) Remove the service plug grip (see page [HB-154](#)).

NOTICE:

Turning the power switch ON (READY) with the service plug grip removed could cause malfunction. Therefore, never turn the power switch ON (READY) in this state.

- (c) Disconnect the H16 HV control ECU connector.
- (d) Remove the inverter cover (see page [HV-531](#)).

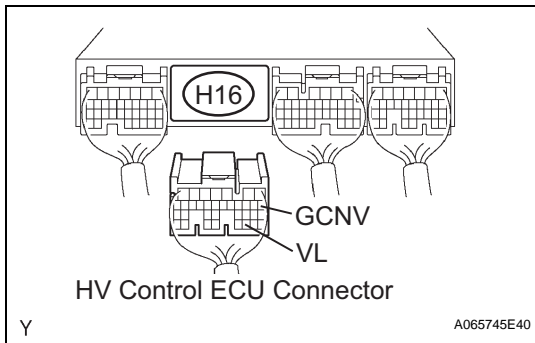

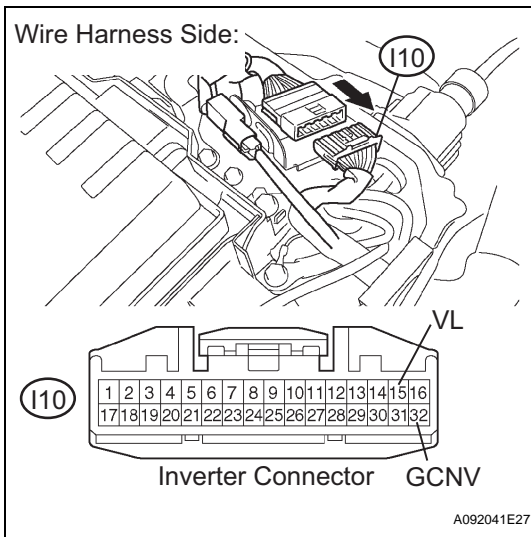

- (e) Disconnect the I10 inverter connector.
- (f) Turn the power switch ON (IG).
HINT:
DTCs for the interlock switch system are output when turning the power switch ON (IG) with both service plug grip and inverter cover removed.
- (g) Measure the voltage between the terminals of the HV control ECU connector and body ground.

Standard voltage

Tester Connection	Specified Condition
VL (H16-30) - Body ground	Below 1 V
GCNV (H16-8) - Body ground	Below 1 V

- (h) Turn the power switch OFF.
- (i) Measure the resistance between the wire harness side connectors.

Standard resistance (Check for open)

Tester Connection	Specified Condition
VL (H16-30) - VL (I10-15)	Below 1 Ω
GCNV (H16-8) - GCNV (I10-32)	Below 1 Ω

Standard resistance (Check for short)

Tester Connection	Specified Condition
VL (H16-30) or VL (I10-15) - Body ground	10 kΩ or higher
GCNV (H16-8) or GCNV (I10-32) - Body ground	10 kΩ or higher

- (j) Reconnect the inverter connector.
- (k) Reconnect the HV control ECU connector.
- (l) Reinstall the inverter cover (see page HV-538).
- (m) Reinstall the service plug grip (see page HB-154).

NG REPAIR OR REPLACE HARNESS OR CONNECTOR

OK

5 CHECK OUTPUT DTC

- (a) Proceed to A if only DTC P0A94 (INF 587) is output as a result of DTC reading in the "READ OUTPUT DTC" procedure.
- (b) Proceed to B if DTCs P0A94 (INF 587) and P0A94 (INF 442) are output as a result of DTC reading in the "READ OUTPUT DTC" procedure.

B REPLACE INVERTER WITH CONVERTER ASSEMBLY

A

REPLACE INVERTER WITH CONVERTER ASSEMBLY AND BATTERY ECU ASSEMBLY

HV

6 INSPECT HIGH VOLTAGE FUSE**CAUTION:**

Wear insulated gloves before performing the following operation.

- (a) Remove the high voltage fuse (see page [HB-154](#)).

HINT:

The high voltage fuse is enclosed in the service plug grip.

- (b) Measure the resistance between the terminals of the high voltage fuse.

Standard resistance:

Below 1 Ω

- (c) Reinstall the high voltage fuse (see page [HB-154](#)).

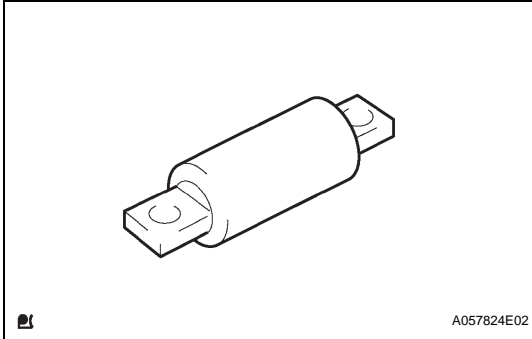
**NG****REPLACE HIGH VOLTAGE FUSE****OK****REPLACE SERVICE PLUG GRIP**

DTC	P0A94- 588	DC / DC Converter Performance
------------	-----------------------	--------------------------------------

DESCRIPTION

See the description of the boost converter (see page [HV-350](#)).

The boost converter switches the power transistors ON and OFF in accordance with the power transistor actuation signals received from the HV control ECU, in order to change the current that flows into the reactor.

Also, the boost converter regulates the duration of the switching time through PWM (Pulse Width Modulation) control, in order to control the boosting voltage.

The HV control ECU monitors the boost converter PWM circuit and detects a malfunction.

DTC No.	INF Code	DTC Detection Condition	Trouble Area
P0A94	588	Abnormality in boost converter PWM circuit	<ul style="list-style-type: none"> • Wire harness or connector • Inverter with converter assembly

MONITOR DESCRIPTION

The HV control ECU monitors the boost converter PWM circuit. If there is an error in the power transistor actuation signals which are transmitted to the boost converter, the HV control ECU interprets this as a malfunction of the boost converter PWM circuit.

The HV control ECU illuminates the MIL and sets a DTC.

MONITOR STRATEGY

Related DTCs	P0A94 (INF 588): Boost converter / Converter PWM malfunction
Required sensor / components	Boost converter
Frequency of operation	Continuous
Duration	TOYOTA's intellectual property
MIL operation	1 driving cycle
Sequence of operation	None

HV

TYPICAL ENABLING CONDITIONS

The monitor will run whenever the following DTCs are not present	TOYOTA's intellectual property
Other conditions belong to TOYOTA's intellectual property	-

TYPICAL MALFUNCTION THRESHOLDS

Power transistor actuation signal	Abnormal
-----------------------------------	----------

COMPONENT OPERATING RANGE

Boost converter	DTC P0A94 (INF 588) is not detected
-----------------	-------------------------------------

WIRING DIAGRAM

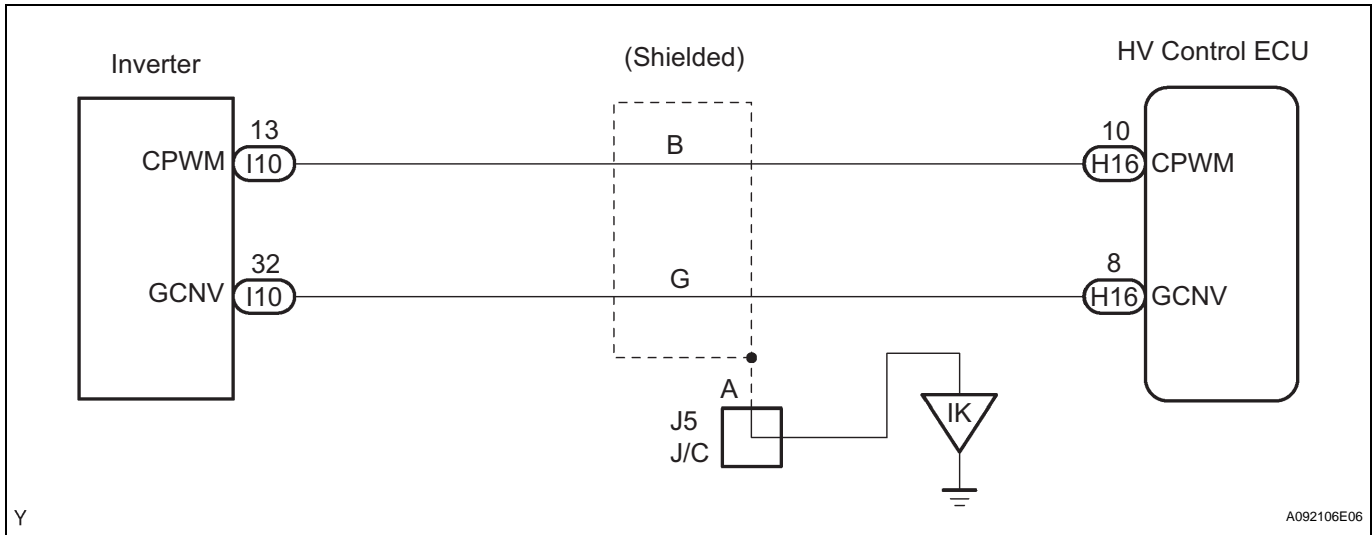

INSPECTION PROCEDURE

CAUTION:

- Before inspecting the high-voltage system, take safety precautions to prevent electrical shocks, such as wearing insulated gloves and removing the service plug grip. After removing the service plug grip, put it in your pocket to prevent other technicians from reconnecting it while you are servicing the high-voltage system.
- After disconnecting the service plug grip, wait for at least 5 minutes before touching any of the high-voltage connectors or terminals.

HINT:

At least 5 minutes are required to discharge the high-voltage condenser inside the inverter.

HV

1 CHECK HARNESS AND CONNECTOR (HYBRID VEHICLE CONTROL ECU - INVERTER)

CAUTION:

Wear insulated gloves before performing the following operation.

- Turn the power switch OFF.
- Remove the service plug grip (see page [HB-154](#)).

NOTICE:

Turning the power switch ON (READY) with the service plug grip removed could cause malfunction. Therefore, never turn the power switch ON (READY) in this state.

- Disconnect the H16 HV control ECU connector.
- Remove the inverter cover (see page [HV-531](#)).

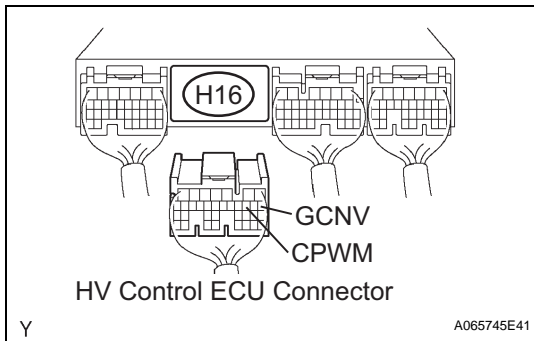

Y

A065745E41

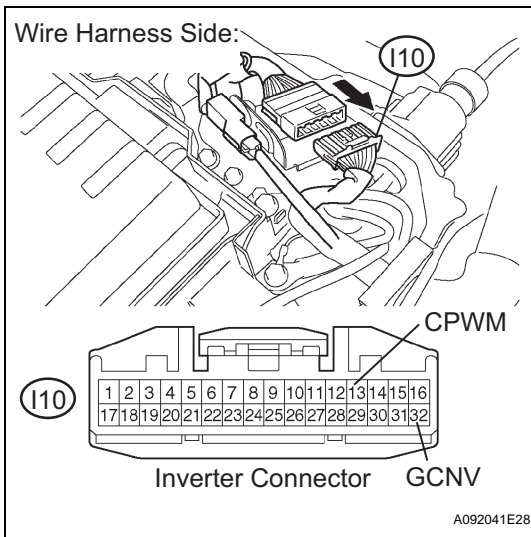

- (e) Disconnect the I10 inverter connector.
- (f) Turn the power switch ON (IG).
HINT:
DTCs for the interlock switch system are output when turning the power switch ON (IG) with both service plug grip and inverter cover removed.
- (g) Measure the voltage between the terminal of the HV control ECU connector and body ground.

Standard voltage

Tester Connection	Specified Condition
CPWM (H16-10) - Body ground	Below 1 V
GCNV (H16-8) - Body ground	Below 1 V

- (h) Turn the power switch OFF.
- (i) Measure the resistance between the wire harness side connectors.

Standard resistance (Check for open)

Tester Connection	Specified Condition
CPWM (H16-10) - CPWM (I10-13)	Below 1 Ω
GCNV (H16-8) - GCNV (I10-32)	Below 1 Ω

Standard resistance (Check for short)

Tester Connection	Specified Condition
CPWM (H16-10) or CPWM (I10-13) - Body ground	10 kΩ or higher
GCNV (H16-8) or GCNV (I10-32) - Body ground	10 kΩ or higher

- (j) Reconnect the inverter connector.
- (k) Reconnect the HV control ECU connector.
- (l) Reinstall the inverter cover (see page HV-538).
- (m) Reinstall the service plug grip (see page HB-154).

NG	REPAIR OR REPLACE HARNESS OR CONNECTOR
-----------	---

OK

REPLACE INVERTER WITH CONVERTER ASSEMBLY

HV

DTC	P0A94-589	DC / DC Converter Performance
------------	------------------	--------------------------------------

DTC	P0A94-590	DC / DC Converter Performance
------------	------------------	--------------------------------------

DESCRIPTION

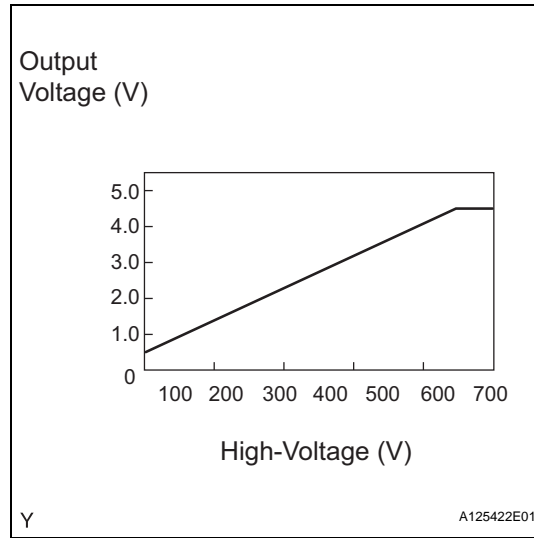

See the description of the boost converter (see page HV-350).

The HV control ECU uses a voltage sensor, which has been built into the boost converter, to detect the high voltage before it is boosted and for boost control.

The boost converter voltage sensor outputs a voltage that varies between 0 and 5 V in accordance with the changes in the high voltage. The higher the high voltage, the higher the output voltage, and the lower the high voltage, the lower the output voltage.

The HV control ECU monitors a signal line of the boost converter voltage sensor and detects a malfunction.

DTC No.	INF Code	DTC Detection Condition	Trouble Area
P0A94	589	Open or GND short in boost converter voltage (VL) sensor circuit	<ul style="list-style-type: none"> • Wire harness or connector • Inverter with converter assembly • HV control ECU
P0A94	590	+B short in boost converter voltage (VL) sensor circuit	<ul style="list-style-type: none"> • Wire harness or connector • Inverter with converter assembly • HV control ECU

HINT:

After confirming DTC P0A94 (INF 589 or 590), confirm VL in DIAGNOSIS / OBD/MOBD / HV ECU / DATA LIST using the intelligent tester.

Voltage Displayed	Malfunction
510 V	+B short circuit
0 V	Open or GND short circuit

MONITOR DESCRIPTION

The HV control ECU monitors the boost converter voltage (VL) sensor circuit. If the HV control ECU detects an open or short malfunction of the VL sensor circuit, the HV control ECU illuminates the MIL and sets a DTC.

HV

MONITOR STRATEGY

Related DTCs	P0A94 (INF 589 / 590): Boost converter / VL malfunction
Required sensor / components	Boost converter
Frequency of operation	Continuous
Duration	TOYOTA's intellectual property
MIL operation	1 driving cycle
Sequence of operation	None

TYPICAL ENABLING CONDITIONS

The monitor will run whenever the following DTCs are not present	TOYOTA's intellectual property
Other conditions belong to TOYOTA's intellectual property	-

TYPICAL MALFUNCTION THRESHOLDS

Boost converter voltage sensor circuit	Short
--	-------

COMPONENT OPERATING RANGE

Boost converter	DTC P0A94 (INF 589 / 590) is not detected
-----------------	---

WIRING DIAGRAM

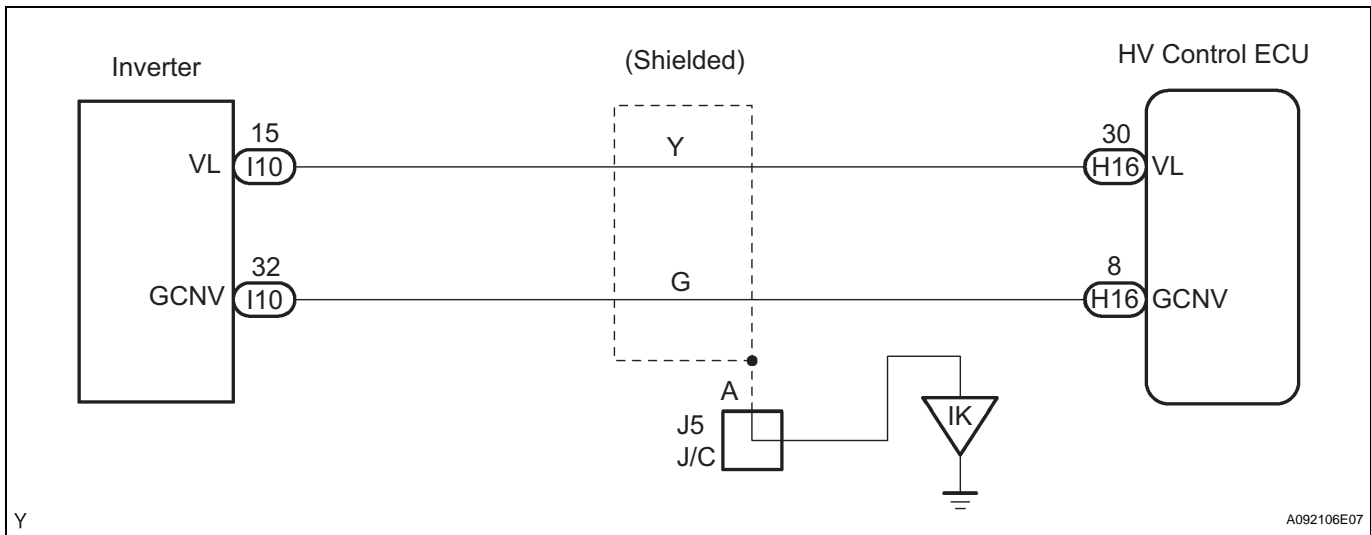

HV

INSPECTION PROCEDURE

CAUTION:

- Before inspecting the high-voltage system, take safety precautions to prevent electrical shocks, such as wearing insulated gloves and removing the service plug grip. After removing the service plug grip, put it in your pocket to prevent other technicians from reconnecting it while you are servicing the high-voltage system.
- After disconnecting the service plug grip, wait for at least 5 minutes before touching any of the high-voltage connectors or terminals.

HINT:

At least 5 minutes are required to discharge the high-voltage condenser inside the inverter.

1 READ VALUE OF INTELLIGENT TESTER (VL)

- (a) Connect the intelligent tester to the DLC3.
- (b) Turn the power switch ON (IG).
- (c) Turn the intelligent tester ON.
- (d) Enter the following menus: DIAGNOSIS / OBD/MOBD / HV ECU / DATA LIST.
- (e) Read the VL value.

Result:

Voltage Displayed	Proceed to
510 V	A
0 V	B
1 to 509 V	C

HINT:

- If there is a +B short circuit, the intelligent tester indicates 510 V.
- If there is an open or GND short circuit, the intelligent tester indicates 0 V.

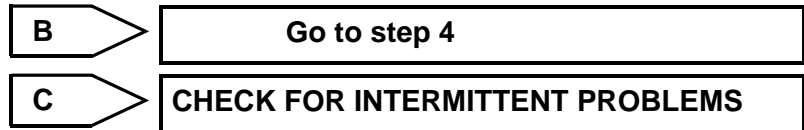

2 READ VALUE OF INTELLIGENT TESTER (CHECK FOR +B SHORT IN WIRE HARNESS)

HV

CAUTION:

Wear insulated gloves before performing the following operation.

- (a) Turn the power switch OFF.
- (b) Remove the service plug grip (see page [HB-154](#)).

NOTICE:

Turning the power switch ON (READY) with the service plug grip removed could cause malfunction. Therefore, never turn the power switch ON (READY) in this state.

- (c) Remove the inverter cover (see page [HV-531](#)).

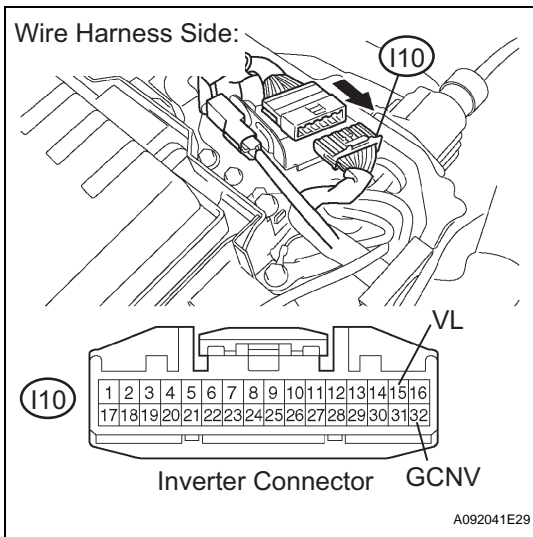

(d) Disconnect the I10 inverter connector.

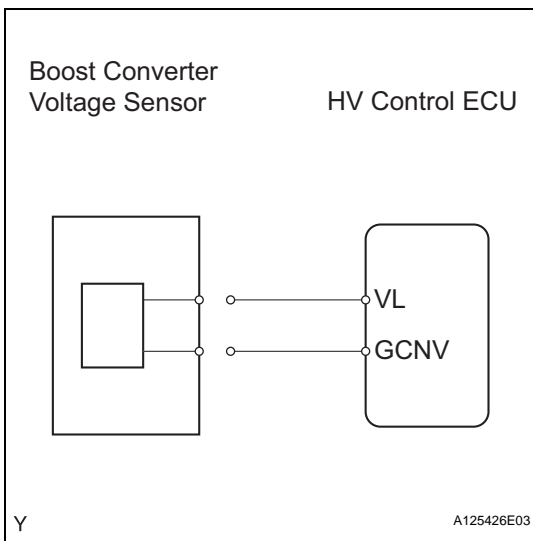

(e) Turn the power switch ON (IG).

HINT:

DTCs for the interlock switch system are output when turning the power switch ON (IG) with both service plug grip and inverter cover removed.

(f) Enter the following menus: DIAGNOSIS / OBD/MOBD / HV ECU / DATA LIST.

(g) Read the VL value.

Standard voltage:

0 V

(h) Turn the power switch OFF.

(i) Reconnect the inverter connector.

(j) Reinstall the inverter cover (see page HV-538).

(k) Reinstall the service plug grip (see page HB-154).

OK

REPLACE INVERTER WITH CONVERTER ASSEMBLY

NG

3 READ VALUE OF INTELLIGENT TESTER (CHECK FOR +B SHORT IN HYBRID VEHICLE CONTROL ECU)

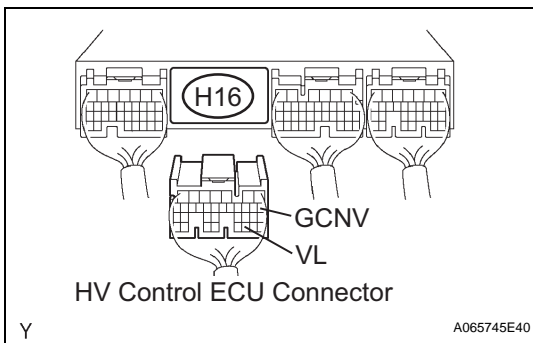

(a) Disconnect the H16 HV control ECU connector.

HV

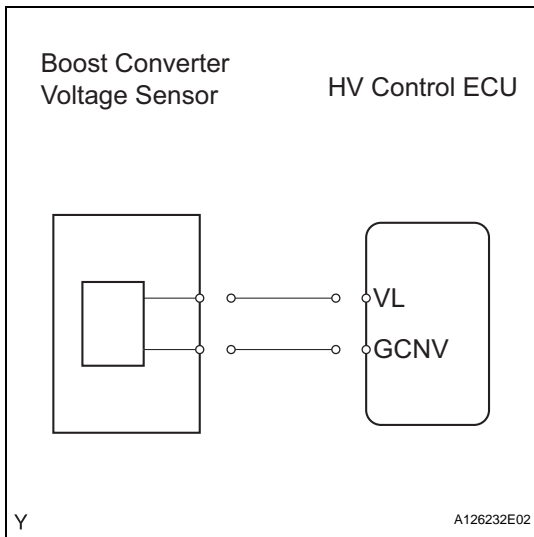

(b) Turn the power switch ON (IG).

HINT:

DTCs for the interlock switch system are output when turning the power switch ON (IG) with both service plug grip and inverter cover removed.

(c) Enter the following menus: DIAGNOSIS / OBD/MOBD / HV ECU / DATA LIST.

(d) Read the VL value.

Standard voltage:

0 V

(e) Reconnect the HV control ECU connector.

NG

REPLACE HYBRID VEHICLE CONTROL ECU

OK

REPAIR OR REPLACE HARNESS OR CONNECTOR

4

CHECK HARNESS AND CONNECTOR (HYBRID VEHICLE CONTROL ECU - INVERTER)

CAUTION:

Wear insulated gloves before performing the following operation.

(a) Turn the power switch OFF.

(b) Remove the service plug grip (see page [HB-154](#)).

NOTICE:

Turning the power switch ON (READY) with the service plug grip removed could cause malfunction. Therefore, never turn the power switch ON (READY) in this state.

(c) Remove the inverter cover (see page [HV-531](#)).

(d) Disconnect the H16 HV control ECU connector.

HV

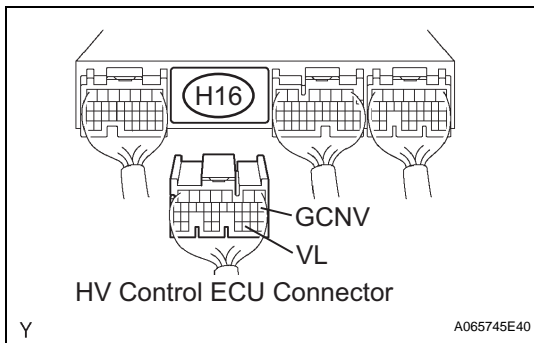

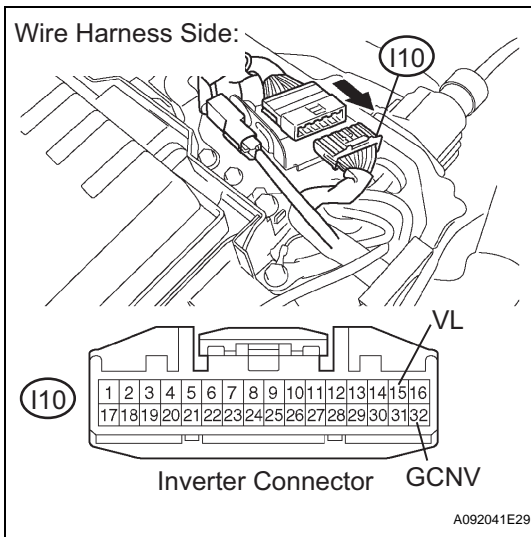

- (e) Disconnect the I10 inverter connector.
- (f) Measure the resistance between the wire harness side connectors.

Standard resistance (Check for open)

Tester Connection	Specified Condition
VL (H16-30) - VL (I10-15)	Below 1 Ω
GCNV (H16-8) - GCNV (I10-32)	Below 1 Ω

Standard resistance (Check for short)

Tester Connection	Specified Condition
VL (H16-30) or VL (I10-15) - Body ground	10 kΩ or higher
GCNV (H16-8) or GCNV (I10-32) - Body ground	10 kΩ or higher

- (g) Reconnect the inverter connector.
- (h) Reconnect the HV control ECU connector.
- (i) Reinstall the inverter cover (see page HV-538).
- (j) Reinstall the service plug grip (see page HB-154).

NG → **REPAIR OR REPLACE HARNESS OR CONNECTOR**

OK

5 CHECK HYBRID VEHICLE CONTROL ECU (VL VOLTAGE)

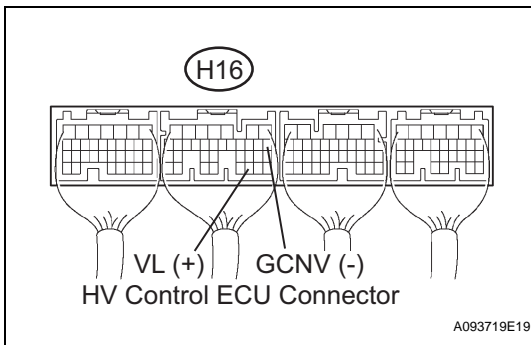

- (a) Turn the power switch ON (READY).
HINT:
DTCs for the interlock switch system are output when turning the power switch ON (IG) with both service plug grip and inverter cover removed.
- (b) Measure the voltage between the terminals of the H16 HV control ECU connector.

Standard voltage

Tester Connection	Specified Condition
VL (H16-30) - GCNV (H16-8)	1.9 to 3.4 V

NG → **REPLACE INVERTER WITH CONVERTER ASSEMBLY**

OK

REPLACE HYBRID VEHICLE CONTROL ECU

HV

DTC	P0AA1-231	Hybrid Battery Positive Contactor Circuit Stuck Closed
------------	------------------	---

DESCRIPTION

Refer to DTC P0AE7 (INF 224) (see page [HV-444](#)).

Because it might be impossible to shut off the high-voltage system if either of the No. 1 and No. 2 system main relays becomes stuck, the HV control ECU monitors the two relays and stops the system if malfunction is found in either relay.

DTC No.	INF Code	DTC Detection Condition	Trouble Area
P0AA1	231	System main relay terminal of HV battery positive side stuck closed	<ul style="list-style-type: none"> • No. 1 system main relay • No. 2 system main relay

INSPECTION PROCEDURE**CAUTION:**

- Before inspecting the high-voltage system, take safety precautions to prevent electrical shocks, such as wearing insulated gloves and removing the service plug grip. After removing the service plug grip, put it in your pocket to prevent other technicians from reconnecting it while you are servicing the high-voltage system.
- After disconnecting the service plug grip, wait for at least 5 minutes before touching any of the high-voltage connectors or terminals.

HINT:

At least 5 minutes are required to discharge the high-voltage condenser inside the inverter.

1	INSPECT NO. 1 SYSTEM MAIN RELAY
----------	--

(a) Inspect the No. 1 system main relay (see page [HB-124](#)).

NG

REPLACE NO. 1 SYSTEM MAIN RELAY

OK

REPLACE NO. 2 SYSTEM MAIN RELAY

HV

DTC	P0AA1-233	Hybrid Battery Positive Contactor Circuit Stuck Closed
------------	------------------	---

DESCRIPTION

Refer to DTC P0AE7 (INF 224) (see page [HV-444](#)).

Because it might be impossible to shut off the high-voltage system if any one of the No. 1 to No. 3 system main relays becomes stuck, the HV control ECU monitors the 3 relays and stops the system if malfunction is found in either relay.

DTC No.	INF Code	DTC Detection Condition	Trouble Area
P0AA1	233	System main relay terminals of HV battery positive and negative sides stuck closed	<ul style="list-style-type: none"> • No. 1 system main relay • No. 2 system main relay • No. 3 system main relay

INSPECTION PROCEDURE

CAUTION:

- Before inspecting the high-voltage system, take safety precautions to prevent electrical shocks, such as wearing insulated gloves and removing the service plug grip. After removing the service plug grip, put it in your pocket to prevent other technicians from reconnecting it while you are servicing the high-voltage system.
- After disconnecting the service plug grip, wait for at least 5 minutes before touching any of the high-voltage connectors or terminals.

HINT:

At least 5 minutes are required to discharge the high-voltage condenser inside the inverter.

1 INSPECT NO. 1 SYSTEM MAIN RELAY

(a) Inspect the No. 1 system main relay (see page [HB-124](#)).

NG → **REPLACE NO. 1 SYSTEM MAIN RELAY**

HV

OK

2 INSPECT NO. 2 SYSTEM MAIN RELAY

(a) Inspect the No. 2 system main relay (see page [HB-126](#)).

NG → **REPLACE NO. 2 SYSTEM MAIN RELAY**

OK

REPLACE NO. 3 SYSTEM MAIN RELAY

DTC	P0AA4-232	Hybrid Battery Negative Contactor Circuit Stuck Closed
------------	------------------	---

DESCRIPTION

Refer to DTC P0AE7 (INF 224) (see page [HV-444](#)).

DTC No.	INF Code	DTC Detection Condition	Trouble Area
P0AA4	232	System main relay terminal of HV battery negative side stuck closed	<ul style="list-style-type: none"> No. 3 system main relay

MONITOR DESCRIPTION

The HV control ECU monitors the No. 3 system main relay, because shutting off the high-voltage system might be impossible if the relay terminal becomes stuck. If the HV control ECU detects that the relay terminal has stuck closed, it illuminates the MIL and sets a DTC.

MONITOR STRATEGY

Related DTCs	P0AA4 (INF 232): SMR circuit / "-" side stuck
Required sensor / components	No. 3 system main relay
Frequency of operation	Continuous
Duration	TOYOTA's intellectual property
MIL operation	Immediately
Sequence of operation	None

TYPICAL ENABLING CONDITIONS

The monitor will run whenever the following DTCs are not present	TOYOTA's intellectual property
Other conditions belong to TOYOTA's intellectual property	-

HV**TYPICAL MALFUNCTION THRESHOLDS**

TOYOTA's intellectual property	-
--------------------------------	---

COMPONENT OPERATING RANGE

No. 3 system main relay	DTC P0AA4 (INF 232) is not detected
-------------------------	-------------------------------------

INSPECTION PROCEDURE

If the information (INF) code is present, replace the No. 3 system main relay.

1	REPLACE NO. 3 SYSTEM MAIN RELAY
----------	--

- (a) Replace the No. 3 system main relay (see page [HB-124](#)).

NEXT

COMPLETED

DTC	P0AA6-526	Hybrid Battery Voltage System Isolation Fault
DTC	P0AA6-611	Hybrid Battery Voltage System Isolation Fault
DTC	P0AA6-612	Hybrid Battery Voltage System Isolation Fault
DTC	P0AA6-613	Hybrid Battery Voltage System Isolation Fault
DTC	P0AA6-614	Hybrid Battery Voltage System Isolation Fault

DESCRIPTION

DTC No.	INF Code	DTC Detection Condition	Trouble Area
P0AA6	526*1	Insulation resistance of high voltage circuit and body is low	<ul style="list-style-type: none"> • Frame wire • System main relay • System main resistor • HV battery assembly • Electric inverter compressor • Battery ECU • HV transaxle assembly • Inverter with converter assembly • Main battery cable • No. 2 main battery cable • Battery plug • No. 2 frame wire • Junction block
P0AA6	611*2	Insulation resistance of A/C compressor motor or A/C inverter is low	<ul style="list-style-type: none"> • Electric inverter compressor • Inverter with converter assembly
P0AA6	612*2	Insulation resistance of HV battery, battery ECU, system main relay, or system main resistor is low	<ul style="list-style-type: none"> • HV battery assembly • Battery ECU • System main relay • System main resistor • Main battery cable • No. 2 main battery cable • Battery plug • No. 2 frame wire • Junction block
P0AA6	613*2	Insulation resistance of HV transaxle or motor and generator inverters is low	<ul style="list-style-type: none"> • HV transaxle assembly • Inverter with converter assembly
P0AA6	614*2	Insulation resistance of motor and generator inverters, A/C inverter, system main relay, system main resistor, or frame wire is low	<ul style="list-style-type: none"> • Frame wire • System main relay • System main resistor • HV battery assembly • Inverter with converter assembly • Main battery cable • No. 2 main battery cable • Battery plug • No. 2 frame wire • Junction block

HINT:

*1: Stored simultaneously when DTC P0AA6 is set.

*2: Stored when a malfunction has been isolated after INF code 526 was set. INF code 611 to 614 are set next trip.

WIRING DIAGRAM

Outline of High-Voltage Circuit and Areas:

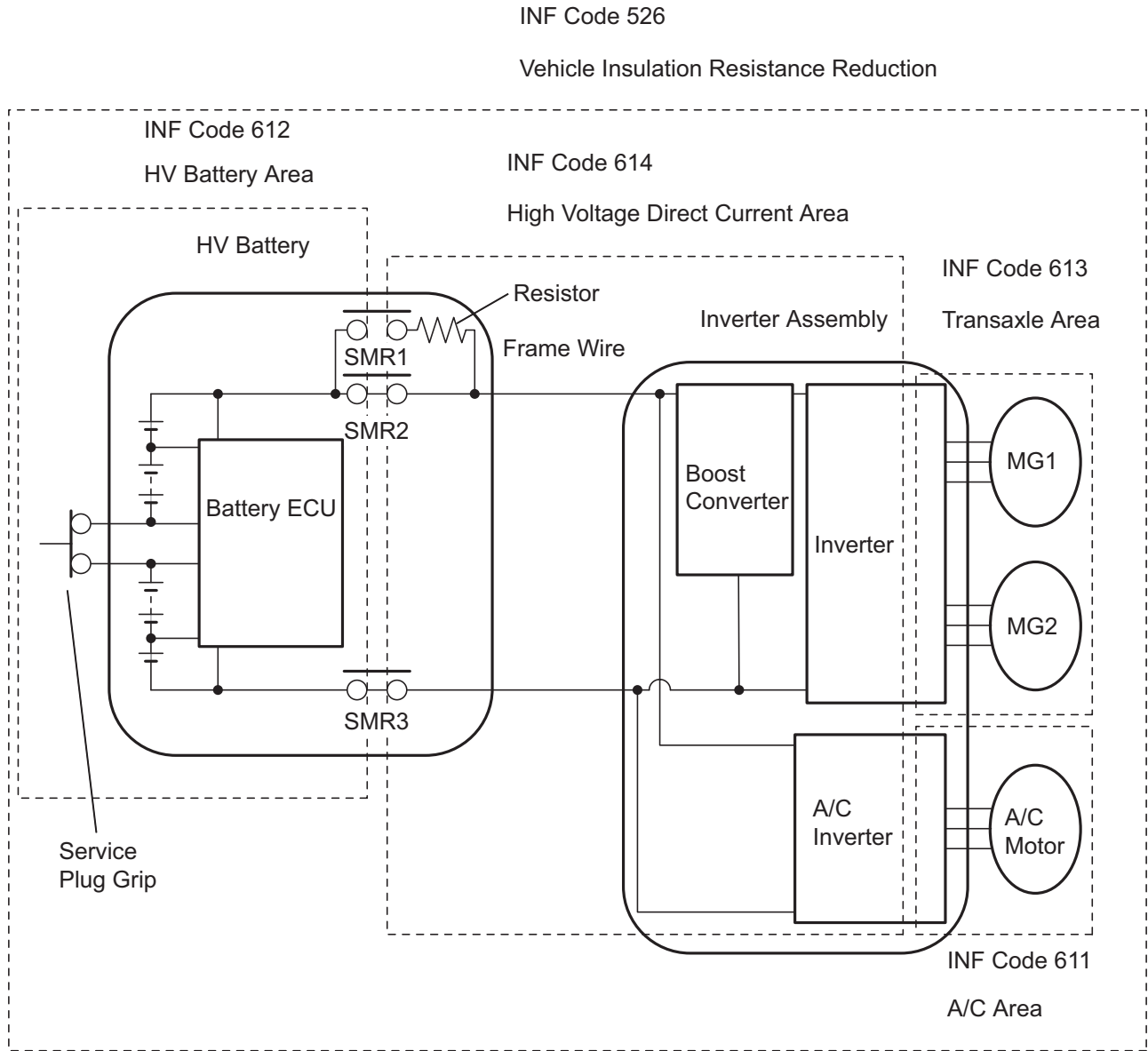

HV

INSPECTION PROCEDURE

CAUTION:

- Before inspecting the high-voltage system, take safety precautions to prevent electrical shocks, such as wearing insulated gloves and removing the service plug grip. After removing the service plug grip, put it in your pocket to prevent other technicians from reconnecting it while you are servicing the high-voltage system.
- After disconnecting the service plug grip, wait for at least 5 minutes before touching any of the high-voltage connectors or terminals.

HINT:

At least 5 minutes are required to discharge the high-voltage condenser inside the inverter.

1	READ OUTPUT DTC (HV ECU)
----------	---------------------------------

- (a) Connect the intelligent tester to the DLC3.
- (b) Turn the power switch ON (IG).
- (c) Turn the intelligent tester ON.
- (d) Enter the following menus: DIAGNOSIS / OBD/MOBD / HV ECU / DTC INFO / CURRENT CODES.
- (e) Read DTCs.

Result:

Display (DTC Output)	Proceed to
DTC P0AA6	A
DTCs P0AA6 and P0A1D (HV control ECU malfunction)	B
DTCs P0AA6 and P0A1F (Battery ECU malfunction)	C

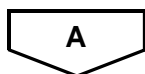
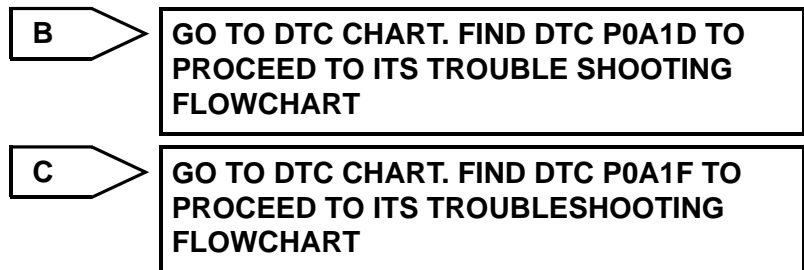

2	READ OUTPUT INF CODE
----------	-----------------------------

- (a) Connect the intelligent tester to the DLC3.
- (b) Turn the power switch ON (IG).
- (c) Turn the intelligent tester ON.
- (d) Enter the following menus: DIAGNOSIS / OBD/MOBD / HV ECU / DTC INFO / CURRENT CODES.
- (e) Display the freeze frame data for DTC P0AA6 and check its information (INF) code.

NOTICE:

If only INF code 526 is present, recheck INF code after waiting for 30 seconds with the power switch OFF.

Result:

Display (INF Code Output)	Proceed to
Only 526 (Insulation resistance of high voltage circuit and body is low)	A
526 and 611 (Insulation resistance of A/C area is low)	AC-134

HV

Display (INF Code Output)	Proceed to
526 and 612 (Insulation resistance of HV battery area is low)	B
526 and 613 (Insulation resistance of transaxle area is low)	C
526 and 614 (Insulation resistance of high voltage direct current area is low)	D

B → Go to step 5

C → Go to step 18

D → Go to step 19

A

3 CHECK ELECTRIC INVERTER COMPRESSOR

CAUTION:
Wear insulated gloves before performing the following operation.

- (a) Turn the power switch OFF.
- (b) Remove the service plug grip (see page HB-154).

NOTICE:

Turning the power switch ON (READY) with the service plug grip removed could cause malfunction. Therefore, never turn the power switch ON (READY) in this state.

- (c) Disconnect the C4 electric inverter compressor connector.
- (d) Using a megohmmeter, measure the insulation resistance between the high-voltage terminals of the electric inverter compressor connector and the body ground.

Standard resistance

Tester Connection	Specified Condition
C4-1 - Body ground	3.0 MΩ or higher
C4-2 - Body ground	3.0 MΩ or higher
C4-3 - Body ground	3.0 MΩ or higher

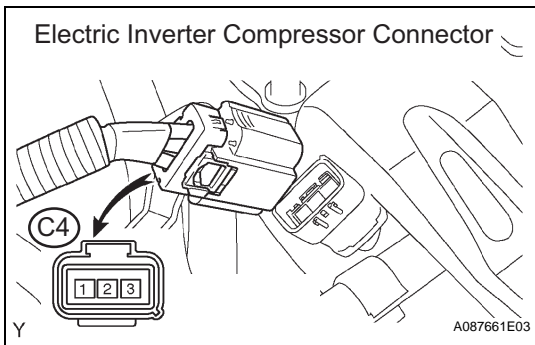

NG → REPLACE ELECTRIC INVERTER COMPRESSOR

OK

4 CHECK INSULATION RESISTANCE (INVERTER, TRANSAXLE AND FRAME WIRE)

CAUTION:
Wear insulated gloves before performing the following operation.

- (a) Check that the service plug grip has been detached.

HV

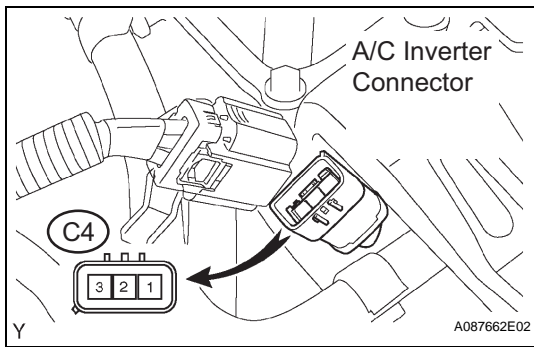

- (b) Check that the electric inverter compressor connector has been disconnected.
- (c) Using a megohmmeter, measure the insulation resistance between the high-voltage terminals of the A/C inverter connector and the body ground.

Standard resistance

Tester Connection	Specified Condition
C4-1 - Body ground	2.0 MΩ or higher
C4-2 - Body ground	2.0 MΩ or higher
C4-3 - Body ground	2.0 MΩ or higher

NG → Go to step 15

OK

5 CHECK HV BATTERY AREA

CAUTION:

Wear insulated gloves before performing the following operation.

- (a) Turn the power switch OFF.
- (b) Check that the service plug grip has been detached. If not, remove the service plug grip (see page [HB-154](#)).

NOTICE:

Turning the power switch ON (READY) with the service plug grip removed could cause malfunction. Therefore, never turn the power switch ON (READY) in this state.

- (c) Disconnect the B12 and B13 battery ECU connectors.

HV

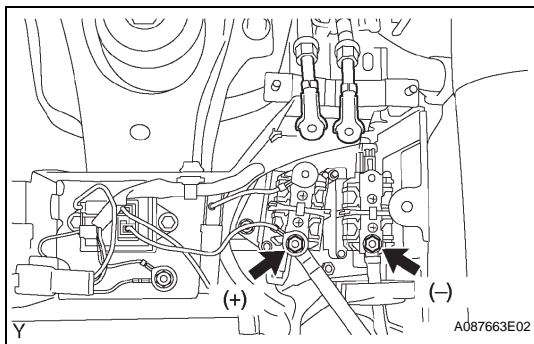
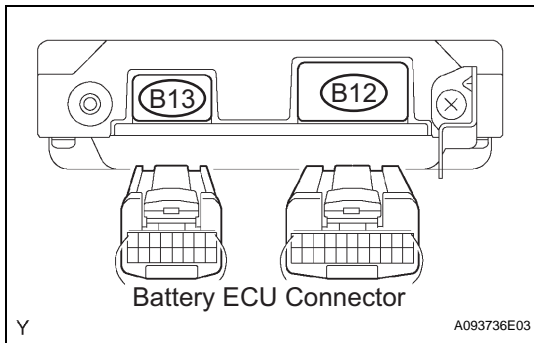

- (d) Disconnect the main battery cables from the system main relays.
- (e) Using a megohmmeter, measure the insulation resistance between the positive terminal on the HV battery side of the system main relay and the body ground.

Standard resistance:

10 MΩ or higher

- (f) Using a megohmmeter, measure the insulation resistance between the negative terminal on the HV battery side of the system main relay and the body ground.

Standard resistance:

10 MΩ or higher

OK

REPLACE BATTERY ECU ASSEMBLY

NG

6 CHECK SYSTEM MAIN RELAYS FOR STICKING**CAUTION:**

Wear insulated gloves before performing the following operation.

- Check that the service plug grip has been detached.
- Disconnect all the high-voltage terminals of the system main relays.
- Measure the resistance at the switch side of the system main relays.

Standard resistance:

Below 1 Ω

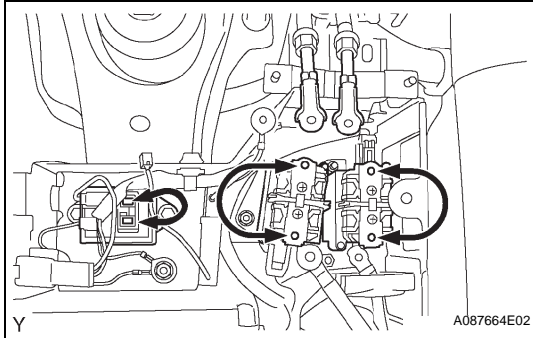

NG

GO TO "CHECK INSULATION RESISTANCE" PROCEDURE AFTER REPLACING STUCK SYSTEM MAIN RELAY

OK

7 CHECK SYSTEM MAIN RELAYS FOR INSULATION**CAUTION:**

Wear insulated gloves before performing the following operation.

- Check that the service plug grip has been detached.
- Check that all the high-voltage terminals of the system main relays have been disconnected.
- Using a megohmmeter, measure the insulation resistance between the high-voltage terminals of the system main relays and the body ground.

Standard resistance:

10 M Ω or higher

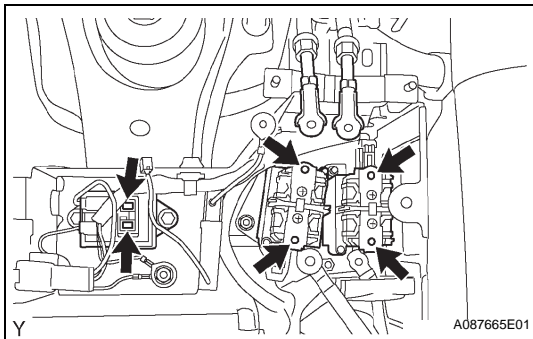

NG

REPLACE SYSTEM MAIN RELAY WITH REDUCED INSULATION RESISTANCE

OK

8 CHECK SYSTEM MAIN RESISTOR FOR INSULATION**CAUTION:**

Wear insulated gloves before performing the following operation.

- Check that the service plug grip has been detached.

HV

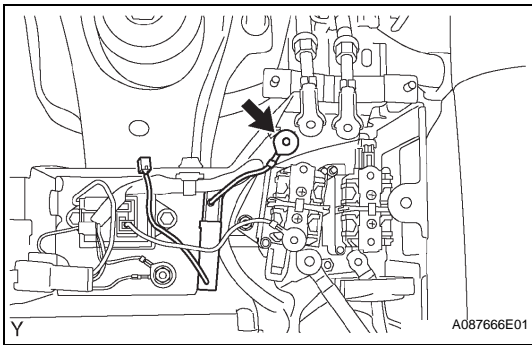

- (b) Check that both terminals of the system main resistor have been disconnected.
- (c) Using a megohmmeter, measure the insulation resistance between the high-voltage terminal of the system main resistor and the body ground.

Standard resistance:

10 MΩ or higher

NG

REPLACE SYSTEM MAIN RESISTOR

OK

9 INSPECT MAIN BATTERY CABLE

CAUTION:

Wear insulated gloves and goggles before performing the following operation.

- (a) Remove the HV battery assembly (see page [HB-92](#)).
- (b) Remove the battery cover (see page [HB-93](#)).
- (c) Check if the main battery cable cover is not damaged or internal electrical leads are not in contact with the battery case or body.

OK:

Electrical leads are not in contact with the battery case or body

- (d) Remove the terminal (A in the illustration) on the battery module side of the main battery cable only.
- (e) Using a megohmmeter, measure the insulation resistance between each terminal of the main battery cable and the shielded ground.

Standard resistance:

10 MΩ or higher

NG

REPLACE MAIN BATTERY CABLE

OK

10 INSPECT NO. 2 MAIN BATTERY CABLE

CAUTION:

Wear insulated gloves and goggles before performing the following operation.

- (a) Following the previous step, check if the No. 2 main battery cable cover is not damaged or internal electrical leads are not in contact with the battery case or body.

OK:

Electrical leads are not in contact with the battery case or body

- (b) Remove the terminal (A in illustration) on the battery module side of the No. 2 main battery cable only.
- (c) Using a megohmmeter, measure the insulation resistance between each terminal of the No. 2 main battery cable and the shielded ground.

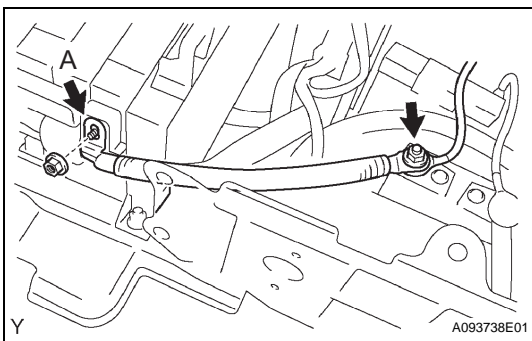
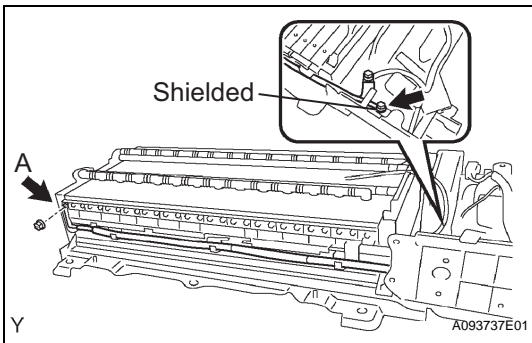

Standard resistance:
10 MΩ or higher

NG → REPLACE NO. 2 MAIN BATTERY CABLE

OK

11 INSPECT BATTERY PLUG

CAUTION:

Wear insulated gloves and goggles before performing the following operation.

- (a) Following the previous step, disconnect only the connecting terminal of the battery plug.

NOTICE:

Do not reinstall the service plug grip.

- (b) Using a megohmmeter, measure the insulation resistance between each terminal of the battery plug wire harness and body ground.

Standard resistance:
10 MΩ or higher

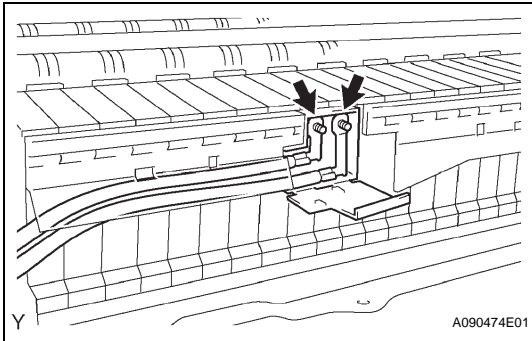

NG → REPLACE BATTERY PLUG

OK

12 INSPECT NO. 2 FRAME WIRE

CAUTION:

Wear insulated gloves and goggles before performing the following operation.

- (a) Following the previous step, check if the No. 2 frame wire cover is not damaged or internal electrical leads are not in contact with the battery case or body.

OK:

Electrical leads are not in contact with the battery case or body.

- (b) Remove all the terminals on the battery module side of the No. 2 frame wire.
- (c) Using a megohmmeter, measure the insulation resistance between each terminal of the No. 2 frame wire connector and the battery case.

Standard resistance:
10 MΩ or higher

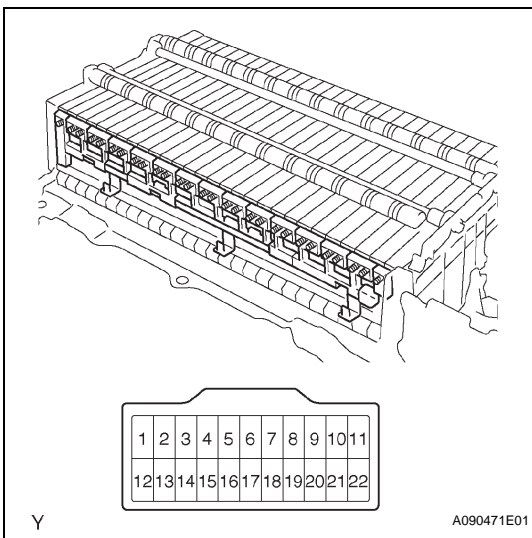

NG → REPLACE NO. 2 FRAME WIRE

OK

13 INSPECT JUNCTION BLOCK

CAUTION:

Wear insulated gloves and goggles before performing the following operation.

- (a) Following the previous step, remove the junction block.
- (b) Visually check the junction block for any damage.

OK:

No cracks or damage

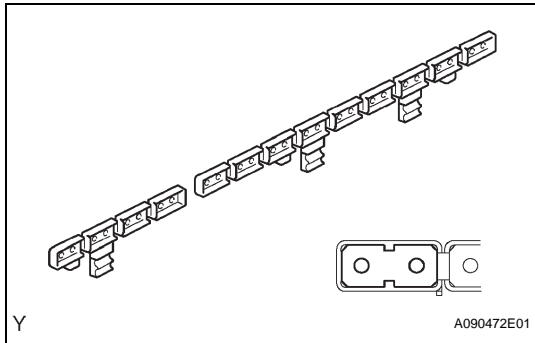

NG

REPLACE JUNCTION BLOCK

OK

14 INSPECT HV BATTERY ASSEMBLY

CAUTION:

Wear insulated gloves and goggles before performing the following operation.

- (a) Following the previous step, measure the insulation resistance between each terminal (positive and negative side) of each battery module of the HV battery assembly and the battery case using a megohmmeter.

Standard resistance:

Some of the battery modules have continuity of below 10 MΩ

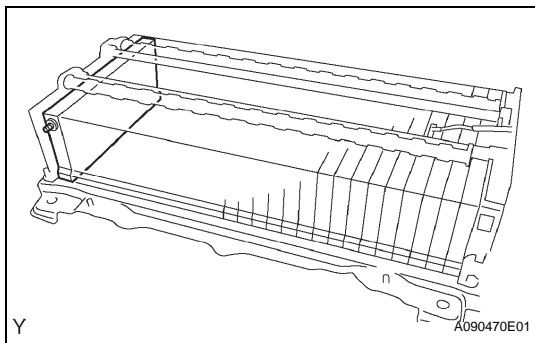

NG

REPLACE BATTERY ECU ASSEMBLY

OK

REPLACE HV SUPPLY BATTERY ASSEMBLY

15 CHECK SYSTEM MAIN RELAYS FOR STICKING

CAUTION:

Wear insulated gloves before performing the following operation.

- (a) Check that the service plug grip has been detached.

HV

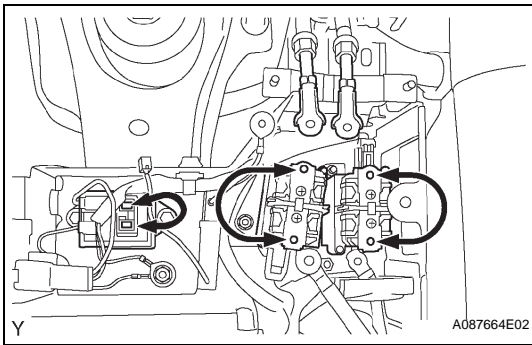

- (b) Disconnect all the high-voltage terminals of the system main relays.
- (c) Measure the resistance at the switch side of the system main relays.

Standard resistance:

Below 1 Ω

NG

GO TO "CHECK INSULATION RESISTANCE" PROCEDURE AFTER REPLACING STUCK SYSTEM MAIN RELAY

OK

16 CHECK FRAME WIRE FOR INSULATION

CAUTION:

Wear insulated gloves before performing the following operation.

- (a) Check that the service plug grip has been detached.
- (b) Disconnect the frame wire from the inverter.
- (c) Using a megohmmeter, measure the insulation resistance between the high-voltage terminals of the frame wire and the body ground.

Standard resistance:

10 M Ω or higher

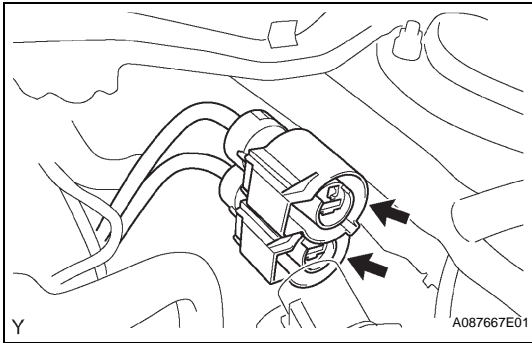

NG

REPLACE FRAME WIRE

OK

17 CHECK HV TRANSAXLE ASSEMBLY FOR INSULATION

CAUTION:

Wear insulated gloves before performing the following operation.

- (a) Check that the service plug grip has been detached.
- (b) Remove the inverter cover (see page [HV-531](#)).

HV

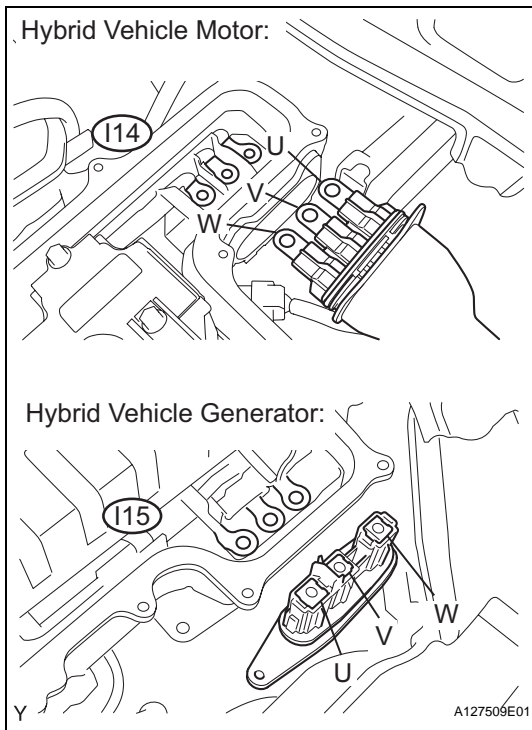

- (c) Disconnect the three-phase alternating current cables for the motor and generator from the inverter.
- (d) Using a megohmmeter, measure the insulation resistance between the 6 terminals of the three-phase alternating current cables on the transaxle side and the body ground.

Standard resistance

Tester Connection	Specified Condition
U (I14-1) - Body ground	10 MΩ or higher
V (I14-2) - Body ground	10 MΩ or higher
W (I14-3) - Body ground	10 MΩ or higher
U (I15-1) - Body ground	10 MΩ or higher
V (I15-2) - Body ground	10 MΩ or higher
W (I15-3) - Body ground	10 MΩ or higher

NG → **REPLACE HYBRID VEHICLE TRANSAXLE ASSEMBLY**

OK

REPLACE INVERTER WITH CONVERTER ASSEMBLY

18 CHECK HV TRANSAXLE AREA FOR INSULATION

HV

CAUTION:

Wear insulated gloves before performing the following operation.

- (a) Turn the power switch OFF.
- (b) Remove the service plug grip (see page [HB-154](#)).

NOTICE:

Turning the power switch ON (READY) with the service plug grip removed could cause malfunction. Therefore, never turn the power switch ON (READY) in this state.

- (c) Remove the inverter cover (see page [HV-531](#)).

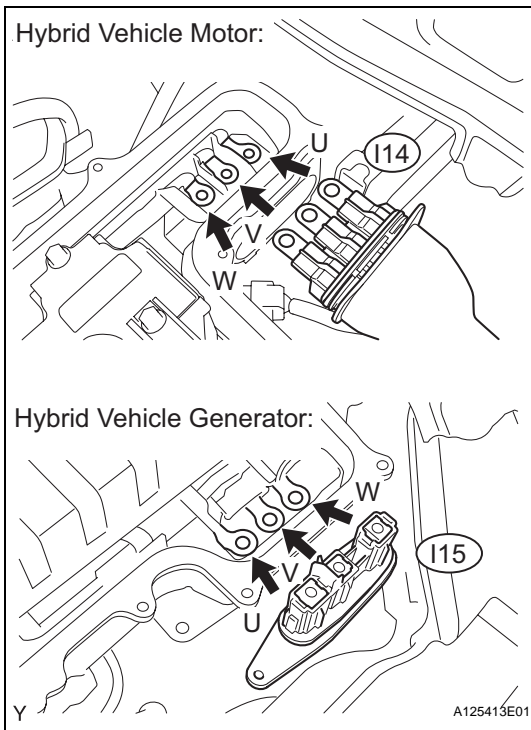

- (d) Disconnect the three-phase alternating current cables for the motor and generator from the inverter.
- (e) Using a megohmmeter, measure the insulation resistance between the 6 terminals of the three-phase alternating current cables on transaxle side and the body ground.

Standard resistance

Tester Connection	Specified Condition
U (I14-1) - Body ground	10 MΩ or higher
V (I14-2) - Body ground	10 MΩ or higher
W (I14-3) - Body ground	10 MΩ or higher
U (I15-1) - Body ground	10 MΩ or higher
V (I15-2) - Body ground	10 MΩ or higher
W (I15-3) - Body ground	10 MΩ or higher

OK → **REPLACE INVERTER WITH CONVERTER ASSEMBLY**

NG

REPLACE HYBRID VEHICLE TRANSAXLE ASSEMBLY

19 CHECK HIGH VOLTAGE DIRECT CURRENT AREA FOR INSULATION

CAUTION:

Wear insulated gloves before performing the following operation.

- (a) Turn the power switch OFF.
- (b) Remove the service plug grip (see page HB-154).

NOTICE:

Turning the power switch ON (READY) with the service plug grip removed could cause malfunction. Therefore, never turn the power switch ON (READY) in this state.

- (c) Disconnect the frame wire from the inverter.
- (d) Using a megohmmeter, measure the insulation resistance between the high-voltage terminals of the frame wire and the body ground.

Standard resistance:

10 MΩ or higher

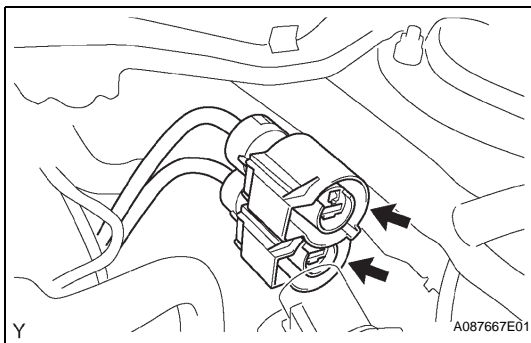

OK → **REPLACE INVERTER WITH CONVERTER ASSEMBLY**

NG

20 CHECK FRAME WIRE FOR INSULATION**CAUTION:**

Wear insulated gloves before performing the following operation.

- Check that the service plug grip has been detached.
- Disconnect the frame wire from the system main relays.
- Using a megohmmeter, measure the insulation resistance between the high-voltage terminals of the frame wire and the body ground.

Standard resistance:

10 M Ω or higher

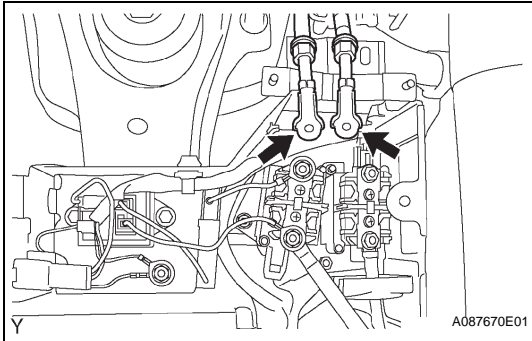

NG

REPLACE FRAME WIRE

OK

21 CHECK SYSTEM MAIN RELAYS FOR STICKING**CAUTION:**

Wear insulated gloves before performing the following operation.

- Check that the service plug grip has been detached.
- Disconnect all the high-voltage terminals of the system main relays.
- Measure the resistance at the switch side of the system main relays.

Standard resistance:

Below 1 Ω

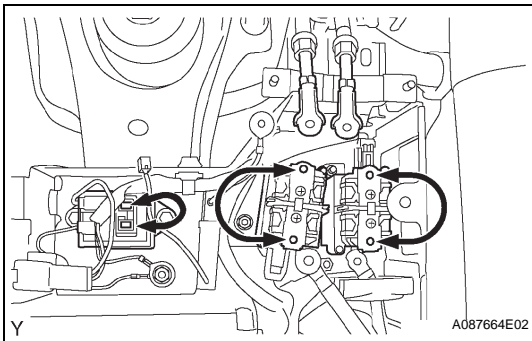

NG

GO TO "CHECK INSULATION RESISTANCE" PROCEDURE AFTER REPLACING STUCK SYSTEM MAIN RELAY

OK

22 CHECK SYSTEM MAIN RELAYS FOR INSULATION**CAUTION:**

Wear insulated gloves before performing the following operation.

- Check that the service plug grip has been detached.
- Check that all the high-voltage terminals of the system main relays have been disconnected.

HV

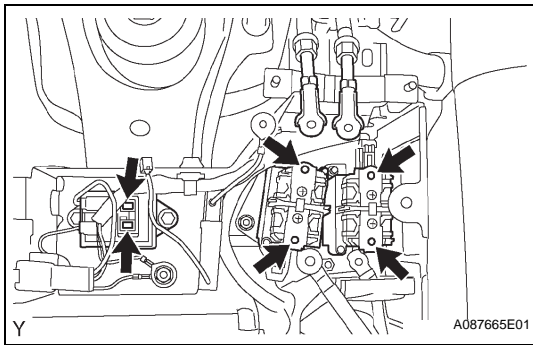

- (c) Using a megohmmeter, measure the insulation resistance between the high-voltage terminals of the system main relays and the body ground.
Standard resistance:
10 MΩ or higher

NG → **REPLACE SYSTEM MAIN RELAY WITH REDUCED INSULATION RESISTANCE**

OK

23 CHECK SYSTEM MAIN RESISTOR FOR INSULATION

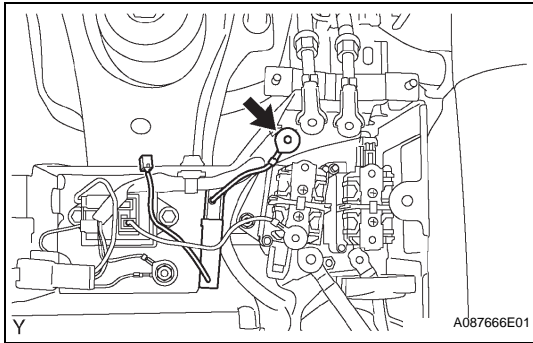

CAUTION:
Wear insulated gloves before performing the following operation.

- (a) Check that the service plug grip has been detached.
- (b) Check that both terminals of the system main resistor have been disconnected.
- (c) Using a megohmmeter, measure the insulation resistance between the high-voltage terminal of the system main resistor and the body ground.

Standard resistance:
10 MΩ or higher

NG → **REPLACE SYSTEM MAIN RESISTOR**

OK

24 INSPECT MAIN BATTERY CABLE

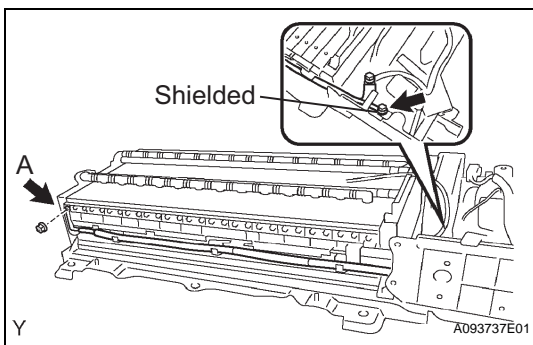

CAUTION:
Wear insulated gloves and goggles before performing the following operation.

- (a) Remove the HV battery assembly (see page [HB-92](#)).
- (b) Remove the battery cover (see page [HB-93](#)).
- (c) Check if the main battery cable cover is not damaged or internal electrical leads are not in contact with the battery case or body.

OK:
Electrical leads are not in contact with the battery case or body

- (d) Remove the terminal (A in the illustration) on the battery module side of the main battery cable only.
- (e) Using a megohmmeter, measure the insulation resistance between each terminal of the main battery cable and the shielded ground.

Standard resistance:
10 MΩ or higher

NG

REPLACE MAIN BATTERY CABLE

OK

25 INSPECT NO. 2 MAIN BATTERY CABLE

CAUTION:

Wear insulated gloves and goggles before performing the following operation.

- (a) Following the previous step, check if the No. 2 main battery cable cover is not damaged or internal electrical leads are not in contact with the battery case or body.

OK:

Electrical leads are not in contact with the battery case or body

- (b) Remove the terminal (A in illustration) on the battery module side of the No. 2 main battery cable only.
 (c) Using a megohmmeter, measure the insulation resistance between each terminal of the No. 2 main battery cable and the shielded ground.

Standard resistance:

10 M Ω or higher

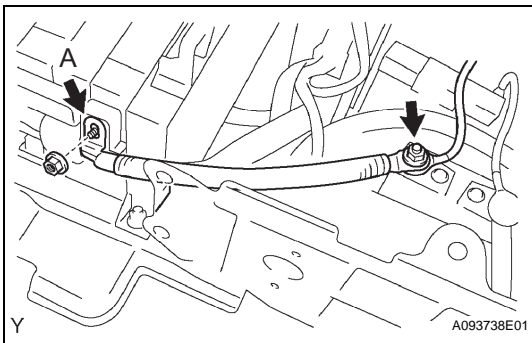

NG

REPLACE NO. 2 MAIN BATTERY CABLE

OK

26 INSPECT BATTERY PLUG

CAUTION:

Wear insulated gloves and goggles before performing the following operation.

- (a) Following the previous step, disconnect only the connecting terminal of the battery plug.

NOTICE:

Do not reinstall the service plug grip.

- (b) Using a megohmmeter, measure the insulation resistance between each terminal of the battery plug wire harness and the body ground.

Standard resistance:

10 M Ω or higher

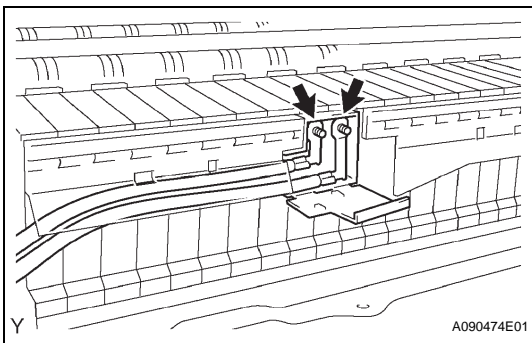

NG

REPLACE BATTERY PLUG

OK

27 INSPECT NO. 2 FRAME WIRE

CAUTION:

Wear insulated gloves and goggles before performing the following operation.

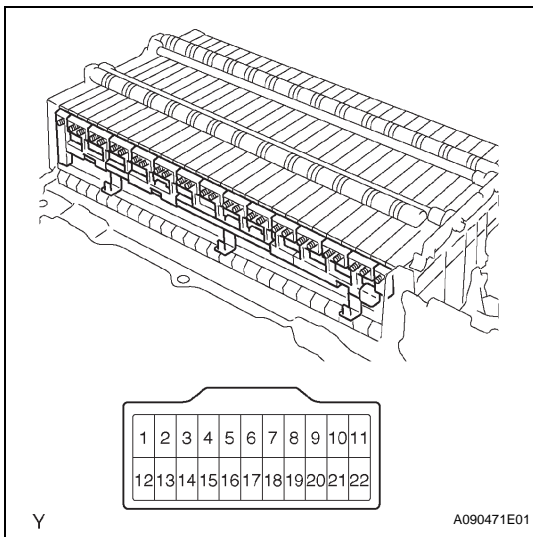

- (a) Following the previous step, check if the No. 2 frame wire cover is not damaged or internal electrical leads are not in contact with the battery case or body.

OK:

Electrical leads are not in contact with the battery case or body.

- (b) Remove all the terminals on the battery module side of the No. 2 frame wire.
- (c) Using a megohmmeter, measure the insulation resistance between each terminal of the No. 2 frame wire connector and the battery case.

Standard resistance:

10 MΩ or higher

NG → **REPLACE NO. 2 FRAME WIRE**

OK

28 INSPECT JUNCTION BLOCK

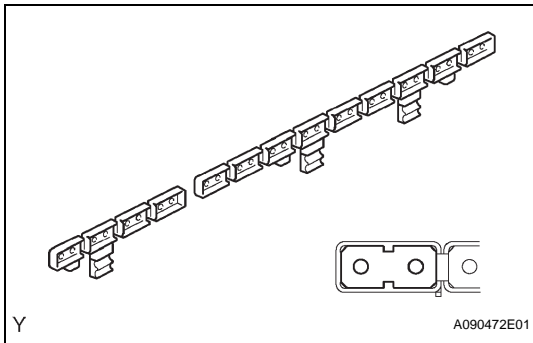

CAUTION:

Wear insulated gloves and goggles before performing the following operation.

- (a) Following the previous step, remove the junction block.
- (b) Visually check the junction block for any damage.

OK:

No cracks or damage

NG → **REPLACE JUNCTION BLOCK**

OK

29 INSPECT HV BATTERY ASSEMBLY

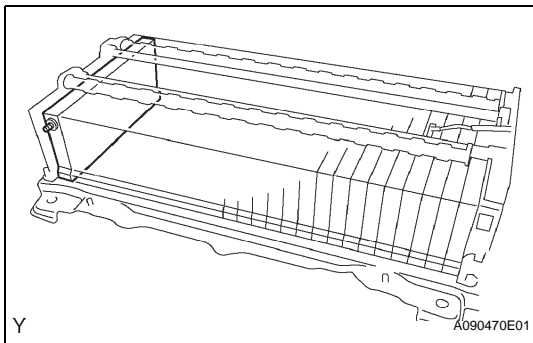

CAUTION:

Wear insulated gloves and goggles before performing the following operation.

- (a) Following the previous step, measure the insulation resistance between each terminal (positive and negative side) of each battery module of the HV battery assembly and the battery case using a megohmmeter.

Standard resistance:

Some of the battery modules have continuity of below 10 MΩ

NG → **REPLACE BATTERY ECU ASSEMBLY**

HV

OK

REPLACE HV SUPPLY BATTERY ASSEMBLY

DTC	P0ADC-226	Hybrid Battery Positive Contactor Control Circuit High
------------	------------------	---

DTC	P0ADB-227	Hybrid Battery Positive Contactor Control Circuit Low
------------	------------------	--

DESCRIPTION

Refer to DTC P0AE7 (INF 224) (see page [HV-444](#)).

The HV control ECU monitors the proper operation of the No. 2 system main relay (CON2) to check for a malfunction.

DTC No.	INF Code	DTC Detection Condition	Trouble Area
P0ADC	226	Open or +B short in No. 2 system main relay circuit	<ul style="list-style-type: none"> • Wire harness or connector • No. 2 system main relay • HV control ECU
P0ADB	227	GND short in No. 2 system main relay circuit	<ul style="list-style-type: none"> • Wire harness or connector • No. 2 system main relay • HV control ECU

WIRING DIAGRAM

Refer to DTC P0AE7 (INF 224) (see page [HV-445](#)).

INSPECTION PROCEDURE

CAUTION:

- Before inspecting the high-voltage system, take safety precautions to prevent electrical shocks, such as wearing insulated gloves and removing the service plug grip. After removing the service plug grip, put it in your pocket to prevent other technicians from reconnecting it while you are servicing the high-voltage system.
- After disconnecting the service plug grip, wait for at least 5 minutes before touching any of the high-voltage connectors or terminals.

HV

HINT:

At least 5 minutes are required to discharge the high-voltage condenser inside the inverter.

1	INSPECT NO. 2 SYSTEM MAIN RELAY
----------	--

- (a) Inspect the No. 2 system main relay (see page [HB-126](#)).

NG	REPLACE NO. 2 SYSTEM MAIN RELAY
-----------	--

OK

2	CHECK HARNESS AND CONNECTOR (HYBRID VEHICLE CONTROL ECU - NO. 2 SYSTEM MAIN RELAY)
----------	---

CAUTION:

Wear insulated gloves before performing the following operation.

- (a) Turn the power switch OFF.
- (b) Remove the service plug grip (see page [HB-154](#)).

NOTICE:

Turning the power switch ON (READY) with the service plug grip removed could cause malfunction. Therefore, never turn the power switch ON (READY) in this state.

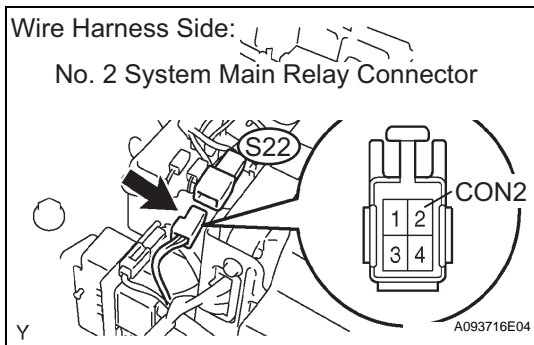
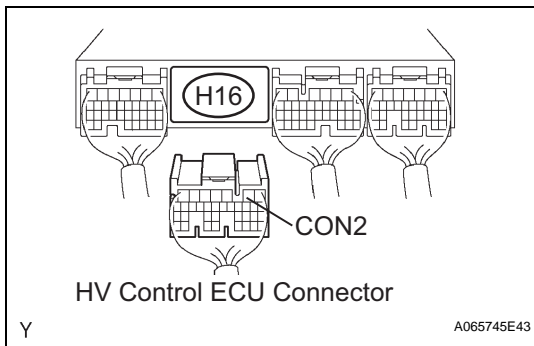

(c) Disconnect the H16 HV control ECU connector.

(d) Disconnect the S22 No. 2 system main relay connector.

(e) Turn the power switch ON (IG).

HINT:

DTCs for the interlock switch system are output when turning the power switch ON (IG) with the service plug grip removed.

(f) Measure the voltage between the terminal of the HV control ECU connector and body ground.

Standard voltage

Tester Connection	Specified Condition
CON2 (H16-2) - Body ground	Below 1 V

(g) Turn the power switch OFF.

(h) Measure the resistance between the wire harness side connectors.

Standard resistance (Check for open)

Tester Connection	Specified Condition
CON2 (H16-2) - CON2 (S22-2)	Below 1 Ω

Standard resistance (Check for short)

Tester Connection	Specified Condition
CON2 (H16-2) or CON2 (S22-2) - Body ground	10 kΩ or higher

(i) Reconnect the No. 2 system main relay connector.

(j) Reconnect the HV control ECU connector.

(k) Reinstall the service plug grip (see page [HB-154](#)).

NG → **REPAIR OR REPLACE HARNESS AND CONNECTOR**

OK

REPLACE HYBRID VEHICLE CONTROL ECU

HV

DTC	P0AE0-228	Hybrid Battery Negative Contactor Control Circuit High
DTC	P0ADF-229	Hybrid Battery Negative Contactor Control Circuit Low

DESCRIPTION

Refer to DTC P0AE7 (INF 224) (see page [HV-444](#)).

The HV control ECU monitors the proper operation of the No. 3 system main relay (CON3) to check for a malfunction.

DTC No.	INF Code	DTC Detection Condition	Trouble Area
P0AE0	228	Open or +B short in No. 3 system main relay circuit	<ul style="list-style-type: none"> Wire harness or connector No. 3 system main relay HV control ECU
P0ADF	229	GND short in No. 3 system main relay circuit	<ul style="list-style-type: none"> Wire harness or connector No. 3 system main relay HV control ECU

MONITOR DESCRIPTION

DTC P0AE0 (INF 228):

The HV control ECU monitors the proper operation of the No. 3 system main relay (CON3). If the HV control ECU detects an open or short malfunction of the relay circuit, the HV control ECU illuminates the MIL and sets a DTC.

MONITOR STRATEGY

Related DTCs	P0AE0 (INF 228): Rationality (cont3 malfunction)
Required sensor / components	No. 3 system main relay
Frequency of operation	Continuous
Duration	TOYOTA's intellectual property
MIL operation	1 driving cycle
Sequence of operation	None

HV

TYPICAL ENABLING CONDITIONS

The monitor will run whenever the following DTCs are not present	TOYOTA's intellectual property
Other conditions belong to TOYOTA's intellectual property	-

TYPICAL MALFUNCTION THRESHOLDS

No. 3 system main relay circuit	Short
---------------------------------	-------

COMPONENT OPERATING RANGE

No. 3 system main relay	DTC P0AE0 (INF 228) is not detected
-------------------------	-------------------------------------

WIRING DIAGRAM

Refer to DTC P0AE7 (INF 224) (see page [HV-445](#)).

INSPECTION PROCEDURE

CAUTION:

- Before inspecting the high-voltage system, take safety precautions to prevent electrical shocks, such as wearing insulated gloves and removing the service plug grip. After removing the service plug grip, put it in your pocket to prevent other technicians from reconnecting it while you are servicing the high-voltage system.
- After disconnecting the service plug grip, wait for at least 5 minutes before touching any of the high-voltage connectors or terminals.

HINT:

At least 5 minutes are required to discharge the high-voltage condenser inside the inverter.

1 INSPECT NO. 3 SYSTEM MAIN RELAY

- (a) Inspect the No. 3 system main relay (see page [HB-126](#)).

NG → **REPLACE NO. 3 SYSTEM MAIN RELAY**

OK

2 CHECK HARNESS AND CONNECTOR (HYBRID VEHICLE CONTROL ECU - NO. 3 SYSTEM MAIN RELAY)

CAUTION:

Wear insulated gloves before performing the following operation.

- (a) Turn the power switch OFF.
 (b) Remove the service plug grip (see page [HB-154](#)).

NOTICE:

Turning the power switch ON (READY) with the service plug grip removed could cause malfunction. Therefore, never turn the power switch ON (READY) in this state.

- (c) Disconnect the H16 HV control ECU connector.

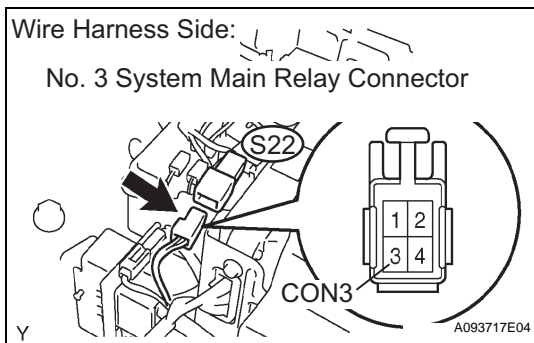
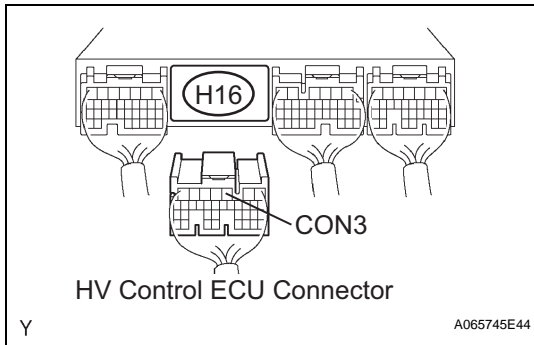

- (d) Disconnect the S22 No. 3 system main relay connector.
 (e) Turn the power switch ON (IG).

HINT:

DTCs for the interlock switch system are output when turning the power switch ON (IG) with the service plug grip removed.

- (f) Measure the voltage between the terminal of the HV control ECU connector and body ground.

Standard voltage

Tester Connection	Specified Condition
CON3 (H16-3) - Body ground	Below 1 V

- (g) Turn the power switch OFF.
- (h) Measure the resistance between the wire harness side connectors.

Standard resistance (Check for open)

Tester Connection	Specified Condition
CON3 (H16-3) - CON3 (S22-3)	Below 1 Ω

Standard resistance (Check for short)

Specified Connection	Specified Condition
CON3 (H16-3) or CON3 (S22-3) - Body ground	10 k Ω or higher

- (i) Reconnect the No. 3 system main relay connector.
- (j) Reconnect the HV control ECU connector.
- (k) Reinstall the service plug grip (see page [HB-154](#)).

NG**REPAIR OR REPLACE HARNESS OR CONNECTOR****OK****REPLACE HYBRID VEHICLE CONTROL ECU**

DTC	P0AE7-224	Hybrid Battery Precharge Contactor Control Circuit High
------------	------------------	--

DTC	P0AE6-225	Hybrid Battery Precharge Contactor Control Circuit Low
------------	------------------	---

DESCRIPTION

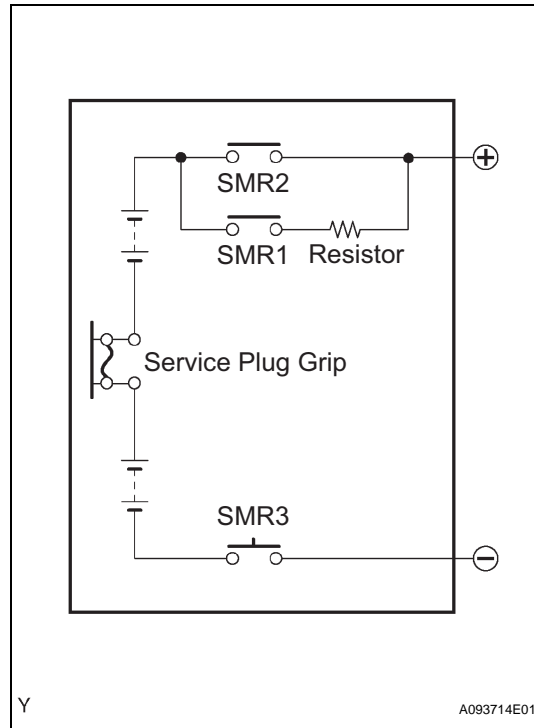

HV

The SMRs (System Main Relays) connect and disconnect the high-voltage power supply circuit in accordance with requests from the HV control ECU. To ensure a reliable operation, they consist of a total of 3 relays (1 for the negative side and 2 for the positive side).

To connect, SMR1 and SMR3 turn ON initially. Then, SMR2 turns ON and SMR1 turns OFF. This process protects the circuit from the high-voltage surge current by allowing the limit current to flow via the resistor. To disconnect, SMR2 and SMR3 turn OFF in that order. The HV control ECU checks that the relays have turned OFF properly.

The HV control ECU monitors the proper operation of the SMRs (CON1, CON2 and CON3) to check for a malfunction.

DTC No.	INF Code	DTC Detection Condition	Trouble Area
P0AE7	224	Open or +B short in No. 1 system main relay circuit	<ul style="list-style-type: none"> Wire harness or connector No. 1 system main relay HV control ECU
P0AE6	225	GND short in No. 1 system main relay circuit	<ul style="list-style-type: none"> Wire harness or connector No. 1 system main relay HV control ECU

WIRING DIAGRAM

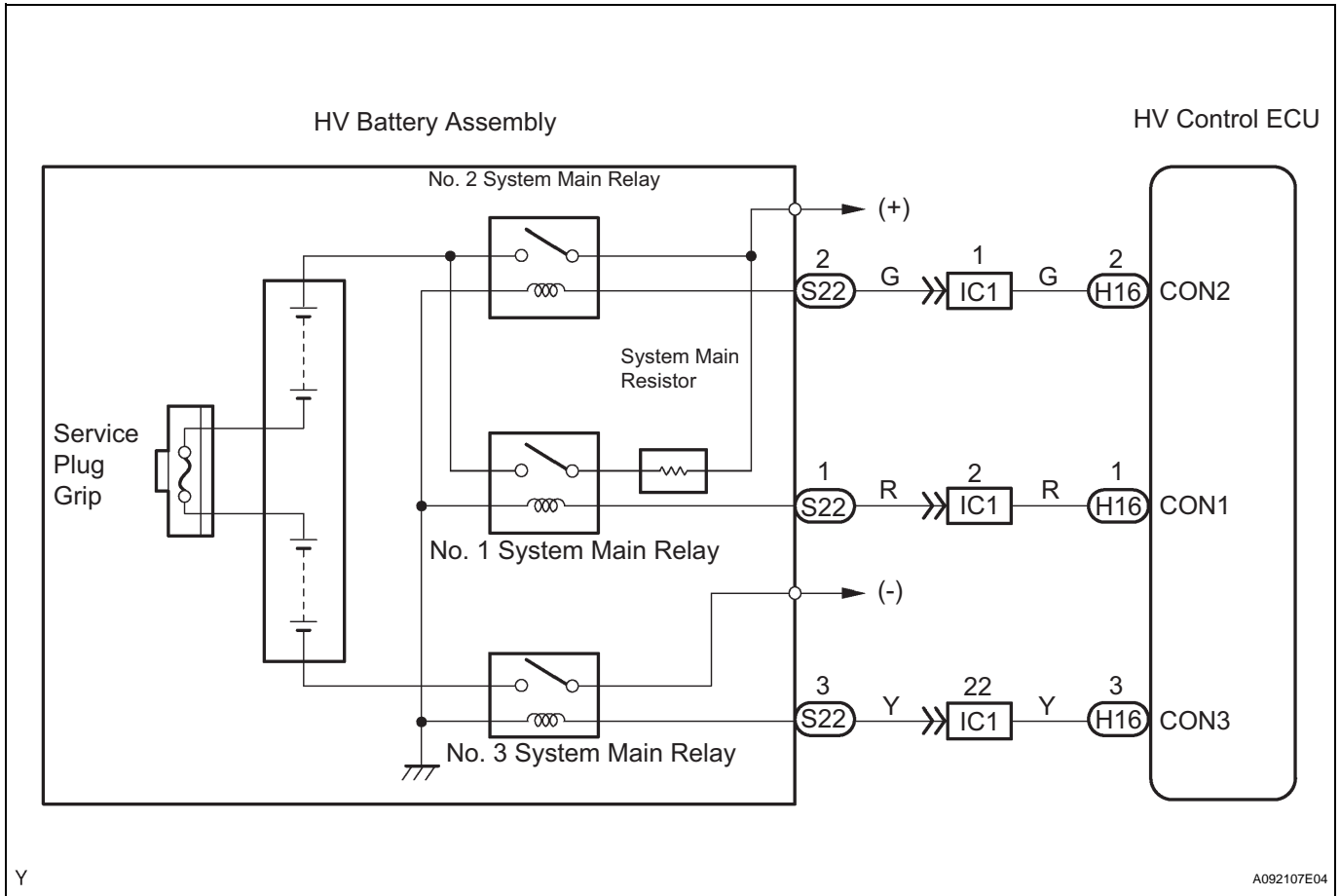

INSPECTION PROCEDURE

CAUTION:

- Before inspecting the high-voltage system, take safety precautions to prevent electrical shocks, such as wearing insulated gloves and removing the service plug grip. After removing the service plug grip, put it in your pocket to prevent other technicians from reconnecting it while you are servicing the high-voltage system.
- After disconnecting the service plug grip, wait for at least 5 minutes before touching any of the high-voltage connectors or terminals.

HINT:

At least 5 minutes are required to discharge the high-voltage condenser inside the inverter.

1 INSPECT NO. 1 SYSTEM MAIN RELAY

(a) Inspect the No. 1 system main relay (see page [HB-124](#)).

NG → **REPLACE NO. 1 SYSTEM MAIN RELAY**

OK

2 CHECK HARNESS AND CONNECTOR (HYBRID VEHICLE CONTROL ECU - NO. 1 SYSTEM MAIN RELAY)

CAUTION:

Wear insulated gloves before performing the following operation.

- (a) Turn the power switch OFF.
- (b) Remove the service plug grip (see page [HB-154](#)).

NOTICE:

Turning the power switch ON (READY) with the service plug grip removed could cause malfunction. Therefore, never turn the power switch ON (READY) in this state.

- (c) Disconnect the H16 HV control ECU connector.

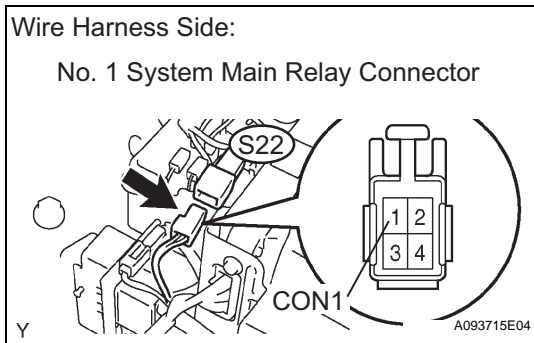
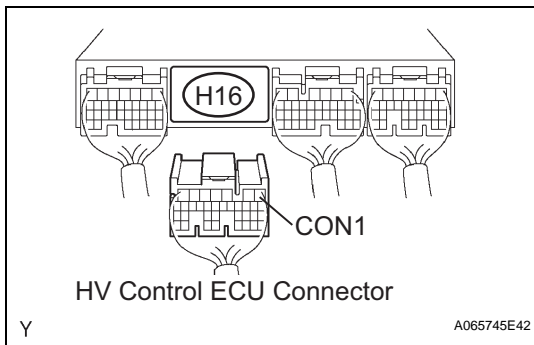

- (d) Disconnect the S22 No. 1 system main relay connector.
- (e) Turn the power switch ON (IG).

HINT:

DTCs for the interlock switch system are output when turning the power switch ON (IG) with the service plug grip removed.

- (f) Measure the voltage between the terminal of the HV control ECU connector and body ground.

Standard voltage

Tester Connection	Specified Condition
CON1 (H16-1) - Body ground	Below 1 V

- (g) Turn the power switch OFF.
- (h) Measure the resistance between the wire harness side connectors.

Standard resistance (Check for open)

Tester Connection	Specified Condition
CON1 (H16-1) - CON1 (S22-1)	Below 1 Ω

Standard resistance (Check for short)

Tester Connection	Specified Condition
CON1 (H16-1) or CON1 (S22-1) - Body ground	10 kΩ or higher

- (i) Reconnect the No. 1 system main relay connector.
- (j) Reconnect the HV control ECU connector.
- (k) Reinstall the service plug grip (see page [HB-154](#)).

NG **REPAIR OR REPLACE HARNESS OR CONNECTOR**

HV

OK

REPLACE HYBRID VEHICLE CONTROL ECU

DTC	P0AEE-276	Motor Inverter Temperature Sensor "A" Circuit Range / Performance
------------	------------------	--

DTC	P0AEE-277	Motor Inverter Temperature Sensor "A" Circuit Range / Performance
------------	------------------	--

DESCRIPTION

Refer to DTC P0AEF (INF 275) (see page HV-453).

DTC No.	INF Code	DTC Detection Condition	Trouble Area
P0AEE	276	Sudden change in motor inverter temperature sensor output	<ul style="list-style-type: none"> • Wire harness or connector • Inverter cooling system • Water pump with motor assembly • Cooling fan motor • No. 2 cooling fan motor • Inverter with converter assembly
P0AEE	277	Motor inverter temperature sensor output deviation	<ul style="list-style-type: none"> • Wire harness or connector • Inverter cooling system • Water pump with motor assembly • Cooling fan motor • No. 2 cooling fan motor • Inverter with converter assembly

WIRING DIAGRAM

Refer to DTC P0AEF (INF 275) (see page HV-453).

INSPECTION PROCEDURE

HV

CAUTION:

- Before inspecting the high-voltage system, take safety precautions to prevent electrical shocks, such as wearing insulated gloves and removing the service plug grip. After removing the service plug grip, put it in your pocket to prevent other technicians from reconnecting it while you are servicing the high-voltage system.
- After disconnecting the service plug grip, wait for at least 5 minutes before touching any of the high-voltage connectors or terminals.

HINT:

At least 5 minutes are required to discharge the high-voltage condenser inside the inverter.

1	CHECK QUANTITY OF HV COOLANT
----------	-------------------------------------

- (a) Check that there is a sufficient amount of coolant for the inverter.

OK:

There is a sufficient amount of coolant for the inverter

NG	ADD HV COOLANT
-----------	-----------------------

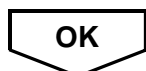

2 CHECK COOLANT HOSE

- (a) Check that the hoses of the cooling system are not bent or clogged (refer to the cooling system [see page [HV-453](#)]).

OK:

The hoses of the cooling system are not bent or clogged

NG

CORRECT TO NORMAL CONDITION

OK

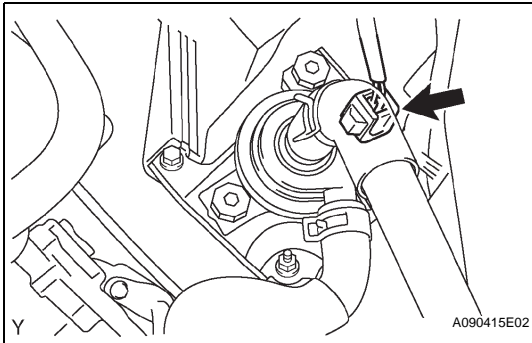
3 CHECK CONNECTION CONDITION OF WATER PUMP CONNECTOR (LOOSENESS AND POOR CONTACT)

- (a) Check the connection condition of the water pump connector.

OK:

Connector has been connected securely and there is no poor connection.

NG

CONNECT SECURELY

OK

4 CHECK WATER PUMP WITH MOTOR ASSEMBLY

- (a) Turn the power switch ON (IG).
(b) Check the operation of the water pump.

OK:

Coolant is sloshing in the reservoir tank

NG

REPLACE WATER PUMP WITH MOTOR ASSEMBLY

OK

5 CHECK CONNECTION CONDITION OF COOLING FAN MOTOR CONNECTOR (LOOSENESS AND POOR CONTACT)

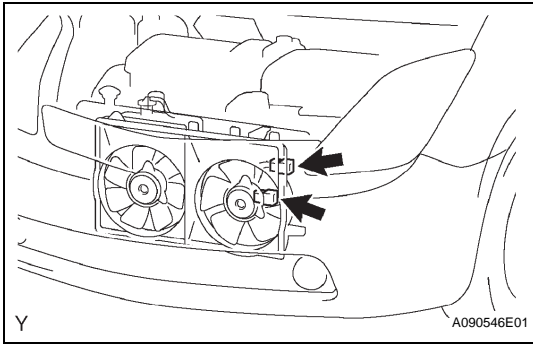

(a) Check the connection condition of the cooling fan motor connectors.

OK:

Connectors have been connected securely and there is no poor connection.

NG → **CONNECT SECURELY**

OK

6 INSPECT COOLING FAN MOTOR

(a) Inspect the cooling fan motor (see page [CO-5](#)).

NG → **REPLACE COOLING FAN MOTOR AND ADD ENGINE COOLANT**

OK

7 INSPECT NO. 2 COOLING FAN MOTOR

(a) Inspect the No. 2 cooling fan motor (see page [CO-5](#)).

NG → **REPLACE NO. 2 COOLING FAN MOTOR AND ADD ENGINE COOLANT**

OK

8 CHECK CONNECTION CONDITION OF HYBRID VEHICLE CONTROL ECU CONNECTOR (LOOSENESS AND POOR CONTACT)

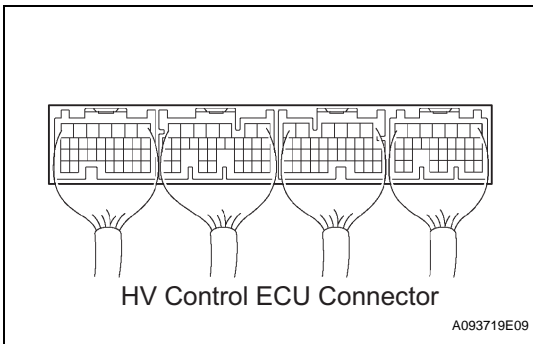

(a) Check the connection condition of all the connectors at the HV control ECU.

OK:

Connectors have been connected securely and there is no poor connection.

NG → **CONNECT SECURELY**

OK

HV

9 CHECK CONNECTION CONDITION OF INVERTER CONNECTOR (LOOSENESS AND POOR CONTACT)

CAUTION:

Wear insulated gloves before performing the following operation.

- Turn the power switch OFF.
- Remove the service plug grip (see page [HB-154](#)).

NOTICE:

Turning the power switch ON (READY) with the service plug grip removed could cause malfunction. Therefore, never turn the power switch ON (READY) in this state.

- Remove the inverter cover (see page [HV-531](#)).
- Check the connection condition of the I9 and I10 inverter connectors.

OK:

Connectors have been connected securely and there is no poor connection.

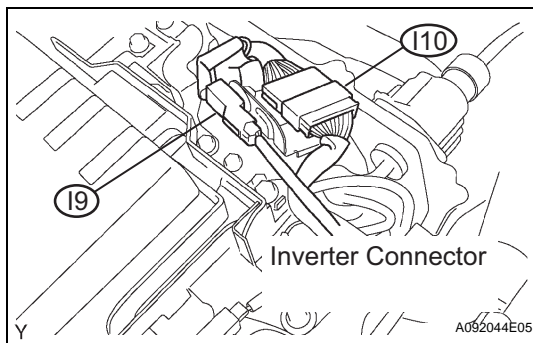

OK

NG

CONNECT SECURELY

10 CHECK HARNESS AND CONNECTOR (HYBRID VEHICLE CONTROL ECU - INVERTER)

CAUTION:

Wear insulated gloves before performing the following operation.

- Check that the service plug grip and inverter cover have been removed.
- Disconnect the H15 HV control ECU connector.

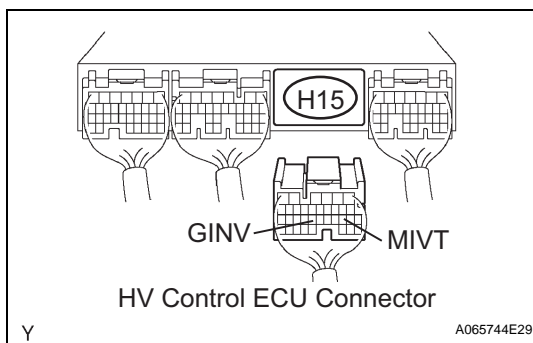

HV

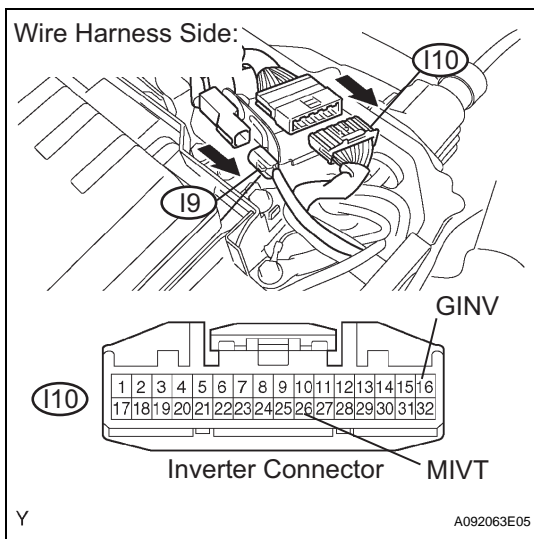

- (c) Disconnect the I9 and I10 inverter connectors.
- (d) Turn the power switch ON (IG).
HINT:
DTCs for the interlock switch system are output when turning the power switch ON (IG) with both service plug grip and inverter cover removed.
- (e) Measure the voltage between the terminals of the HV control ECU connector and body ground.

Standard voltage

Tester Connection	Specified Condition
MIVT (H15-19) - Body ground	Below 1 V
GINV (H15-23) - Body ground	Below 1 V

- (f) Turn the power switch OFF.
- (g) Measure the resistance between the wire harness side connectors.

Standard resistance (Check for open)

Tester Connection	Specified Condition
MIVT (H15-19) - MIVT (I10-26)	Below 1 Ω
GINV (H15-23) - GINV (I10-16)	Below 1 Ω

Standard resistance (Check for short)

Tester Connection	Specified Condition
MIVT (H15-19) or MIVT (I10-26) - Body ground	10 kΩ or higher
GINV (H15-23) or GINV (I10-16) - Body ground	10 kΩ or higher

- (h) Reconnect the inverter connectors.
- (i) Reconnect the HV control ECU connector.
- (j) Reinstall the inverter cover (see page HV-538).
- (k) Reinstall the service plug grip (see page HB-154).

NG → **REPAIR OR REPLACE HARNESS OR CONNECTOR**

OK

REPLACE INVERTER WITH CONVERTER ASSEMBLY

HV

DTC	P0AEF-275	Drive Motor Inverter Temperature Sensor "A" Circuit Low
------------	------------------	--

DTC	P0AF0-274	Drive Motor Inverter Temperature Sensor "A" Circuit High
------------	------------------	---

DESCRIPTION

The HV control ECU uses a temperature sensor, which is built into the inverter, to detect the temperature of the motor inverter. The same cooling system that is routed to the MG1 and MG2 cools the inverter. This cooling system is independent from the engine cooling system.

The characteristic of the motor inverter temperature sensor is the same as the boost converter temperature sensor (see page HV-395).

The HV control ECU limits the load based on the signals transmitted by the motor inverter temperature sensor, in order to check the effectiveness of the inverter cooling system and prevent the inverter from overheating. Furthermore, the HV control ECU detects a malfunction in the wiring of the motor inverter temperature sensor, as well as in the sensor itself.

DTC No.	INF Code	DTC Detection Condition	Trouble Area
P0AEF	275	Open or GND short in motor inverter temperature sensor circuit	<ul style="list-style-type: none"> Wire harness or connector Inverter with converter assembly HV control ECU
P0AF0	274	+B short in motor inverter temperature sensor circuit	<ul style="list-style-type: none"> Wire harness or connector Inverter with converter assembly HV control ECU

HINT:

After confirming DTC P0AEF (INF 275) or P0AF0 (INF 274), confirm MG2 INVERT TEMP in DIAGNOSIS / OBD/MOBD / HV ECU / DATA LIST using the intelligent tester.

Temperature Displayed	Malfunction
-50°C (-58°F)	+B short circuit
205°C (401°F)	Open or GND short circuit

HV

WIRING DIAGRAM

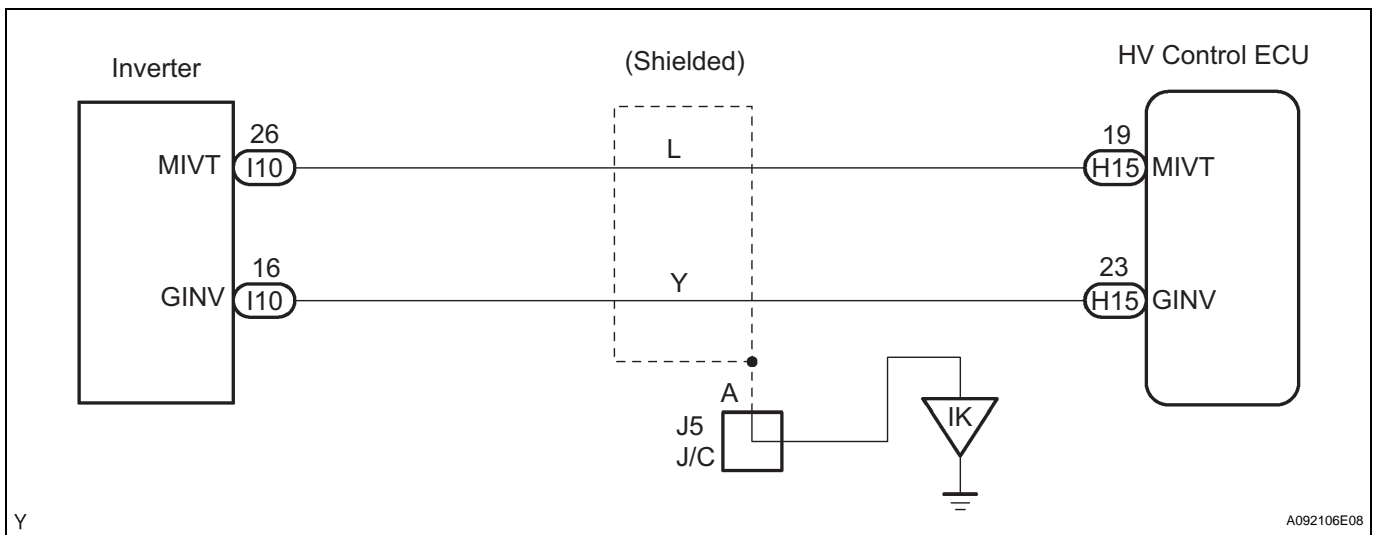

Y

A092106E08

INSPECTION PROCEDURE

CAUTION:

- Before inspecting the high-voltage system, take safety precautions to prevent electrical shocks, such as wearing insulated gloves and removing the service plug grip. After removing the service plug grip, put it in your pocket to prevent other technicians from reconnecting it while you are servicing the high-voltage system.
- After disconnecting the service plug grip, wait for at least 5 minutes before touching any of the high-voltage connectors or terminals.

HINT:

At least 5 minutes are required to discharge the high-voltage condenser inside the inverter.

1	READ VALUE OF INTELLIGENT TESTER (MG2 INVERT TEMP)
----------	---

- (a) Connect the intelligent tester to the DLC3.
- (b) Turn the power switch ON (IG).
- (c) Turn the intelligent tester ON.
- (d) Enter the following menus: DIAGNOSIS / OBD/MOBD / HV ECU / DATA LIST.
- (e) Read the MG2 INVERT TEMP value.

Result:

Temperature Displayed	Proceed to
-50°C (-58°F)	A
205°C (401°F)	B
-49°C to 204°C (-57°F to 400°F)	C

HINT:

- If there is a +B short circuit, the intelligent tester indicates -50°C (-58°F).
- If there is an open or GND short circuit, the intelligent tester indicates 205°C (401°F).

HV

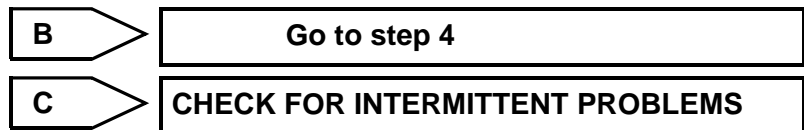

2	READ VALUE OF INTELLIGENT TESTER (CHECK FOR +B SHORT IN WIRE HARNESS)
----------	--

CAUTION:

Wear insulated gloves before performing the following operation.

- (a) Turn the power switch OFF.
- (b) Remove the service plug grip (see page [HB-154](#)).

NOTICE:

Turning the power switch ON (READY) with the service plug grip removed could cause malfunction. Therefore, never turn the power switch ON (READY) in this state.

- (c) Remove the inverter cover (see page [HV-531](#)).

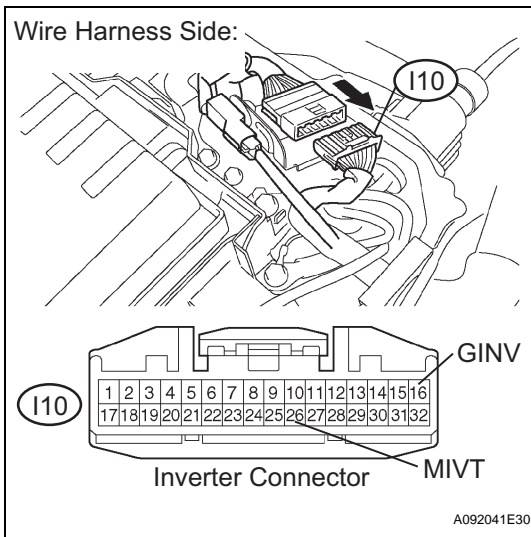

(d) Disconnect the I10 inverter connector.

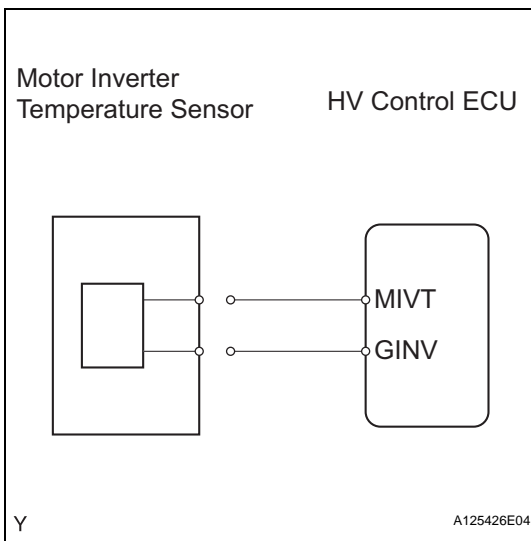

(e) Turn the power switch ON (IG).

HINT:

DTCs for the interlock switch system are output when turning the power switch ON (IG) with both service plug grip and inverter cover removed.

(f) Enter the following menus: DIAGNOSIS / OBD/MOBD / HV ECU / DATA LIST.

(g) Read the MG2 INVERT TEMP value.

OK:

205°C (401°F)

(h) Turn the power switch OFF.

(i) Reconnect the inverter connector.

(j) Reinstall the inverter cover (see page [HV-538](#)).

(k) Reinstall the service plug grip (see page [HB-154](#)).

OK

REPLACE INVERTER WITH CONVERTER ASSEMBLY

HV

NG

3 READ VALUE OF INTELLIGENT TESTER (CHECK FOR +B SHORT IN HYBRID VEHICLE CONTROL ECU)

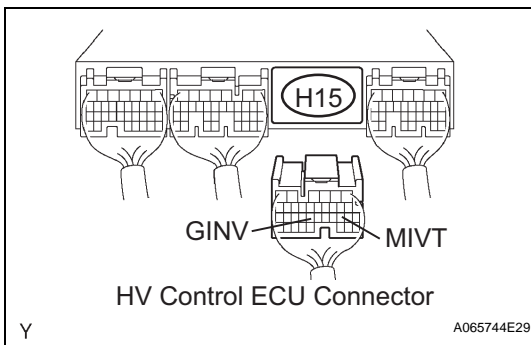

(a) Disconnect the H15 HV control ECU connector.

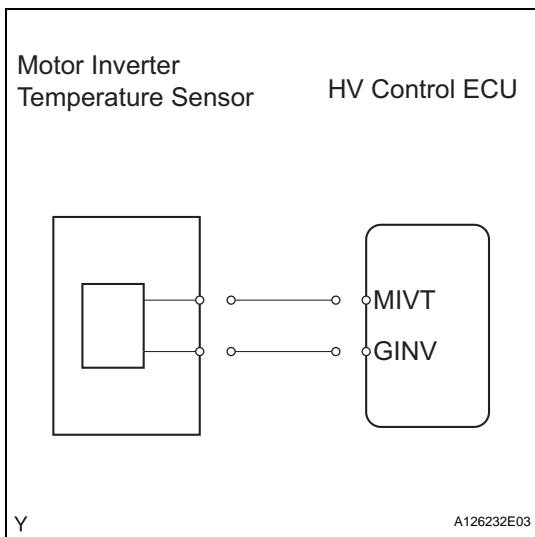

- (b) Turn the power switch ON (IG).
HINT:
DTCs for the interlock switch system are output when turning the power switch ON (IG) with both service plug grip and inverter cover removed.
- (c) Enter the following menus: DIAGNOSIS / OBD/MOBD / HV ECU / DATA LIST.
- (d) Read the MG2 INVERT TEMP value.
OK:
205°C (401°F)
- (e) Reconnect the HV control ECU connector.

NG → **REPLACE HYBRID VEHICLE CONTROL ECU**

OK

REPAIR OR REPLACE HARNESS OR CONNECTOR

4 CHECK HARNESS AND CONNECTOR (HYBRID VEHICLE CONTROL ECU - INVERTER)

CAUTION:
Wear insulated gloves before performing the following operation.

- (a) Turn the power switch OFF.
- (b) Remove the service plug grip (see page [HB-154](#)).

NOTICE:
Turning the power switch ON (READY) with the service plug grip removed could cause malfunction. Therefore, never turn the power switch ON (READY) in this state.

- (c) Remove the inverter cover (see page [HV-531](#)).
- (d) Disconnect the H15 HV control ECU connector.

HV

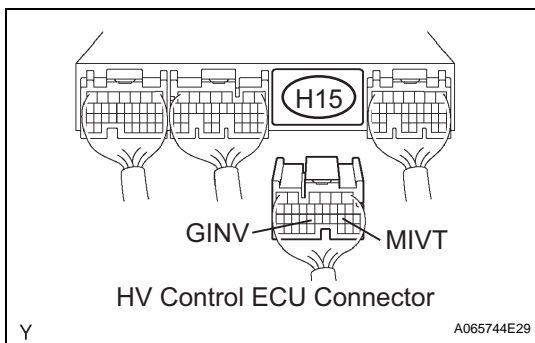

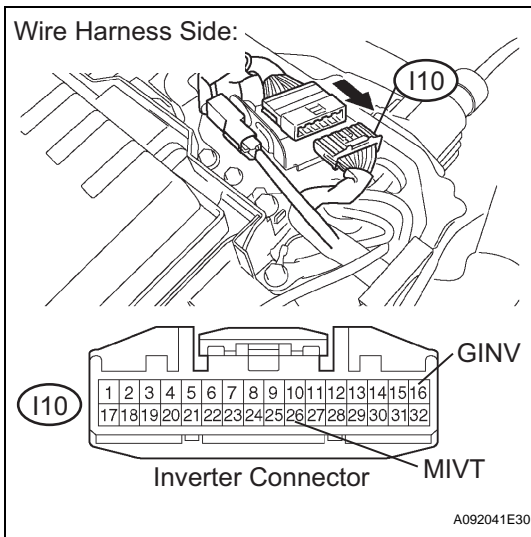

- (e) Disconnect the I10 inverter connector.
- (f) Measure the resistance between the wire harness side connectors.

Standard resistance (Check for open)

Tester Connection	Specified Condition
MIVT (H15-19) - MIVT (I10-26)	Below 1 Ω
GINV (H15-23) - GINV (I10-16)	Below 1 Ω

Standard resistance (Check for short)

Tester Connection	Specified Condition
MIVT (H15-19) or MIVT (I10-26) - Body ground	10 kΩ or higher
GINV (H15-23) or GINV (I10-16) - Body ground	10 kΩ or higher

- (g) Reconnect the inverter connector.
- (h) Reconnect the HV control ECU connector.
- (i) Reinstall the inverter cover (see page HV-538).
- (j) Reinstall the service plug grip (see page HB-154).

NG → REPAIR OR REPLACE HARNESS OR CONNECTOR

OK

5 INSPECT HYBRID VEHICLE CONTROL ECU (MIVT VOLTAGE)

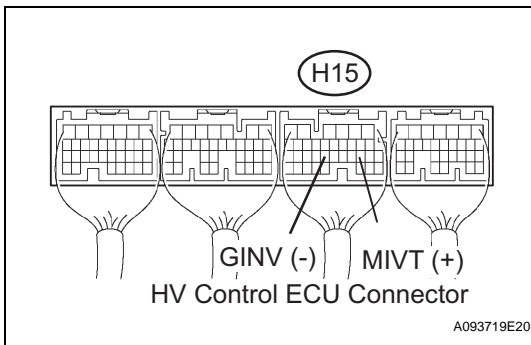

- (a) Turn the power switch ON (IG).
HINT:
DTCs for the interlock switch system are output when turning the power switch ON (IG) with both service plug grip and inverter cover removed.
- (b) Measure the voltage between the terminals of the H15 HV control ECU connector.

Standard voltage

Tester Connection	Specified Condition
MIVT (H15-19) - GINV (H15-23)	2.0 to 4.5 V

NG → REPLACE INVERTER WITH CONVERTER ASSEMBLY

OK

REPLACE HYBRID VEHICLE CONTROL ECU

HV

DTC	P2120-111	Throttle / Pedal Position Sensor / Switch "D" Circuit
DTC	P2121-106	Throttle / Pedal Position Sensor / Switch "D" Circuit Range / Performance
DTC	P2121-114	Throttle / Pedal Position Sensor / Switch "D" Circuit Range / Performance
DTC	P2125-112	Throttle / Pedal Position Sensor / Switch "E" Circuit
DTC	P2126-109	Throttle / Pedal Position Sensor / Switch "E" Circuit Range / Performance
DTC	P2138-110	Throttle / Pedal Position Sensor / Switch "D" / "E" Voltage Correlation

DESCRIPTION

Refer to DTC P2122 (INF 104) (see page [HV-460](#)).

DTC No.	INF Code	DTC Detection Condition	Trouble Area
P2120	111	Accelerator pedal position main sensor value does not change while its sub sensor value changes	<ul style="list-style-type: none"> Accelerator pedal rod
P2121	106	Internal error of accelerator pedal position main sensor	<ul style="list-style-type: none"> Accelerator pedal rod
P2121	114	Accelerator pedal not smoothly returning to its original position	<ul style="list-style-type: none"> Accelerator pedal rod
P2125	112	Accelerator pedal position sub sensor value does not change while its main sensor value changes	<ul style="list-style-type: none"> Accelerator pedal rod
P2126	109	Internal error of accelerator pedal position sub sensor	<ul style="list-style-type: none"> Accelerator pedal rod
P2138	110	Difference between main sensor value and sub sensor value is large	<ul style="list-style-type: none"> Accelerator pedal rod

INSPECTION PROCEDURE

If any of the above information (INF) codes are present, replace the Accelerator pedal rod.

1	REPLACE ACCELERATOR PEDAL ROD
----------	--------------------------------------

(a) Replace the Accelerator pedal rod (see page [HV-567](#)).

NEXT

COMPLETED

DTC	P2122-104	Throttle / Pedal Position Sensor / Switch "D" Circuit Low Input
DTC	P2123-105	Throttle / Pedal Position Sensor / Switch "D" Circuit High Input
DTC	P2127-107	Throttle / Pedal Position Sensor / Switch "E" Circuit Low Input
DTC	P2128-108	Throttle / Pedal Position Sensor / Switch "E" Circuit High Input

DESCRIPTION

HINT:

- This is the repair procedure for the accelerator pedal position sensor.
- This electrical throttle system does not use a throttle cable.
- This accelerator pedal position sensor is a non-contact type.

The accelerator pedal position sensor is mounted on the accelerator pedal to detect how much it is depressed. It has 2 sensor terminals (VPA and VPA2) to detect the accelerator pedal position and a malfunction of the accelerator pedal position sensor itself. Since this sensor is electronically controlled with hall elements, accurate control and reliability can be obtained.

In the accelerator pedal position sensor, the voltage applied to terminals VPA and VPA2 of the HV control ECU changes between 0 V and 5 V in proportion to the degree of depressing the accelerator pedal. The VPA is a signal to indicate the actual accelerator pedal position angle which is used for the HV system control, and the VPA2 is a signal to indicate the actual accelerator pedal position angle which is used for detecting a malfunction of the sensor itself (terminal VPA).

The HV control ECU judges how much the accelerator pedal is being depressed from the VPA and VPA2 signals, and controls the HV system based on the signals.

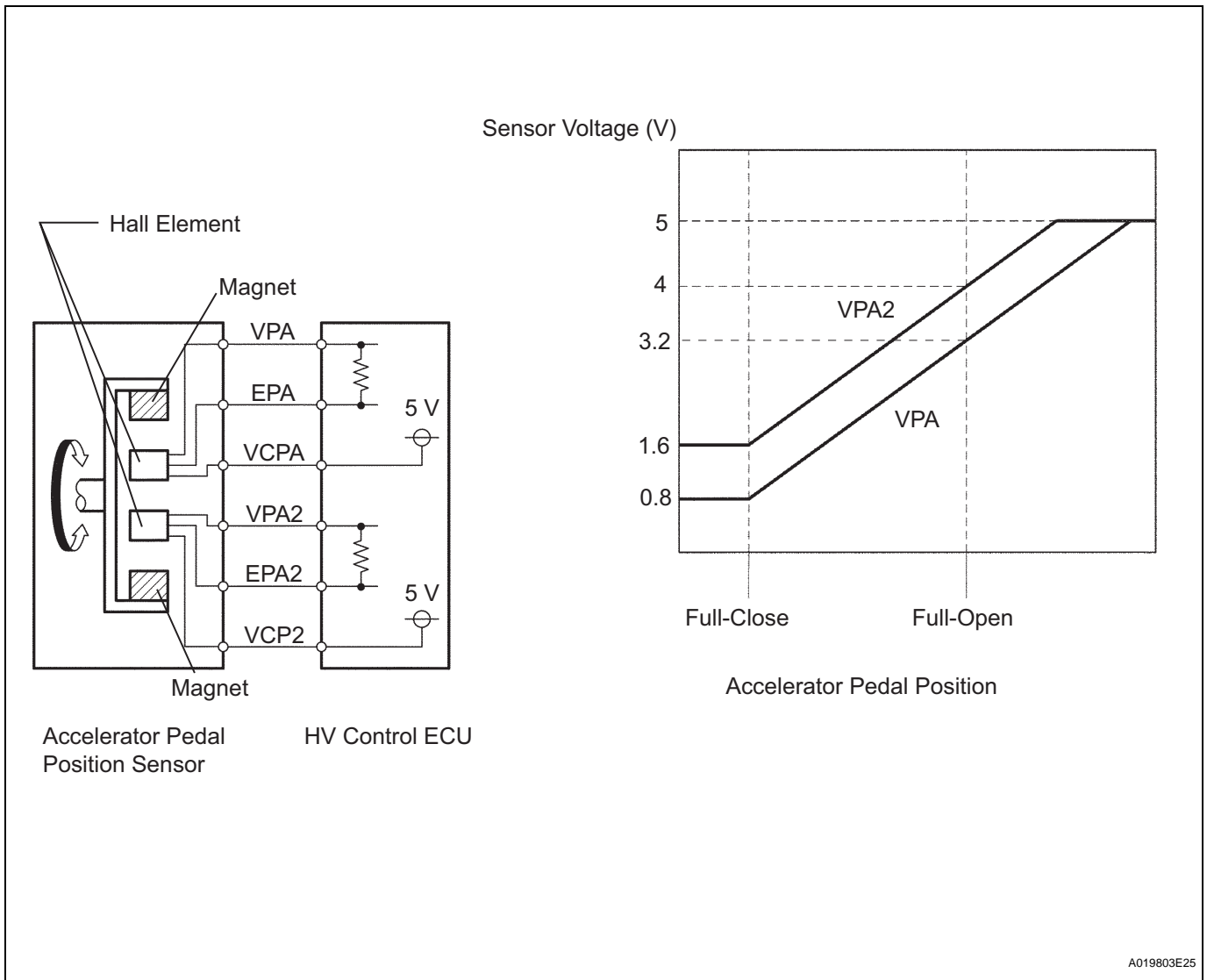

A019803E25

HV

DTC No.	INF Code	DTC Detection Condition	Trouble Area
P2122	104	Open or GND short in accelerator pedal position main sensor circuit	<ul style="list-style-type: none"> Wire harness or connector Accelerator pedal rod HV control ECU
P2123	105	+B short in accelerator pedal position main sensor circuit	<ul style="list-style-type: none"> Wire harness or connector Accelerator pedal rod HV control ECU
P2127	107	Open or GND short in accelerator pedal position sub sensor circuit	<ul style="list-style-type: none"> Wire harness or connector Accelerator pedal rod HV control ECU
P2128	108	+B short in accelerator pedal position sub sensor circuit	<ul style="list-style-type: none"> Wire harness or connector Accelerator pedal rod HV control ECU

WIRING DIAGRAM

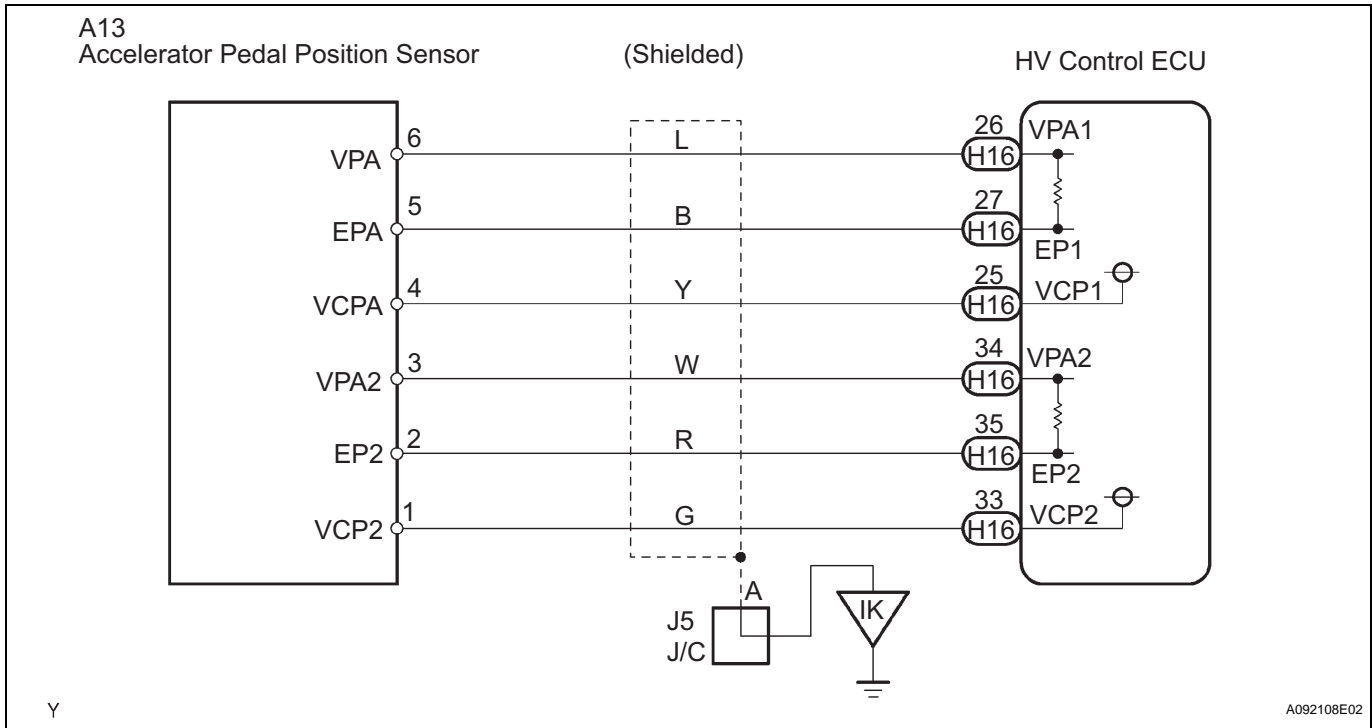

INSPECTION PROCEDURE

1 READ VALUE OF INTELLIGENT TESTER (ACCEL POS #1 AND #2)

HV

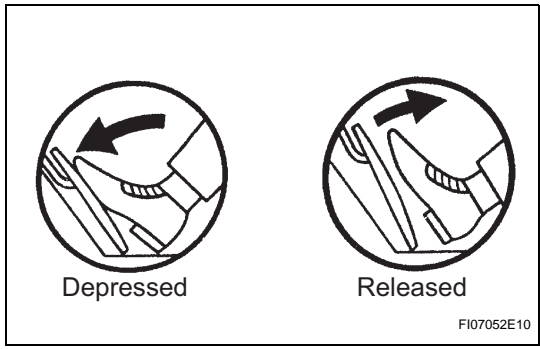

- (a) Connect the intelligent tester to the DLC3.
- (b) Turn the power switch ON (IG).
- (c) Turn the intelligent tester ON.
- (d) Enter the following menus: DIAGNOSIS / OBD/MOBD / HV ECU / DATA LIST.
- (e) Read the ACCEL POS #1 and #2 values on the intelligent tester with the engine stopped.

OK:
Changes with accelerator pedal pressure

NG

OK → **Go to step 5**

2

CHECK HARNESS AND CONNECTOR (HYBRID VEHICLE CONTROL ECU - ACCELERATOR PEDAL POSITION SENSOR)

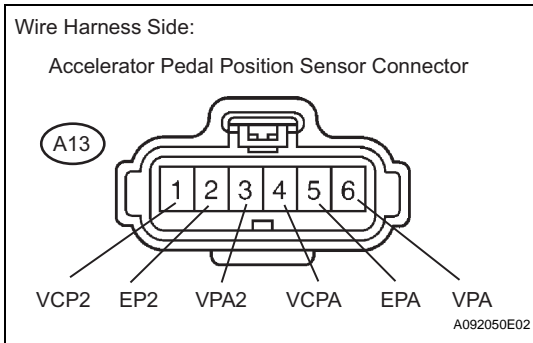
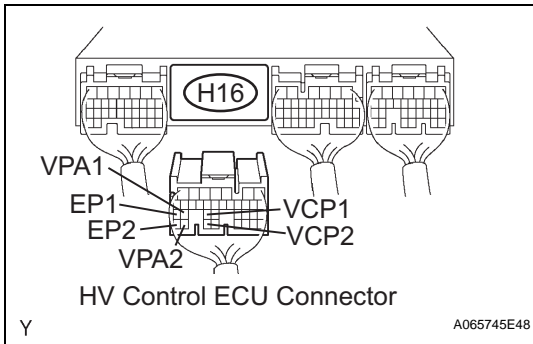

(a) Disconnect the H16 HV control ECU connector.

(b) Disconnect the A13 accelerator pedal position sensor connector.

(c) Turn the power switch ON (IG).

(d) Measure the voltage between the terminals of the HV control ECU connector and body ground.

Standard voltage

Tester Connection	Specified Condition
VPA1 (H16-26) - Body ground	Below 1 V
VCP1 (H16-25) - Body ground	Below 1 V
EP1 (H16-27) - Body ground	Below 1 V
VPA2 (H16-34) - Body ground	Below 1 V
VCP2 (H16-33) - Body ground	Below 1 V
EP2 (H16-35) - Body ground	Below 1 V

(e) Turn the power switch OFF.

(f) Measure the resistance between the wire harness side connectors.

Standard resistance (Check for open)

Tester Connection	Specified Condition
VPA1 (H16-26) - VPA (A13-6)	Below 1 Ω
VCP1 (H16-25) - VCPA (A13-4)	Below 1 Ω
EP1 (H16-27) - EPA (A13-5)	Below 1 Ω
VPA2 (H16-34) - VPA2 (A13-3)	Below 1 Ω
VCP2 (H16-33) - VCP2 (A13-1)	Below 1 Ω
EP2 (H16-35) - EP2 (A13-2)	Below 1 Ω

Standard resistance (Check for short)

Tester Connection	Specified Condition
VPA1 (H16-26) or VPA (A13-6) - Body ground	10 kΩ or higher
VCP1 (H16-25) or VCPA (A13-4) - Body ground	10 kΩ or higher
EP1 (H16-27) or EPA (A13-5) - Body ground	10 kΩ or higher
VPA2 (H16-34) or VPA2 (A13-3) - Body ground	10 kΩ or higher
VCP2 (H16-33) or VCP2 (A13-1) - Body ground	10 kΩ or higher

Tester Connection	Specified Condition
EP2 (H16-35) or EP2 (A13-2) - Body ground	10 kΩ or higher

- (g) Reconnect the accelerator pedal position sensor connector.
- (h) Reconnect the HV control ECU connector.

NG → **REPAIR OR REPLACE HARNESS OR CONNECTOR**

OK

3 INSPECT HYBRID VEHICLE CONTROL ECU (VCP1 OR VCP2 VOLTAGE)

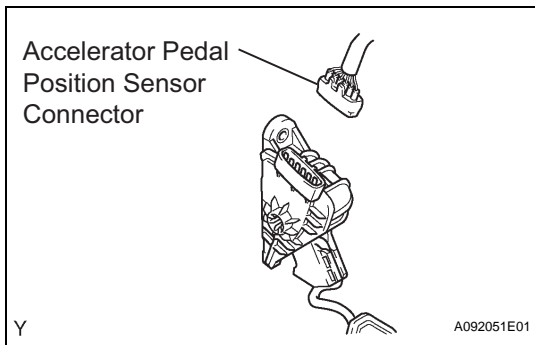

- (a) Disconnect the A13 accelerator pedal position sensor connector.
- (b) Turn the power switch ON (IG).

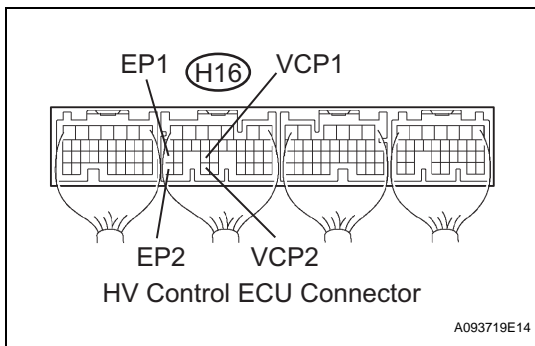

- (c) Measure the voltage between the terminals of the HV control ECU connector.
Standard voltage

Tester Connection	Specified Condition
VCP1 (H16-25) - EP1 (H16-27)	4.5 to 5.5 V
VCP2 (H16-33) - EP2 (H16-35)	4.5 to 5.5 V

- (d) Reconnect the accelerator pedal position sensor connector.

NG → **REPLACE HYBRID VEHICLE CONTROL ECU**

OK

4 REPLACE ACCELERATOR PEDAL ROD

- (a) Replace the Accelerator pedal rod (see page [HV-567](#)).

GO

5 CHECK IF DTC OUTPUT RECURS (DTC P2122, P2123, P2127 OR P2128)

- (a) Connect the intelligent tester to the DLC3.
- (b) Turn the power switch ON (IG).
- (c) Turn the intelligent tester ON.
- (d) Enter the following menus: DIAGNOSIS / OBD/MOBD / HV ECU / DTC INFO / CURRENT CODES.
- (e) Perform a simulation test.
- (f) Read DTCs.

HV

Result:
DTC P2122, P2123, P2127 or P2128 is not output
again

YES → SYSTEM IS OK

NO

REPLACE HYBRID VEHICLE CONTROL ECU

DTC	P3000-123	HV Battery Malfunction
DTC	P3000-125	HV Battery Malfunction
DTC	P3000-603	HV Battery Malfunction

DESCRIPTION

The HV control ECU gives warning to the driver and performs the fail-safe control, according to the abnormal signal received from the battery ECU.

DTC No.	INF Code	DTC Detection Condition	Trouble Area
P3000	123	Abnormal signal input from battery ECU (HV battery system malfunction)	<ul style="list-style-type: none"> • HV battery system • Battery ECU
P3000	125	Abnormal signal input from battery ECU (High voltage fuse blown out)	<ul style="list-style-type: none"> • HV battery system • Battery ECU
P3000	603	Abnormal signal input from battery ECU (HV battery cooling system malfunction)	<ul style="list-style-type: none"> • HV battery system • Battery ECU

INSPECTION PROCEDURE

HINT:

After repairing the malfunction, restart the system (to turn the READY light ON) and recheck the DTCs.

1	READ OUTPUT DTC (HV BATTERY)
----------	-------------------------------------

HV

- (a) Connect the intelligent tester to the DLC3.
- (b) Turn the power switch ON (IG).
- (c) Turn the intelligent tester ON.
- (d) Enter the following menus: DIAGNOSIS / OBD/MOBD / HV BATTERY / DTC INFO / TROUBLE CODES.
- (e) Read DTCs.

Result:

DTCs are output

YES	GO TO RELEVANT DTC CHART
------------	---------------------------------

NO

REPLACE BATTERY ECU ASSEMBLY

DTC	P3000-388	HV Battery Malfunction
------------	------------------	-------------------------------

DESCRIPTION

Based on the malfunction signal received from the battery ECU, the system alerts the driver and effects fail-safe control.
 This DTC is output when the SOC (state of charge) of the HV battery decreases as a result of leaving the vehicle in the N position, running out of fuel, or malfunction in the HV control system.

DTC No.	INF Code	DTC Detection Condition	Trouble Area
P3000	388	Abnormal signal input from battery ECU (discharge inhibition control malfunction)	<ul style="list-style-type: none"> HV control system Fuel shortage HV battery assembly

INSPECTION PROCEDURE

1	READ OUTPUT DTC (HV ECU)
----------	---------------------------------

- (a) Connect the intelligent tester to the DLC3.
- (b) Turn the power switch ON (IG).
- (c) Turn the intelligent tester ON.
- (d) Enter the following menus: DIAGNOSIS / OBD/MOBD / HV ECU / DTC INFO / CURRENT CODES.
- (e) Read DTCs.

Result:

DTC P3000 (INF 388) and other DTCs are output

HINT:

If any other codes besides P3000 (INF 388) are output, perform troubleshooting for those DTCs first.

YES	GO TO RELEVANT DTC CHART
------------	---------------------------------

HV

NO

2	CHECK AMOUNT OF GASOLINE
----------	---------------------------------

- (a) Turn the power switch ON (IG).
- (b) Check the amount of gasoline with the fuel gauge in the meter.

OK:

Appropriate amount of gasoline

NG	REFUEL GASOLINE
-----------	------------------------

OK

3	CHECK IF ENGINE STARTS
----------	-------------------------------

- (a) Turn the power switch ON (READY).
- (b) Check if the engine starts.

OK:

The engine starts

NO	REPLACE HV SUPPLY BATTERY ASSEMBLY
-----------	---

YES

LEAVE VEHICLE IN P POSITION, AND CHARGE HV BATTERY IN IDLE STATUS UNTIL IDLING STOPS

DTC	P3000-389	HV Battery Malfunction
------------	------------------	-------------------------------

DESCRIPTION

Based on the malfunction signal received from the battery ECU, the system alerts the driver and effects fail-safe control.

This DTC is output if the HV battery is depleted or the HV control system has malfunction.

DTC No.	INF Code	DTC Detection Condition	Trouble Area
P3000	389	Abnormal signal input from battery ECU (drop of high voltage)	<ul style="list-style-type: none"> HV control system HV battery assembly

INSPECTION PROCEDURE

1	READ OUTPUT DTC (HV ECU)
----------	---------------------------------

- (a) Connect the intelligent tester to the DLC3.
- (b) Turn the power switch ON (IG).
- (c) Turn the intelligent tester ON.
- (d) Enter the following menus: DIAGNOSIS / OBD/MOBD / HV ECU / DTC INFO / CURRENT CODES.
- (e) Read DTCs.

Result:

DTC P3000 (INF 389) and other DTCs are output

HINT:

If any other codes besides P3000 (INF 389) are output, perform troubleshooting for those DTCs first.

YES
GO TO RELEVANT DTC CHART

NO

HV

2	CHECK IF ENGINE STARTS
----------	-------------------------------

- (a) Turn the power switch ON (READY).
- (b) Check if the engine starts.

OK:

The engine starts

NG
REPLACE HV SUPPLY BATTERY ASSEMBLY

OK

LEAVE VEHICLE IN P POSITION, AND CHARGE HV BATTERY IN IDLE STATUS UNTIL IDLING STOPS

DTC	P3004-131	Power Cable Malfunction
------------	------------------	--------------------------------

DESCRIPTION

DTC No.	INF Code	DTC Detection Condition	Trouble Area
P3004	131	High voltage fuse has blown out, service plug grip is disconnected or limiter resistance is cut off	<ul style="list-style-type: none"> • HV battery system • System main resistor • No. 1 system main relay • No. 2 system main relay • No. 3 system main relay • Main battery cable • No. 2 main battery cable • Frame wire • Inverter with converter assembly • HV control ECU

WIRING DIAGRAM

Refer to DTC P0A78 (INF 266) (see page HV-223).

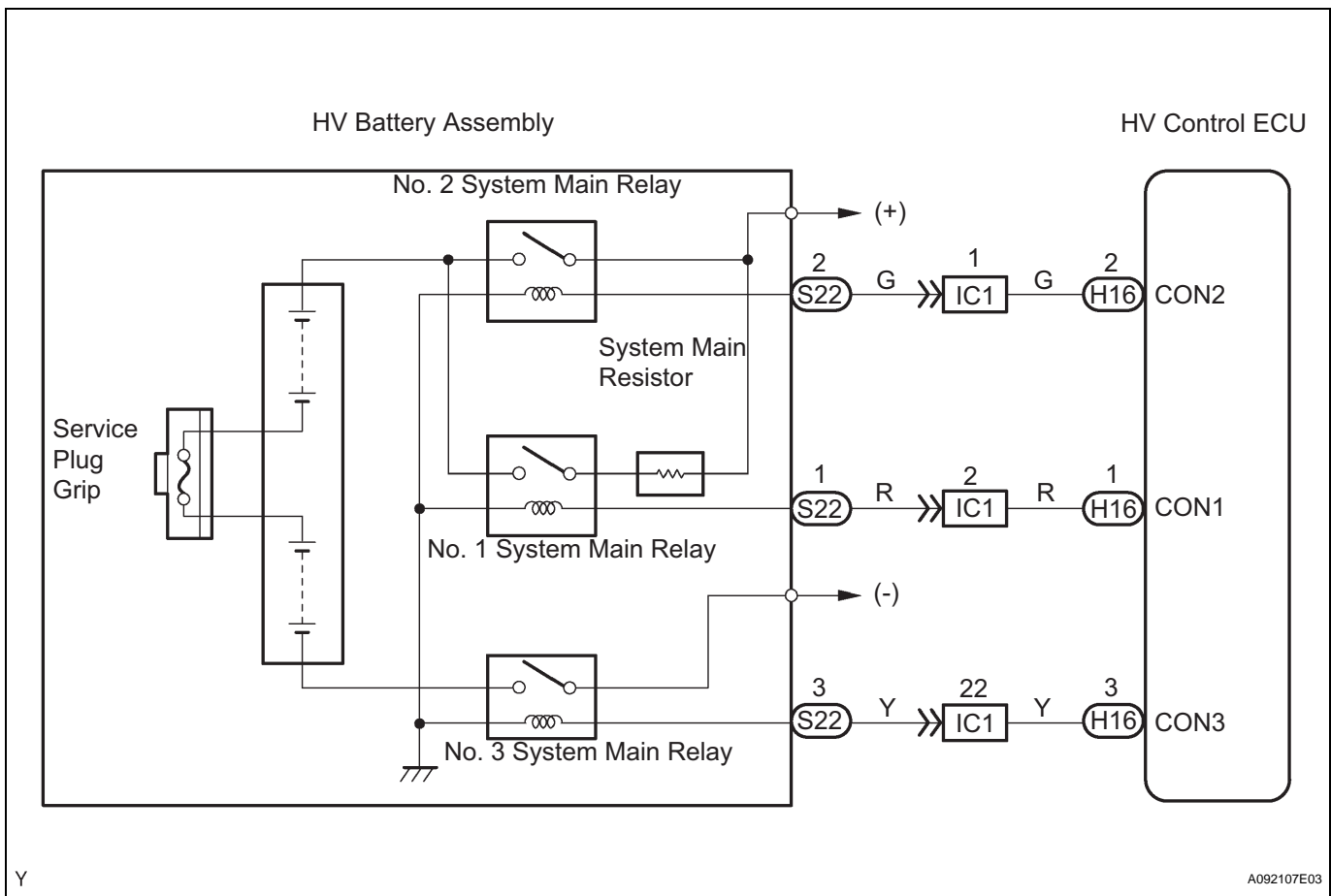

INSPECTION PROCEDURE

CAUTION:

- Before inspecting the high-voltage system, take safety precautions to prevent electrical shocks, such as wearing insulated gloves and removing the service plug grip. After removing the service plug grip, put it in your pocket to prevent other technicians from reconnecting it while you are servicing the high-voltage system.
- After disconnecting the service plug grip, wait for at least 5 minutes before touching any of the high-voltage connectors or terminals.

HINT:

At least 5 minutes are required to discharge the high-voltage condenser inside the inverter.

1 READ OUTPUT DTC (HV BATTERY)

- Connect the intelligent tester to the DLC3.
- Turn the power switch ON (IG).
- Turn the intelligent tester ON.
- Enter the following menus: DIAGNOSIS / OBD/MOBD / HV BATTERY / DTC INFO / TROUBLE CODES.
- Read DTCs.

Result:

DTC P0A95 is output

YES

GO TO DTC P0A95

NO

2 INSPECT SYSTEM MAIN RESISTOR

CAUTION:

Wear insulated gloves before performing the following operation.

- Remove the system main resistor (see page [HB-136](#)).
- Measure the resistance between the terminals.

Standard resistance:

18 to 22 Ω

- Reinstall the system main resistor (see page [HB-136](#)).

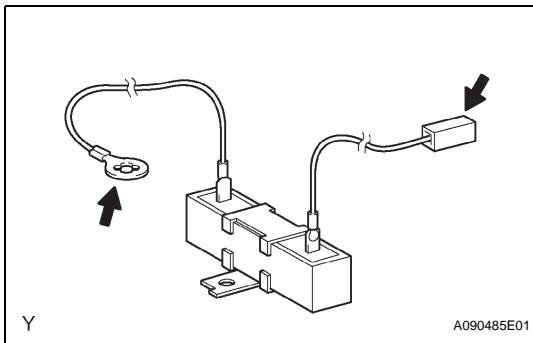

NG

REPLACE SYSTEM MAIN RESISTOR

OK

3 INSPECT NO. 1 SYSTEM MAIN RELAY

- Inspect the No. 1 system main relay (see page [HB-124](#)).

NG

REPLACE NO. 1 SYSTEM MAIN RELAY

OK

4 INSPECT NO. 2 SYSTEM MAIN RELAY

- Inspect the No. 2 system main relay (see page [HB-126](#)).

NG

REPLACE NO. 2 SYSTEM MAIN RELAY

OK

HV

5 INSPECT NO. 3 SYSTEM MAIN RELAY

(a) Inspect the No. 3 system main relay (see page [HB-126](#)).

NG

REPLACE NO. 3 SYSTEM MAIN RELAY

OK

6 INSPECT MAIN BATTERY CABLE**CAUTION:**

Wear insulated gloves and goggles before performing the following operation.

- Remove the HV battery assembly (see page [HB-92](#)).
- Remove the main battery cable (see page [HB-103](#)).
- Measure the resistance between the terminals of the main battery cable.

Standard resistance:

Below 1 Ω

NG

REPLACE MAIN BATTERY CABLE

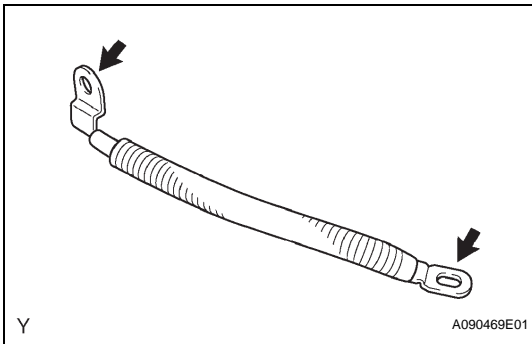

OK

7 INSPECT MAIN BATTERY CABLE**CAUTION:**

Wear insulated gloves and goggles before performing the following operation.

- Check the cover and terminals of the main battery cable for any abnormality.

OK:

No abnormality is found on the cover and terminals.

- Check the terminals of the HV battery and the system main relay, which are to be connected to the main cable, for any abnormality.

OK:

No abnormality is found on the terminals of the HV battery and system main relay.

NG

REPLACE MAIN BATTERY CABLE. IF NECESSARY, REPLACE HV BATTERY OR SYSTEM MAIN RELAY

OK

HV

8 INSPECT NO. 2 MAIN BATTERY CABLE**CAUTION:**

Wear insulated gloves and goggles before performing the following operation.

- (a) Remove the No. 2 main battery cable with the HV battery assembly removed (see page [HB-103](#)).
- (b) Measure the resistance between the terminals of the No. 2 main battery cable.

Standard resistance:

Below 1 Ω

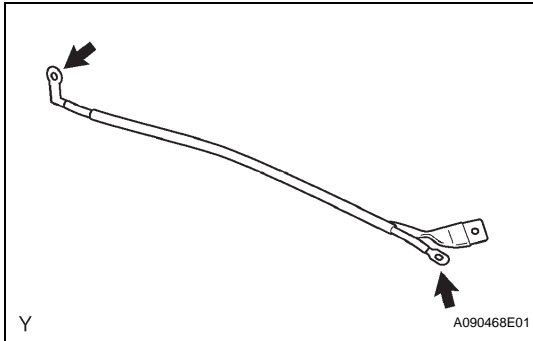

NG

REPLACE NO. 2 MAIN BATTERY CABLE

OK

9 INSPECT NO. 2 MAIN BATTERY CABLE**CAUTION:**

Wear insulated gloves and goggles before performing the following operation.

- (a) Check the cover and terminals of the No. 2 main battery cable for any abnormality.

OK:

No abnormality is found on the cover and terminals.

- (b) Check the terminals of the HV battery and the system main relay, which are to be connected to the No. 2 main battery cable, for any abnormality.

OK:

No abnormality is found on the terminals of the HV battery and system main relay.

NG

REPLACE NO. 2 MAIN BATTERY CABLE. IF NECESSARY, REPLACE HV BATTERY OR SYSTEM MAIN RELAY

OK

10 INSPECT FRAME WIRE**CAUTION:**

Wear insulated gloves before performing the following operation.

HV

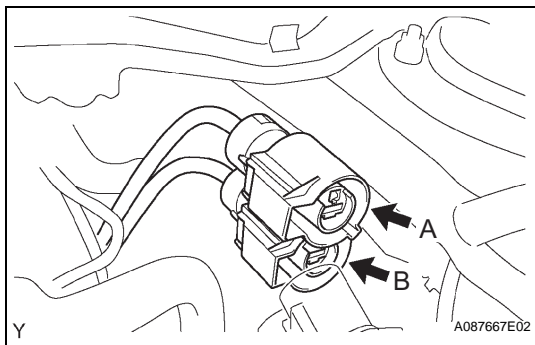

- (a) Disconnect the frame wire from the inverter with converter.

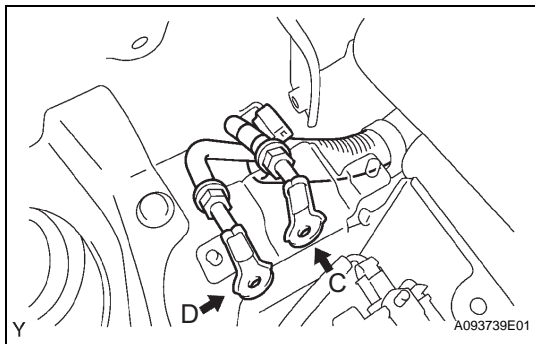

- (b) Check that the frame wire has been disconnected from the system main relay.
- (c) Using a megohmmeter, measure the insulation resistance between the high-voltage terminals of the frame wire and body ground.

Standard resistance

Tester Connection	Specified Condition
A - Body ground	10 MΩ or higher
B - Body ground	10 MΩ or higher

- (d) Measure the resistance between the terminals of the frame wire.

Standard resistance

Tester Connection	Specified Condition
A - C	Below 1 Ω
B - D	Below 1 Ω

- (e) Reinstall the HV battery assembly (see page [HB-96](#)).
- (f) Reconnect the frame wire.

NG → **REPLACE FRAME WIRE**

OK

11 CHECK HARNESS AND CONNECTOR (HYBRID VEHICLE CONTROL ECU - INVERTER)

CAUTION:

Wear insulated gloves before performing the following operation.

- (a) Turn the power switch OFF.
- (b) Remove the service plug grip (see page [HB-154](#)).

NOTICE:

Turning the power switch ON (READY) with the service plug grip removed could cause malfunction. Therefore, never turn the power switch ON (READY) in this state.

- (c) Remove the inverter cover (see page [HV-531](#)).

HV

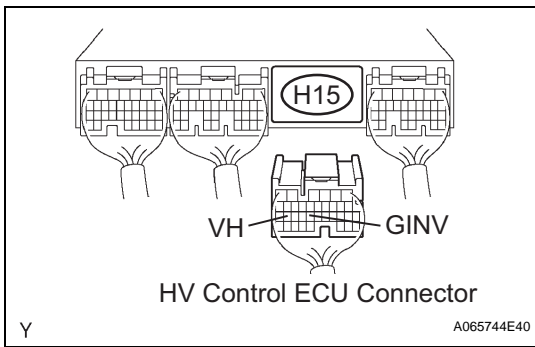

(d) Disconnect the H15 HV control ECU connector.

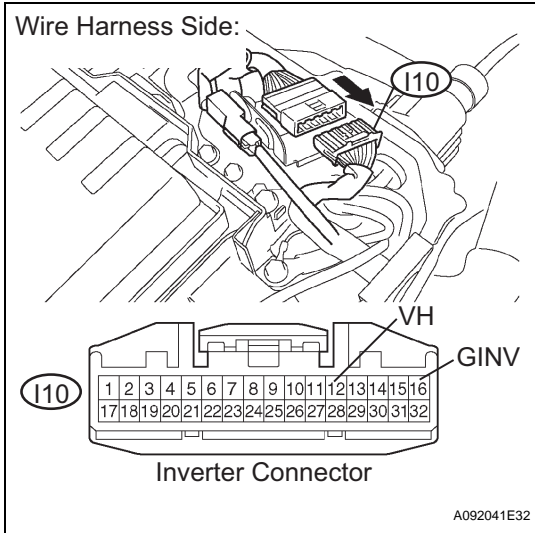

(e) Disconnect the I10 inverter connector.
Standard resistance (Check for open)

Tester Connection	Specified Condition
VH (H15-26) - VH (I10-12)	Below 1 Ω
GINV (H15-23) - GINV (I10-16)	Below 1 Ω

(f) Turn the power switch OFF.
(g) Measure the resistance between the wire harness side connectors.

Standard resistance (Check for short)

Tester Connection	Specified Condition
VH (H15-26) or VH (I10-12) - Body ground	10 MΩ or higher
GINV (H15-23) or GINV (I10-16) - Body ground	10 MΩ or higher

- (h) Reconnect the inverter connector.
- (i) Reconnect the HV control ECU connector.
- (j) Reinstall the inverter cover (see page HV-538).
- (k) Reinstall the service plug grip (see page HB-154).

NG REPAIR OR REPLACE HARNESS OR CONNECTOR

OK

12 INSPECT HYBRID VEHICLE CONTROL ECU (HV VOLTAGE)

- (a) Turn the power switch ON (READY).
HINT:
DTCs for the interlock switch system are output when turning the power switch ON (IG) with both service plug grip and inverter cover removed.

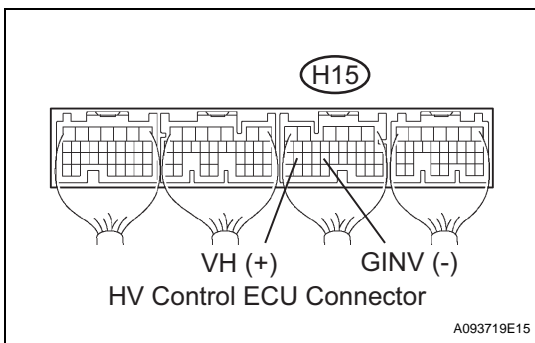

(b) Measure the voltage between the terminals of the H15 HV control ECU connector.

Standard voltage

Tester Connection	Specified Condition
VH (H15-26) - GINV (H15-23)	0.3 to 0.7 V

NG REPLACE INVERTER WITH CONVERTER ASSEMBLY

HV

OK

REPLACE HYBRID VEHICLE CONTROL ECU

DTC	P3004-132	Power Cable Malfunction
------------	------------------	--------------------------------

DESCRIPTION

DTC No.	INF Code	DTC Detection Condition	Trouble Area
P3004	132	Inverter voltage sensor malfunction, or limiter resistance increases	<ul style="list-style-type: none"> • HV control system • System main resistor • No. 1 system main relay • No. 3 system main relay • Main battery cable • No. 2 main battery cable • Frame wire • Inverter with converter assembly • HV control ECU

WIRING DIAGRAM

Refer to DTC P3004 (INF 131) (see page [HV-470](#)).

INSPECTION PROCEDURE

CAUTION:

- Before inspecting the high-voltage system, take safety precautions to prevent electrical shocks, such as wearing insulated gloves and removing the service plug grip. After removing the service plug grip, put it in your pocket to prevent other technicians from reconnecting it while you are servicing the high-voltage system.
- After disconnecting the service plug grip, wait for at least 5 minutes before touching any of the high-voltage connectors or terminals.

HINT:

At least 5 minutes are required to discharge the high-voltage condenser inside the inverter.

1	READ OUTPUT DTC (HV ECU)
----------	---------------------------------

HV

- (a) Connect the intelligent tester to the DLC3.
- (b) Turn the power switch ON (IG).
- (c) Turn the intelligent tester ON.
- (d) Enter the following menus: DIAGNOSIS / OBD/MOBD / HV ECU / DTC INFO / CURRENT CODES.
- (e) Read DTCs.

Result:

DTC P3004 (INF 132) and other DTCs are output

HINT:

If any other codes besides P3004 (INF 132) are output, perform troubleshooting for those DTCs first.

YES	GO TO RELEVANT DTC CHART
------------	---------------------------------

NO

2	INSPECT SYSTEM MAIN RESISTOR
----------	-------------------------------------

CAUTION:

Wear insulated gloves and goggles before performing the following operation.

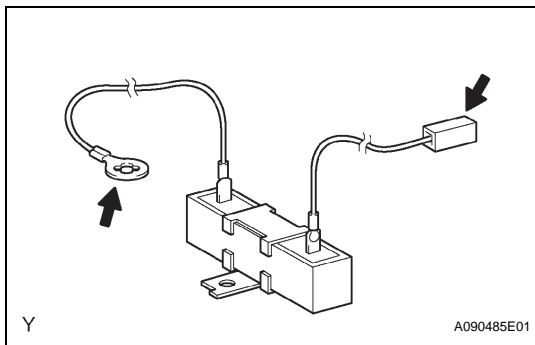

- (a) Remove the system main resistor (see page [HB-136](#)).
- (b) Measure the resistance between the terminals.
Standard resistance:
18 to 22 Ω
- (c) Reinstall the system main resistor (see page [HB-136](#)).

NG

REPLACE SYSTEM MAIN RESISTOR

OK

3 INSPECT NO. 1 SYSTEM MAIN RELAY

- (a) Inspect the No. 1 system main relay (see page [HB-124](#)).

NG

REPLACE NO. 1 SYSTEM MAIN RELAY

OK

4 INSPECT NO. 3 SYSTEM MAIN RELAY

- (a) Inspect the No. 3 system main relay (see page [HB-126](#)).

NG

REPLACE NO. 3 SYSTEM MAIN RELAY

OK

5 INSPECT MAIN BATTERY CABLE

CAUTION:

Wear insulated gloves and goggles before performing the following operation.

- (a) Remove the HV battery assembly (see page [HB-92](#)).
- (b) Remove the main battery cable (see page [HB-103](#)).
- (c) Measure the resistance between the terminals of the main battery cable.

Standard resistance:**Below 1 Ω**

NG

REPLACE MAIN BATTERY CABLE

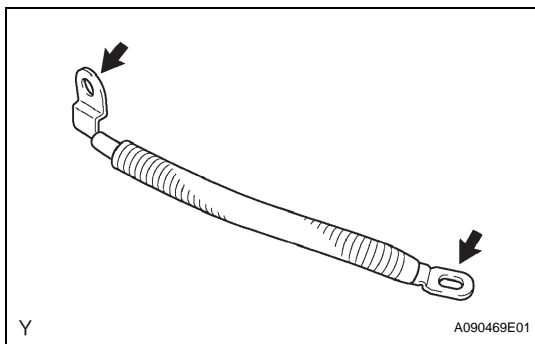

OK

6 INSPECT MAIN BATTERY CABLE

CAUTION:

Wear insulated gloves and goggles before performing the following operation.

- (a) Check the cover and terminals of the main battery cable for any abnormality.

OK:

No abnormality is found on the cover and terminals.

- (b) Check the terminals of the HV battery and the system main relay, which are to be connected to the main cable, for any abnormality.

OK:

No abnormality is found on the terminals of the HV battery and system main relay.

NG

REPLACE MAIN BATTERY CABLE. IF NECESSARY, REPLACE HV BATTERY OR SYSTEM MAIN RELAY

OK

7 INSPECT NO. 2 MAIN BATTERY CABLE

CAUTION:

Wear insulated gloves and goggles before performing the following operation.

- (a) Remove the No. 2 main battery cable with the HV battery assembly removed (see page [HB-103](#)).
- (b) Measure the resistance between the terminals of the No. 2 main battery cable.

Standard resistance:

Below 1 Ω

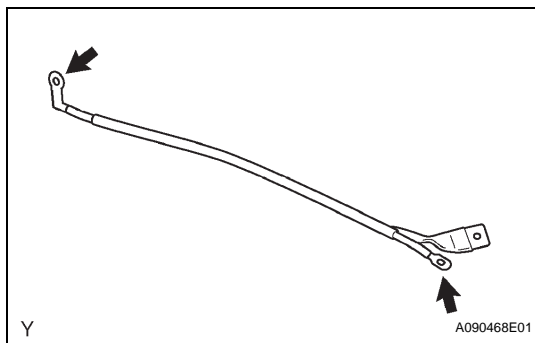

NG

REPLACE NO. 2 MAIN BATTERY CABLE

HV

OK

8 INSPECT NO. 2 MAIN BATTERY CABLE

CAUTION:

Wear insulated gloves and goggles before performing the following operation.

- (a) Check the cover and terminals of the No. 2 main battery cable for any abnormality.

OK:

No abnormality is found on the cover and terminals.

- (b) Check the terminals of the HV battery and the system main relay, which are to be connected to the No. 2 main battery cable, for any abnormality.

OK:

No abnormality is found on the terminals of the HV battery and system main relay.

NG

REPLACE NO. 2 MAIN BATTERY CABLE. IF NECESSARY, REPLACE HV BATTERY OR SYSTEM MAIN RELAY

OK

9 INSPECT FRAME WIRE

CAUTION:
Wear insulated gloves before performing the following operation.

(a) Disconnect the frame wire from the inverter with converter.

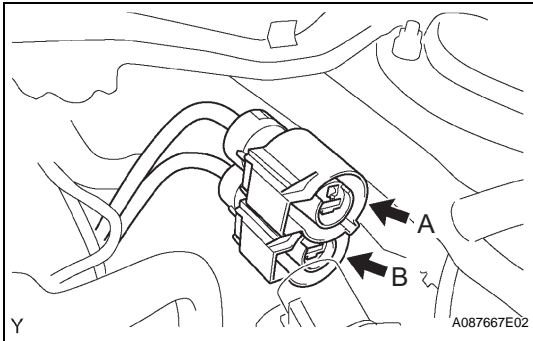

(b) Check that the frame wire has been disconnected from the system main relay.

(c) Using a megohmmeter, measure the insulation resistance between the high-voltage terminals of the frame wire and body ground.

Standard resistance

Tester Connection	Specified Condition
A - Body ground	10 MΩ or higher
B - Body ground	10 MΩ or higher

(d) Measure the resistance between the terminals of the frame wire.

Standard resistance

Tester Connection	Specified Condition
A - C	Below 1 Ω
B - D	Below 1 Ω

(e) Reinstall the HV battery assembly (see page [HB-96](#)).

(f) Reconnect the frame wire.

NG

REPLACE FRAME WIRE

OK

10 CHECK HARNESS AND CONNECTOR (HYBRID VEHICLE CONTROL ECU - INVERTER)

CAUTION:
Wear insulated gloves before performing the following operation.

(a) Turn the power switch OFF.

(b) Remove the service plug grip (see page [HB-154](#)).

HV

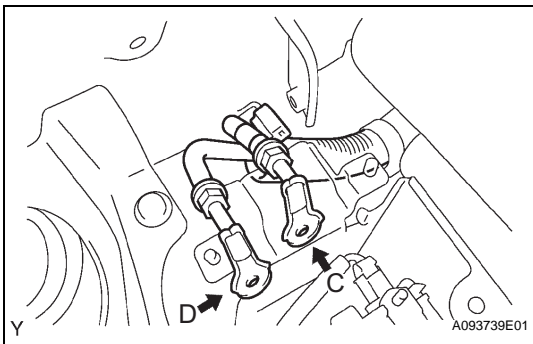

NOTICE:

Turning the power switch ON (READY) with the service plug grip removed could cause malfunction. Therefore, never turn the power switch ON (READY) in this state.

- (c) Remove the inverter cover (see page HV-531).
- (d) Disconnect the H15 HV control ECU connector.

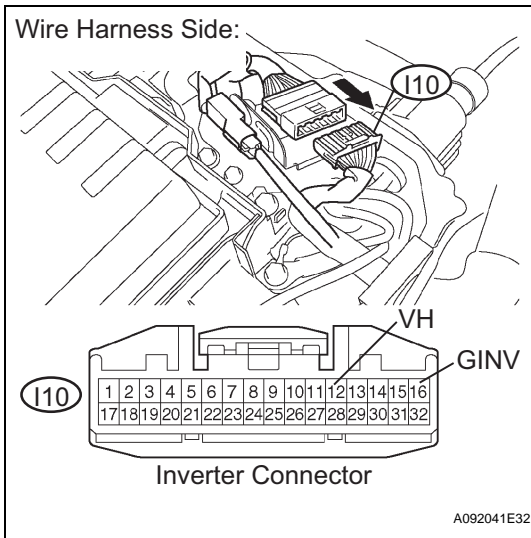
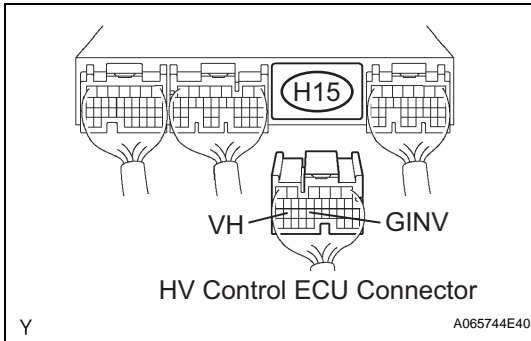

- (e) Disconnect the I10 inverter connector.
- (f) Turn the power switch ON (IG).
HINT:
DTCs for the interlock switch system are output when turning the power switch ON (IG) with both service plug grip and inverter cover removed.
- (g) Measure the voltage between the terminals of the HV control ECU connector and body ground.
Standard voltage (Check for open)

Tester Connection	Specified Condition
VH (H15-26) - Body ground	Below 1 V
GINV (H15-23) - Body ground	Below 1 V

- (h) Turn the power switch OFF.
- (i) Measure the resistance between the wire harness side connectors.

Standard resistance (Check for short)

Tester Connection	Specified Condition
VH (H15-26) or VH (I10-12) - Body ground	10 kΩ or higher
GINV (H15-23) or GINV (I10-16) - Body ground	10 kΩ or higher

- (j) Reconnect the inverter connector.
- (k) Reconnect the HV control ECU connector.
- (l) Reinstall the inverter cover (see page HV-538).
- (m) Reinstall the service plug grip (see page HB-154).

NG → **REPAIR OR REPLACE HARNESS OR CONNECTOR**

OK

11 CHECK HYBRID VEHICLE CONTROL ECU (VH VOLTAGE)

- (a) Turn the power switch ON (READY).

HV

HINT:

DTCs for the interlock switch system are output when turning the power switch ON (IG) with both service plug grip and inverter cover removed.

- (b) Measure the voltage between the terminals of the H15 HV control ECU connector.

Standard voltage

Tester Connection	Specified Condition
VH (H15-26) - GINV (H15-23)	1.6 to 3.8 V

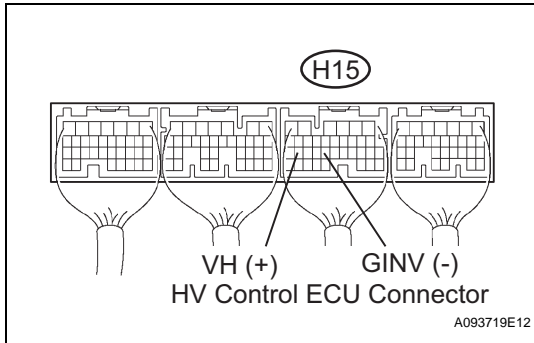

NG

REPLACE INVERTER WITH CONVERTER ASSEMBLY

OK

REPLACE HYBRID VEHICLE CONTROL ECU

DTC**P3004-133****Power Cable Malfunction****DESCRIPTION**

The HV control ECU gives warning to the driver and performs the fail-safe control, according to the abnormal signal received from the battery ECU.

DTC No.	INF Code	DTC Detection Condition	Trouble Area
P3004	133	Abnormal signal input from battery ECU	<ul style="list-style-type: none"> • HV battery system • Battery ECU

INSPECTION PROCEDURE**1****READ OUTPUT DTC (HV BATTERY)**

- (a) Connect the intelligent tester to the DLC3.
- (b) Turn the power switch ON (IG).
- (c) Turn the intelligent tester ON.
- (d) Enter the following menus: DIAGNOSIS / OBD/MOBD / HV BATTERY / DTC INFO / TROUBLE CODES.
- (e) Read DTCs.

Result:**DTCs are output****YES****GO TO RELEVANT DTC CHART****NO****REPLACE BATTERY ECU ASSEMBLY****HV**

DTC	P3102-524	Transmission Control ECU Malfunction
DTC	P3102-525	Transmission Control ECU Malfunction
DTC	P3102-581	Transmission Control ECU Malfunction
DTC	P3102-582	Transmission Control ECU Malfunction
DTC	P3102-597	Transmission Control ECU Malfunction
DTC	P3102-598	Transmission Control ECU Malfunction
DTC	P3102-599	Transmission Control ECU Malfunction

DESCRIPTION

When a signal is input from the P position switch or selector lever, the HV control ECU transmits a P position control (PCON) signal to the transmission control ECU assembly. Based on this signal, the transmission control ECU assembly actuates the shift control actuator in order to mechanically lock or unlock the counter drive gear in the HV transaxle assembly. If the shift control actuator is in the P position, the transmission control ECU assembly transmits a P position (PPOS) signal to the HV control ECU.

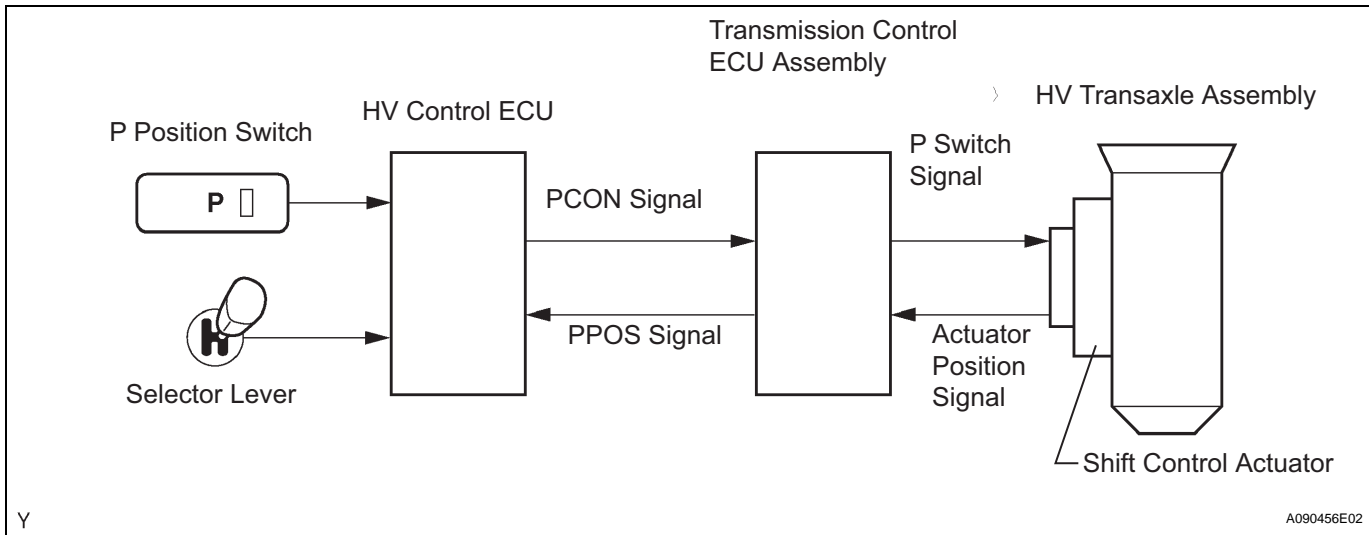

DTC No.	INF Code	DTC Detection Condition	Trouble Area
P3102	524	BEAN communication problem of transmission control ECU assembly	<ul style="list-style-type: none"> • Wire harness or connector • Transmission control ECU assembly • HV control ECU • Power source control ECU
P3102	525	Transmission control ECU IG OFF command malfunction	<ul style="list-style-type: none"> • Wire harness or connector • Transmission control ECU assembly • HV control ECU • Power source control ECU
P3102	581	Transmission control ECU malfunction	<ul style="list-style-type: none"> • Wire harness or connector • Transmission control ECU assembly • HV control ECU • Power source control ECU

DTC No.	INF Code	DTC Detection Condition	Trouble Area
P3102	582	P position (PPOS) signal is logically inconsistent	<ul style="list-style-type: none"> Wire harness or connector Transmission control ECU assembly HV control ECU Power source control ECU
P3102	597	GND short in P position (PPOS) signal circuit	<ul style="list-style-type: none"> Wire harness or connector Transmission control ECU assembly HV control ECU Power source control ECU
P3102	598	+B short in P position (PPOS) signal circuit	<ul style="list-style-type: none"> Wire harness or connector Transmission control ECU assembly HV control ECU Power source control ECU
P3102	599	P position (PPOS) signal malfunction (output pulse is abnormal)	<ul style="list-style-type: none"> Wire harness or connector Transmission control ECU assembly HV control ECU Power source control ECU

WIRING DIAGRAM

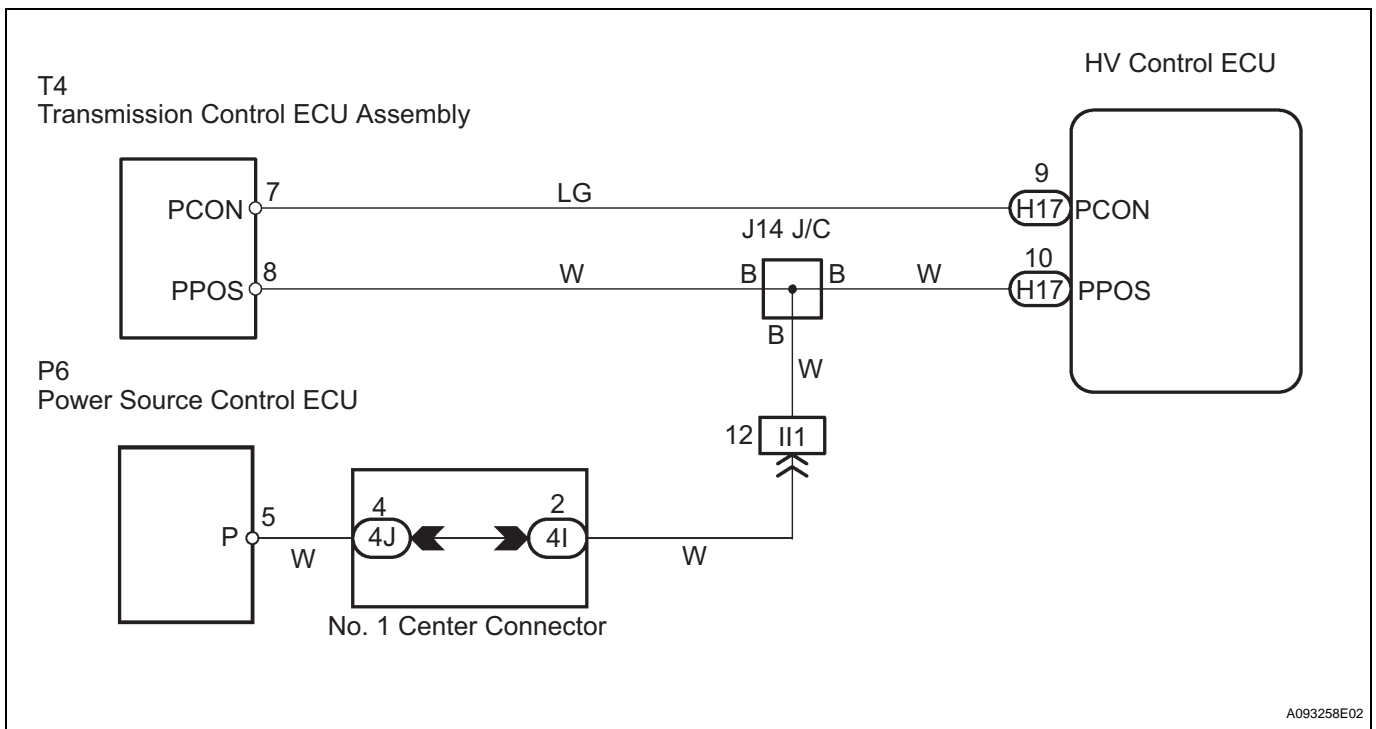

HV

INSPECTION PROCEDURE

1 CHECK HARNESS AND CONNECTOR (HYBRID VEHICLE CONTROL ECU - TRANSMISSION CONTROL ECU ASSEMBLY AND POWER SOURCE CONTROL ECU)

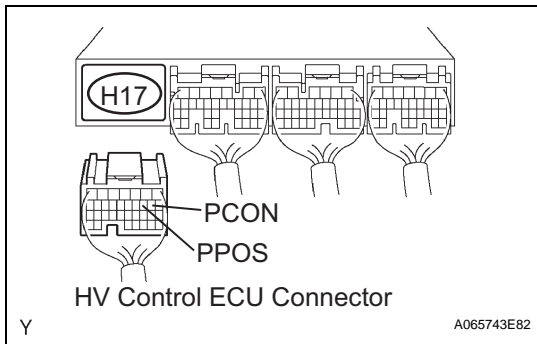

(a) Disconnect the H17 HV control ECU connector.

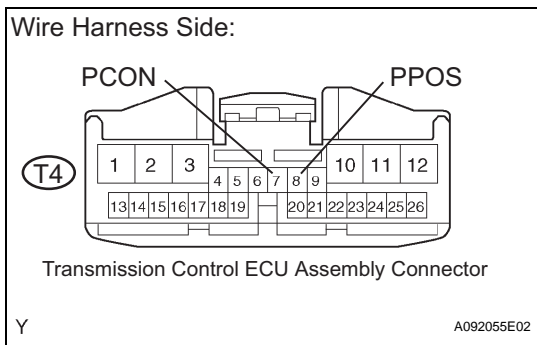

(b) Disconnect the T4 transmission control ECU assembly connector.

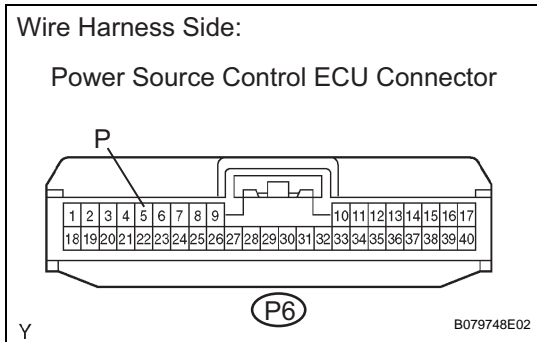

(c) Disconnect the P6 power source control ECU connector.
 (d) Measure the voltage between the terminals of the HV control ECU connector and body ground.

Standard voltage

Tester Connection	Specified Condition
PCON (H17-9) - Body ground	Below 1 V
PPOS (H17-10) - Body ground	Below 1 V

(e) Measure the resistance between the wire harness side connectors.

Standard resistance (Check for open)

Tester Connection	Specified Condition
PCON (H17-9) - PCON (T4-7)	Below 1 Ω
PPOS (H17-10) - PPOS (T4-8)	Below 1 Ω
PPOS (H17-10) - P (P6-5)	Below 1 Ω

Standard resistance (Check for short)

Tester Connection	Specified Condition
PCON (H17-9) or PCON (T4-7) - Body ground	10 kΩ or higher
PPOS (H17-10) or PPOS (T4-8) - Body ground	10 kΩ or higher
PPOS (H17-10) or P (P6-5) - Body ground	10 kΩ or higher

(f) Reconnect the power source control ECU connector.
 (g) Reconnect the transmission control ECU assembly connector.

HV

(h) Reconnect the HV control ECU connector.

NG **REPAIR OR REPLACE HARNESS OR CONNECTOR**

OK

2 CHECK HARNESS AND CONNECTOR (CHECK FOR +B SHORT IN WIRE HARNESS)

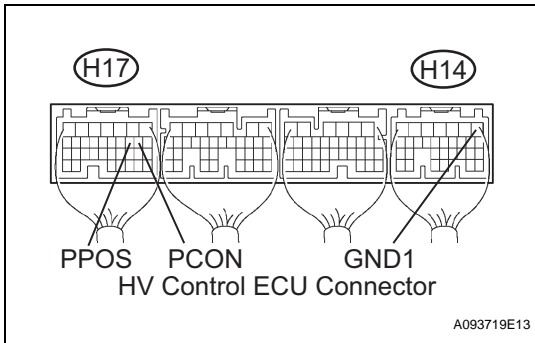

- (a) Inspect the HV control ECU using an oscilloscope.
- (b) Turn the power switch ON (IG).

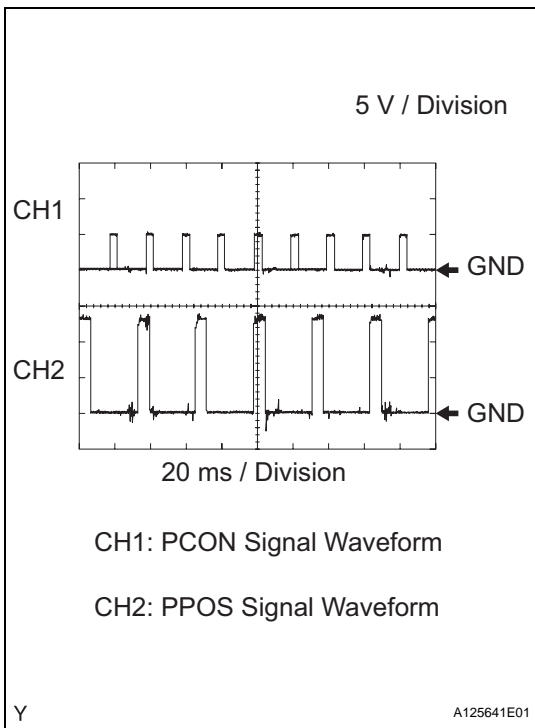

- (c) Check the waveforms of the voltages between the terminals PCON (H17-9) and GND1 (H14-1), and terminals PPOS (H17-10) and GND1 (H14-1), of the HV control ECU connectors, in order to check for +B short in the signal lines PCON and PPOS.

OK:

No +B short in either PCON or PPOS signal lines.

HINT:

- If there is +B short in the signal line, the output voltage is constantly between 9 V and 14 V.
- If the signal lines are normal, the waveforms are displayed as shown in the diagram.

NG **REPAIR OR REPLACE HARNESS OR CONNECTOR**

OK

3 READ OUTPUT DTC (T/M CONTROL)

- (a) Connect the intelligent tester to the DLC3.
- (b) Turn the power switch ON (IG).
- (c) Turn the intelligent tester ON.
- (d) Enter the following menus: DIAGNOSIS / OBD/MOBD / T/M CONTROL / DTC INFO / TROUBLE CODES.
- (e) Read DTCs.

Result:

DTCs are output

HV

YES

GO TO RELEVANT DTC CHART

NO

REPLACE HV CONTROL ECU, TRANSMISSION ECU AND POWER SOURCE CONTROL ECU

DTC	P3107-213	Airbag ECU Communication Circuit Malfunction
DTC	P3107-214	Airbag ECU Communication Circuit Malfunction
DTC	P3107-215	Airbag ECU Communication Circuit Malfunction

DESCRIPTION

The HV control ECU detects a malfunction of the collision signal circuit from the center airbag sensor and gives warning to the driver.

DTC No.	INF Code	DTC Detection Condition	Trouble Area
P3107	213	GND short in communication circuit between center airbag sensor and HV control ECU	<ul style="list-style-type: none"> • Wire harness or connector • Center airbag sensor
P3107	214	Open or +B short in communication circuit between center airbag sensor and HV control ECU	<ul style="list-style-type: none"> • Wire harness or connector • Center airbag sensor
P3107	215	Abnormal communication signals between center airbag sensor and HV control ECU	<ul style="list-style-type: none"> • Wire harness or connector • Center airbag sensor

WIRING DIAGRAM

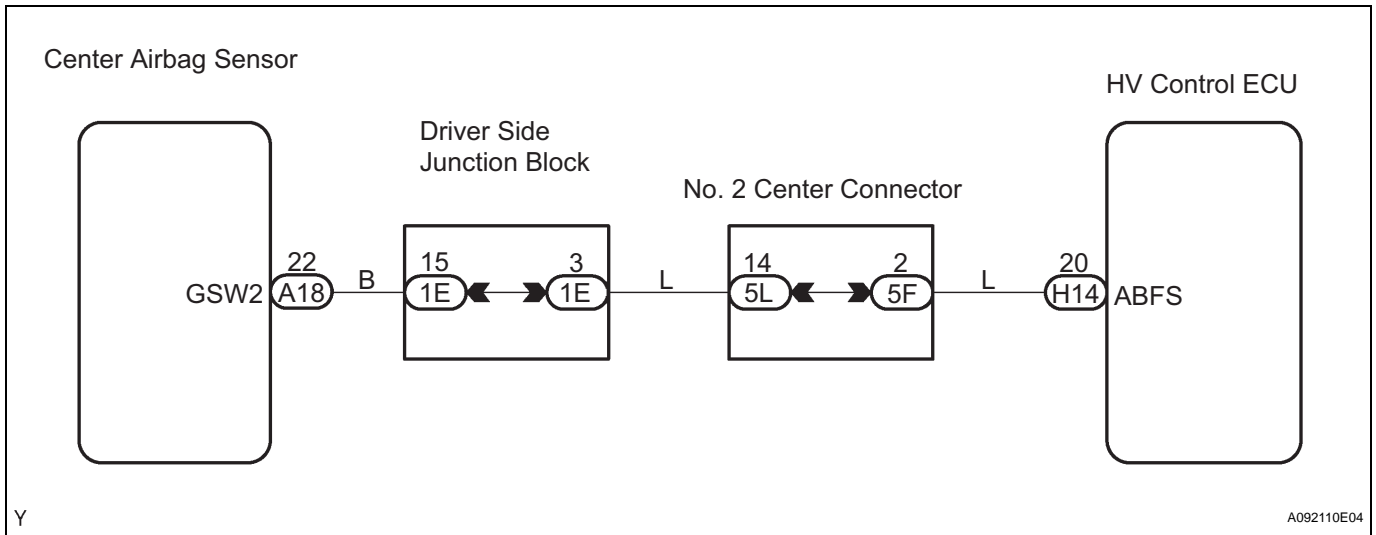

HV

INSPECTION PROCEDURE

1 CHECK HARNESS AND CONNECTOR (HYBRID VEHICLE CONTROL ECU - CENTER AIRBAG SENSOR)

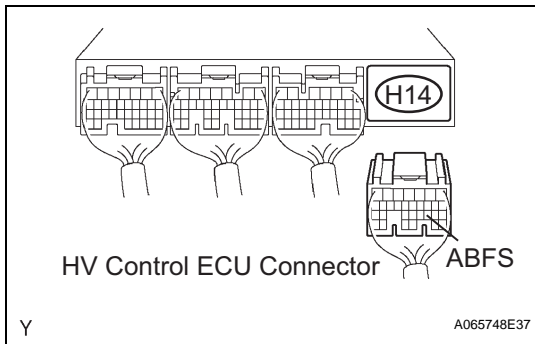

(a) Disconnect the H14 HV control ECU connector.

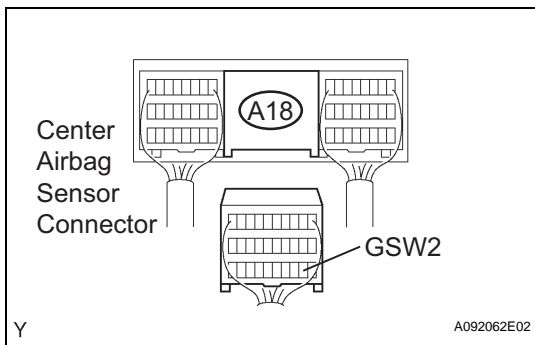

- (b) Disconnect the A18 center airbag sensor connector.
- (c) Turn the power switch ON (IG).
- (d) Measure the voltage between the terminal of the HV control ECU connector and body ground.

Standard voltage

Tester Connection	Specified Condition
ABFS (H14-20) - Body ground	Below 1 V

- (e) Turn the power switch OFF.
- (f) Measure the resistance between the wire harness side connectors.

Standard resistance (Check for open)

Tester Connection	Specified Condition
ABFS (H14-20) - GSW2 (A18-22)	Below 1 Ω

Standard resistance (Check for short)

Tester Connection	Specified Condition
ABFS (H14-20) or GSW2 (A18-22) - Body ground	10 kΩ higher

- (g) Reconnect the center airbag sensor connector.
- (h) Reconnect the HV control ECU connector.

NG **REPAIR OR REPLACE HARNESS OR CONNECTOR**

OK

REPLACE CENTER AIRBAG SENSOR

HV

DTC	P3108-535	A/C Amplifier Communication Circuit Malfunction
DTC	P3108-536	A/C Amplifier Communication Circuit Malfunction
DTC	P3108-538	A/C Amplifier Communication Circuit Malfunction

DESCRIPTION

The HV control ECU detects a wiring malfunction in the serial communication line of the A/C inverter.

DTC No.	INF Code	DTC Detection Condition	Trouble Area
P3108	535	Serial communication malfunction	<ul style="list-style-type: none"> • Wire harness or connector • Inverter with converter assembly
P3108	536	A/C inverter malfunction	<ul style="list-style-type: none"> • Wire harness or connector • Inverter with converter assembly
P3108	538	Open in STB signal circuit	<ul style="list-style-type: none"> • Wire harness or connector • Inverter with converter assembly

WIRING DIAGRAM

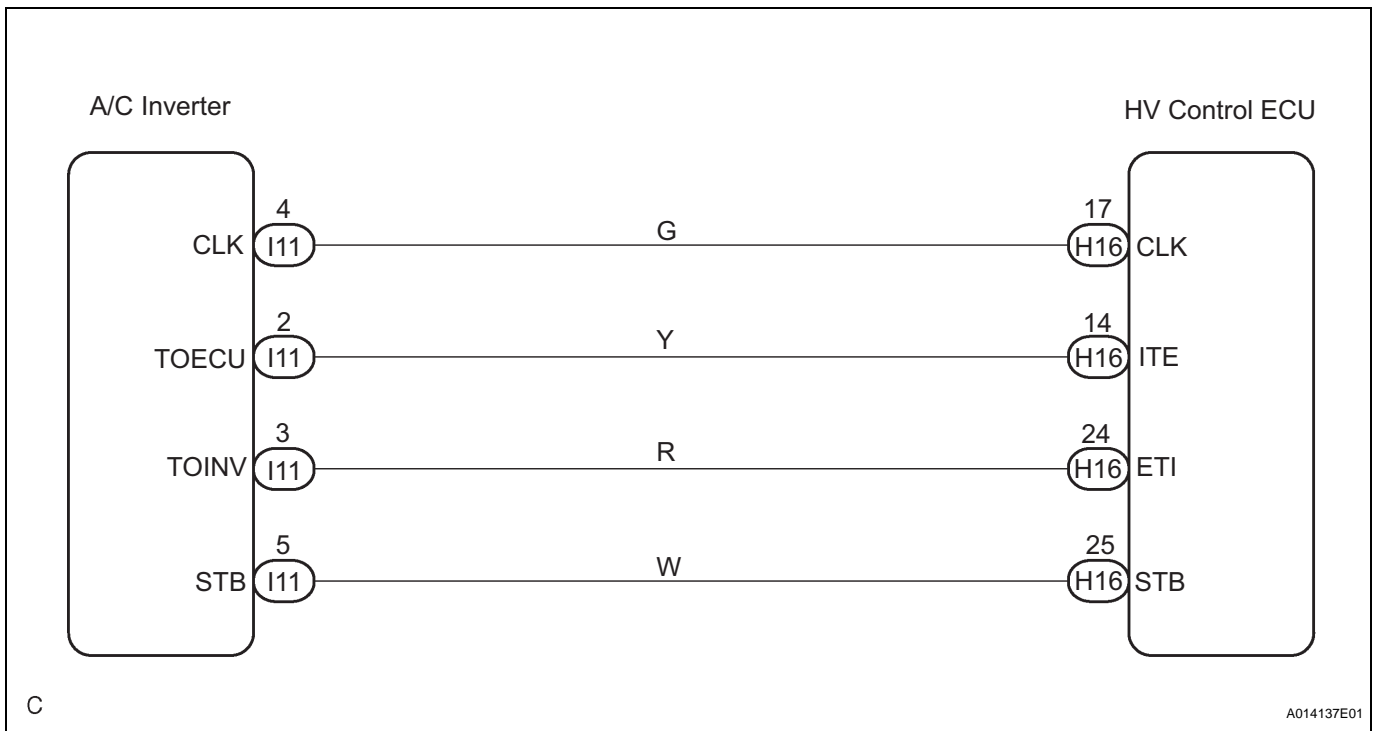

HV

INSPECTION PROCEDURE

1 CHECK HARNESS AND CONNECTOR (HYBRID VEHICLE CONTROL ECU - A/C INVERTER)

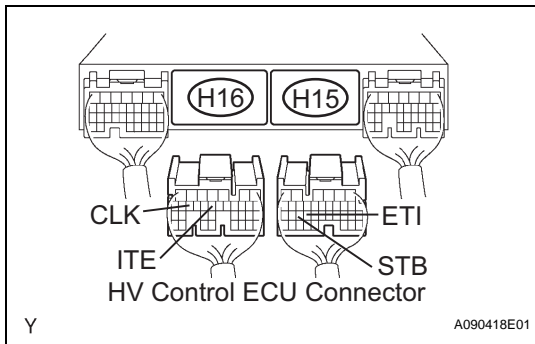

(a) Disconnect the H15 and H16 HV control ECU connectors.

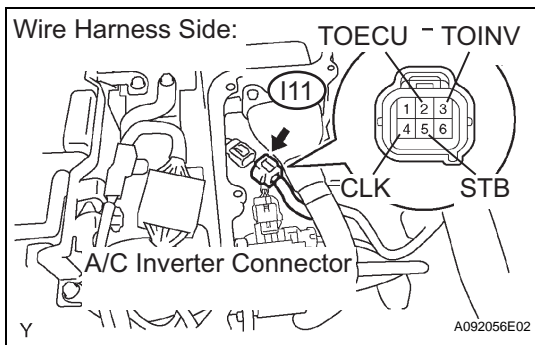

- (b) Disconnect the I11 A/C inverter connector.
- (c) Turn the power switch ON (IG).
- (d) Measure the voltage between the terminals of the HV control ECU connector and body ground.

Standard voltage

Tester Connection	Specified Condition
CLK (H16-17) - Body ground	Below 1 V
ITE (H16-14) - Body ground	Below 1 V
ETI (H15-24) - Body ground	Below 1 V
STB (H15-25) - Body ground	Below 1 V

- (e) Turn the power switch OFF.
- (f) Measure the resistance between the wire harness side connectors.

Standard resistance (Check for open)

Tester Connection	Specified Condition
CLK (H16-17) - CLK (I11-4)	Below 1 Ω
ITE (H16-14) - TOECU (I11-2)	Below 1 Ω
ETI (H15-24) - TOINV (I11-3)	Below 1 Ω
STB (H15-25) - STB (I11-5)	Below 1 Ω

Standard resistance (Check for short)

Tester Connection	Specified Condition
CLK (H16-17) or CLK (I11-4) - Body ground	10 kΩ or higher
ITE (H16-14) or TOECU (I11-2) - Body ground	10 kΩ or higher
ETI (H15-24) or TOINV (I11-3) - Body ground	10 kΩ or higher
STB (H15-25) or STB (I11-5) - Body ground	10 kΩ or higher

- (g) Reconnect the A/C inverter connector.
- (h) Reconnect the HV control ECU connectors.

NG REPAIR OR REPLACE HARNESS OR CONNECTOR

OK

REPLACE INVERTER WITH CONVERTER ASSEMBLY

DTC	P3108-537	A/C Amplifier Communication Circuit Malfunction
------------	------------------	--

DESCRIPTION

Refer to DTC 3108 (INF 535) (see page [HV-491](#)).

DTC No.	INF Code	DTC Detection Condition	Trouble Area
P3108	537	Air conditioning amplifier malfunction	<ul style="list-style-type: none"> Air conditioning amplifier

INSPECTION PROCEDURE

If the information (INF) code is present, replace the air conditioning amplifier.

1	REPLACE AIR CONDITIONING AMPLIFIER
----------	---

NEXT

COMPLETED

DTC	P3108-594	A/C Amplifier Communication Circuit Malfunction
------------	------------------	--

DESCRIPTION**HINT:**

DTC P3108 (INF 594) is one of the DTCs that indicate CAN communication malfunction.

Since the air conditioning amplifier is connected to BEAN (Body Electronics Area Network), the HV control ECU communicates with it using CAN (Controller Area Network) communication via the gateway ECU.

DTC No.	INF Code	DTC Detection Condition	Trouble Area
P3108	594	CAN communication malfunction	• CAN communication

INSPECTION PROCEDURE

1	READ OUTPUT DTC (CODES ALL)
----------	------------------------------------

- (a) Connect the intelligent tester to the DLC3.
- (b) Turn the power switch ON (IG).
- (c) Turn the intelligent tester ON.
- (d) Enter the following menus: DIAGNOSIS / OBD/MOBD / CODES (All).
- (e) Read and record CAN communication malfunction DTCs.

HINT:

When DTCs other than CAN communication malfunction DTCs are output simultaneously, first correct the CAN communication problem, and then perform troubleshooting for other DTCs.

GO

HV

GO TO CAN COMMUNICATION SYSTEM

DTC	P3110-223	IGCT Relay Malfunction
------------	------------------	-------------------------------

DTC	P3110-527	HV Main Relay Malfunction
------------	------------------	----------------------------------

DESCRIPTION

The HV control ECU monitors the IGCT relay and IG2 relay to detect malfunction.

DTC No.	INF Code	DTC Detection Condition	Trouble Area
P3110	223	IGCT relay is always closed	<ul style="list-style-type: none"> Wire harness or connector Integration relay (IGCT relay)
P3110	527	IG2 logical inconsistency	<ul style="list-style-type: none"> Wire harness or connector Integration relay (IG2 relay)

WIRING DIAGRAM

Refer to the wiring diagram for the IG2 relay (see page HV-184).

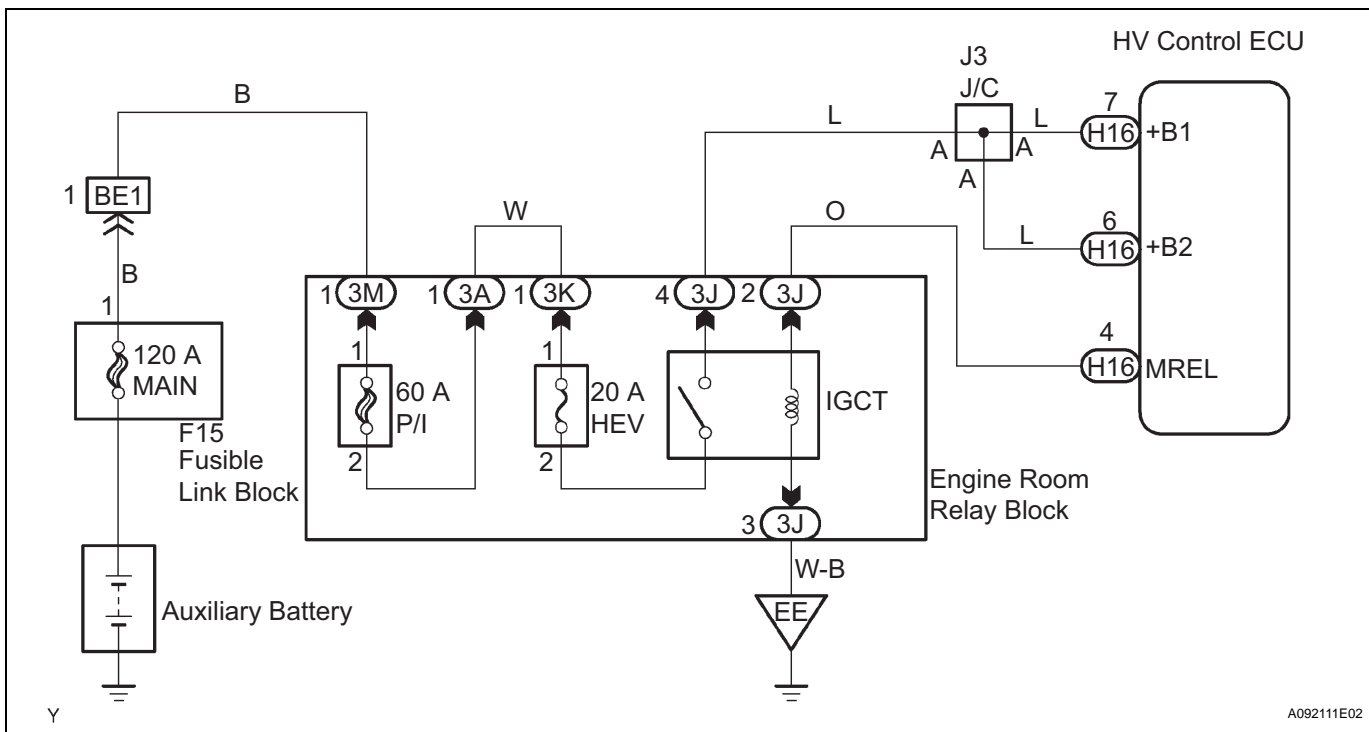

INSPECTION PROCEDURE

HINT:

If there is a battery voltage at the +B, MREL or IG2SW terminal of the HV control ECU even though the power switch is turned OFF, the circuit is shorted to the +B power supply.

1 INSPECT INTEGRATION RELAY (IGCT RELAY AND IG2 RELAY)

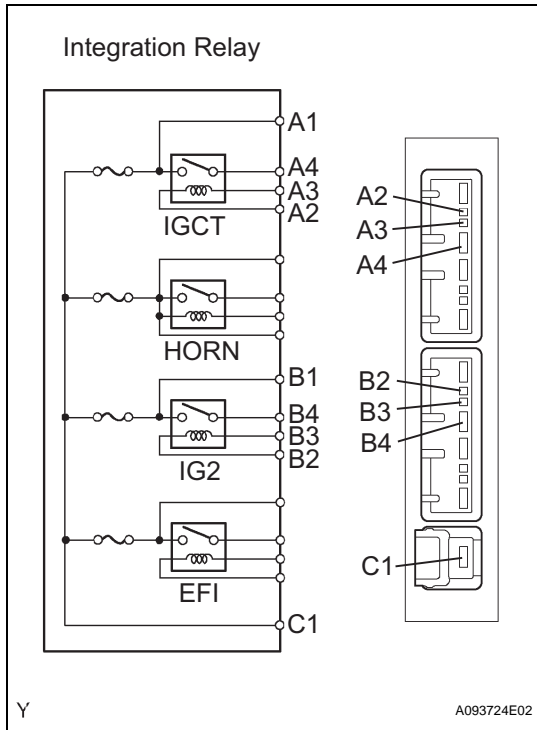

- (a) Remove the integration relay from the engine room relay block.
- (b) Inspect the IGCT relay.
 - (1) Measure the resistance between the terminals of the integration relay.

Standard resistance

Tester Connection	Specified Condition
A4 - C1	10 kΩ or higher
A4 - C1	Below 1 Ω (Apply battery voltage to terminals A2 and A3)

- (c) Inspect the IG2 relay.
 - (1) Measure the resistance between the terminals of the integration relay.

Standard resistance

Tester Connection	Specified Condition
B4 - C1	10 kΩ or higher
B4 - C1	Below 1 Ω (Apply battery voltage to terminals B2 and B3)

NG → **REPLACE INTEGRATION RELAY (IGCT RELAY OR IG2 RELAY)**

OK

REPAIR OR REPLACE HARNESS AND CONNECTOR AFTER INSPECTION (HV CONTROL ECU - INTEGRATION RELAY)

DTC	P3137-348	Collision Sensor Low Input
------------	------------------	-----------------------------------

DTC	P3138-349	Collision Sensor High Input
------------	------------------	------------------------------------

DESCRIPTION

The HV control ECU checks the line connection of the circuit breaker sensor (collision sensor) signal and gives warning to the driver if malfunction is detected.

DTC No.	INF Code	DTC Detection Condition	Trouble Area
P3137	348	GND short in No. 1 circuit breaker sensor circuit	<ul style="list-style-type: none"> • Wire harness or connector • No. 1 circuit breaker sensor
P3138	349	Open or +B short in No. 1 circuit breaker sensor circuit	<ul style="list-style-type: none"> • Wire harness or connector • No. 1 circuit breaker sensor

WIRING DIAGRAM

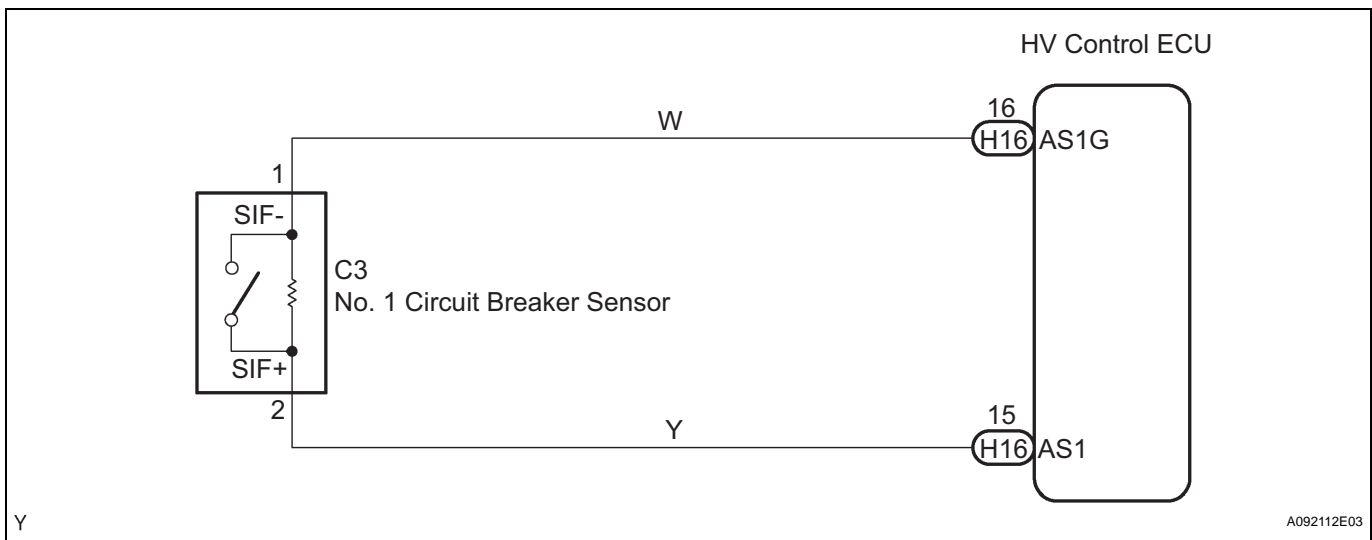

HV

INSPECTION PROCEDURE

1	CHECK HARNESS AND CONNECTOR (HYBRID VEHICLE CONTROL ECU - NO. 1 CIRCUIT BREAKER SENSOR)
----------	--

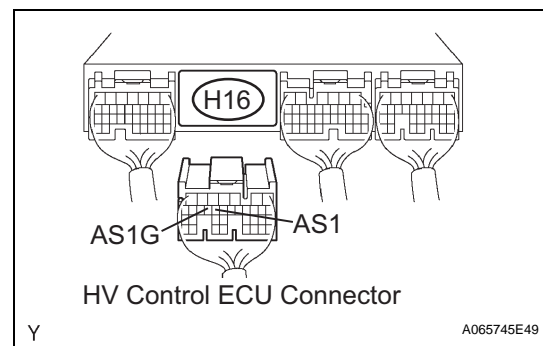

(a) Disconnect the H16 HV control ECU connector.

Y

A065745E49

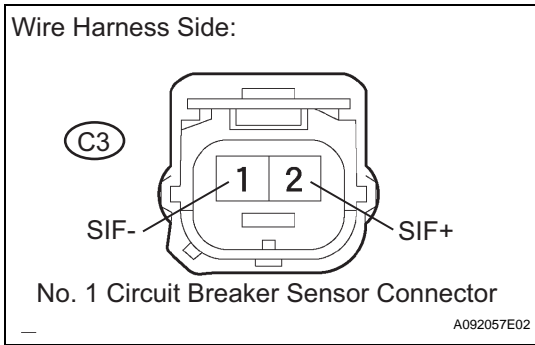

- (b) Disconnect the C3 No. 1 circuit breaker sensor connector.
- (c) Turn the power switch ON (IG).
- (d) Measure the voltage between the terminals of the HV control ECU connector and body ground.

Standard voltage

Tester Connection	Specified Condition
AS1 (H16-15) - Body ground	Below 1 V
AS1G (H16-16) - Body ground	Below 1 V

- (e) Turn the power switch OFF.
- (f) Measure the resistance between the wire harness side connectors.

Standard resistance (Check for open)

Tester Connection	Specified Condition
AS1 (H16-15) - SIF+ (C3-2)	Below 1 Ω
AS1G (H16-16) - SIF- (C3-1)	Below 1 Ω

Standard resistance (Check for short)

Tester Connection	Specified Condition
AS1 (H16-15) or SIF+ (C3-2) - Body ground	10 kΩ or higher
AS1G (H16-16) or SIF- (C3-1) - Body ground	10 kΩ or higher

- (g) Reconnect the No. 1 circuit breaker sensor connector.
- (h) Reconnect the HV control ECU connector.

NG **REPAIR OR REPLACE HARNESS OR CONNECTOR**

OK

REPLACE NO. 1 CIRCUIT BREAKER SENSOR

HV

DTC	P3221-314	Generator Inverter Temperature Sensor Circuit Range / Performance
------------	------------------	--

DTC	P3221-315	Generator Inverter Temperature Sensor Circuit Range / Performance
------------	------------------	--

DESCRIPTION

Refer to DTC P3222 (INF 313) (see page [HV-505](#)).

DTC No.	INF Code	DTC Detection Condition	Trouble Area
P3221	314	Sudden change in generator inverter temperature sensor output	<ul style="list-style-type: none"> • Wire harness or connector • Inverter cooling system • Water pump with motor assembly • Cooling fan motor • No. 2 cooling fan motor • Inverter with converter assembly
P3221	315	Generator inverter temperature sensor output deviation	<ul style="list-style-type: none"> • Wire harness or connector • Inverter cooling system • Water pump with motor assembly • Cooling fan motor • No. 2 cooling fan motor • Inverter with converter assembly

WIRING DIAGRAM

Refer to DTC P3222 (INF 313) (see page [HV-505](#)).

INSPECTION PROCEDURE

HV

CAUTION:

- Before inspecting the high-voltage system, take safety precautions to prevent electrical shocks, such as wearing insulated gloves and removing the service plug grip. After removing the service plug grip, put it in your pocket to prevent other technicians from reconnecting it while you are servicing the high-voltage system.
- After disconnecting the service plug grip, wait for at least 5 minutes before touching any of the high-voltage connectors or terminals.

HINT:

At least 5 minutes are required to discharge the high-voltage condenser inside the inverter.

1	CHECK QUANTITY OF HV COOLANT
----------	-------------------------------------

- (a) Check that there is a sufficient amount of coolant for the inverter.

OK:

There is a sufficient amount of coolant for the inverter

NG	ADD HV COOLANT
-----------	-----------------------

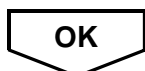

2 CHECK COOLANT HOSE

- (a) Check that the hoses of the cooling system are not bent or clogged (refer to the cooling system [see page HV-346]).

OK:

The hoses of the cooling system are not bent or clogged

NG

CORRECT TO NORMAL CONDITION

OK

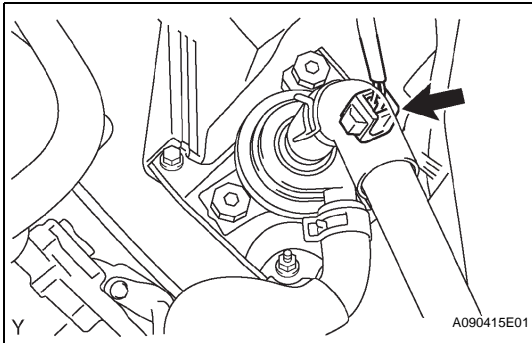
3 CHECK CONNECTION CONDITION OF WATER PUMP CONNECTOR (LOOSENESS AND POOR CONTACT)

- (a) Check the connection condition of the water pump connector.

OK:

Connector has been connected securely and there is no poor connection.

NG

CONNECT SECURELY

OK

4 CHECK WATER PUMP WITH MOTOR ASSEMBLY

- (a) Turn the power switch ON (IG).
 (b) Check the operation of the water pump.

OK:

Coolant is sloshing in the reservoir tank

NG

REPLACE WATER PUMP WITH MOTOR ASSEMBLY

OK

5 CHECK CONNECTION CONDITION OF COOLING FAN MOTOR CONNECTOR (LOOSENESS AND POOR CONTACT)

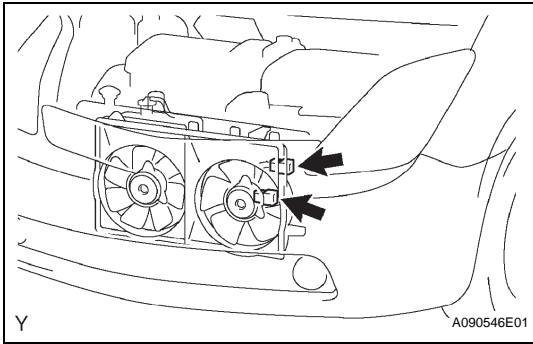

(a) Check the connection condition of the cooling fan motor connectors.

OK:

Connectors have been connected securely and there is no poor connection.

NG **CONNECT SECURELY**

OK

6 INSPECT COOLING FAN MOTOR

(a) Inspect the cooling fan motor (see page [CO-5](#)).

NG **REPLACE COOLING FAN MOTOR AND ADD ENGINE COOLANT**

OK

7 INSPECT NO. 2 COOLING FAN MOTOR

(a) Inspect the No. 2 cooling fan motor (see page [CO-5](#)).

NG **REPLACE NO. 2 COOLING FAN MOTOR AND ADD ENGINE COOLANT**

OK

8 CHECK CONNECTION CONDITION OF HYBRID VEHICLE CONTROL ECU CONNECTOR (LOOSENESS AND POOR CONTACT)

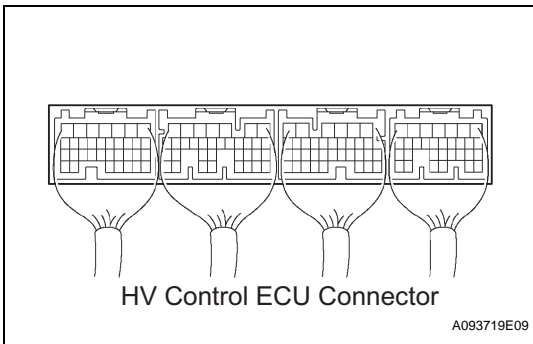

(a) Check the connection condition of all the connectors at the HV control ECU.

OK:

Connectors have been connected securely and there is no poor connection.

NG **CONNECT SECURELY**

OK

HV

9 CHECK CONNECTION CONDITION OF INVERTER CONNECTOR (LOOSENESS AND POOR CONTACT)

CAUTION:

Wear insulated gloves before performing the following operation.

- Turn the power switch OFF.
- Remove the service plug grip (see page [HB-154](#)).

NOTICE:

Turning the power switch ON (READY) with the service plug grip removed could cause malfunction. Therefore, never turn the power switch ON (READY) in this state.

- Remove the inverter cover (see page [HV-531](#)).
- Check the connection condition of the I9 and I10 inverter connectors.

OK:

Connectors have been connected securely and there is no poor connection.

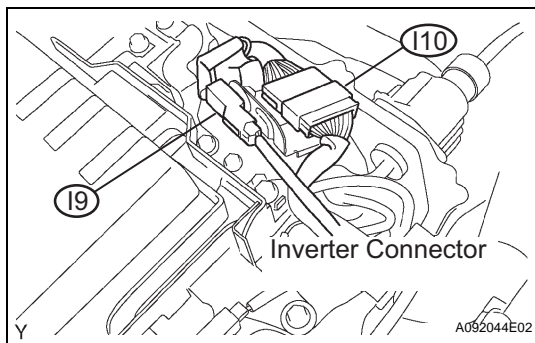

OK

NG

CONNECT SECURELY

10 CHECK HARNESS AND CONNECTOR (HYBRID VEHICLE CONTROL ECU - INVERTER)

CAUTION:

Wear insulated gloves before performing the following operation.

- Check that the service plug grip and inverter cover have been removed.
- Disconnect the H15 HV control ECU connector.

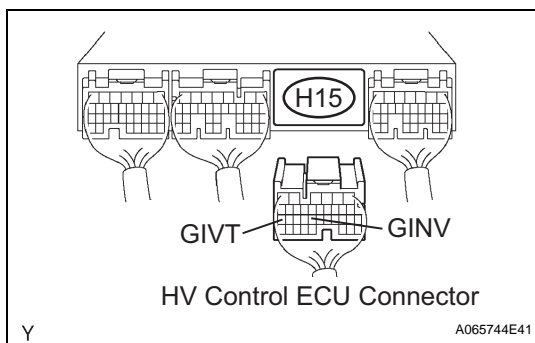

HV

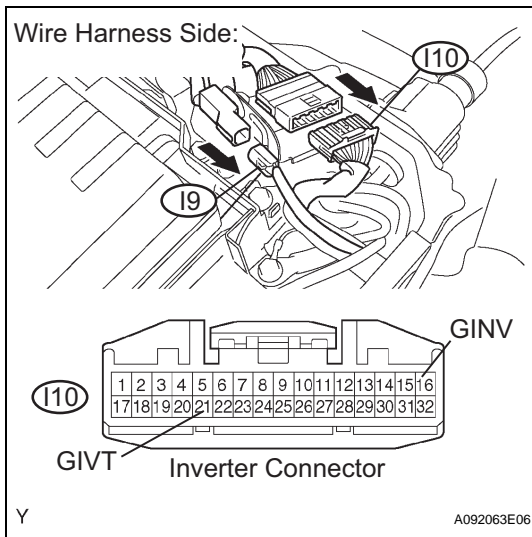

- (c) Disconnect the I9 and I10 inverter connectors.
- (d) Turn the power switch ON (IG).
HINT:
DTCs for the interlock switch system are output when turning the power switch ON (IG) with both service plug grip and inverter cover removed.
- (e) Measure the voltage between the terminals of the HV control ECU connector and body ground.

Standard voltage

Tester Connection	Specified Condition
GIVT (H15-27) - Body ground	Below 1 V
GINV (H15-23) - Body ground	Below 1 V

- (f) Turn the power switch OFF.
- (g) Measure the resistance between the wire harness side connectors.

Standard resistance (Check for open)

Tester Connection	Specified Condition
GIVT (H15-27) - GIVT (I10-21)	Below 1 Ω
GINV (H15-23) - GINV (I10-16)	Below 1 Ω

Standard resistance (Check for short)

Tester Connection	Specified Condition
GIVT (H15-27) or GIVT (I10-21) - Body ground	10 kΩ or higher
GINV (H15-23) or GINV (I10-16) - Body ground	10 kΩ or higher

- (h) Reconnect the inverter connectors.
- (i) Reconnect the HV control ECU connector.
- (j) Reinstall the inverter cover (see page HV-538).
- (k) Reinstall the service plug grip (see page HB-154).

NG

REPAIR OR REPLACE HARNESS OR CONNECTOR

OK

REPLACE INVERTER WITH CONVERTER ASSEMBLY

HV

DTC	P3222-313	Generator Inverter Temperature Sensor Circuit High / Low
------------	------------------	---

DTC	P3223-312	Generator Inverter Temperature Sensor Circuit High
------------	------------------	---

DESCRIPTION

The HV control ECU uses a temperature sensor, which is built into the inverter, to detect the temperature of the generator inverter. The same cooling system that is routed to the MG1 and MG2 cools the inverter. This cooling system is independent from the engine cooling system.

The characteristic of the generator inverter temperature sensor is the same as the boost converter temperature sensor (see page HV-350).

The HV control ECU limits the load based on the signals transmitted by the generator inverter temperature sensor, in order to check the effectiveness of the inverter cooling system and prevent the inverter from overheating. Furthermore, the HV control ECU detects a malfunction in the wiring of the generator inverter temperature sensor, as well as in the sensor itself.

DTC No.	INF Code	DTC Detection Condition	Trouble Area
P3222	313	Open or GND short in generator inverter temperature sensor circuit	<ul style="list-style-type: none"> Wire harness or connector Inverter with converter assembly HV control ECU
P3223	312	+B short in generator inverter temperature sensor circuit	<ul style="list-style-type: none"> Wire harness or connector Inverter with converter assembly HV control ECU

HINT:

After confirming DTC P3222 (INF 313) or P3223 (INF 312), confirm MG1 INVERT TEMP in DIAGNOSIS / OBD/MOBD / HV ECU / DATA LIST using the intelligent tester.

Temperature Displayed	Malfunction
-50°C (-58°F)	+B short circuit
205°C (401°F)	Open or GND short circuit

HV

WIRING DIAGRAM

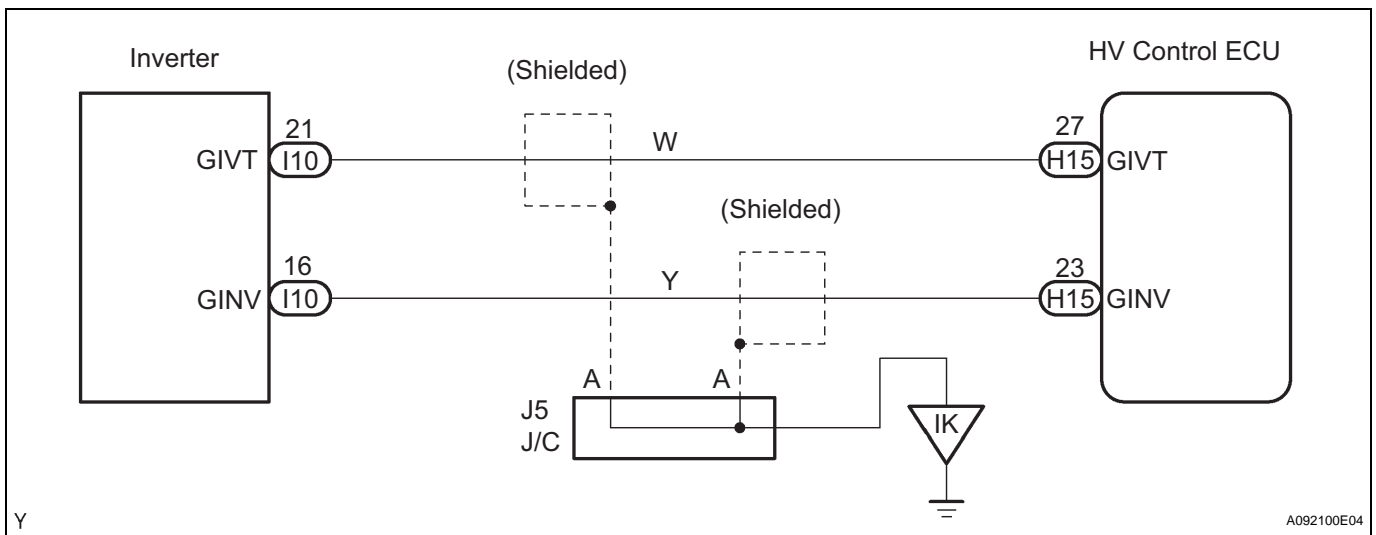

Y

A092100E04

INSPECTION PROCEDURE

CAUTION:

- Before inspecting the high-voltage system, take safety precautions to prevent electrical shocks, such as wearing insulated gloves and removing the service plug grip. After removing the service plug grip, put it in your pocket to prevent other technicians from reconnecting it while you are servicing the high-voltage system.
- After disconnecting the service plug grip, wait for at least 5 minutes before touching any of the high-voltage connectors or terminals.

HINT:

At least 5 minutes are required to discharge the high-voltage condenser inside the inverter.

1	READ VALUE OF INTELLIGENT TESTER (MG1 INVERT TEMP)
----------	---

- (a) Connect the intelligent tester to the DLC3.
- (b) Turn the power switch ON (IG).
- (c) Turn the intelligent tester ON.
- (d) Enter the following menus: DIAGNOSIS / OBD/MOBD / HV ECU / DATA LIST.
- (e) Read the MG1 INVERT TEMP value.

Result

Temperature Displayed	Proceed to
-50°C (-58°F)	A
205°C (401°F)	B
-49°C to 204°C (-57°F to 400°F)	C

HINT:

- If there is a +B short circuit, the intelligent tester indicates -50°C (-58°F).
- If there is an open or GND short circuit, the intelligent tester indicates 205°C (401°F).

HV

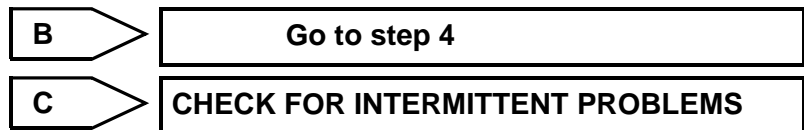

2	READ VALUE OF INTELLIGENT TESTER (CHECK FOR +B SHORT IN WIRE HARNESS)
----------	--

CAUTION:

Wear insulated gloves before performing the following operation.

- (a) Turn the power switch OFF.
- (b) Remove the service plug grip (see page [HB-154](#)).

NOTICE:

Turning the power switch ON (READY) with the service plug grip removed could cause malfunction. Therefore, never turn the power switch ON (READY) in this state.

- (c) Remove the inverter cover (see page [HV-531](#)).

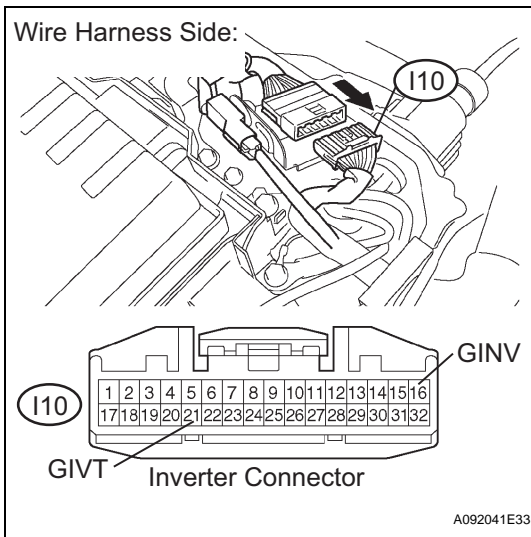

(d) Disconnect the I10 inverter connector.

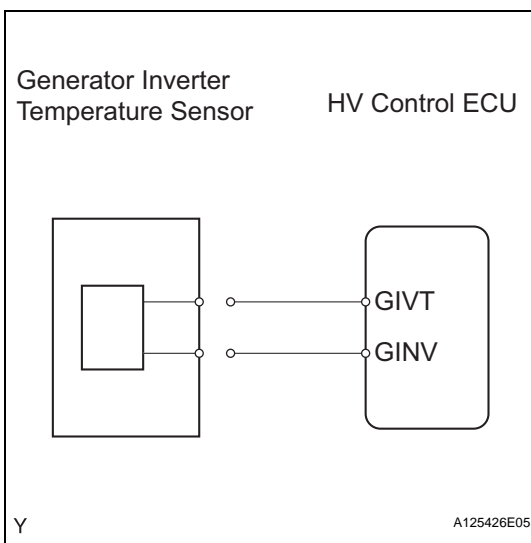

(e) Turn the power switch ON (IG).

HINT:

DTCs for the interlock switch system are output when turning the power switch ON (IG) with both service plug grip and inverter cover removed.

(f) Enter the following menus: DIAGNOSIS / OBD/MOBD / HV ECU / DATA LIST.

(g) Read the MG1 INVERT TEMP value.

OK:

205°C (401°F)

(h) Turn the power switch OFF.

(i) Reconnect the inverter connector.

(j) Reinstall the inverter cover (see page HV-538).

(k) Reinstall the service plug grip (see page HB-154).

OK

REPLACE INVERTER WITH CONVERTER ASSEMBLY

NG

3 READ VALUE OF INTELLIGENT TESTER (CHECK FOR +B SHORT IN HYBRID VEHICLE CONTROL ECU)

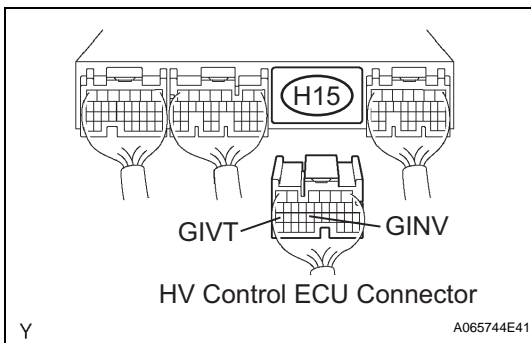

(a) Disconnect the H15 HV control ECU connector.

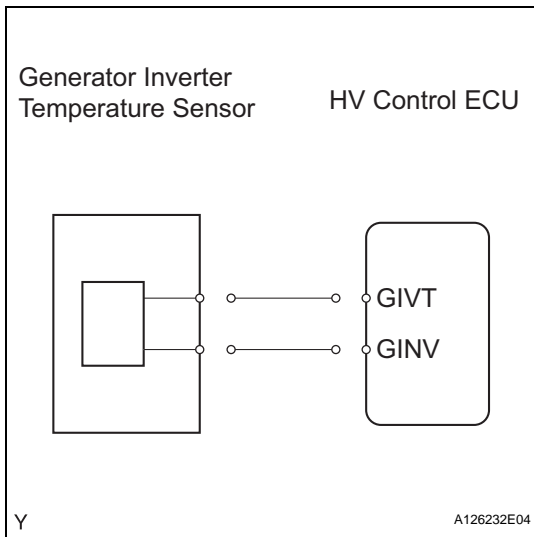

(b) Turn the power switch ON (IG).

HINT:

DTCs for the interlock switch system are output when turning the power switch ON (IG) with both service plug grip and inverter cover removed.

(c) Enter the following menus: DIAGNOSIS / OBD/MOBD / HV ECU / DATA LIST.

(d) Read the MG1 INVERT TEMP value.

OK:

205°C (401°F)

(e) Reconnect the HV control ECU connector.

NG → **REPLACE HYBRID VEHICLE CONTROL ECU**

OK

REPAIR OR REPLACE HARNESS OR CONNECTOR

4 CHECK HARNESS AND CONNECTOR (HYBRID VEHICLE CONTROL ECU - INVERTER)

CAUTION:

Wear insulated gloves before performing the following operation.

(a) Turn the power switch OFF.

(b) Remove the service plug grip (see page [HB-154](#)).

NOTICE:

Turning the power switch ON (READY) with the service plug grip removed could cause malfunction. Therefore, never turn the power switch ON (READY) in this state.

(c) Remove the inverter cover (see page [HV-531](#)).

(d) Disconnect the H15 HV control ECU connector.

HV

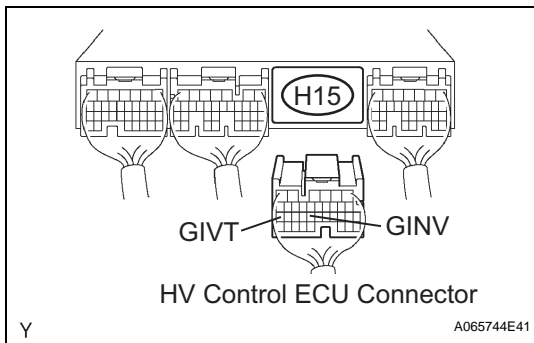

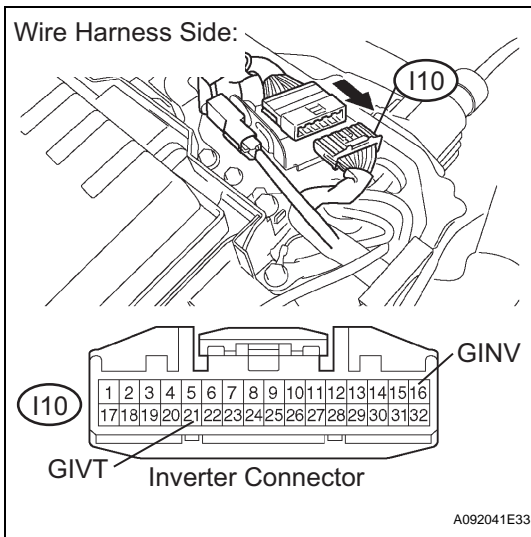

- (e) Disconnect the I10 inverter connector.
- (f) Measure the resistance between the wire harness side connectors.

Standard resistance (Check for open)

Tester Connection	Specified Condition
GIVT (H15-27) - GIVT (I10-21)	Below 1 Ω
GINV (H15-23) - GINV (I10-16)	Below 1 Ω

Standard resistance (Check for short)

Tester Connection	Specified Condition
GIVT (H15-27) or GIVT (I10-21) - Body ground	10 kΩ or higher
GINV (H15-23) or GINV (I10-16) - Body ground	10 kΩ or higher

- (g) Reconnect the inverter connector.
- (h) Reconnect the HV control ECU connector.
- (i) Reinstall the inverter cover (see page HV-538).
- (j) Reinstall the service plug grip (see page HB-154).

NG → **REPAIR OR REPLACE HARNESS OR CONNECTOR**

OK

5 CHECK HYBRID VEHICLE CONTROL ECU (GIVT VOLTAGE)

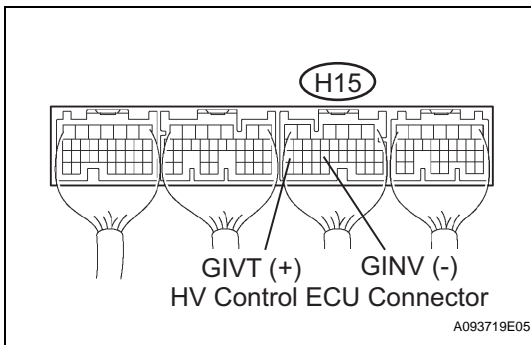

- (a) Turn the power switch ON (IG).
HINT:
DTCs for the interlock switch system are output when turning the power switch ON (IG) with both service plug grip and inverter cover removed.
- (b) Measure the voltage between the terminals of the H15 HV control ECU connector.

Standard voltage

Tester Connection	Specified Condition
GIVT (H15-27) - GINV (H15-23)	2.0 to 4.5 V

NG → **REPLACE INVERTER WITH CONVERTER ASSEMBLY**

OK

REPLACE HYBRID VEHICLE CONTROL ECU

HV

DTC	P3226-562	DC/DC Boost Converter Temperature Sensor
DTC	P3226-563	DC/DC Boost Converter Temperature Sensor

DESCRIPTION

Refer to DTC P0A94 (INF 583) (see page [HV-395](#)).

DTC No.	INF Code	DTC Detection Condition	Trouble Area
P3226	562	Sudden change in boost converter temperature sensor output	<ul style="list-style-type: none"> Wire harness or connector Inverter cooling system Water pump with assembly Cooling fan motor No. 2 cooling fan motor Inverter with converter assembly
P3226	563	Boost converter temperature sensor output deviation	<ul style="list-style-type: none"> Wire harness or connector Inverter cooling system Water pump with motor assembly Cooling fan motor No. 2 cooling fan motor Inverter with converter assembly

WIRING DIAGRAM

Refer to DTC P0A94 (INF 583) (see page [HV-396](#)).

INSPECTION PROCEDURE

CAUTION:

- Before inspecting the high-voltage system, take safety precautions to prevent electrical shocks, such as wearing insulated gloves and removing the service plug grip. After removing the service plug grip, put it in your pocket to prevent other technicians from reconnecting it while you are servicing the high-voltage system.
- After disconnecting the service plug grip, wait for at least 5 minutes before touching any of the high-voltage connectors or terminals.

HINT:

At least 5 minutes are required to discharge the high-voltage condenser inside the inverter.

1	CHECK QUANTITY OF HV COOLANT
----------	-------------------------------------

- (a) Check that there is a sufficient amount of coolant for the inverter.

OK:

There is a sufficient amount of coolant for the inverter

NG

ADD HV COOLANT

OK

2	CHECK COOLANT HOSE
----------	---------------------------

- (a) Check that the hoses of the cooling system are not bent or clogged (refer to the cooling system [see page [HV-346](#)]).

OK:

The hoses of the cooling system are not bent or clogged

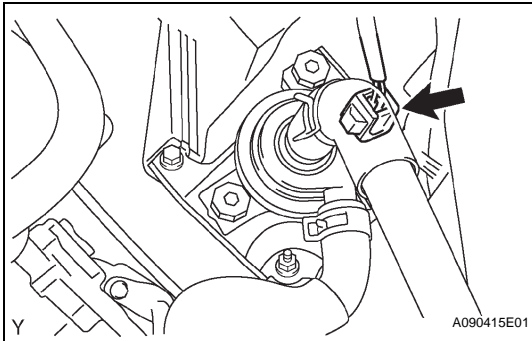
NG**CORRECT TO NORMAL CONDITION****OK****3****CHECK CONNECTION CONDITION OF WATER PUMP CONNECTOR (LOOSENESS AND POOR CONTACT)**

- (a) Check the connection condition of the water pump connector.

OK:

Connector has been connected securely and there is no poor connection.

NG**CONNECT SECURELY****OK****4****CHECK WATER PUMP WITH MOTOR ASSEMBLY**

- (a) Turn the power switch ON (IG).
 (b) Check the operation of the water pump.

OK:

Coolant is sloshing in the reservoir tank

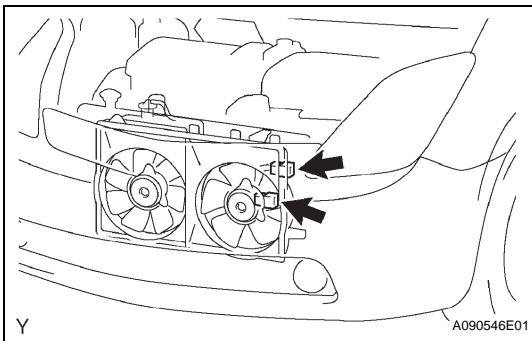
NG**REPLACE WATER PUMP WITH MOTOR ASSEMBLY****OK****5****CHECK CONNECTION CONDITION OF COOLING FAN MOTOR CONNECTOR (LOOSENESS AND POOR CONTACT)**

- (a) Check the connection condition of the cooling fan motor connectors.

OK:

Connectors have been connected securely and there is no poor connection.

NG**CONNECT SECURELY****OK****HV**

6 INSPECT COOLING FAN MOTOR

- (a) Inspect the cooling fan motor (see page
- [CO-5](#)
-).

NG**REPLACE COOLING FAN MOTOR AND ADD ENGINE COOLANT****OK****7 INSPECT NO. 2 COOLING FAN MOTOR**

- (a) Inspect the No. 2 cooling fan motor (see page
- [CO-5](#)
-).

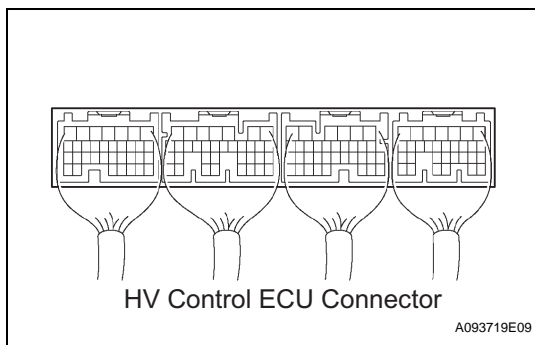
NG**REPLACE NO. 2 COOLING FAN MOTOR AND ADD ENGINE COOLANT****OK****8 CHECK CONNECTION CONDITION OF HYBRID VEHICLE CONTROL ECU CONNECTOR (LOOSENESS AND POOR CONTACT)**

- (a) Check the connection condition of all the connectors at the HV control ECU.

OK:**Connectors have been connected securely and there is no poor connection.****NG****CONNECT SECURELY****OK****9 CHECK CONNECTION CONDITION OF INVERTER CONNECTOR (LOOSENESS AND POOR CONTACT)****CAUTION:****Wear insulated gloves before performing the following operation.**

- (a) Turn the power switch OFF.
- (b) Remove the service plug grip (see page [HB-154](#)).

NOTICE:**Turning the power switch ON (READY) with the service plug grip removed could cause malfunction. Therefore, never turn the power switch ON (READY) in this state.**

- (c) Remove the inverter cover (see page [HV-531](#)).

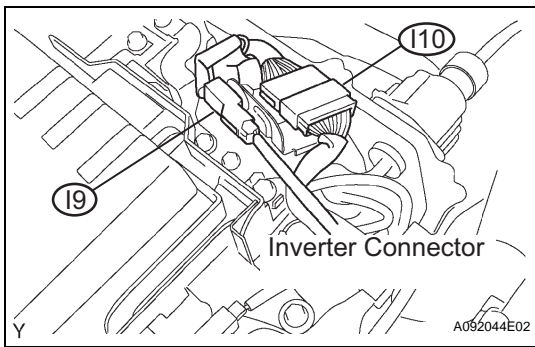

- (d) Check the connection condition of the I9 and I10 inverter connectors.

OK:

Connectors have been connected securely and there is no poor connection.

NG **CONNECT SECURELY**

OK

10 CHECK HARNESS AND CONNECTOR (HYBRID VEHICLE CONTROL ECU - INVERTER)

CAUTION:

Wear insulated gloves before performing the following operation.

- (a) Check that the service plug grip and inverter cover have been removed.
- (b) Disconnect the H16 HV control ECU connector.

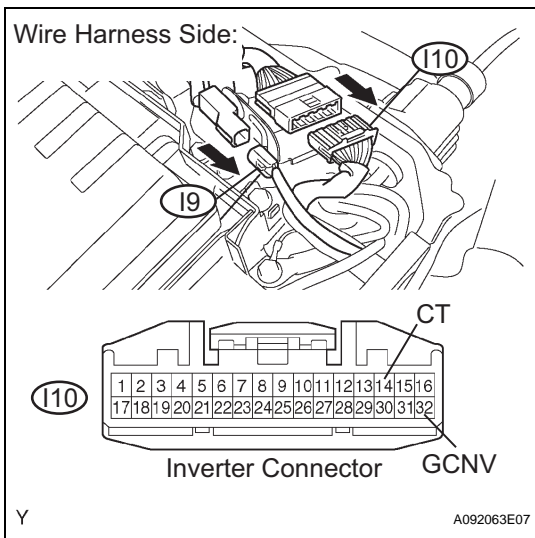
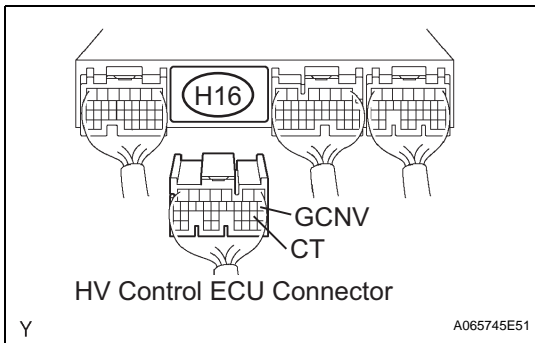

- (c) Disconnect the I9 and I10 inverter connectors.
- (d) Turn the power switch ON (IG).

HINT:

DTCs for the interlock switch system are output when turning the power switch ON (IG) with both service plug grip and inverter cover removed.

- (e) Measure the voltage between the terminals of the HV control ECU connector and body ground.

Standard voltage

Tester Connection	Specified Condition
CT (H16-21) - Body ground	Below 1 V
GCNV (H16-8) - Body ground	Below 1 V

- (f) Turn the power switch OFF.
- (g) Measure the resistance between the wire harness side connectors.

Standard resistance (Check for open)

Tester Connection	Specified Condition
CT (H16-21) - CT (I10-14)	Below 1 Ω
GCNV (H16-8) - GCNV (I10-32)	Below 1 Ω

Standard (Check for short)

HV

Tester Connection	Specified Condition
CT (H16-21) or CT (I10-14) - Body ground	10 k Ω or higher
GCVN (H16-8) or GCVN (I10-32) - Body ground	10 k Ω or higher

- (h) Reconnect the inverter connectors.
- (i) Reconnect the HV control ECU connector.
- (j) Reinstall the inverter cover (see page [HV-538](#)).
- (k) Reinstall the service plug grip (see page [HB-154](#)).

NG**REPAIR OR REPLACE HARNESS OR CONNECTOR****OK****REPLACE INVERTER WITH CONVERTER ASSEMBLY**

DTC	U0100-211	Lost Communication with ECM / PCM "A"
DTC	U0100-212	Lost Communication with ECM / PCM "A"
DTC	U0100-530	Lost Communication with ECM / PCM "A"
DTC	U0111-208	Lost Communication with Battery Energy Control Module "A"
DTC	U0111-531	Lost Communication with Battery Energy Control Module "A"
DTC	U0129-220	Lost Communication with Brake System Control Module
DTC	U0129-222	Lost Communication with Brake System Control Module
DTC	U0129-528	Lost Communication with Brake System Control Module
DTC	U0129-529	Lost Communication with Brake System Control Module
DTC	U0131-433	Lost Communication with Power Steering Control Module
DTC	U0131-434	Lost Communication with Power Steering Control Module
DTC	U0146-435	Lost Communication with Gateway "A"

DESCRIPTION

The HV control ECU transmits and receives signals to and from the ECM, battery ECU, skid control ECU, power steering ECU, and the gateway ECU via CAN (Controller Area Network) communication.

DTC No.	INF Code	DTC Detection Condition	Trouble Area
U0100	211	CAN communication problem between ECM and HV control ECU (no signal input)	<ul style="list-style-type: none"> CAN communication system
U0100	212	CAN communication problem between ECM and HV control ECU (transmission error)	<ul style="list-style-type: none"> CAN communication system

DTC No.	INF Code	DTC Detection Condition	Trouble Area
U0100	530	CAN communication problem between ECM and HV control ECU (CAN communication system malfunction)	• CAN communication system
U0111	208	CAN communication problem between battery ECU and HV control ECU (no signal input)	• CAN communication system
U0111	531	CAN communication problem between battery ECU and HV control ECU (CAN communication system malfunction)	• CAN communication system
U0129	220	CAN communication problem between skid control ECU and HV control ECU (no signal input)	• CAN communication system
U0129	222	CAN communication problem between skid control ECU and HV control ECU (CAN communication system malfunction)	• CAN communication system
U0129	528	CAN communication problem between skid control ECU and HV control ECU (transmission error)	• CAN communication system
U0129	529	CAN communication problem between skid control ECU and HV control ECU (regenerative torque malfunction)	• CAN communication system
U0131	433	CAN communication problem between power steering ECU and HV control ECU (no signal input)	• CAN communication system
U0131	434	CAN communication problem between power steering ECU and HV control ECU (CAN communication system malfunction)	• CAN communication system
U0146	435	CAN communication problem between gateway ECU and HV control ECU (no signal input)	• CAN communication system

MONITOR DESCRIPTION

If the HV control ECU detects a malfunction in the CAN communication with the ECM or battery ECU, it illuminates the MIL and sets a DTC.

MONITOR STRATEGY

U0100:

Related DTCs	U0100 (INF 211): Receiving check for the specific frame U0100 (INF 212): Sending data check U0100 (INF 530): Receiving check for the all frame
Required sensor / components	Main: ECM Sub: CAN bus line
Frequency of operation	Continuous
Duration	U0100 (INF 211, 212): 0.1 second or more U0100 (INF 530): 1.91 seconds or more
MIL operation	1 driving cycle
Sequence of operation	None

U0111:

Related DTCs	U0111 (INF 208): Receiving check for the specific frame U0111 (INF 531): Receiving check for the all frame
Required sensor / components	Main: Battery ECU Sub: CAN bus line
Frequency of operation	Continuous
Duration	U0111 (INF 208): 0.1 second or more U0111 (INF 531): 1.6 seconds or more
MIL operation	1 driving cycle
Sequence of operation	None

TYPICAL ENABLING CONDITIONS

The monitor will run whenever the following DTCs are not present	TOYOTA's intellectual property
Other conditions belong to TOYOTA's intellectual property	-

TYPICAL MALFUNCTION THRESHOLDS

CAN communication	Communication failure
-------------------	-----------------------

COMPONENT OPERATING RANGE

ECM	DTC U0100 (INF 211 / 212 / 530) is not detected
Battery ECU	DTC U0111 (INF 208 / 531) is not detected

INSPECTION PROCEDURE

1	READ OUTPUT DTC (CODES ALL)
----------	------------------------------------

HV

- (a) Connect the intelligent tester to the DLC3.
- (b) Turn the power switch ON (IG).
- (c) Turn the intelligent tester ON.
- (d) Enter the following menus: DIAGNOSIS / OBD/MOBD / CODES (All).
- (e) Read and record CAN communication malfunction DTCs.

Result:

Display (DTC Output)	Proceed to
U0100 (INF 211) or U0129 (INF 220)	A
U0100 (INF 211) and CAN communication malfunction DTCs	B
U0129 (INF 220) and CAN communication malfunction DTCs	B
P3108 (INF 594) and CAN communication malfunction DTCs	B

HINT:

- When DTCs other than CAN communication malfunction DTCs are output simultaneously, first correct the CAN communication problem, and then perform troubleshooting for other DTCs.
- DTC P3108 (INF 594) is one of the DTCs that indicates a CAN communication malfunction.

B GO TO CAN COMMUNICATION SYSTEM

A

2 CHECK TERMINAL OF ECM AND ECUS (+B1, +B2, CANH AND CANL TERMINALS)

(a) Check connection condition of each connector of the HV control ECU, ECM and battery ECU, as well as contact condition of each terminal shown in the table.

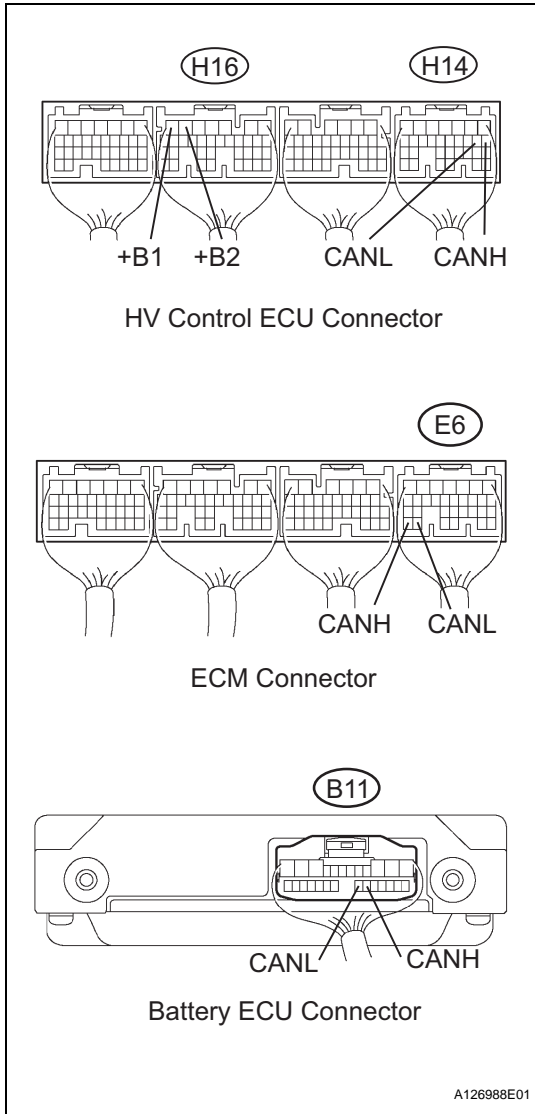

Type of ECU	Terminal No.	Symbols
HV control ECU	H16-7	+B1
HV control ECU	H16-6	+B2
HV control ECU	H14-8	CANH
HV control ECU	H14-9	CANL
ECM	E6-31	CANH
ECM	E6-30	CANL
Battery ECU	B11-18	CANH
Battery ECU	B11-19	CANL

OK:
Connectors have been connected securely and there is no poor contact on each terminal.

NG CONNECT SECURELY

OK

CHECK FOR INTERMITTENT PROBLEMS

HV

- (d) Do not carry any metal objects such as a mechanical pencil or a measuring tape that could fall and cause a short circuit.
- (e) After removing any high voltage wires, insulate them immediately with insulation tape.
- (f) Always tighten the high voltage screw terminals to the specified torque. Insufficient or excessive torque will cause malfunctions.
- (g) After finishing work on the high voltage systems and before reinstalling the service plug, reconfirm that you have not left any parts or tools lying around, that the high voltage terminals are tightened and that the connectors are connected.

COMPONENTS

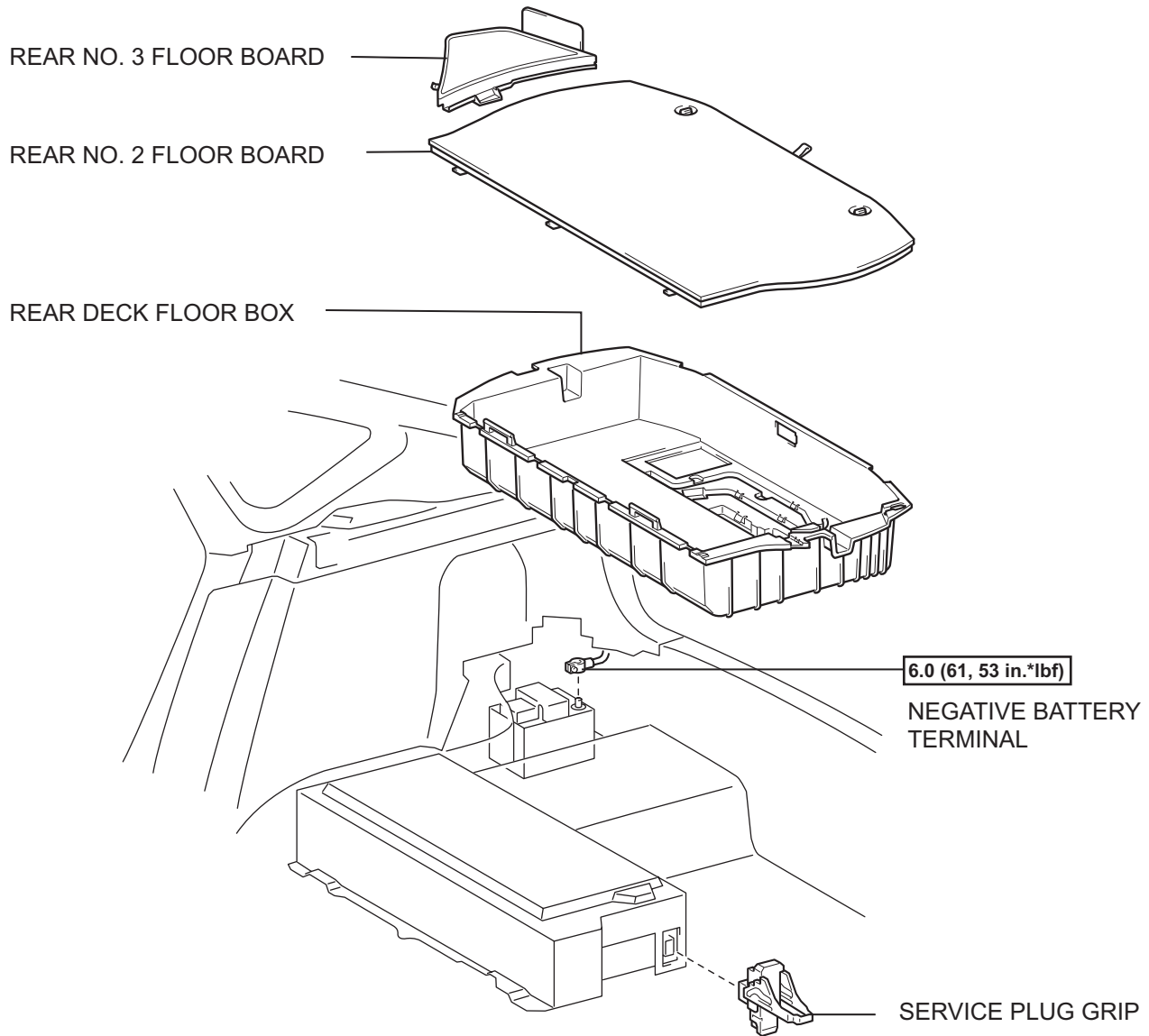

N*m (kgf*cm, ft.*lbf) : Specified torque

HV

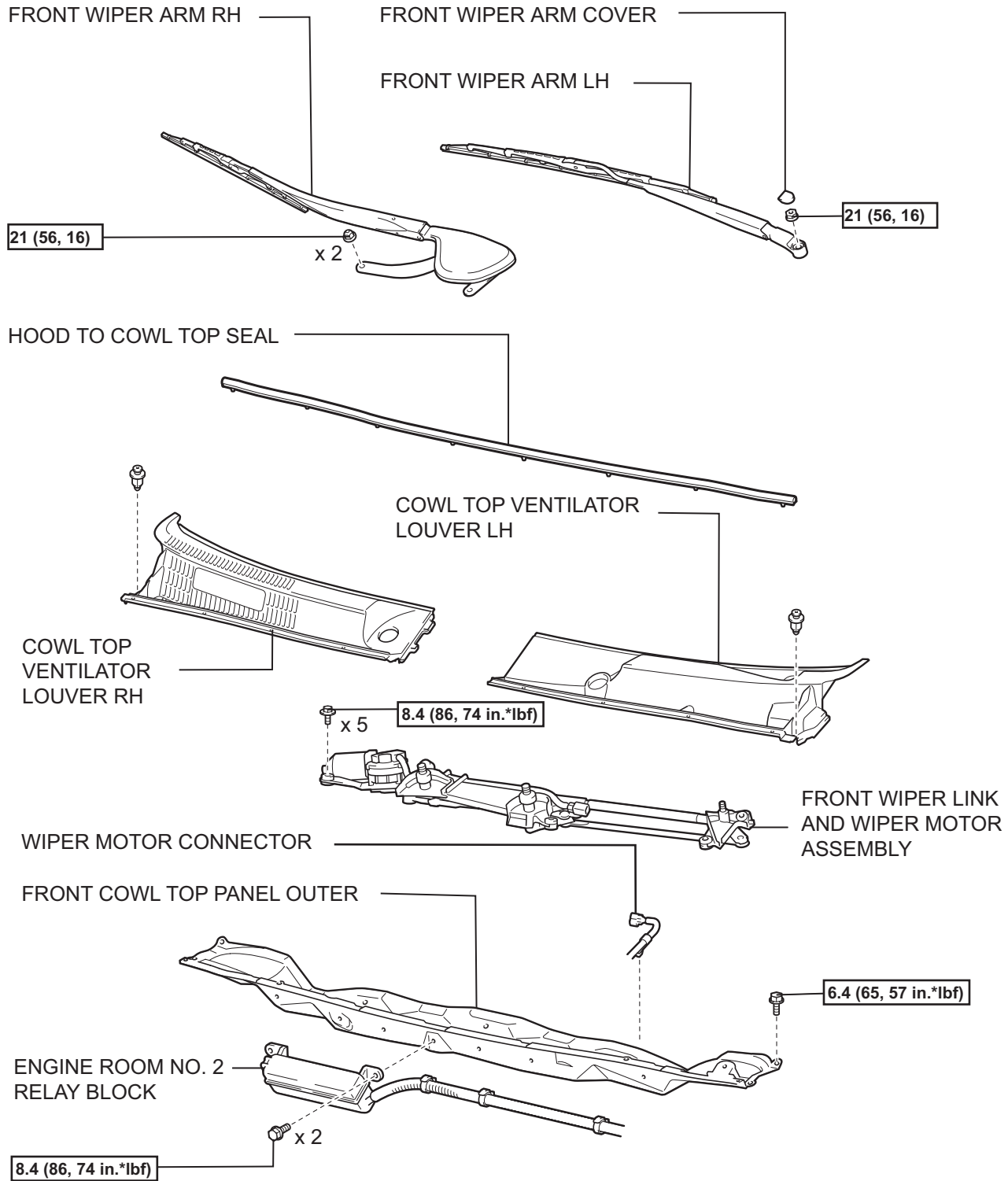

N*m (kgf*cm, ft.*lbf) : Specified torque

HV

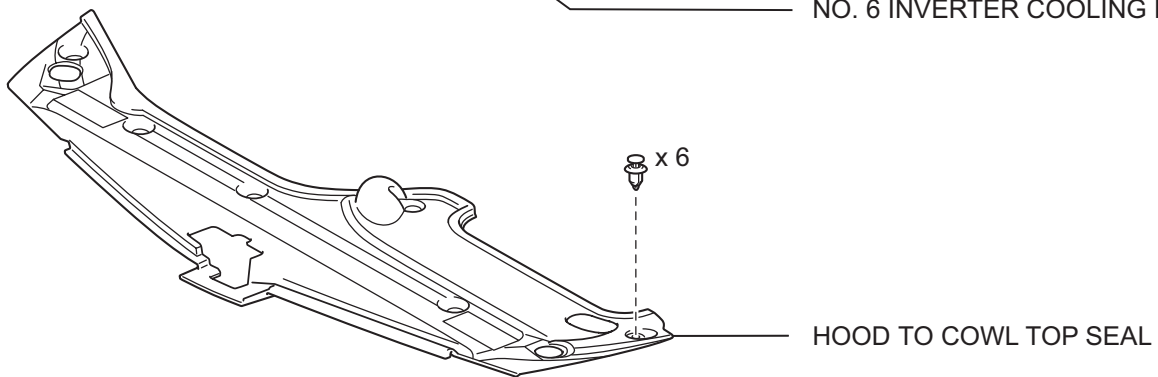
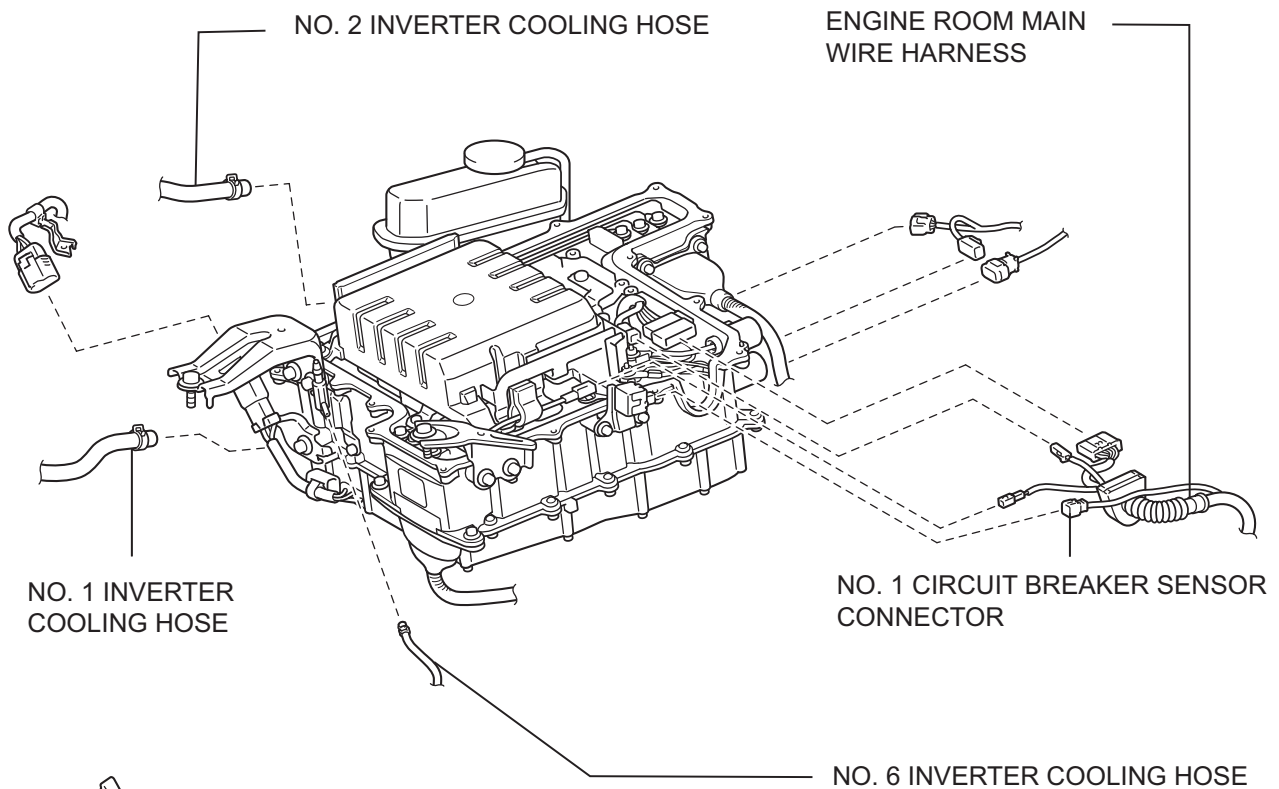
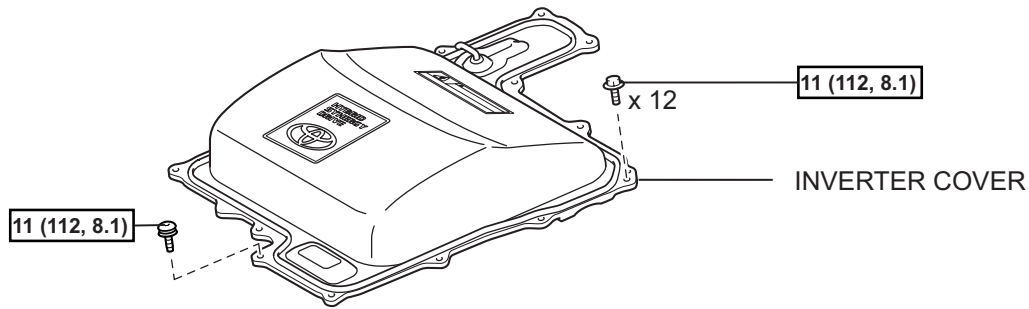

N*m (kgf*cm, ft.*lbf) : Specified torque

HV

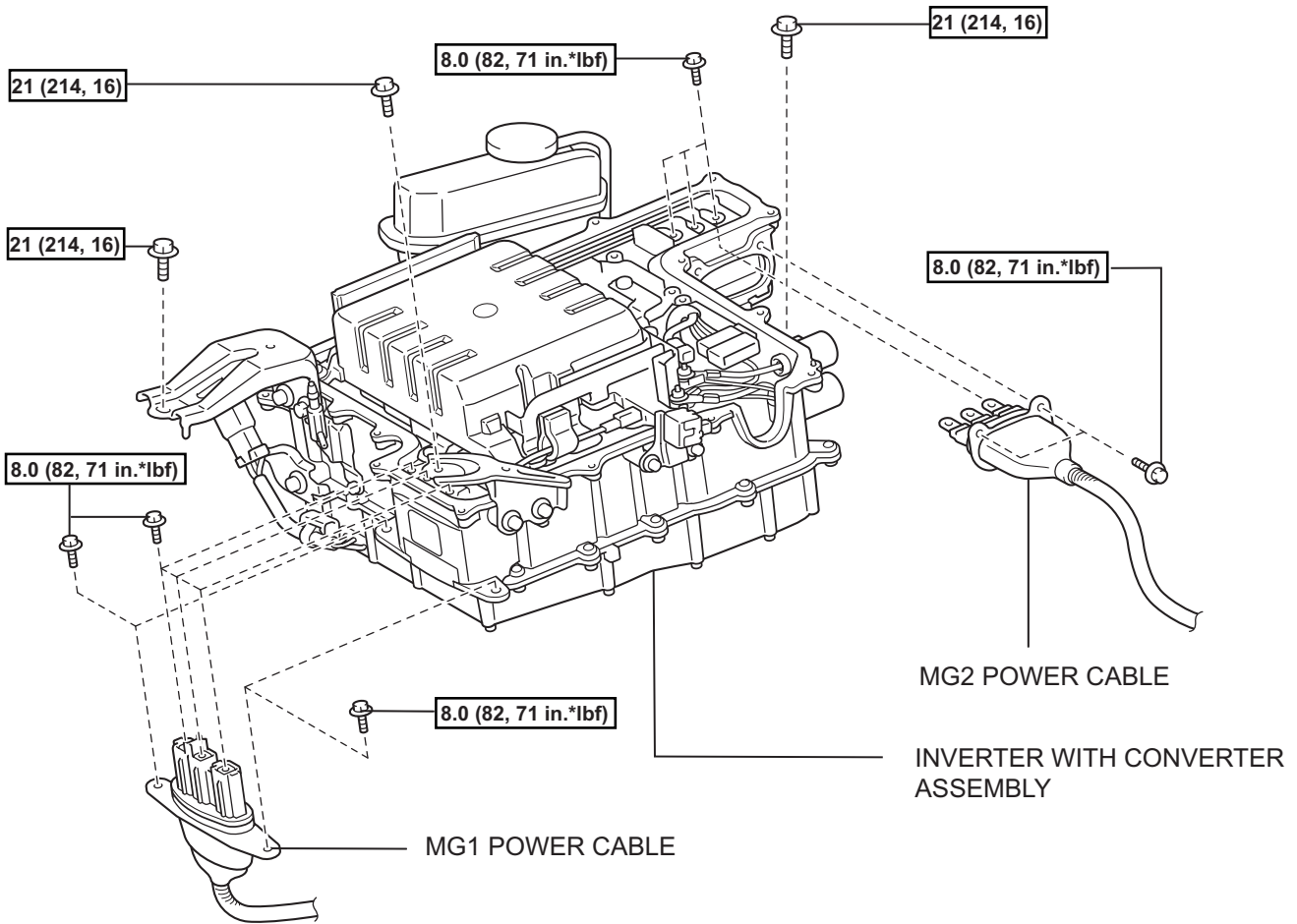

N*m (kgf*cm, ft.*lbf) : Specified torque

HV

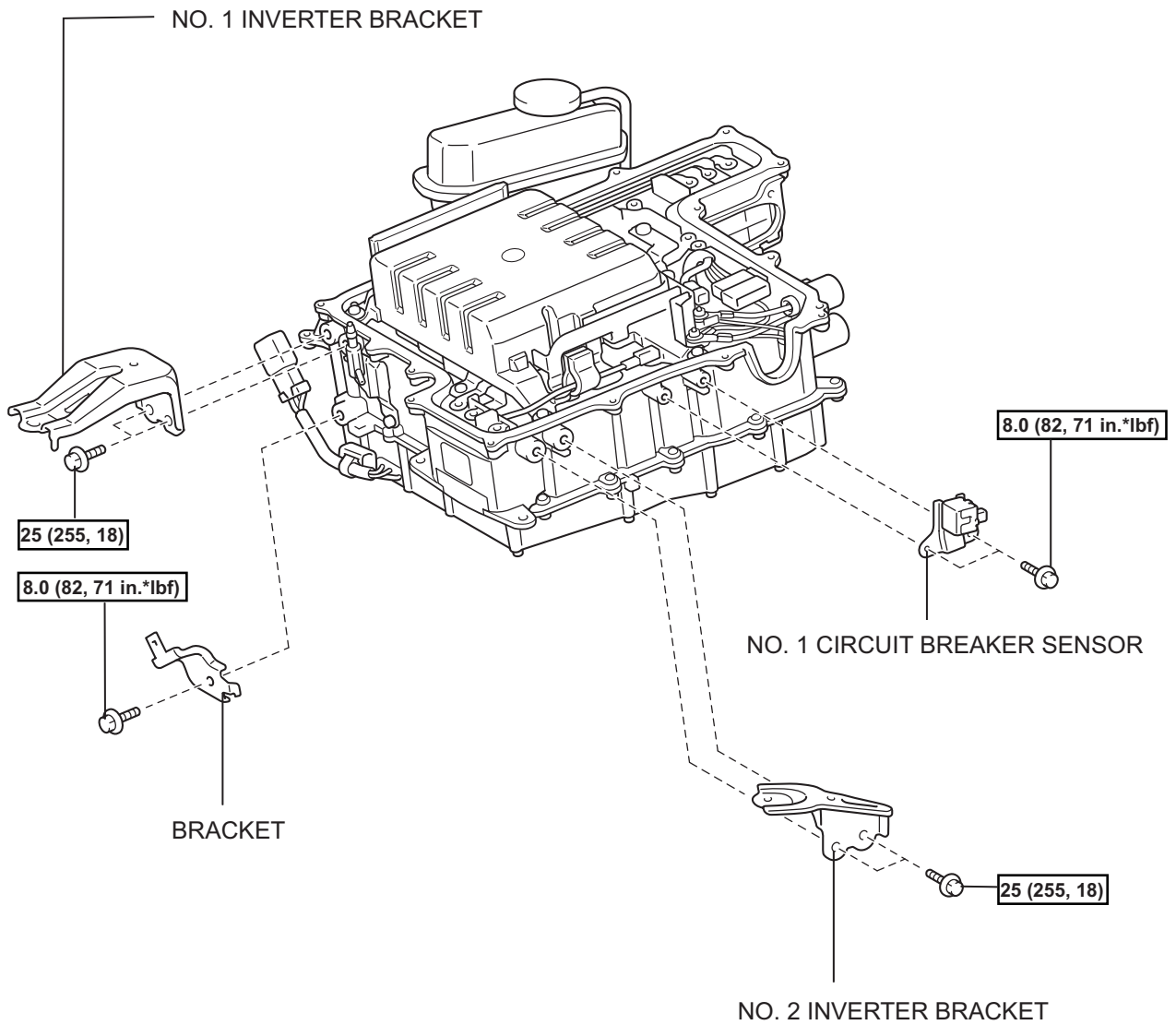

HV

N*m (kgf*cm, ft.*lbf) : Specified torque

ON-VEHICLE INSPECTION

1. INSPECT INVERTER

CAUTION:

Wear insulating gloves.

HINT:

Check DTCs before performing the inspections on the converter and inverter, and perform the appropriate troubleshooting.

- (a) Turn the power switch OFF.
- (b) Remove the service plug grip (see page [HB-153](#)).
- (c) Remove the inverter cover.
 - (1) Using a T30 "torx" socket, remove the screw.
 - (2) Remove the 12 bolts and inverter cover.

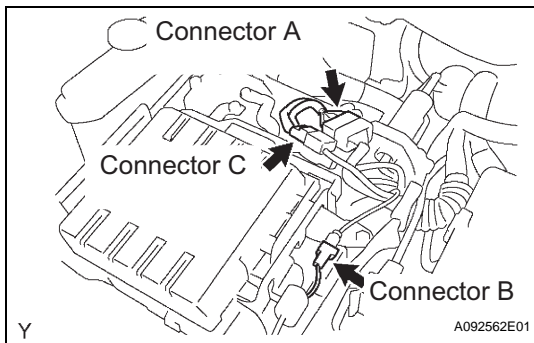
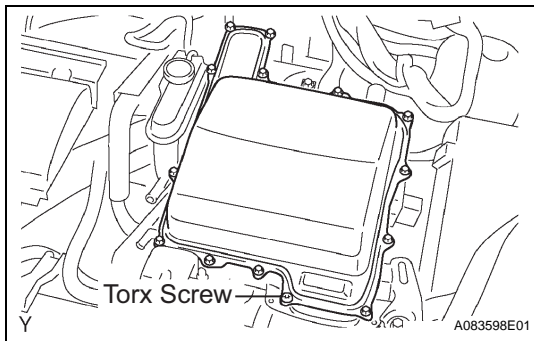

- (d) Disconnect connectors A and B shown in the illustration.
- (e) Turn the power switch ON (IG).
If turning the power switch ON (IG) with the service plug grip removed, the DTC of the interlock switch system will be output.
- (f) Using a voltmeter, measure the voltage. Also, using an ohmmeter, measure the resistance.

NOTICE:

The inspection should be performed on the wire harness side, not on the terminal side.

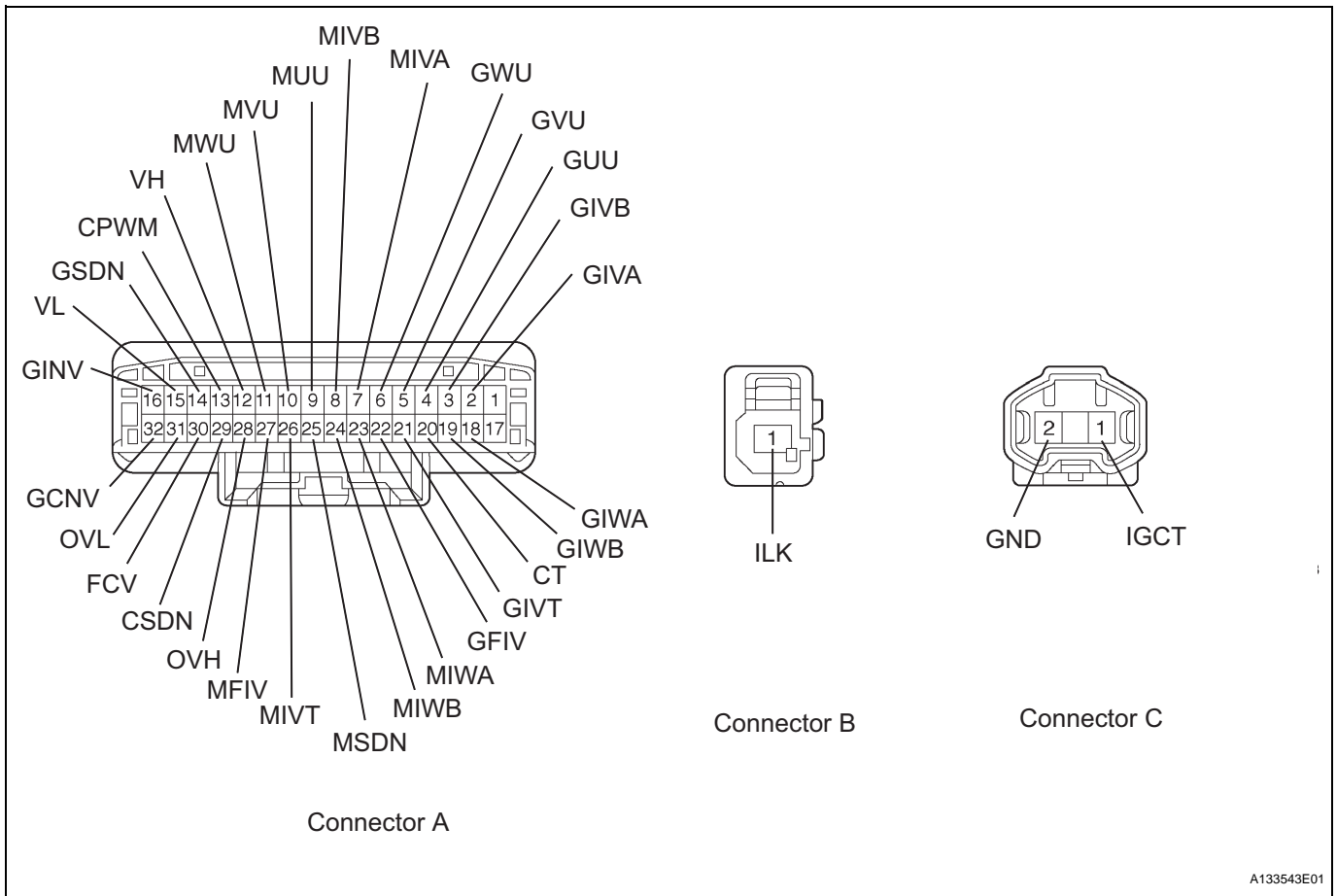

A133543E01

Standard condition

Tester Connection	Measuring Condition	Specified Condition
A-2 (GIVA) - A-16 (GINV)	-	Approximately 0 V
A-3 (GIVB) - A-16 (GINV)	-	Approximately 0 V
A-4 (GUU) - A-16 (GINV)	-	Approximately 14 to 16 V
A-5 (GVU) - A-16 (GINV)	-	Approximately 14 to 16 V
A-6 (GWU) - A-16 (GINV)	-	Approximately 14 to 16 V
A-7 (MIVA) - A-16 (GINV)	-	Approximately 0 V
A-8 (MIVB) - A-16 (GINV)	-	Approximately 0 V
A-9 (MUU) - A-16 (GINV)	-	Approximately 14 to 16 V
A-10 (MVU) - A-16 (GINV)	-	Approximately 14 to 16 V
A-11 (MWU) - A-16 (GINV)	-	Approximately 14 to 16 V
A-12 (VH) - A-16 (GINV)	-	Approximately 0.5 V
A-13 (CPWM) - A-32 (GCNV)	-	Approximately 0 V
A-14 (GSDN) - A-32 (GCNV)	-	Approximately 2 to 4.5 V
A-15 (VL) - A-32 (GCNV)	-	Approximately 0.5 V
A-16 (GINV) - C-2 (GND)	-	Approximately 0 V
A-18 (GIWA) - A-16 (GINV)	-	Approximately 0 V
A-19 (GIWB) - A-16 (GINV)	-	Approximately 0 V
A-20 (CT) - A-16 (GINV)	-	Approximately 0 V
A-21 (GIVT) - A-16 (GINV)	-	Approximately 2 to 4.5 V
A-22 (GFIV) - A-16 (GINV)	-	Approximately 5 to 8 V
A-23 (MIWA) - A-16 (GINV)	-	Approximately 0 V
A-24 (MIWB) - A-16 (GINV)	-	Approximately 0 V
A-25 (MSDN) - A-16 (GINV)	-	Approximately 0 V

HV

Tester Connection	Measuring Condition	Specified Condition
A-26 (MIVT) - A-16 (GINV)	-	Approximately 2 to 4.5 V
A-27 (MFIV) - A-16 (GINV)	-	Approximately 5 to 8 V
A-28 (OVH) - A-16 (GINV)	-	Approximately 5 to 8 V
A-29 (CSDN) - A-32 (GCNV)	-	Approximately 0 V
A-30 (FCV) - A-32 (GCNV)	-	Approximately 13.5 to 16.5 V
A-31 (OVL) - A-32 (GCNV)	-	Approximately 13.5 to 16.5 V
A-32 (GCNV) - C-2 (GND)	-	Approximately 0 V
B-1 (ILK) - Body ground	After installing the probe to the terminal, temporarily install the inverter cover. It does not have to be tightened with the bolts at this point.	Below 1 Ω
C-1 (IGCT) - C-2 (GND)	-	Approximately 8 to 16 V
C-2 (GND) - Body ground	-	Below 1 Ω

If the standards are not met, replace the inverter with converter assembly.

2. INSPECT CONVERTER

CAUTION:

Wear insulating gloves.

HINT:

If the HV system warning, master warning light and charge warning come on at the same time, check the DTCs and perform the appropriate troubleshooting.

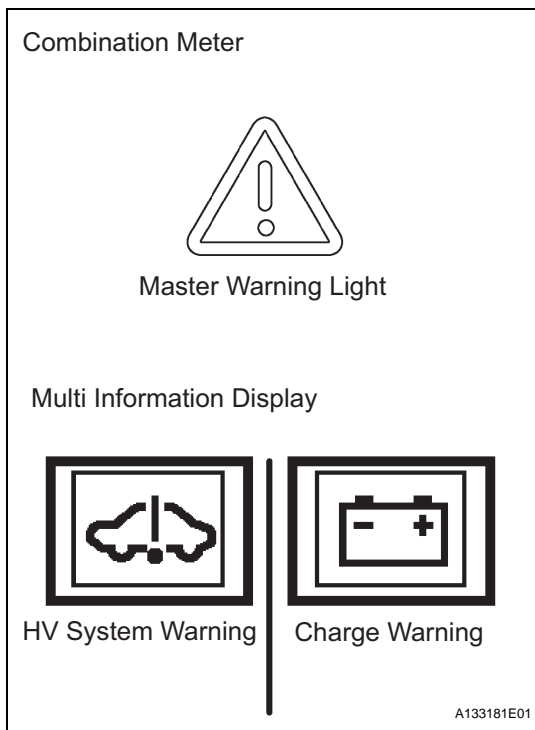

HV

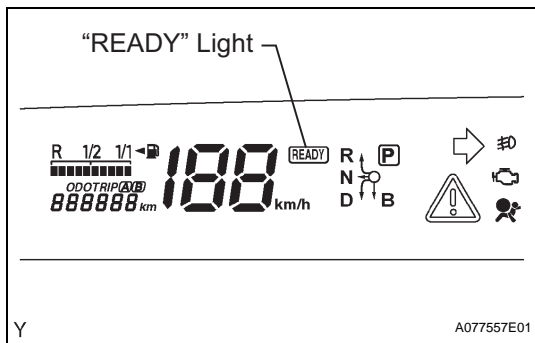

(a) Check the operation.

- (1) Using a voltmeter, measure the voltage of the auxiliary battery terminal when the "READY" light is OFF and ON.

Standard voltage

"READY" Light	Specified Condition
ON	14 V
OFF	12 V

HINT:

When the "READY" light is ON, the converter outputs the voltage. When it is OFF, the auxiliary battery outputs the voltage.

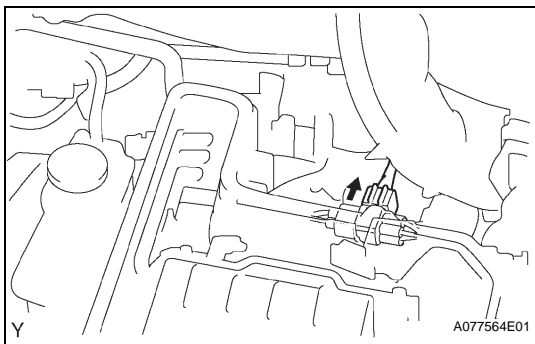
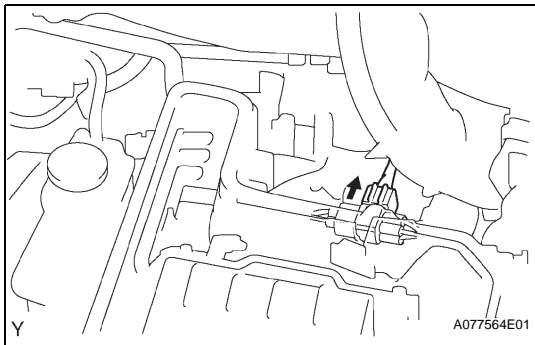
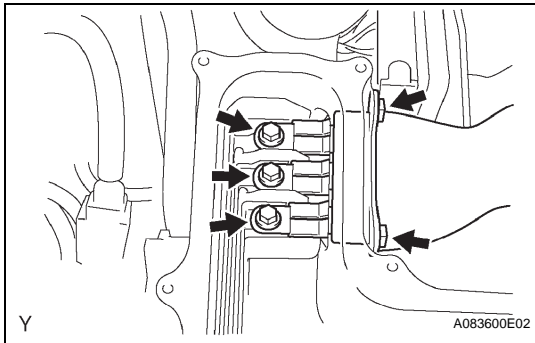
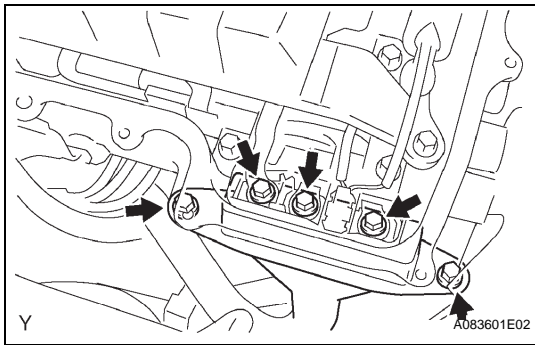

- (b) Inspect the output current.
- (1) Remove the 5 bolts, and disconnect the MG1 power cables from the inverter.

CAUTION:

- Wear insulating gloves.
- Insulate the connector parts with insulating tape.

- (2) Remove the 5 bolts, and disconnect the MG2 power cable.

CAUTION:

- Wear insulating gloves.
- Insulate the connector parts with insulating tape.

- (3) Install a voltmeter and the AC/DC 400 A probe to the locations shown in the illustration.

- (4) Connect the MG1 power cable to the MG1 power cable terminal with the 5 bolts.

Torque: 8.0 N*m (82 kgf*cm, 71 in.*lbf)

CAUTION:

Wear insulating gloves.

- (5) Connect the MG2 power cable to the MG2 power cable terminal with the 3 bolts.

Torque: 8.0 N*m (82 kgf*cm, 71 in.*lbf)

CAUTION:

Wear insulating gloves.

- (6) With the "READY" light ON, operate the 12 V electrical devices one by one, and then measure the output current.

Standard ampere:

Approximately 80 A or less

HINT:

If the output current is 0 A or greater than 80 A, check the input/output signal.

- (c) Check the input/output signal.

- (1) Disconnect the connectors shown in the illustration.
- (2) Using a voltmeter, measure the voltage between the body ground and the terminal of the vehicle side wire harness connector.

Standard condition:

Equal to the auxiliary battery terminal voltage

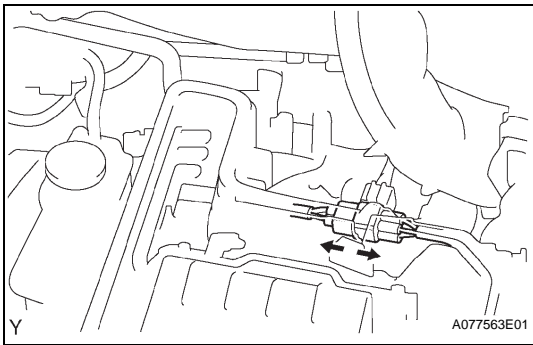

- (3) Disconnect the connectors shown in the illustration.

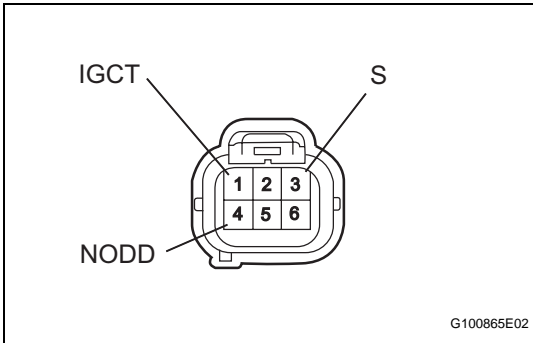

- (4) Turn the power switch ON (IG). Using a voltmeter and ohmmeter, measure the voltage and resistance between the connector terminals on the vehicle harness side.

Standard condition

Tester Connection	Specified Condition
1 (IGCT) - Body ground	8 to 16 V
3 (S) - Body ground	Equal to the auxiliary battery voltage
4 (NODD) - Body ground	120 to 140 kΩ (when power switch is OFF)

If the standards are not met, replace the inverter with converter assembly.

REMOVAL

CAUTION:

- When working on high voltage systems, always wear insulating gloves.
- Keep the removed service plug in your pocket to prevent other technicians from reconnecting it while you are servicing the vehicle.
- After removing the service plug grip, do not touch the high voltage connectors and terminals for 5 minutes.

NOTICE:

After removing the service plug grip, do not operate the power switch as it may damage the hybrid vehicle control ECU.

1. PRECAUTION

CAUTION:

The hybrid system uses high voltage circuits, so improper handling could cause an electric shock or leakage. During service (including installation/removal, inspection and replacement of parts), be sure to follow the procedures (see page [HV-1](#)).

2. REMOVE ENGINE UNDER COVER LH
3. REMOVE ENGINE UNDER COVER RH
4. DRAIN HV COOLANT (See page [HX-58](#))
5. REMOVE REAR NO. 2 FLOOR BOARD (See page [CH-4](#))
6. REMOVE REAR DECK FLOOR BOX (See page [CH-4](#))
7. REMOVE REAR NO. 3 FLOOR BOARD (See page [CH-4](#))
8. DISCONNECT CABLE FROM NEGATIVE BATTERY TERMINAL

CAUTION:

Wait at least 90 seconds after disconnecting the cable from the negative (-) battery terminal to prevent airbag and seat belt pretensioner activation.
9. REMOVE SERVICE PLUG GRIP (See page [HB-154](#))
10. REMOVE FRONT WIPER ARM COVER
11. REMOVE FRONT WIPER ARM RH (See page [WW-13](#))
12. REMOVE FRONT WIPER ARM LH (See page [WW-13](#))
13. REMOVE HOOD TO COWL TOP SEAL (See page [WW-13](#))
14. REMOVE COWL TOP VENTILATOR LOUVER LH (See page [WW-13](#))
15. REMOVE COWL TOP VENTILATOR LOUVER RH (See page [WW-13](#))
16. REMOVE FRONT WIPER LINK AND WIPER MOTOR ASSEMBLY (See page [WW-13](#))

17. REMOVE FRONT COWL TOP PANEL OUTER (See page [FU-12](#))

18. REMOVE RADIATOR SUPPORT OPENING COVER

19. REMOVE INVERTER COVER

- (a) Using a T30 "torx" socket, remove the screw.
- (b) Remove the 12 bolts and inverter cover.

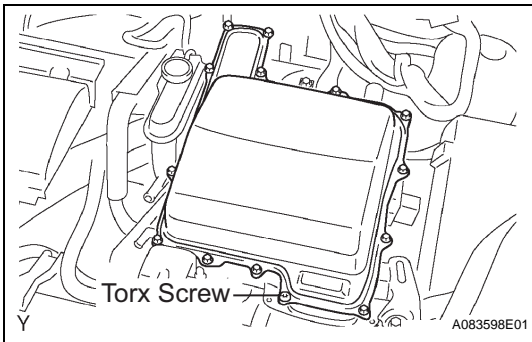

20. VERIFY THAT VOLTAGE OF INVERTER WITH CONVERTER IS 0 V

CAUTION:

Wear insulating gloves.

- (a) Using a voltmeter, measure the voltage of the high voltage DC line.

Standard voltage:

0 V

HINT:

Use a measuring range of DC 400 V or more on the voltmeter.

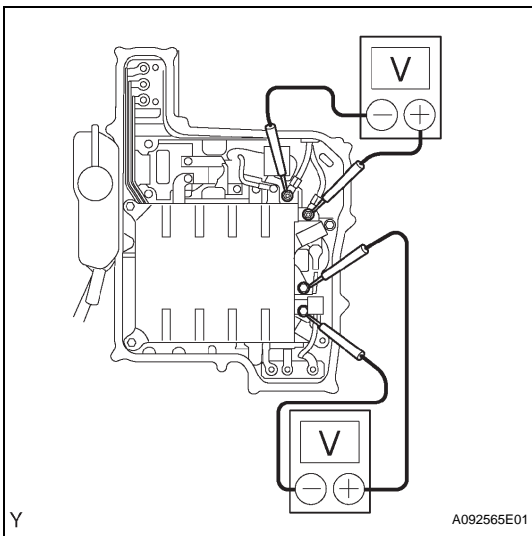

- (b) Using the voltmeter, measure the voltage between the terminals of the three phase connector (U - V, V - W, U - W).

Standard voltage:

0 V

HINT:

Use a measuring range of DC 400 V or more on the voltmeter.

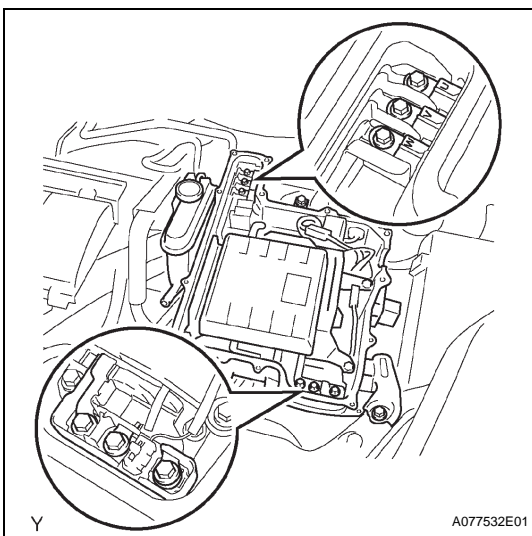

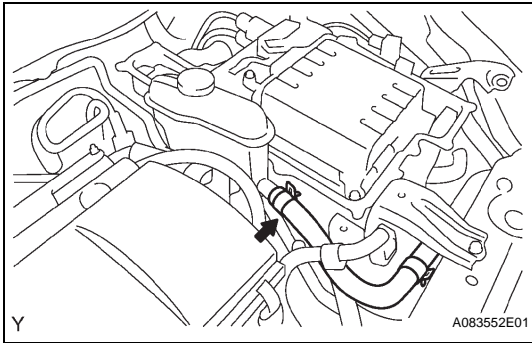

21. DISCONNECT NO. 2 INVERTER COOLING HOSE

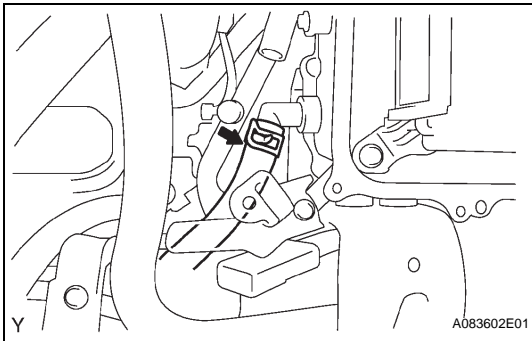

22. DISCONNECT NO. 1 INVERTER COOLING HOSE

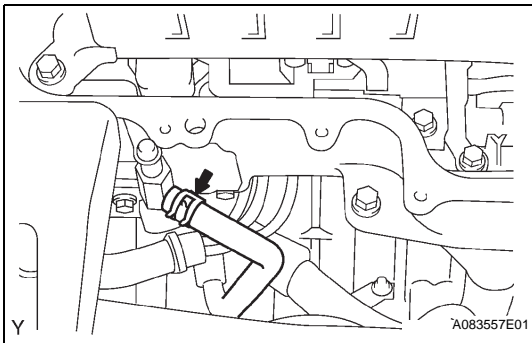

23. DISCONNECT NO. 6 INVERTER COOLING HOSE

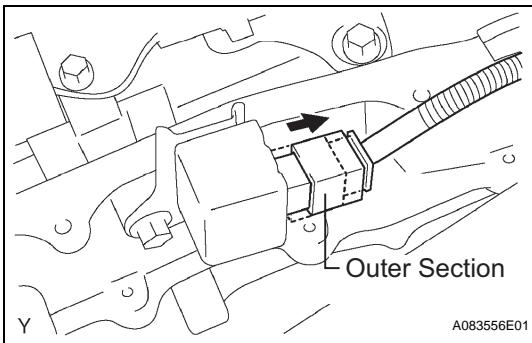

- ### 24. DISCONNECT NO. 1 CIRCUIT BREAKER SENSOR
- (a) Move the outer section to the wire harness side as illustrated, and then disconnect the circuit breaker sensor.

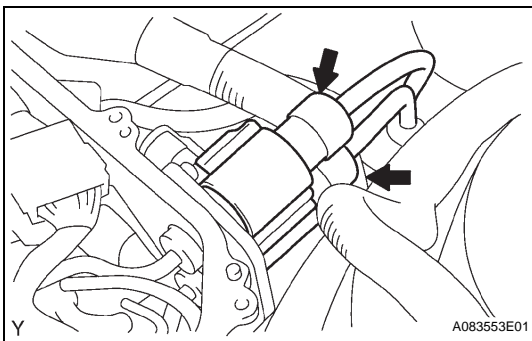

25. DISCONNECT FRAME WIRE

CAUTION:

- Wear insulating gloves.
 - After removing the service plug grip, be sure to wait for at least 5 minutes before performing any work.
 - Insulate the electrode and connector parts with insulating tape.
- (a) Remove the 2 frame wire connectors from the inverter with converter assembly.

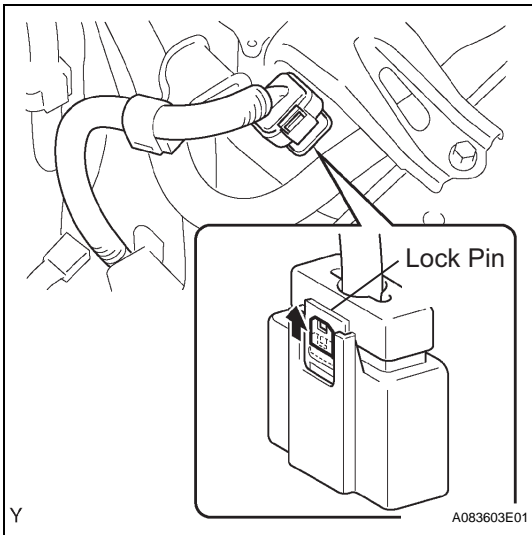

26. REMOVE INVERTER WITH CONVERTER ASSEMBLY

- (a) Using a small screwdriver, lift up the lock pin (green) as illustrated to unlock it.

CAUTION:

Wear insulating gloves.

- (b) Disconnect the connector for the air conditioning inverter.

CAUTION:

Wear insulating gloves.

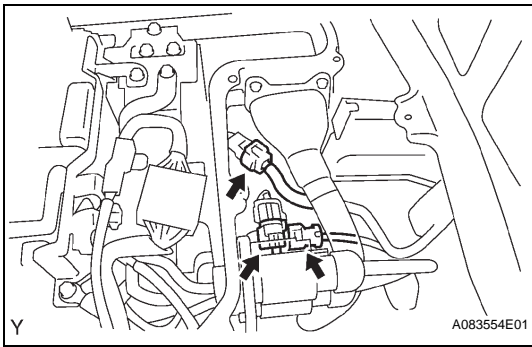

- (c) Disconnect the 3 connectors shown in the illustration.

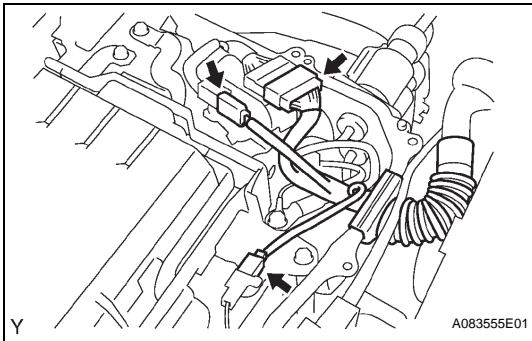

- (d) Disconnect the 3 connectors shown in the illustration and the engine main wire harness.

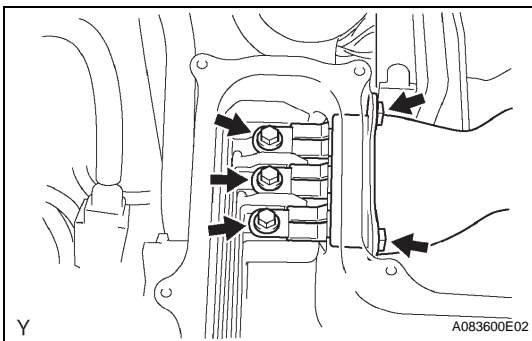

- (e) Remove the 5 bolts, then disconnect the MG2 power cable.

CAUTION:

- **Wear insulating gloves.**
- **Insulate the connector parts with insulating tape.**

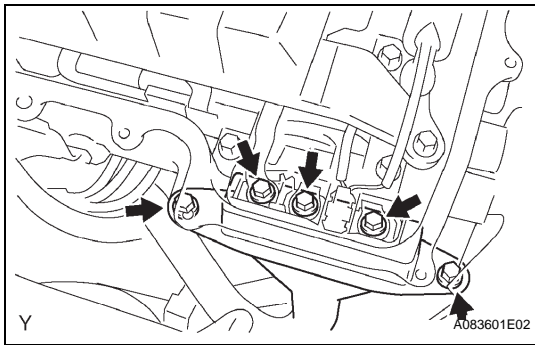

- (f) Remove the 5 bolts, then disconnect the MG1 power cable.

CAUTION:

- **Wear insulating gloves.**
- **Insulate the connector parts with insulating tape.**

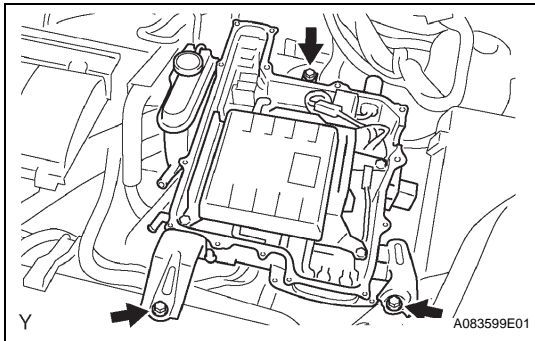

- (g) Remove the 3 bolts and the inverter with converter assembly.

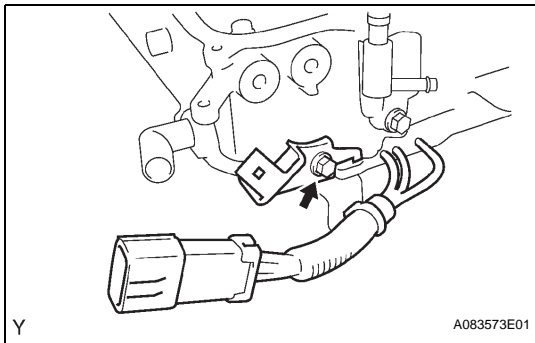

- (h) Disconnect the connector for the air conditioning inverter from the bracket.
 (i) Remove the bolt and connector bracket for the air conditioning inverter.

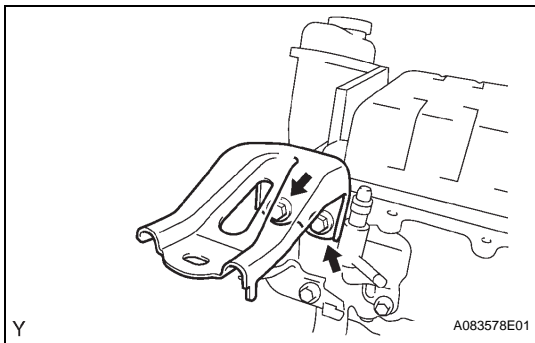

27. REMOVE NO. 1 INVERTER BRACKET

- (a) Remove the 2 bolts and inverter bracket.

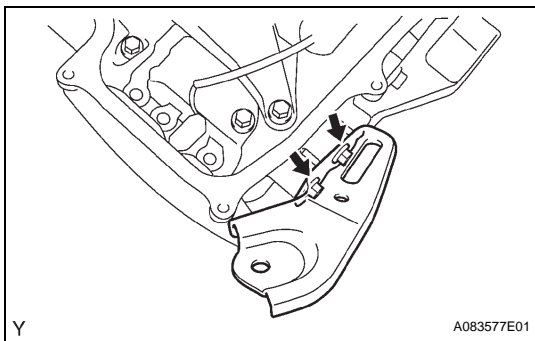

28. REMOVE NO. 2 INVERTER BRACKET

- (a) Remove the 2 bolts and inverter bracket.

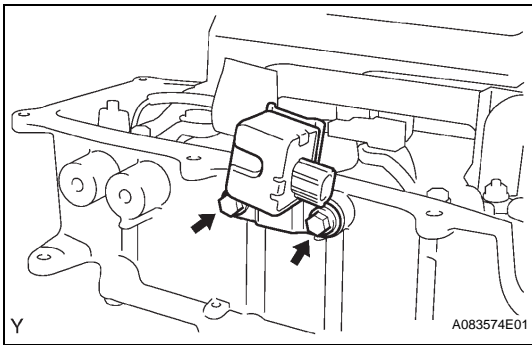
**29. REMOVE NO. 1 CIRCUIT BREAKER SENSOR**

- (a) Remove the 2 bolts and circuit breaker sensor.

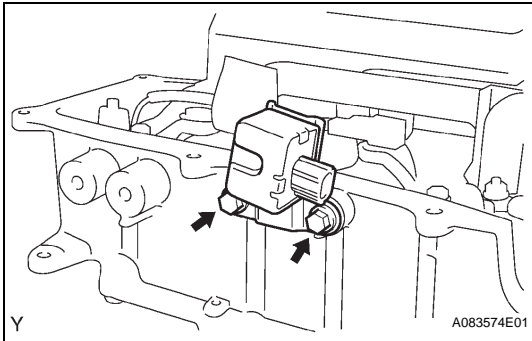
**INSTALLATION****1. INSTALL NO. 1 CIRCUIT BREAKER SENSOR**

- (a) Install the circuit breaker sensor with the 2 bolts.
Torque: 8.0 N*m (82 kgf*cm, 71 in.*lbf)

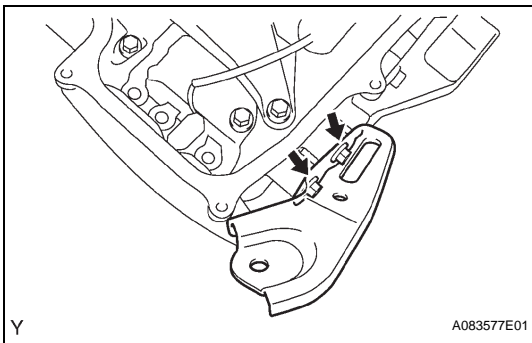
**2. INSTALL NO. 2 INVERTER BRACKET**

- (a) Install the inverter bracket with the 2 bolts.
Torque: 25 N*m (255 kgf*cm, 18 in.*lbf)

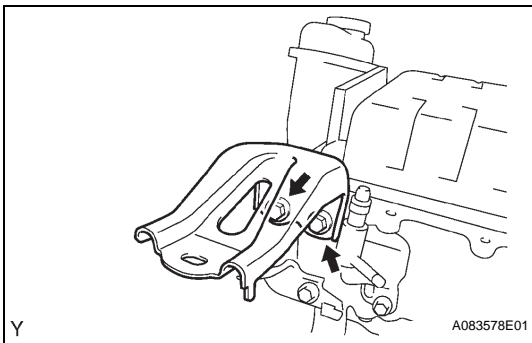
**3. INSTALL NO. 1 INVERTER BRACKET**

- (a) Install the inverter bracket with the 2 bolts.
Torque: 25 N*m (255 kgf*cm, 18 in.*lbf)

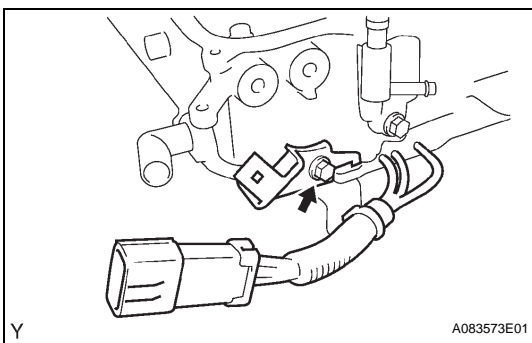
**4. INSTALL INVERTER WITH CONVERTER ASSEMBLY**

- (a) Install the connector bracket for the air conditioning inverter with the bolt.
Torque: 8.0 N*m (82 kgf*cm, 71 in.*lbf)
(b) Install the connector for the air conditioning inverter on the bracket.

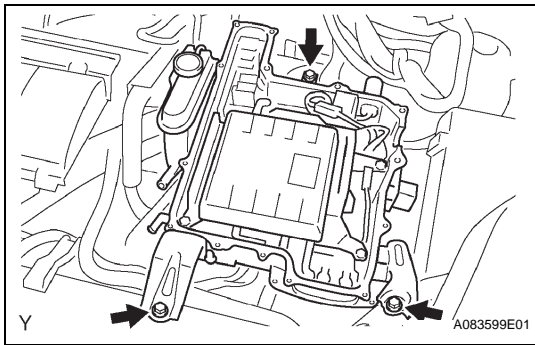

- (c) Install the inverter with converter assembly with the 3 bolts.

Torque: 21 N*m (214 kgf*cm, 16 in.*lbf)

CAUTION:

Wear insulating gloves.

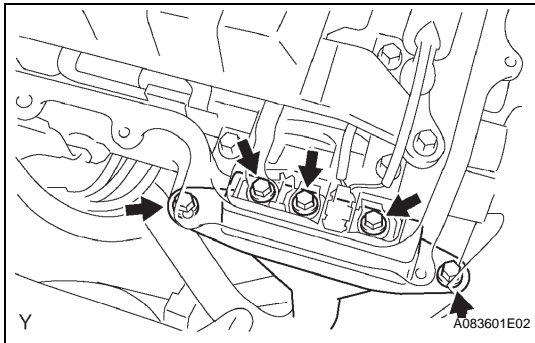

- (d) Install the MG1 power cable to the MG1 power cable terminal with the 5 bolts.

Torque: 8.0 N*m (82 kgf*cm, 71 in.*lbf)

CAUTION:

Wear insulating gloves.

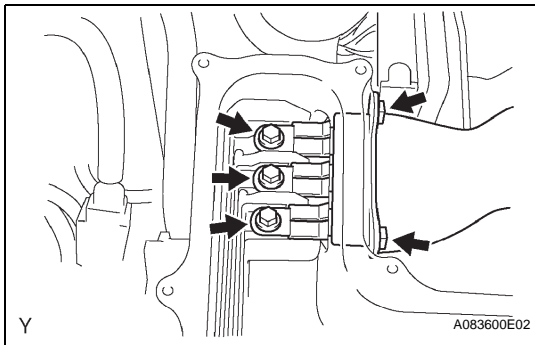

- (e) Install the MG2 power cable to the MG2 power cable terminal with the 3 bolts.

Torque: 8.0 N*m (82 kgf*cm, 71 in.*lbf)

CAUTION:

Wear insulating gloves.

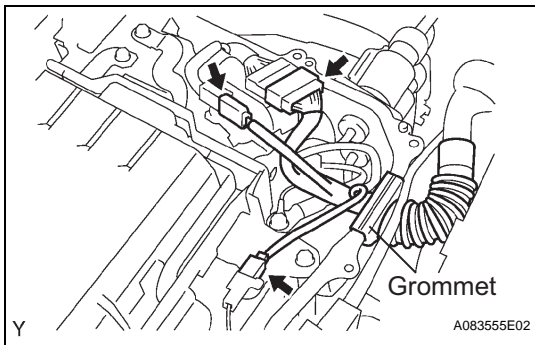

- (f) Connect the 3 connectors shown in the illustration.

CAUTION:

Wear insulating gloves.

- (g) Insert the grommet of the engine main wire harness into the U-shaped groove of the inverter case.

CAUTION:

Wear insulating gloves.

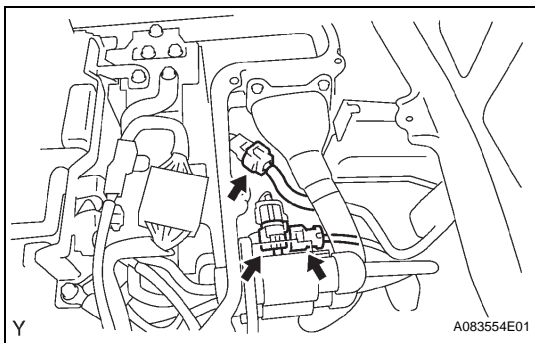

- (h) Connect the 3 connectors shown in the illustration.

CAUTION:

Wear insulating gloves.

- (i) Connect the connector for the air conditioning inverter, then lock the connector with the lock pin.

CAUTION:

Wear insulating gloves.

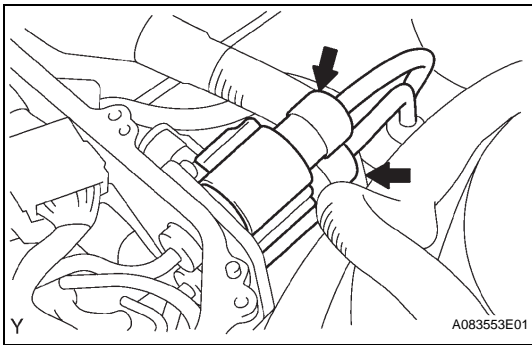

5. CONNECT FRAME WIRE

- (a) Connect the 2 frame wire connectors to the inverter with converter assembly.

CAUTION:

Wear insulating gloves.

6. CONNECT NO. 1 CIRCUIT BREAKER SENSOR

CAUTION:

Wear insulating gloves.

7. CONNECT NO. 6 INVERTER COOLING HOSE

8. CONNECT NO. 1 INVERTER COOLING HOSE

9. CONNECT NO. 2 INVERTER COOLING HOSE

10. INSTALL INVERTER COVER

- (a) Temporarily fasten the inverter cover with the 12 bolts and "torx" screw.

- (b) Tighten the 12 bolts.

Torque: 11 N*m (112 kgf*cm, 8.1 in.*lbf)

- (c) Using a T30 "torx" socket, tighten the "torx" screw.

Torque: 11 N*m (112 kgf*cm, 8.1 in.*lbf)

11. INSTALL RADIATOR SUPPORT OPENING COVER

12. INSTALL FRONT COWL TOP PANEL OUTER (See page [FU-19](#))

13. INSTALL WINDSHIELD WIPER LINK AND WIPER MOTOR ASSEMBLY (See page [WW-16](#))

14. INSTALL COWL TOP VENTILATOR LOUVER RH

15. INSTALL COWL TOP VENTILATOR LOUVER LH

16. INSTALL HOOD TO COWL TOP SEAL

17. INSTALL FRONT WIPER ARM LH (See page [WW-16](#))

18. INSTALL FRONT WIPER ARM RH (See page [WW-16](#))

19. INSTALL WINDSHIELD WIPER ARM COVER

20. INSTALL SERVICE PLUG GRIP (See page [HB-154](#))

21. CONNECT CABLE TO NEGATIVE BATTERY TERMINAL (See page [CH-7](#))

22. INSTALL REAR NO. 3 FLOOR BOARD (See page [CH-8](#))

23. INSTALL REAR DECK FLOOR BOX (See page [CH-8](#))

24. INSTALL REAR NO. 2 FLOOR BOARD (See page [CH-8](#))

25. ADD HV COOLANT (See page [HX-58](#))

26. CHECK FOR ENGINE COOLANT LEAKAGE (See page [CO-2](#))

27. INSTALL ENGINE UNDER COVER RH

28. INSTALL ENGINE UNDER COVER LH

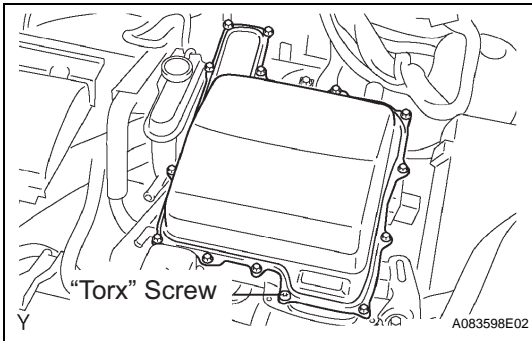

29. PERFORM INITIALIZATION

- (a) Perform initialization (see page [IN-32](#)).

NOTICE:

Certain systems need to be initialized after disconnecting and reconnecting the cable from the negative (-) battery terminal.

HYBRID VEHICLE CONTROL ECU

COMPONENTS

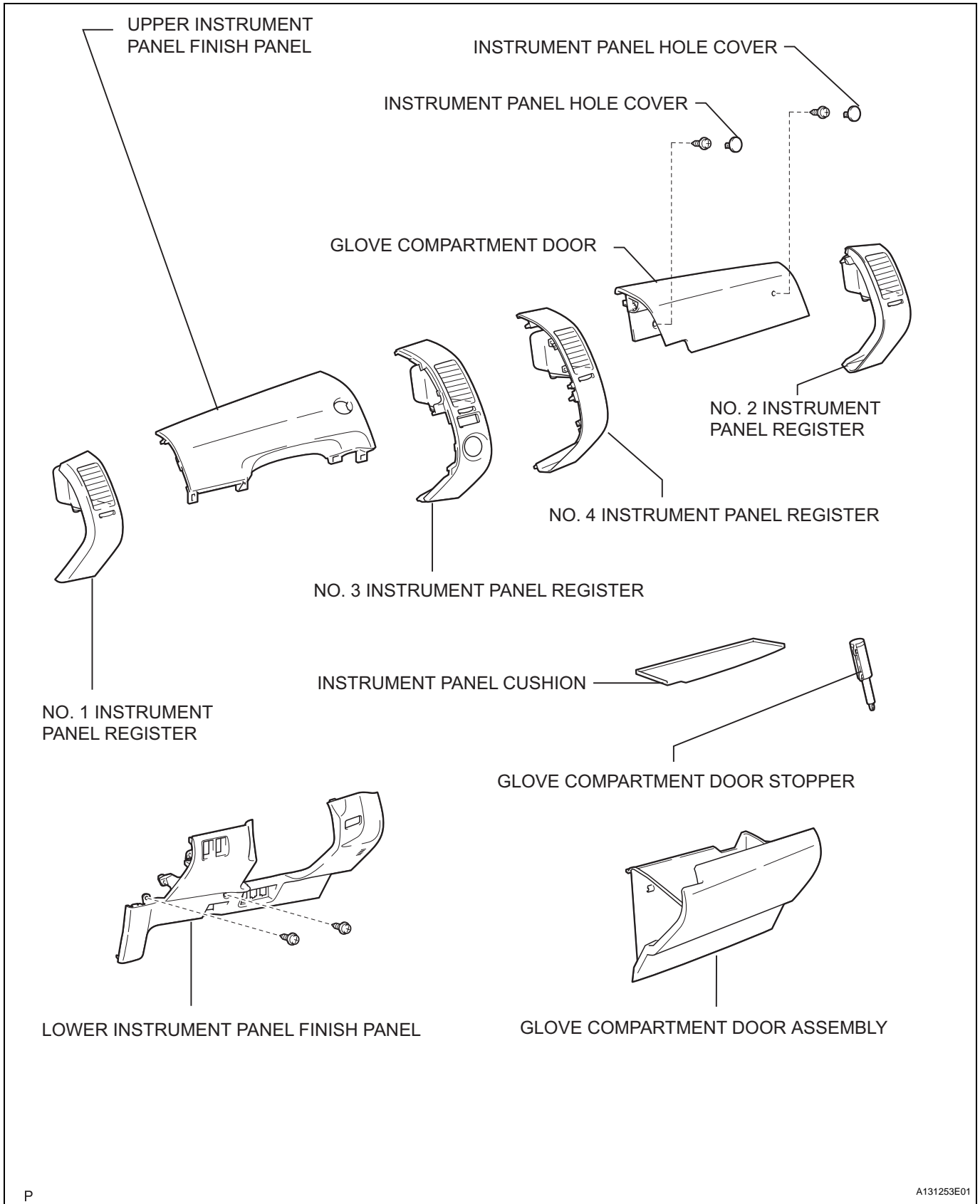

HV

NO. 1 INSTRUMENT PANEL SPEAKER
PANEL (w/ JBL Sound System)

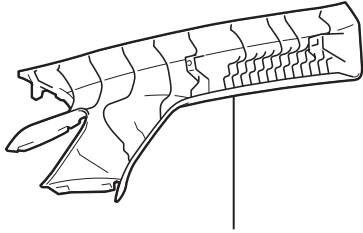

FRONT PILLAR GARNISH LH

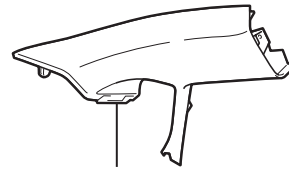

FRONT PILLAR GARNISH RH



FRONT PILLAR GARNISH CORNER PIECE RH



FRONT PILLAR GARNISH CORNER PIECE LH

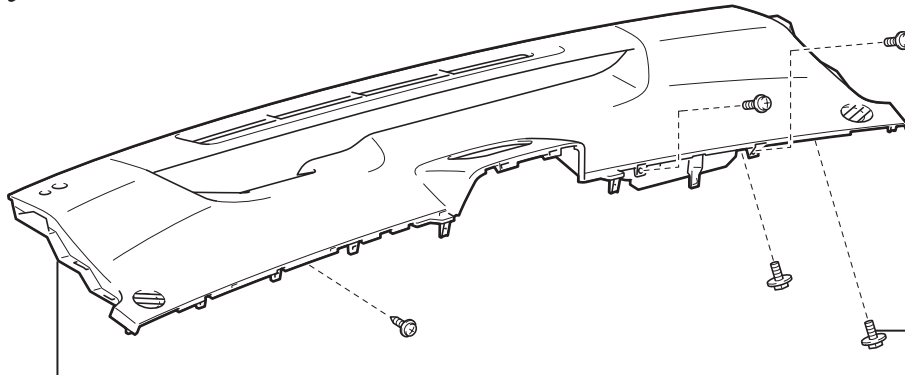

INSTRUMENT PANEL SUB-ASSEMBLY

20 (204, 15)

HV



CLOCK ASSEMBLY

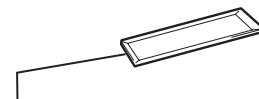

INSTRUMENT CLUSTER FINISH PANEL END

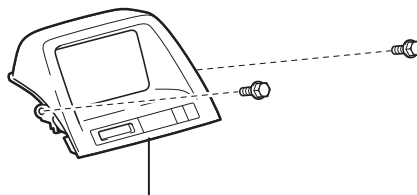

MULTI-DISPLAY ASSEMBLY

N*m (kgf*cm, ft.*lbf) : Specified torque

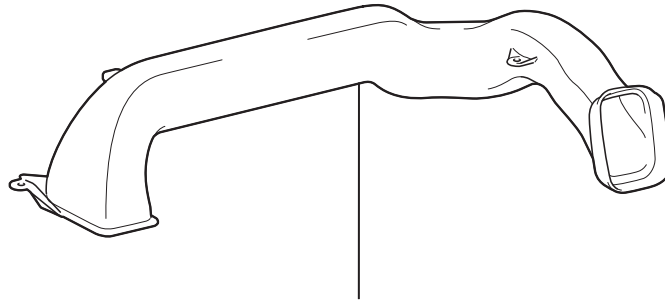

NO. 3 HEATER TO REGISTER DUCT

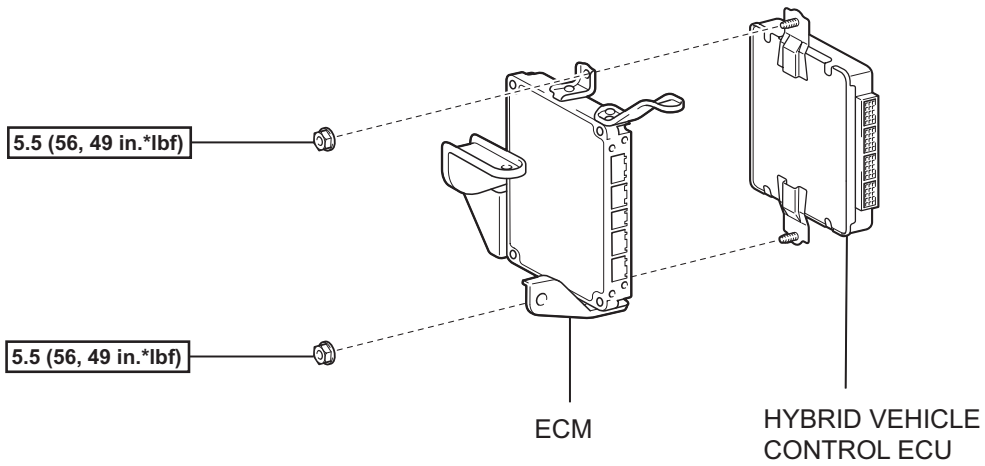

5.5 (56, 49 in.*lbf) : Specified torque

HV

REMOVAL

1. REMOVE REAR NO. 2 FLOOR BOARD (See page [CH-4](#))
2. REMOVE REAR DECK FLOOR BOX (See page [CH-4](#))
3. REMOVE REAR NO. 3 FLOOR BOARD (See page [CH-4](#))
4. DISCONNECT CABLE FROM NEGATIVE BATTERY TERMINAL
CAUTION:
Wait at least 90 seconds after disconnecting the cable from the negative (-) battery terminal to prevent airbag and seat belt pretensioner activation.
5. REMOVE NO. 1 INSTRUMENT PANEL REGISTER (See page [IP-5](#))
6. REMOVE LOWER INSTRUMENT PANEL FINISH PANEL (See page [IP-6](#))
7. REMOVE UPPER INSTRUMENT PANEL FINISH PANEL (See page [IP-6](#))
8. REMOVE NO. 3 INSTRUMENT PANEL REGISTER (See page [IP-6](#))
9. REMOVE NO. 4 INSTRUMENT PANEL REGISTER (See page [IP-6](#))
10. REMOVE NO. 2 INSTRUMENT PANEL REGISTER (See page [IP-7](#))
11. REMOVE MULTI-DISPLAY ASSEMBLY (See page [NS-172](#))
12. REMOVE GLOVE COMPARTMENT DOOR STOPPER (See page [IP-7](#))
13. REMOVE GLOVE COMPARTMENT DOOR ASSEMBLY (See page [IP-7](#))
14. REMOVE GLOVE COMPARTMENT DOOR (See page [IP-7](#))
15. REMOVE NO. 1 INSTRUMENT PANEL SPEAKER PANEL
16. REMOVE FRONT PILLAR GARNISH CORNER PIECE RH
17. REMOVE FRONT PILLAR GARNISH CORNER PIECE LH
18. REMOVE FRONT PILLAR GARNISH RH
19. REMOVE FRONT PILLAR GARNISH LH
20. DISCONNECT AIRBAG CONNECTOR
21. REMOVE INSTRUMENT PANEL SUB-ASSEMBLY (See page [IP-8](#))

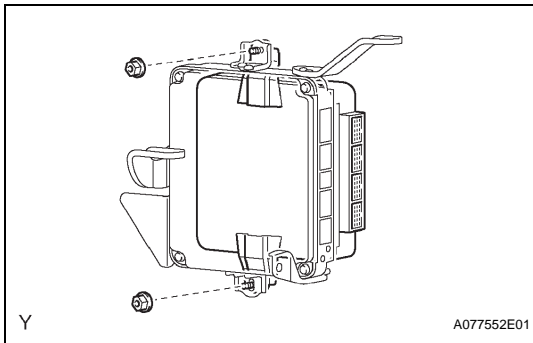
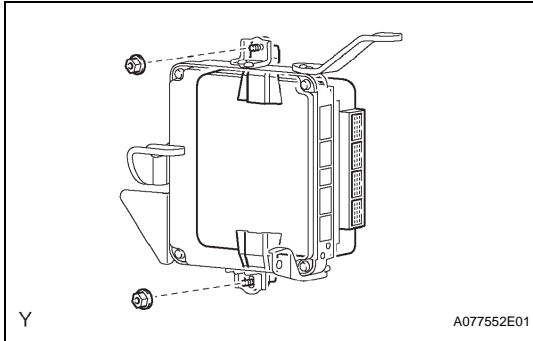

22. REMOVE NO. 3 HEATER TO REGISTER DUCT (See page [AC-147](#))
23. REMOVE ECM (See page [ES-469](#))
24. REMOVE HYBRID VEHICLE CONTROL ECU
 - (a) Remove the 2 nuts and hybrid vehicle control ECU.

INSTALLATION

1. INSTALL HYBRID VEHICLE CONTROL ECU
 - (a) Install the hybrid vehicle control ECU with the 2 nuts.
Torque: 5.5 N*m (56 kgf*cm, 49 in.*lbf)
2. INSTALL ECM (See page [ES-470](#))
3. INSTALL NO. 3 HEATER TO REGISTER DUCT (See page [AC-159](#))
4. INSTALL INSTRUMENT PANEL SUB-ASSEMBLY (See page [IP-11](#))
5. CONNECT AIRBAG CONNECTOR
6. INSTALL FRONT PILLAR GARNISH RH
7. INSTALL FRONT PILLAR GARNISH LH
8. INSTALL FRONT PILLAR GARNISH CORNER PIECE RH
9. INSTALL FRONT PILLAR GARNISH CORNER PIECE LH
10. INSTALL NO. 1 INSTRUMENT PANEL SPEAKER PANEL
11. INSTALL GLOVE COMPARTMENT DOOR (See page [IP-12](#))
12. INSTALL GLOVE COMPARTMENT DOOR ASSEMBLY (See page [IP-12](#))
13. INSTALL GLOVE COMPARTMENT DOOR STOPPER
14. INSTALL MULTI-DISPLAY ASSEMBLY
15. INSTALL NO. 2 INSTRUMENT PANEL REGISTER (See page [IP-12](#))
16. INSTALL NO. 4 INSTRUMENT PANEL REGISTER (See page [IP-12](#))
17. INSTALL NO. 3 INSTRUMENT PANEL REGISTER (See page [IP-13](#))

18. INSTALL UPPER INSTRUMENT PANEL FINISH PANEL (See page [IP-13](#))
19. INSTALL LOWER INSTRUMENT PANEL FINISH PANEL (See page [IP-13](#))
20. INSTALL NO. 1 INSTRUMENT PANEL REGISTER (See page [IP-13](#))
21. CONNECT CABLE TO NEGATIVE BATTERY TERMINAL (See page [CH-7](#))
22. CHECK SRS WARNING LIGHT
23. INSTALL REAR NO. 3 FLOOR BOARD (See page [CH-8](#))
24. INSTALL REAR DECK FLOOR BOX (See page [CH-8](#))
25. INSTALL REAR NO. 2 FLOOR BOARD (See page [CH-8](#))
26. PERFORM INITIALIZATION
 - (a) Perform initialization (see page [IN-32](#)).
NOTICE:
Certain systems need to be initialized after disconnecting and reconnecting the cable from the negative (-) battery terminal.

WATER PUMP WITH MOTOR

COMPONENTS

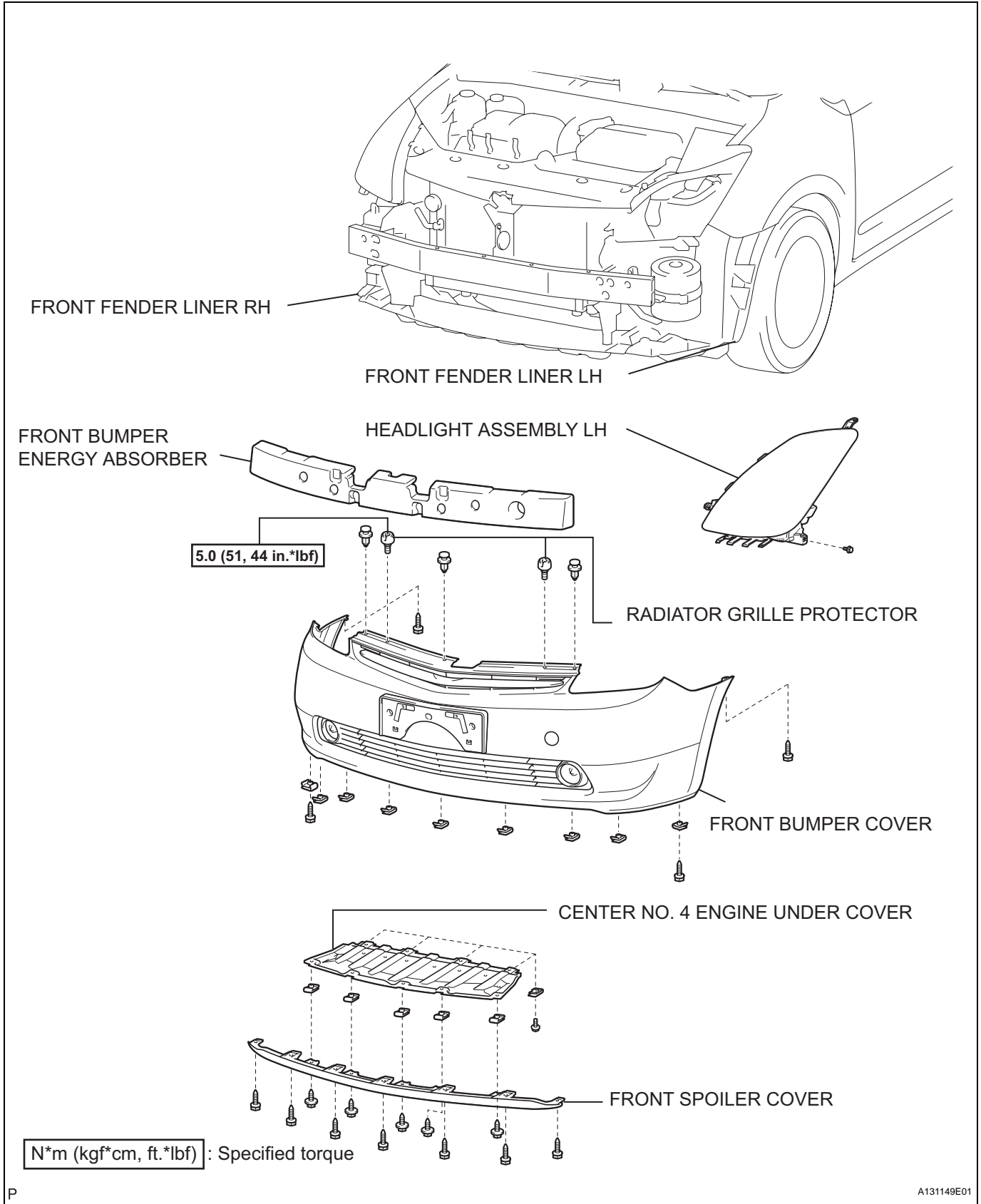

HV

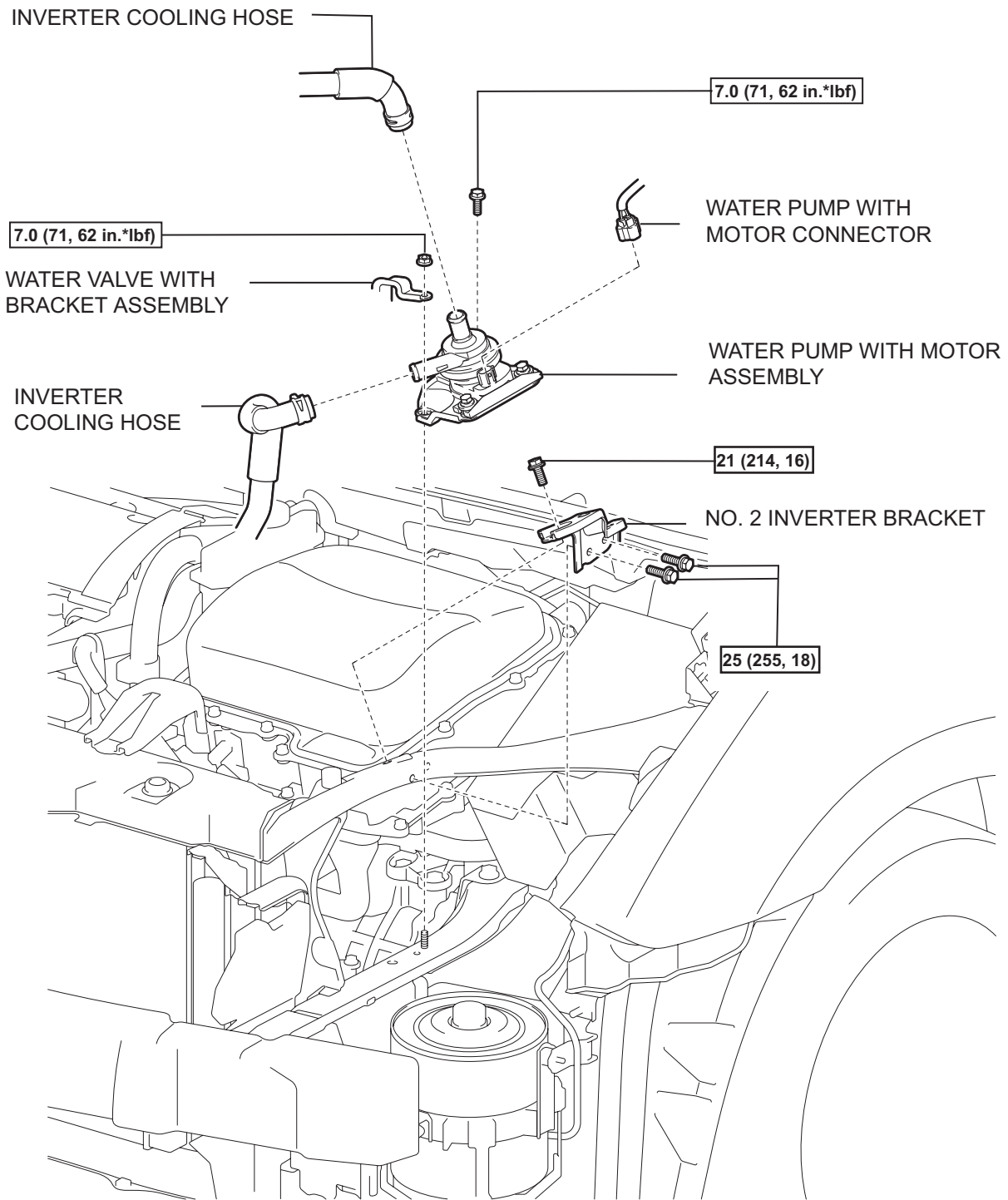

HV

N*m (kgf*cm, ft.*lbf) : Specified torque

REMOVAL

1. REMOVE REAR NO. 2 FLOOR BOARD (See page [CH-4](#))
2. REMOVE REAR DECK FLOOR BOX (See page [CH-4](#))
3. REMOVE REAR NO. 3 FLOOR BOARD (See page [CH-4](#))
4. DISCONNECT CABLE FROM NEGATIVE BATTERY TERMINAL
CAUTION:
 Wait at least 90 seconds after disconnecting the cable from the negative (-) battery terminal to prevent airbag and seat belt pretensioner activation.
5. DISCONNECT FRONT FENDER LINER LH (See page [ET-3](#))
6. DISCONNECT FRONT FENDER LINER RH (See page [ET-3](#))
7. REMOVE CENTER NO. 4 ENGINE UNDER COVER (See page [ET-3](#))
8. REMOVE FRONT SPOILER COVER (See page [ET-3](#))
9. REMOVE FRONT BUMPER COVER (See page [ET-4](#))
10. REMOVE FRONT BUMPER ENERGY ABSORBER
11. REMOVE HEADLIGHT ASSEMBLY LH
 - (a) Remove the headlight LH from the vehicle (see page [LI-77](#)).
12. DRAIN HV COOLANT (See page [HX-58](#))
13. DISCONNECT WATER VALVE WITH BRACKET ASSEMBLY
 - (a) Remove the bolt and nut, then disconnect the water valve.

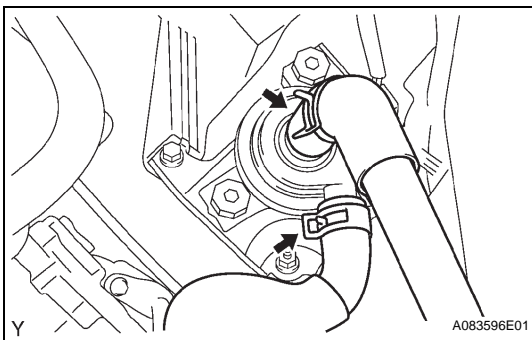
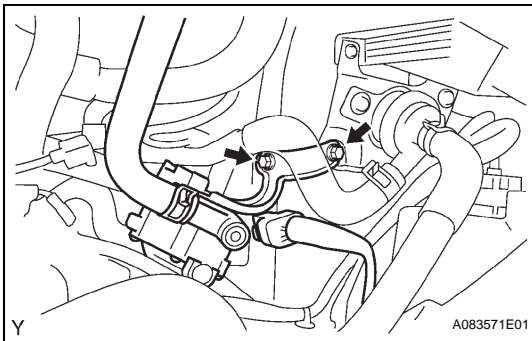

14. REMOVE WATER PUMP WITH MOTOR ASSEMBLY
 - (a) Disconnect the 2 inverter cooling hoses shown in the illustration.

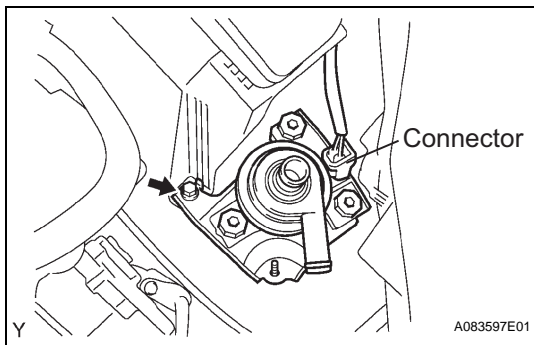

- (b) Remove the bolt, then disconnect the water pump with motor assembly from the vehicle.
- (c) Disconnect the connector and remove the water pump with motor assembly.

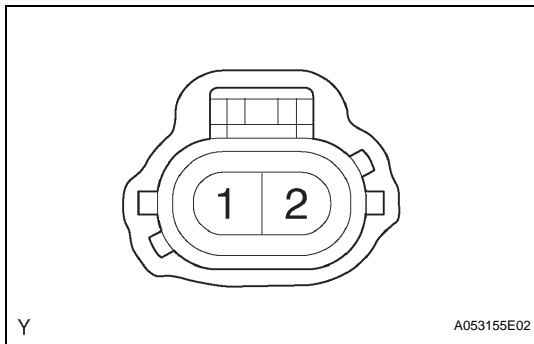

INSPECTION

1. INSPECT WATER PUMP WITH MOTOR

- (a) Check the operation.
 - (1) Connect the battery positive terminal to terminal 1 and the battery negative terminal to terminal 2.

Specified condition:

Pump motor operates properly

NOTICE:

- **Do not connect the positive and negative terminals of the battery to the wrong water pump terminals.**
- **Complete the check within 10 seconds of the connection.**

If the pump motor does not operate properly, replace the water pump with motor assembly.

INSTALLATION

1. INSTALL WATER PUMP WITH MOTOR ASSEMBLY

- (a) Connect the connector.
- (b) Install the water pump with motor assembly with the bolt.

Torque: 7.0 N*m (71 kgf*cm, 62 in.*lbf)

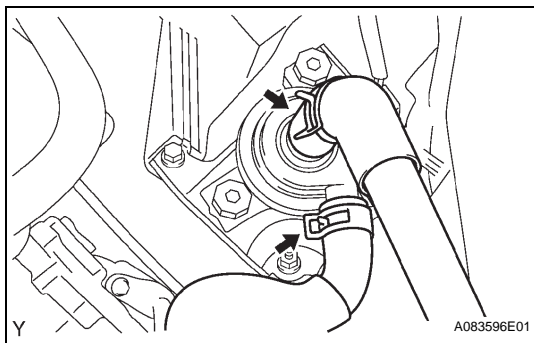
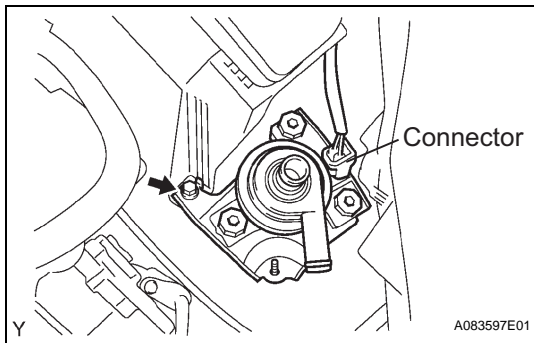

- (c) Connect the 2 inverter cooling hoses.

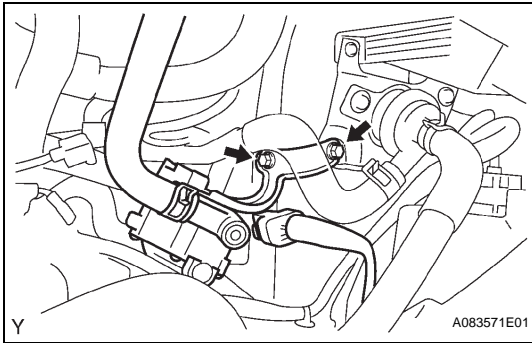

2. **INSTALL WATER VALVE WITH BRACKET ASSEMBLY**
 - (a) Install the water valve with the bolt and nut.
Torque: 7.0 N*m (71 kgf*cm, 62 in.*lbf)
3. **INSTALL HEADLIGHT ASSEMBLY LH**
 - (a) Install the headlight LH to the vehicle (see page [LI-82](#)).
4. **INSTALL FRONT BUMPER ENERGY ABSORBER**
5. **INSTALL FRONT BUMPER COVER (See page [ET-6](#))**
6. **INSTALL FRONT SPOILER COVER (See page [ET-7](#))**
7. **INSTALL CENTER NO. 4 ENGINE UNDER COVER (See page [ET-7](#))**
8. **INSTALL FRONT FENDER LINER LH (See page [ET-7](#))**
9. **INSTALL FRONT FENDER LINER RH (See page [ET-7](#))**
10. **ADD HV COOLANT (See page [HX-58](#))**
11. **CHECK ENGINE COOLANT LEAKAGE (See page [CO-2](#))**
12. **CONNECT CABLE TO NEGATIVE BATTERY TERMINAL (See page [CH-7](#))**
13. **INSTALL REAR NO. 3 FLOOR BOARD (See page [CH-8](#))**
14. **INSTALL REAR DECK FLOOR BOX (See page [CH-8](#))**
15. **INSTALL REAR NO. 2 FLOOR BOARD (See page [CH-8](#))**
16. **PERFORM INITIALIZATION**
 - (a) Perform initialization (see page [IN-32](#)).

NOTICE:
Certain systems need to be initialized after disconnecting and reconnecting the cable from the negative (-) battery terminal.

FRAME WIRE COMPONENTS

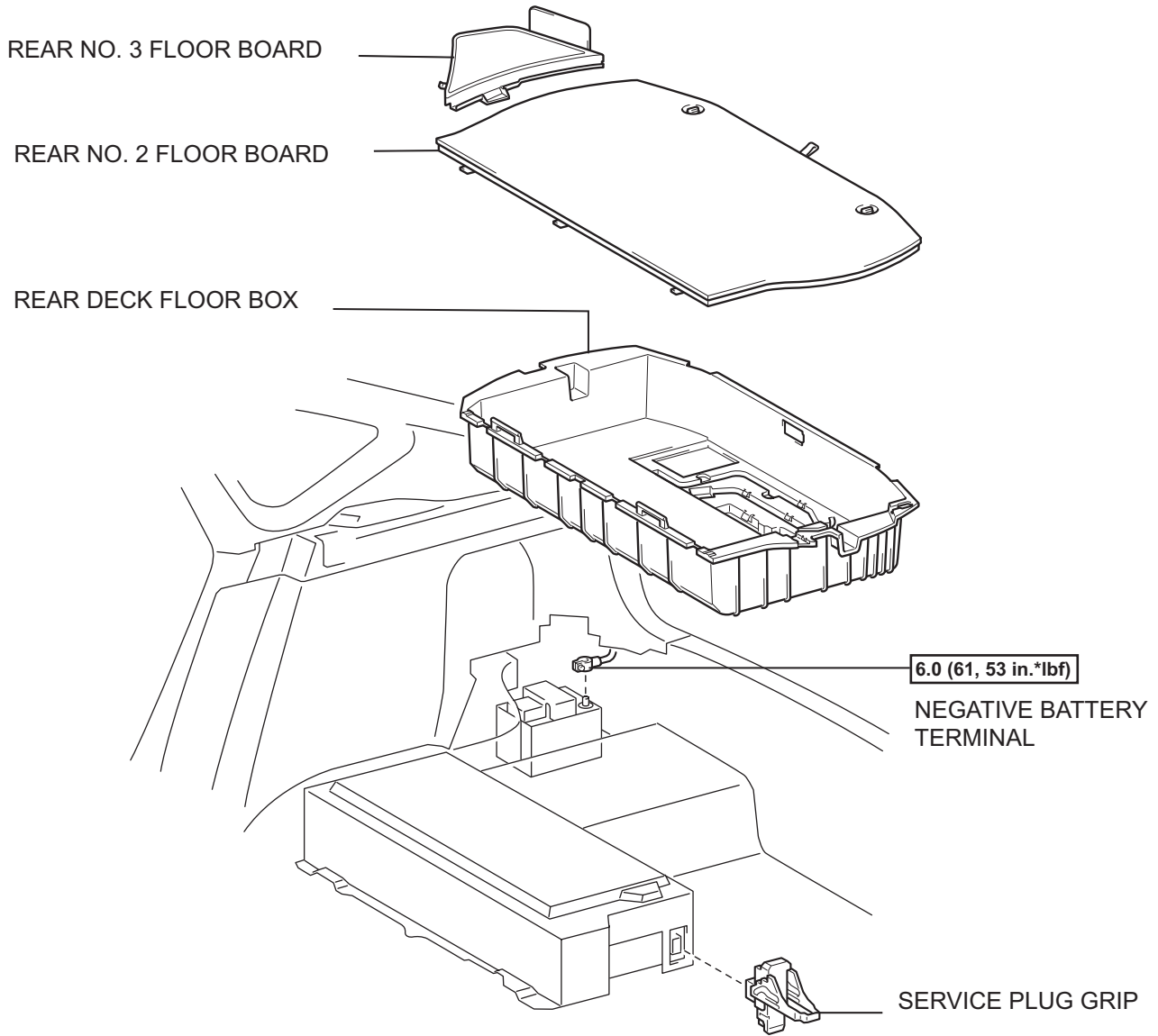

N*m (kgf*cm, ft.*lbf) : Specified torque

HV

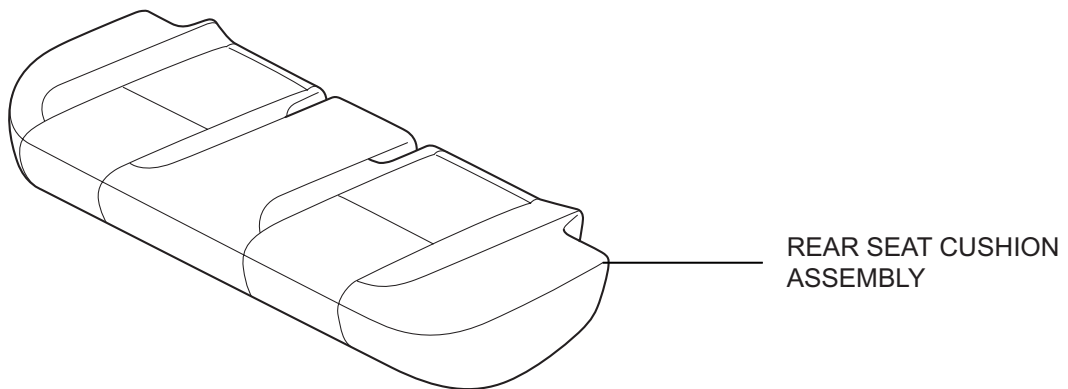
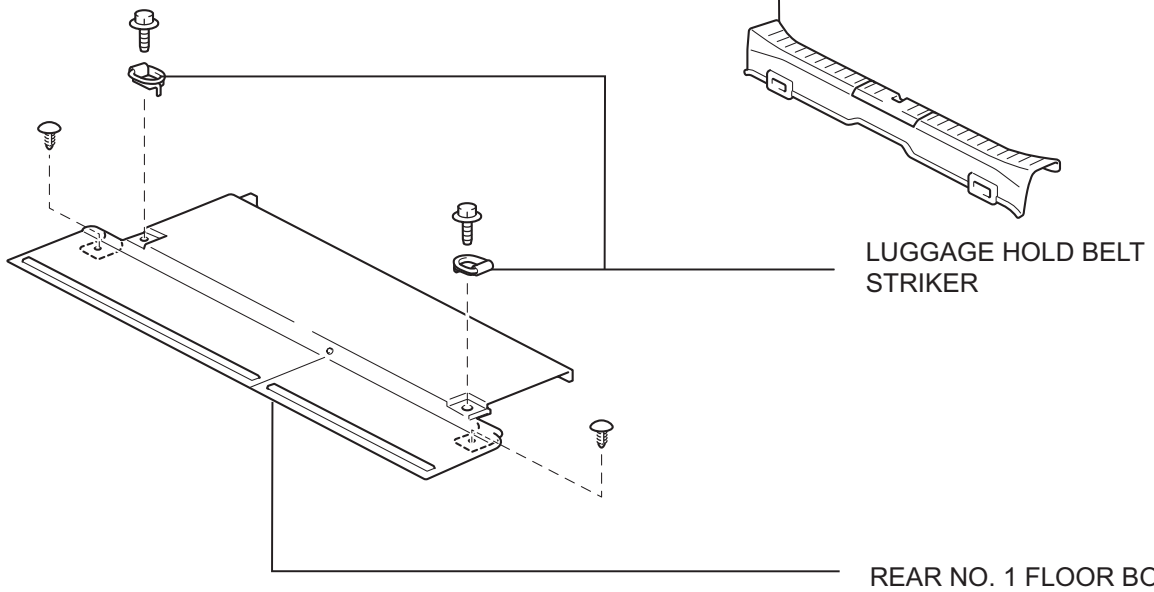
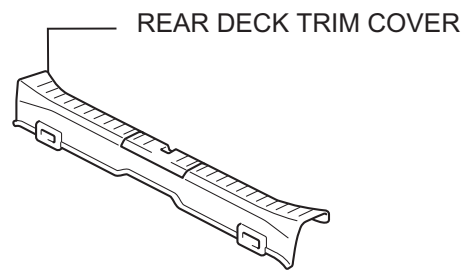
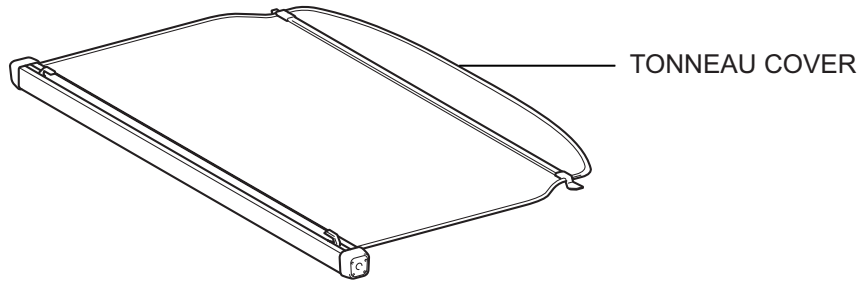

HV

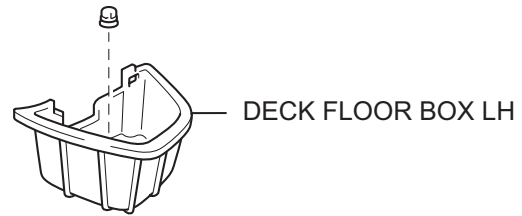
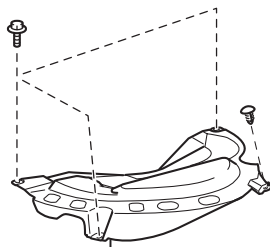
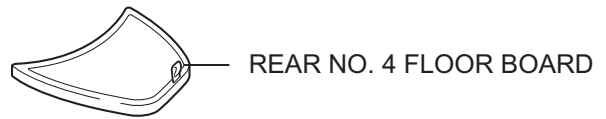
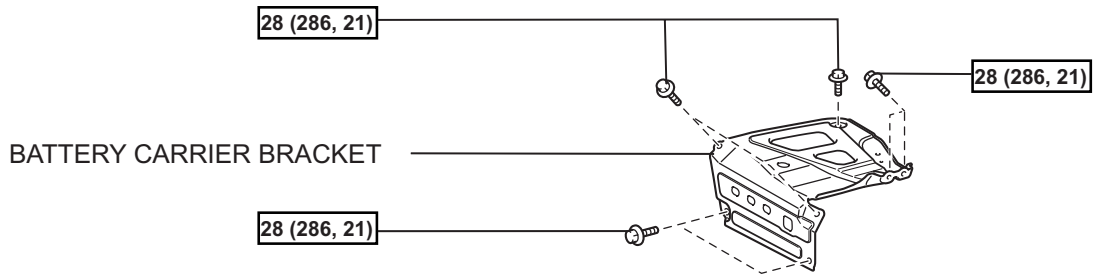

FLOOR SIDE PANEL LH

DECK TRIM SIDE PANEL LH

REAR SIDE SEATBACK FRAME LH

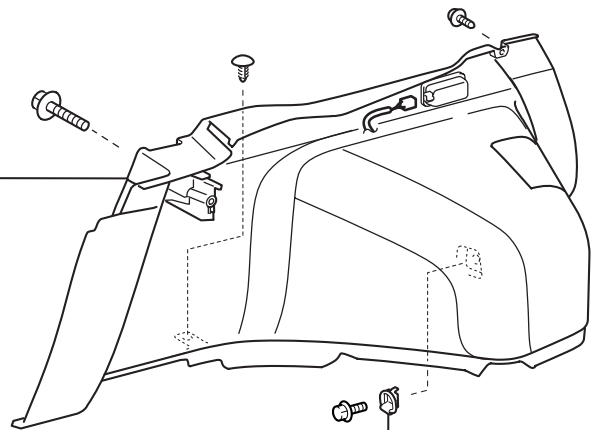

LUGGAGE HOLD BELT STRIKER

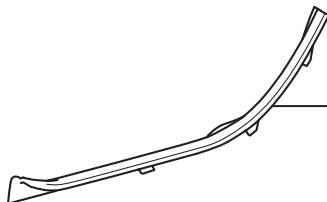

REAR DOOR SCUFF PLATE LH

N*m (kgf*cm, ft.*lbf) : Specified torque

HV

FRONT WIPER ARM RH

FRONT WIPER ARM COVER

FRONT WIPER ARM LH

21 (56, 16)

x 2

21 (56, 16)

HOOD TO COWL TOP SEAL

COWL TOP VENTILATOR LOUVER LH

COWL TOP VENTILATOR LOUVER RH

x 5 8.4 (86, 74 in.*lbf)

FRONT WIPER LINK AND WIPER MOTOR ASSEMBLY

WIPER MOTOR CONNECTOR

FRONT COWL TOP PANEL OUTER

6.4 (65, 57 in.*lbf)

NO. 2 ENGINE ROOM RELAY BLOCK

x 2

8.4 (86, 74 in.*lbf)

N*m (kgf*cm, ft.*lbf) : Specified torque

HV

COLUMN HOLE COVER SILENCER SHEET

35 (360, 26)

35 (360, 26)

STEERING INTERMEDIATE SHAFT

113 (1,152, 83)

113 (1,152, 83)

157 (1,601, 116)

FRONT FLOOR COVER CENTER LH

x 5

FRONT FLOOR COVER LH

ENGINE UNDER COVER RH

ENGINE UNDER COVER LH

N*m (kgf*cm, ft.*lbf) : Specified torque

HV

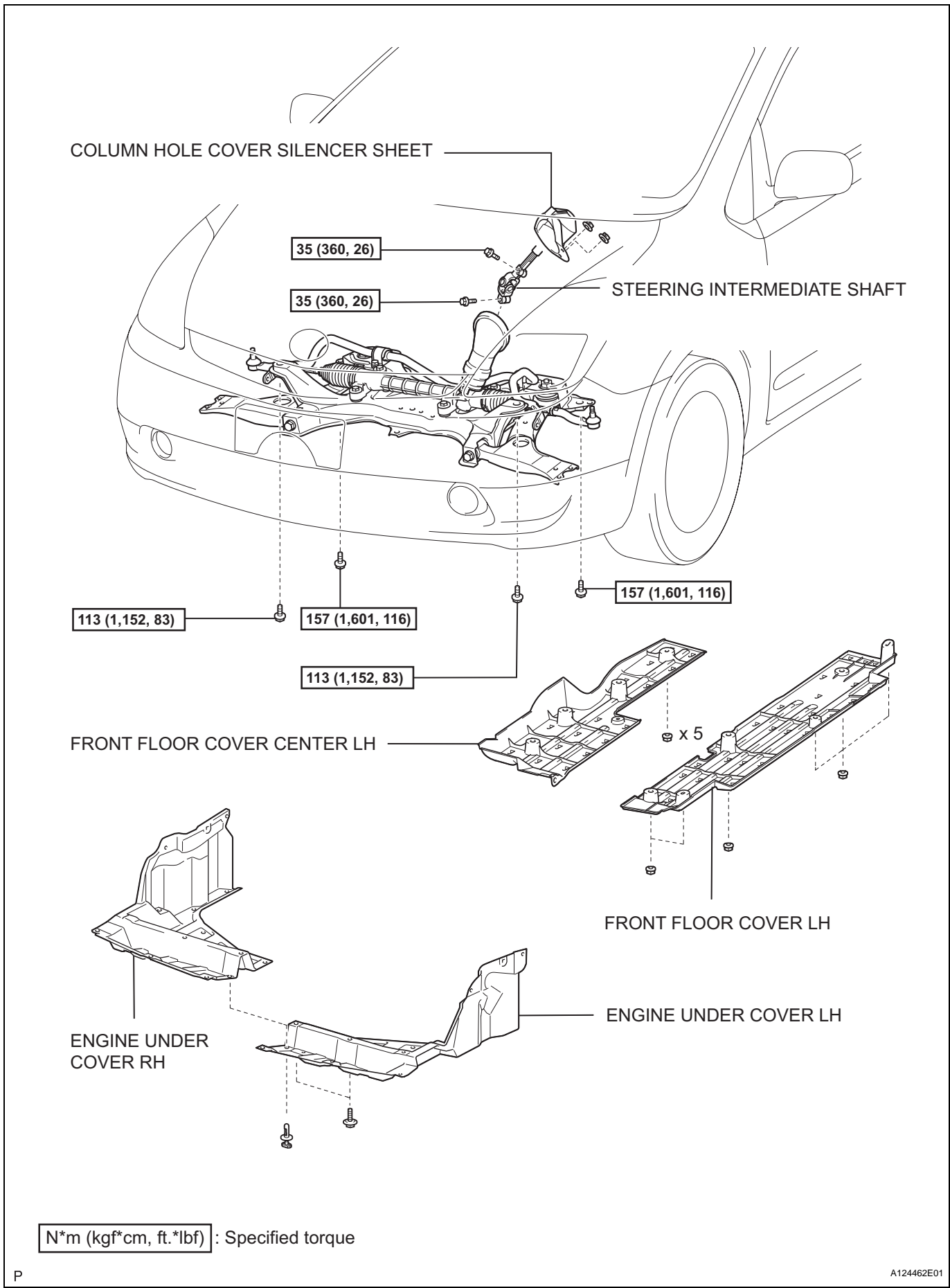

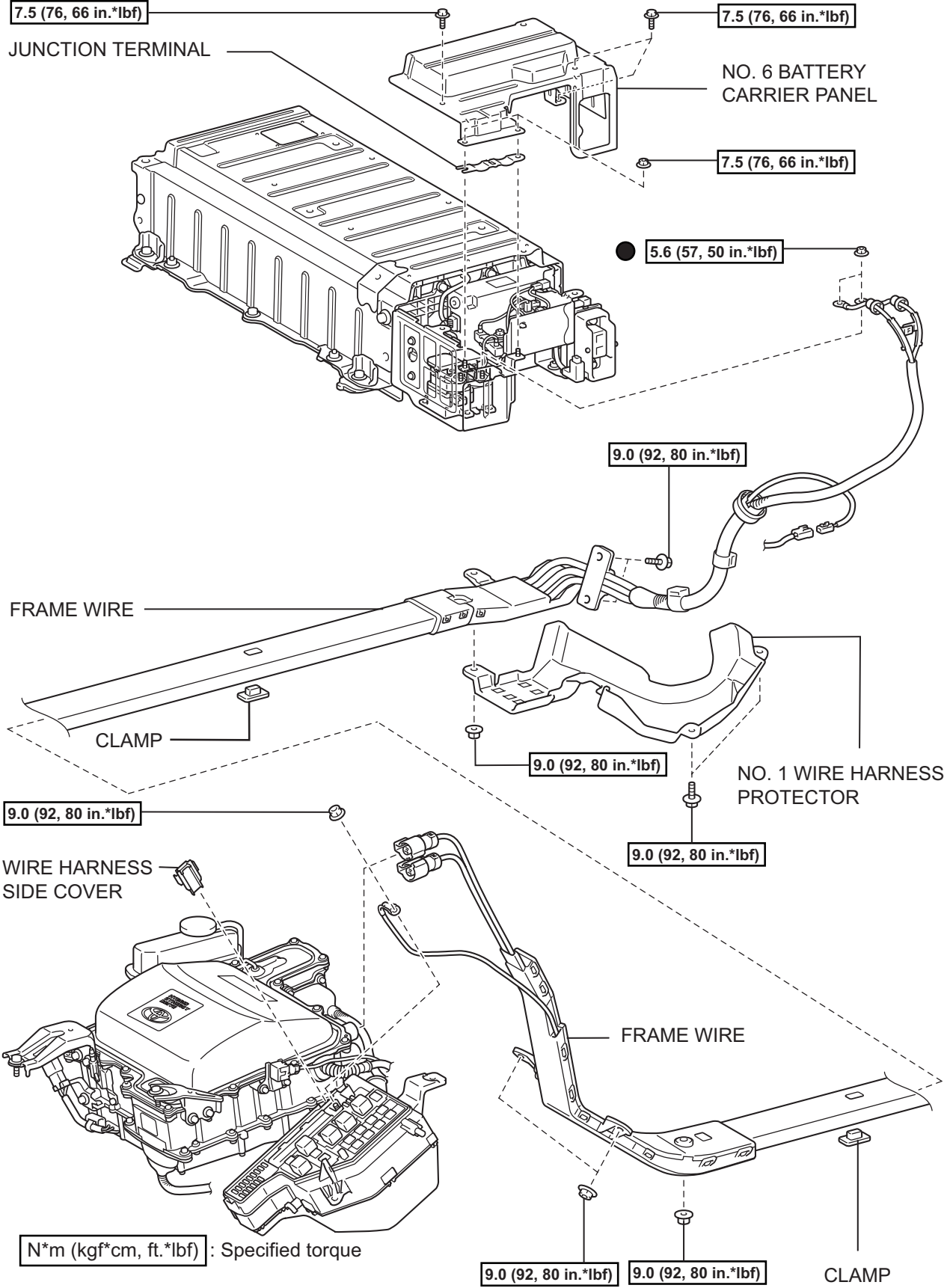

N*m (kgf*cm, ft.*lbf) : Specified torque

● Non-reusable part

HV

REMOVAL

CAUTION:

- When working on high voltage systems, always wear insulating gloves.
- Keep the removed service plug in your pocket to prevent other technicians from reconnecting it while you are servicing the vehicle.
- After removing the service plug grip, do not touch the high voltage connectors and terminals for 5 minutes.

NOTICE:

After removing the service plug grip, do not operate the power switch as it may damage the hybrid vehicle control ECU.

1. PRECAUTION

CAUTION:

The hybrid system uses high voltage circuits, so improper handling could cause an electric shock or leakage. During service (including installation/removal, inspection and replacement of parts), be sure to follow the procedures (see page [HV-519](#)).

2. REMOVE FRONT WHEEL

3. REMOVE REAR NO. 2 FLOOR BOARD (See page [CH-4](#))

4. REMOVE REAR DECK FLOOR BOX (See page [CH-4](#))

5. REMOVE REAR NO. 3 FLOOR BOARD (See page [CH-4](#))

6. DISCONNECT CABLE FROM NEGATIVE BATTERY TERMINAL

CAUTION:

Wait at least 90 seconds after disconnecting the cable from the negative (-) battery terminal to prevent airbag and seat belt pretensioner activation.

7. REMOVE SERVICE PLUG GRIP (See page [HB-154](#))

8. REMOVE REAR DECK TRIM COVER (See page [HB-88](#))

9. REMOVE TONNEAU COVER (See page [HB-89](#))

10. REMOVE REAR SEAT CUSHION ASSEMBLY (See page [SE-15](#))

11. REMOVE REAR NO. 1 FLOOR BOARD (See page [HB-89](#))

12. REMOVE REAR SIDE SEATBACK FRAME LH (See page [HB-89](#))

13. REMOVE REAR NO. 4 FLOOR BOARD (See page [HB-90](#))

14. REMOVE DECK FLOOR BOX LH (See page [HB-90](#))

15. REMOVE DECK TRIM SIDE PANEL LH (See page [HB-90](#))

16. REMOVE BATTERY CARRIER BRACKET (See page HB-91)

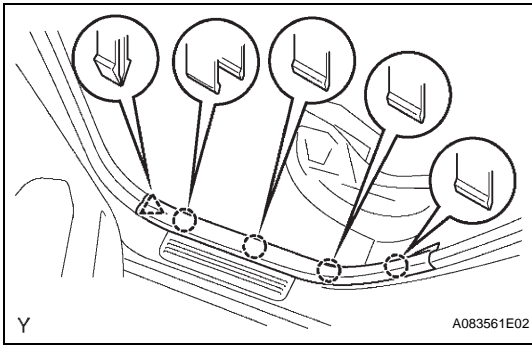

17. REMOVE REAR DOOR SCUFF PLATE LH

- (a) Remove the clip and 4 joints shown in the illustration, and then remove the rear door scuff plate.

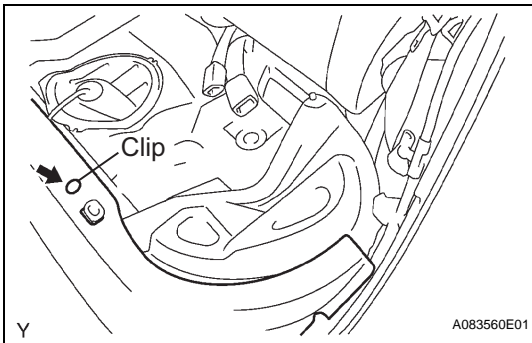

18. REMOVE FLOOR SIDE PANEL LH

- (a) Remove the clip, then roll back the carpet.

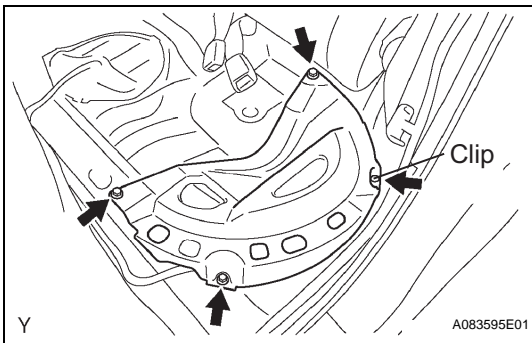

- (b) Remove the clip from the floor side panel.
- (c) Remove the 3 bolts and floor side panel.

19. REMOVE NO. 6 BATTERY CARRIER PANEL (See page HB-91)

20. REMOVE JUNCTION TERMINAL

CAUTION:
Wear insulating gloves.

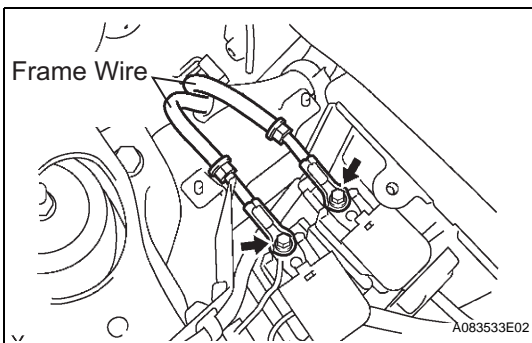

21. REMOVE FRAME WIRE

CAUTION:
Wear insulating gloves.

- (a) Remove the 2 nuts, then remove the frame wire from the No. 2 and No. 3 system main relay.

CAUTION:
Insulate the removed terminals with insulating tape.

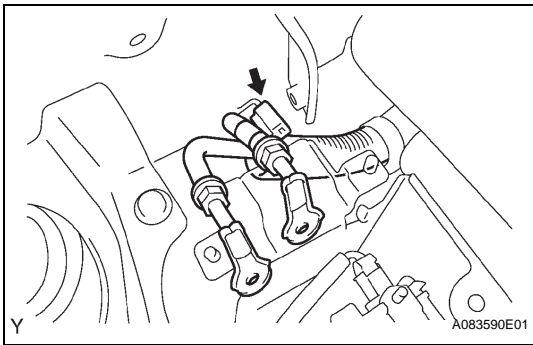

- (b) Remove the clamps, then remove the frame wire from the rear floor.

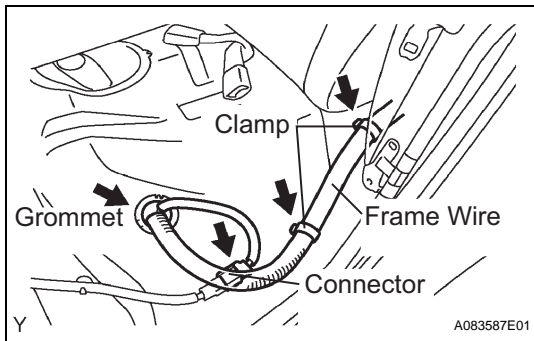

- (c) Remove the 2 clamps, then disconnect the frame wire from the center floor panel.
 (d) Disconnect the connector.
 (e) Disconnect the grommet.

22. REMOVE WINDSHIELD WIPER ARM COVER

23. REMOVE FRONT WIPER ARM LH (See page [WW-13](#))

24. REMOVE FRONT WIPER ARM RH (See page [WW-13](#))

25. REMOVE HOOD TO COWL TOP SEAL (See page [WW-13](#))

26. REMOVE COWL TOP VENTILATOR LOUVER LH (See page [WW-13](#))

27. REMOVE COWL TOP VENTILATOR LOUVER RH (See page [WW-13](#))

28. REMOVE FRONT WIPER LINK AND WIPER MOTOR ASSEMBLY (See page [WW-13](#))

29. REMOVE FRONT COWL TOP PANEL OUTER (See page [FU-12](#))

30. SEPARATE FRAME WIRE

CAUTION:

Wear insulating gloves.

- (a) Flip open the cover of the jump start terminal on the engine room relay block.

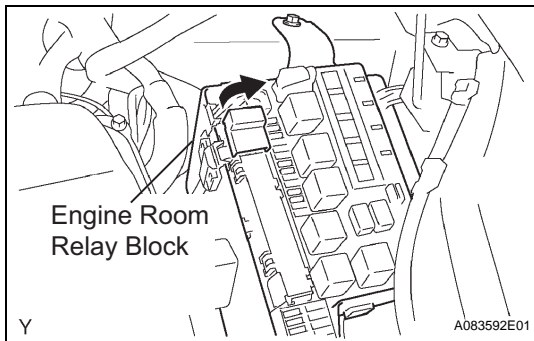

- (b) Remove the side cover by sliding it upward.

- (c) Remove the nut, then disconnect the frame wire from the engine room relay block.

- (d) Disconnect the clamp, then disconnect the frame wire from the side member.

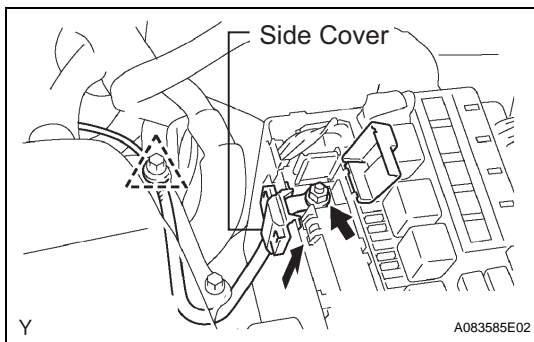

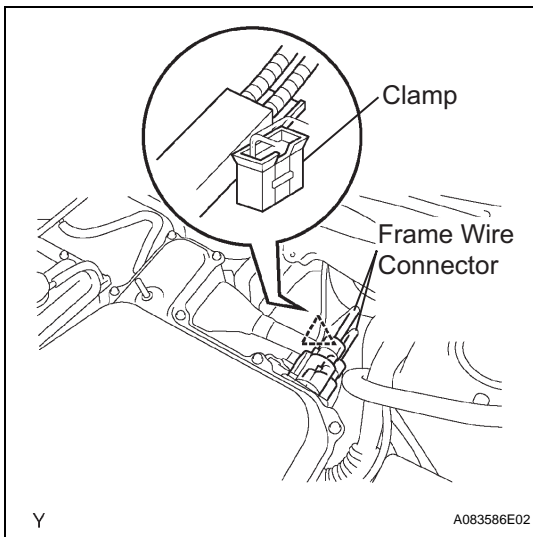

- (e) Remove the 2 frame wire connectors shown in the illustration from the inverter with converter assembly.
- (f) Disconnect the clamp, then disconnect the frame wire from the dash panel bracket.

31. REMOVE COLUMN HOLE COVER SILENCER SHEET (See page SR-10)

32. SEPARATE STEERING INTERMEDIATE SHAFT (See page SR-10)

33. REMOVE NO. 3 ENGINE UNDER COVER

34. REMOVE NO. 4 ENGINE UNDER COVER CENTER (See page ET-3)

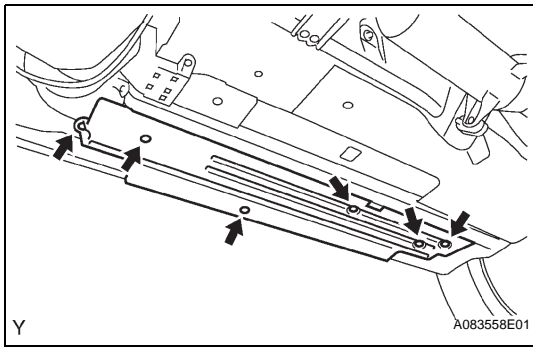

35. REMOVE FRONT FLOOR COVER LH

- (a) Remove the 6 clips and front floor cover LH.

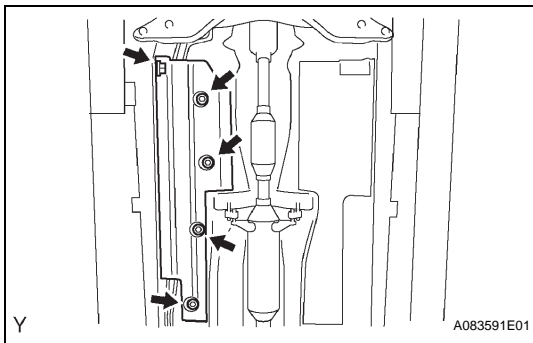

36. REMOVE FRONT FLOOR COVER CENTER LH

- (a) Remove the 5 clips and front floor cover center LH.

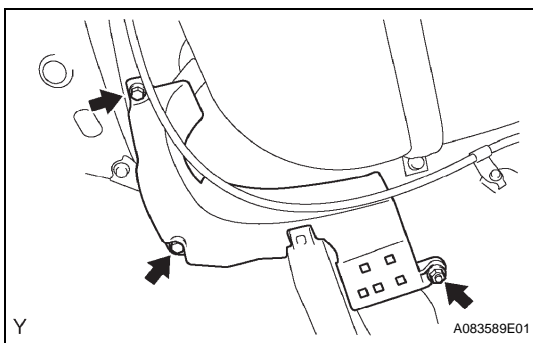

37. REMOVE NO. 1 WIRE HARNESS PROTECTOR

CAUTION:

Wear insulating gloves.

- (a) Remove the 2 nuts, bolt and wire harness protector.

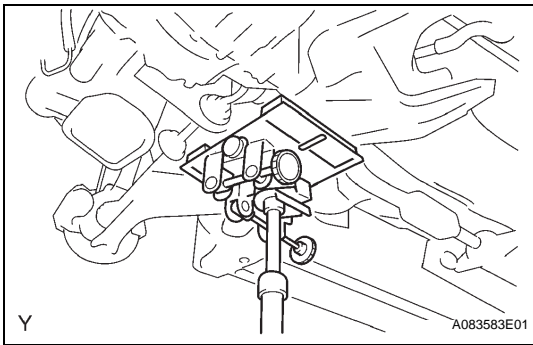

- 38. SEPARATE FRONT SUSPENSION CROSSMEMBER**
 (a) Support the front suspension crossmember using a jack.

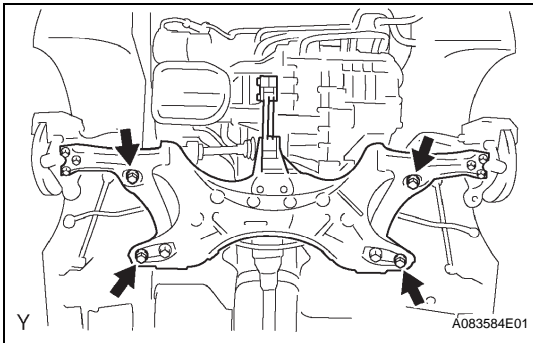

- (b) Remove the 4 bolts shown in the illustration from the front suspension crossmember.

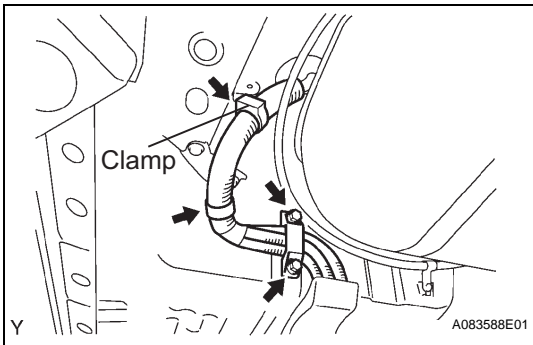

39. REMOVE FRAME WIRE

CAUTION:

Wear insulating gloves.

- (a) Remove the 2 bolts shown in the illustration.
 (b) Disconnect the 2 clamps.
 (c) Lower the jack a little and remove both nuts labeled A.

NOTICE:

- Lower the jack slowly to avoid interfering with objects loaded on the front suspension crossmember.
- Do not remove the jack.

- (d) Remove both nuts labeled B.
 (e) Disconnect the fit-in clamps, then remove the frame wire.

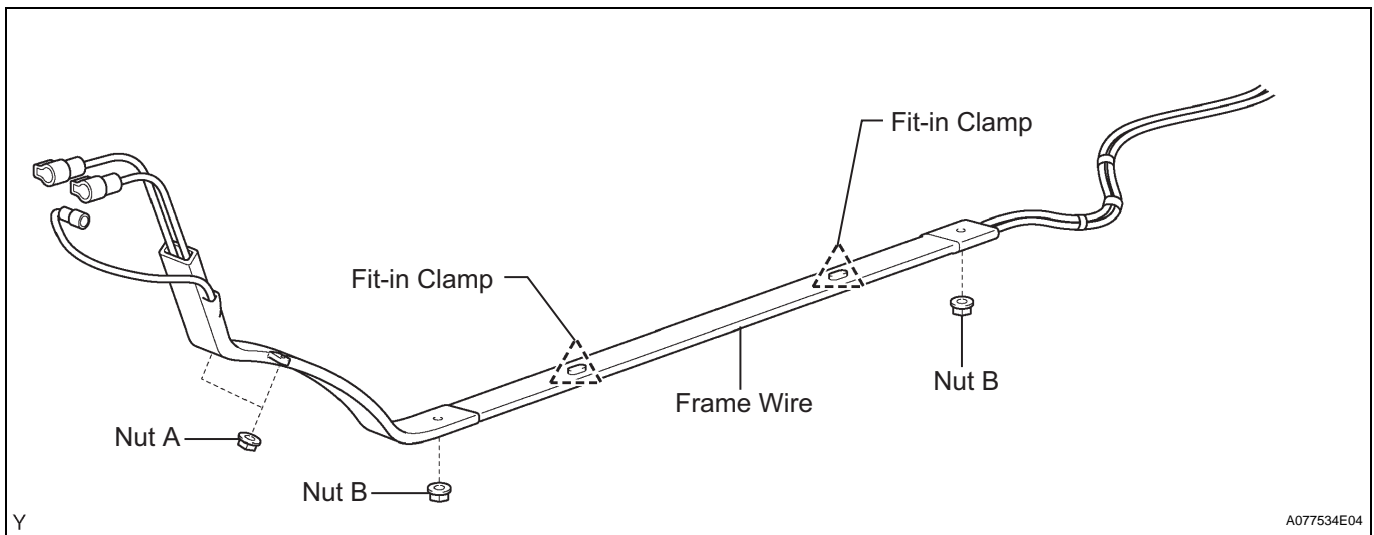

HV

INSTALLATION

1. INSTALL FRAME WIRE

CAUTION:

Wear insulating gloves.

- (a) Temporarily fasten the frame wire to the vehicle.
- (b) Connect the fit-in clamps to the stud in the floor panel, and then install the frame wire with both nuts labeled A.

Torque: 9.0 N*m (92 kgf*cm, 80 in.*lbf)

- (c) Install both nuts labeled B shown in the illustration.

Torque: 9.0 N*m (92 kgf*cm, 80 in.*lbf)

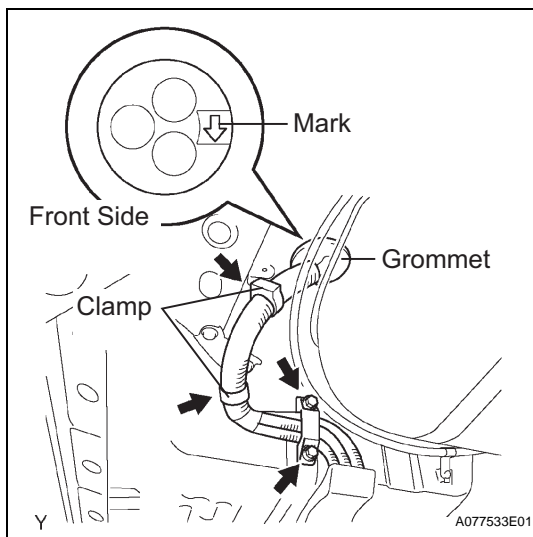
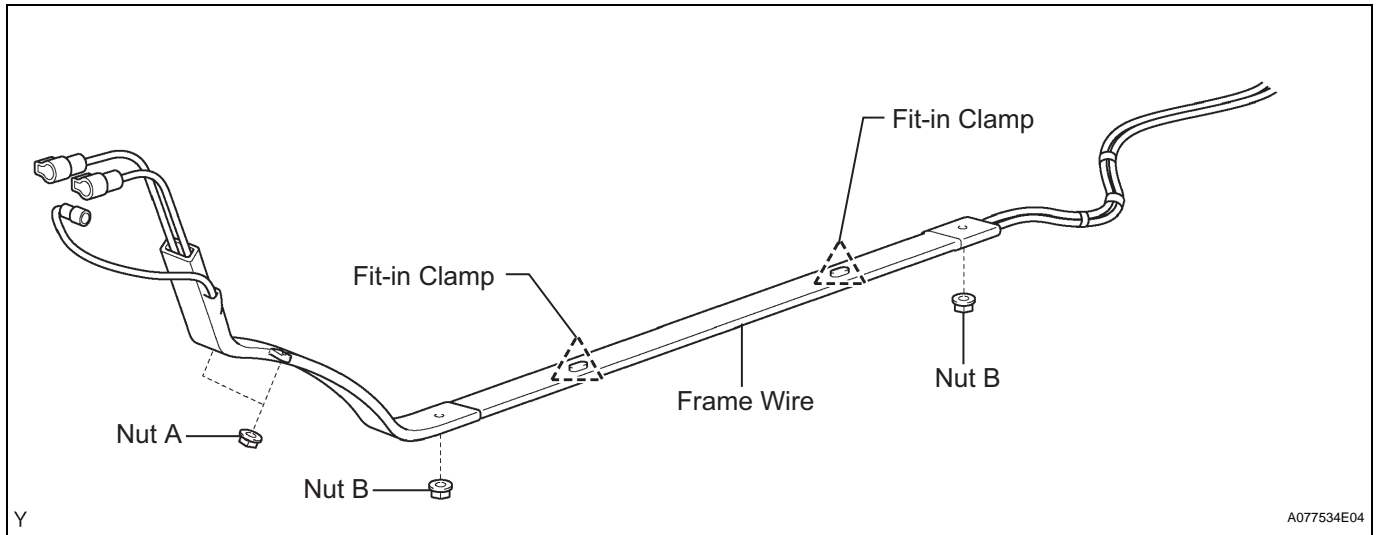

- (d) As shown in the illustration, point the arrow on the grommet in the front direction, then install the grommet.

- (e) Install the 2 bolts.

Torque: 9.0 N*m (92 kgf*cm, 80 in.*lbf)

- (f) Install the 2 clamps.

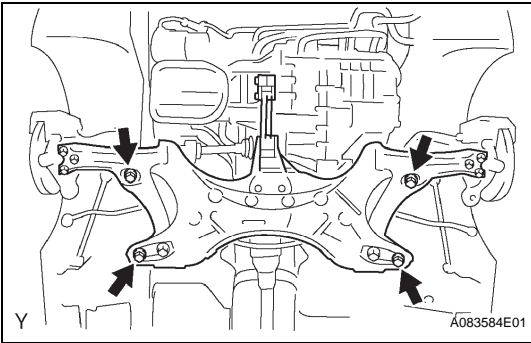

2. INSTALL FRONT SUSPENSION CROSSMEMBER

- (a) Install the front suspension crossmember with the 4 bolts.

Torque: 113 N*m (1,152 kgf*cm, 83 in.*lbf) for bolt A

157 N*m (1,601 kgf*cm, 116 in.*lbf) for bolt B

- (b) Remove the jack.

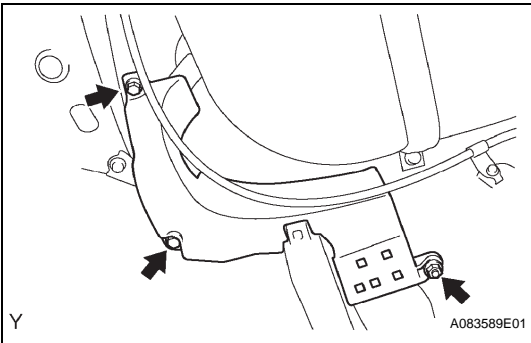

3. INSTALL NO. 1 WIRE HARNESS PROTECTOR

CAUTION:
Wear insulating gloves.

- (a) Install the wire harness protector with the 2 bolts and nut.

Torque: 9.0 N*m (92 kgf*cm, 80 in.*lbf)

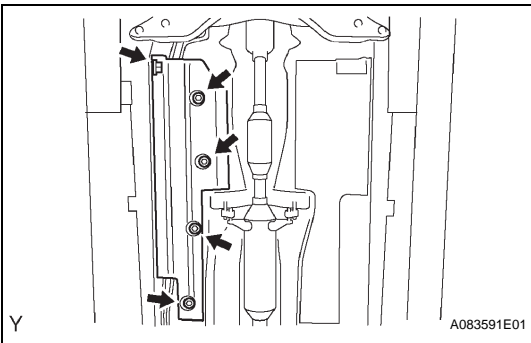

4. INSTALL FRONT FLOOR COVER CENTER LH

- (a) Install the floor cover with the 5 clips.

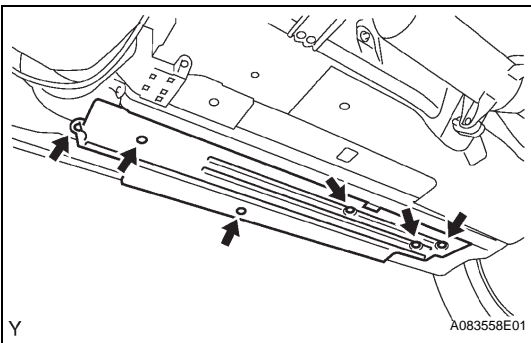

5. INSTALL FRONT FLOOR COVER LH

- (a) Install the floor cover with the 6 clips.

6. INSTALL NO. 3 ENGINE UNDER COVER

7. INSTALL NO. 4 ENGINE UNDER COVER CENTER

8. INSTALL STEERING INTERMEDIATE SHAFT (See page [EM-107](#))

9. INSTALL COLUMN HOLE COVER SILENCER SHEET

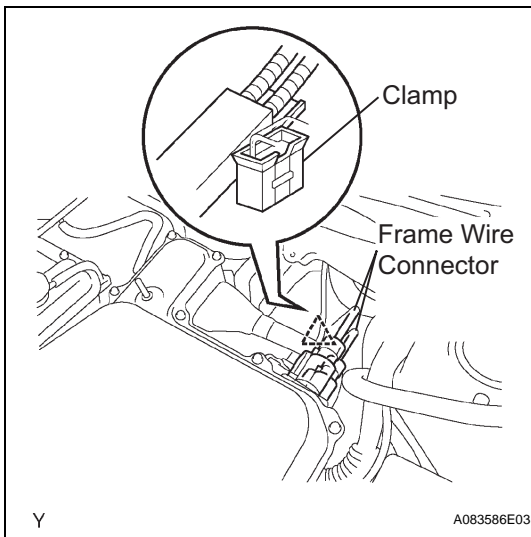
**10. INSTALL FRAME WIRE****CAUTION:****Wear insulating gloves.**

- (a) Connect the 2 connectors shown in the illustration to the inverter with converter assembly.
- (b) Connect the clamp to the engine room relay block with the nut.

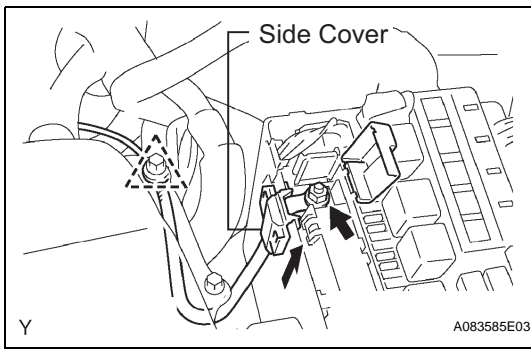

- (c) Install the frame wire to the engine room relay block with the nut.

Torque: 9.0 N*m (92 kgf*cm, 80 in.*lbf)

- (d) Install the side cover to the engine room relay block.
- (e) Install the frame wire clamp to the side member.

11. INSTALL FRONT COWL TOP PANEL OUTER (See page [FU-19](#))**12. INSTALL FRONT WIPER LINK AND WIPER MOTOR ASSEMBLY (See page [WW-16](#))****13. INSTALL COWL TOP VENTILATOR LOUVER RH****14. INSTALL COWL TOP VENTILATOR LOUVER LH****15. INSTALL HOOD TO COWL TOP SEAL****16. INSTALL FRONT WIPER ARM LH (See page [WW-16](#))****17. INSTALL FRONT WIPER ARM RH (See page [WW-16](#))****18. INSTALL FRONT WIPER ARM COVER****19. INSTALL FRAME WIRE****CAUTION:****Wear insulating gloves.**

- (a) Connect the grommet.
- (b) Connect the connector.
- (c) Install the 2 clamps, then connect the frame wire to the center floor panel.

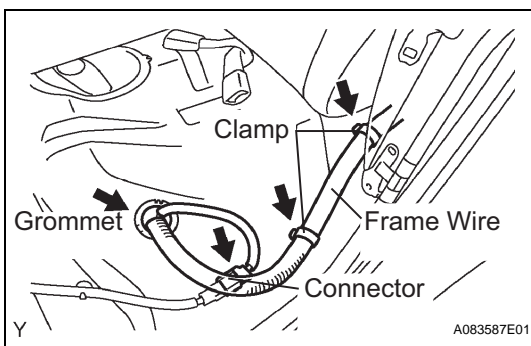

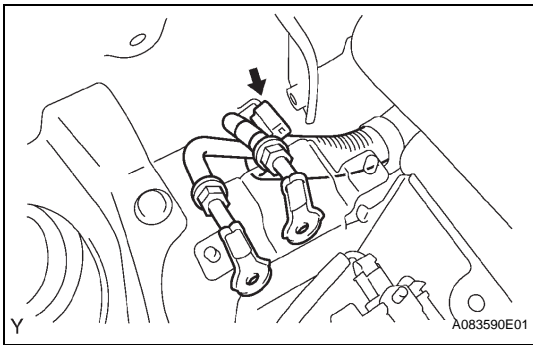

- (d) Install the frame wire to the rear floor panel with the clamp.

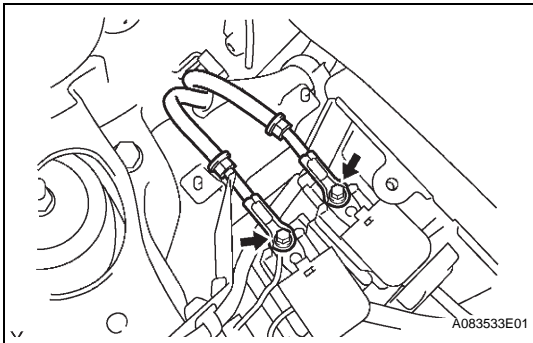

- (e) Install the frame wire to the No. 2 and No. 3 system main relay with 2 new nuts.

Torque: 5.6 N*m (57 kgf*cm, 50 in.*lbf)

20. INSTALL JUNCTION TERMINAL

CAUTION:

Wear insulating gloves.

21. INSTALL NO. 6 BATTERY CARRIER PANEL (See page [HB-97](#))

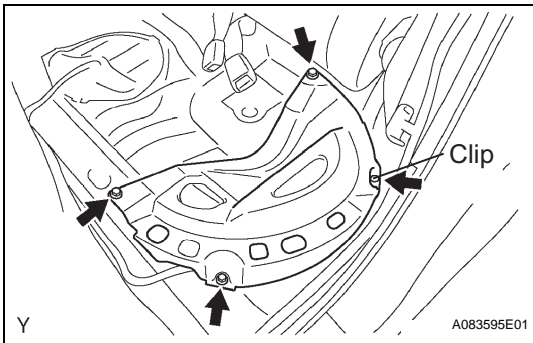

22. INSTALL FLOOR SIDE PANEL LH

- (a) Install the clip.

- (b) Install the floor side panel with the 3 bolts.

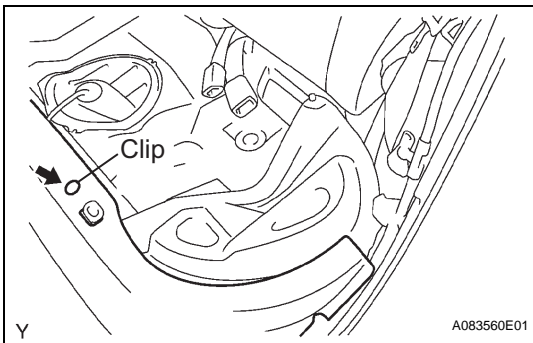

- (c) Install the carpet with the clip.

23. INSTALL REAR DOOR SCUFF PLATE LH

24. INSTALL BATTERY CARRIER BRACKET (See page [HB-97](#))

25. INSTALL DECK TRIM SIDE PANEL LH (See page [HB-98](#))

26. INSTALL DECK FLOOR BOX LH (See page [HB-98](#))

27. INSTALL REAR NO. 4 FLOOR BOARD (See page [HB-98](#))

28. INSTALL REAR SIDE SEATBACK FRAME LH (See page [HB-99](#))

29. INSTALL REAR NO. 1 FLOOR BOARD (See page [HB-99](#))

30. INSTALL REAR SEAT CUSHION ASSEMBLY (See page [HB-99](#))

31. INSTALL TONNEAU COVER (See page [HB-99](#))

32. INSTALL REAR DECK TRIM COVER (See page [HB-100](#))
33. INSTALL SERVICE PLUG GRIP (See page [HB-154](#))
34. CONNECT CABLE TO NEGATIVE BATTERY TERMINAL (See page [CH-7](#))
35. INSTALL REAR NO. 3 FLOOR BOARD (See page [CH-8](#))
36. INSTALL REAR DECK FLOOR BOX (See page [CH-8](#))
37. INSTALL REAR NO. 2 FLOOR BOARD (See page [CH-8](#))
38. INSTALL FRONT WHEEL
39. PERFORM INITIALIZATION
 - (a) Perform initialization (see page [IN-32](#)).

NOTICE:

Certain systems need to be initialized after disconnecting and reconnecting the cable from the negative (-) battery terminal.

ACCELERATOR PEDAL ROD

COMPONENTS

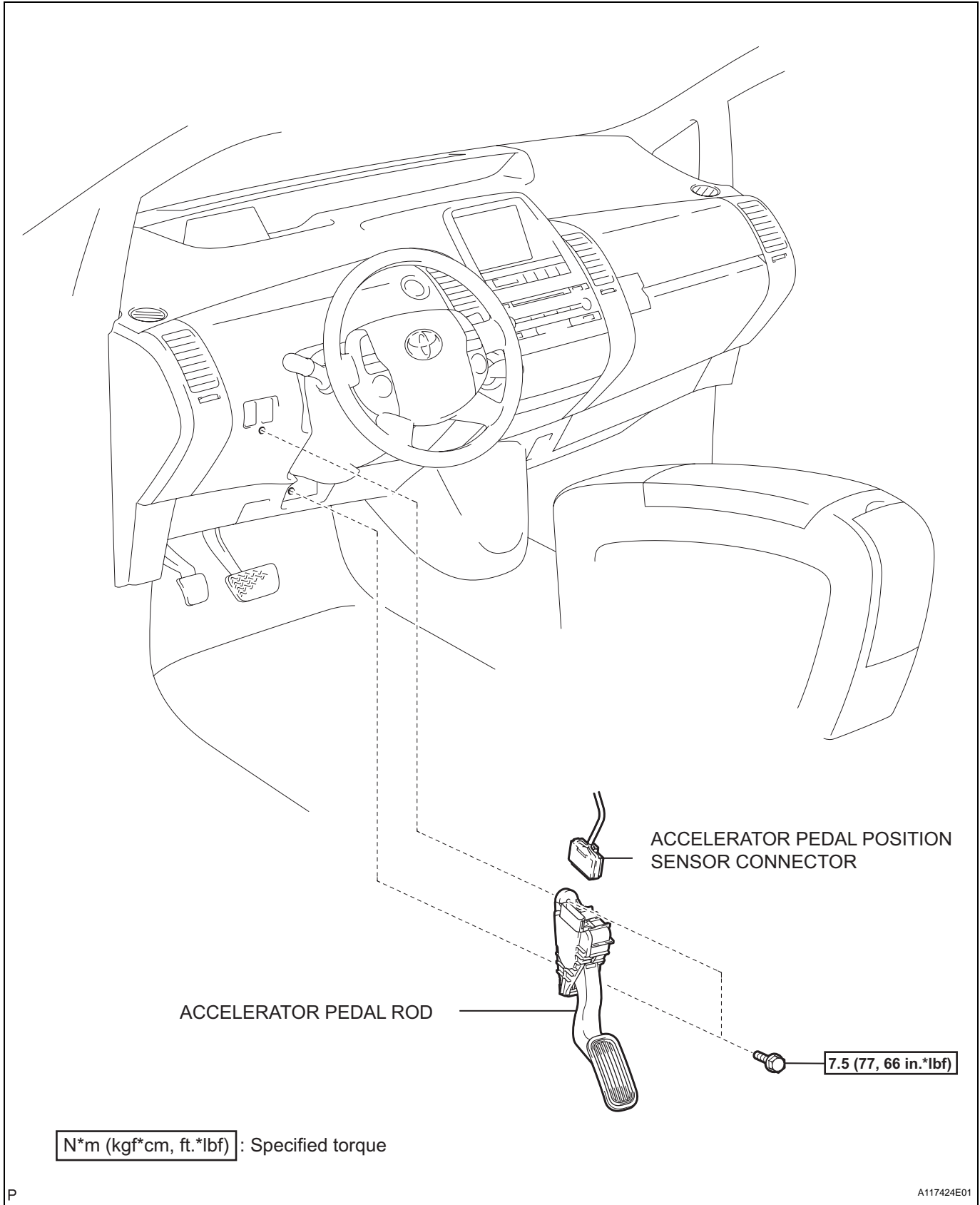

HV

ON-VEHICLE INSPECTION

1. INSPECT ACCELERATOR PEDAL ROD

NOTICE:

- Do not remove the accelerator pedal position sensor from the accelerator pedal.
 - Perform the inspection on the hybrid vehicle control ECU side of the connector.
- (a) Turn the power switch ON (IG).
 - (b) Using a voltmeter, measure the voltage between the terminals.

Standard voltage

Tester Connection	Measuring Condition	Specified Condition
B-25 (VCP) - B-27 (EP1)	Normal	4.5 to 5.5 V
B-26 (VPA1) - B-27 (EP1)	Do not depress the accelerator pedal	0.5 to 1.1 V
B-26 (VPA1) - B-27 (EP1)	Gradually depress the accelerator pedal	The voltage increases slowly
B-26 (VPA1) - B-27 (EP1)	Fully depress the accelerator pedal	2.6 to 4.5 V
B-33 (VCP2) - B-35 (EP2)	Normal	4.5 to 5.5 V
B-34 (VPA2) - B-35 (EP2)	Do not depress the accelerator pedal	1.2 to 2.0 V
B-34 (VPA2) - B-35 (EP2)	Gradually depress the accelerator pedal	The voltage increases slowly
B-34 (VPA2) - B-35 (EP2)	Fully depress the accelerator pedal	3.4 to 5.3 V

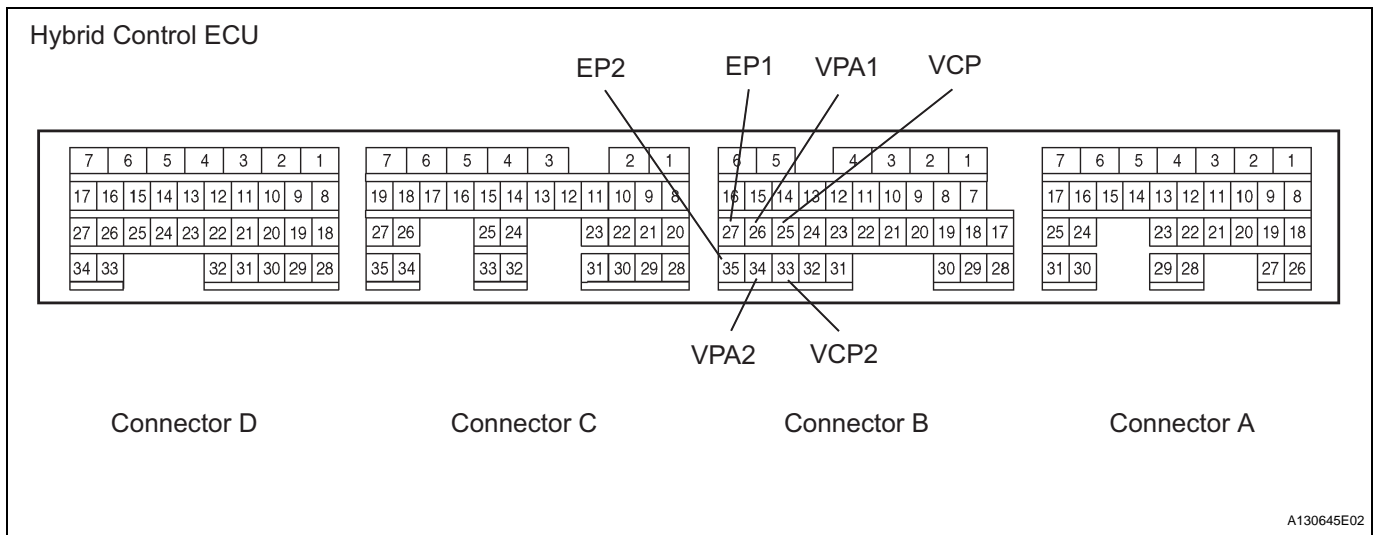

If the standards are not met, replace the accelerator pedal rod.

REMOVAL

1. REMOVE REAR NO. 2 FLOOR BOARD (See page [CH-4](#))
2. REMOVE REAR DECK FLOOR BOX (See page [CH-4](#))
3. REMOVE REAR NO. 3 FLOOR BOARD (See page [CH-4](#))
4. DISCONNECT CABLE FROM NEGATIVE BATTERY TERMINAL
CAUTION:
 Wait at least 90 seconds after disconnecting the cable from the negative (-) battery terminal to prevent airbag and seat belt pretensioner activation.
5. REMOVE ACCELERATOR PEDAL ROD
 - (a) Disconnect the accelerator pedal position sensor connector.
 - (b) Remove the 2 bolts, then remove the accelerator pedal rod.

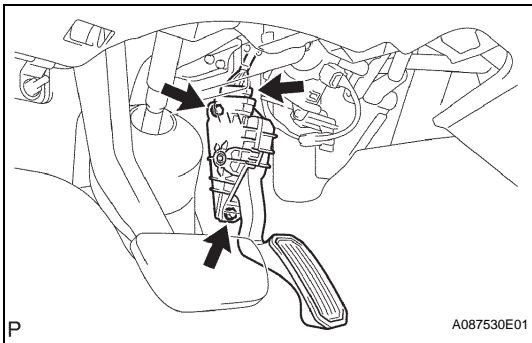
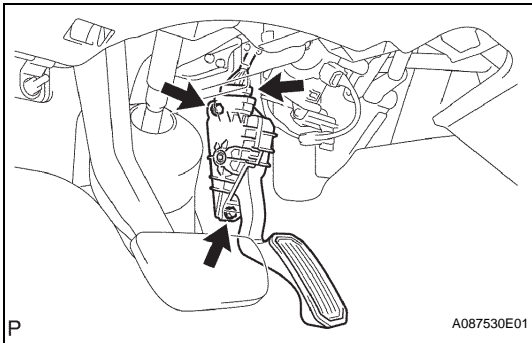

INSTALLATION

1. INSTALL ACCELERATOR PEDAL ROD
 - (a) Install the accelerator pedal rod with the 2 bolts.
Torque: 7.5 N*m (77 kgf*cm, 66 in.*lbf)
 - (b) Connect the accelerator pedal position sensor connector.
2. CONNECT CABLE TO NEGATIVE BATTERY TERMINAL (See page [CH-7](#))
3. INSTALL REAR NO. 3 FLOOR BOARD (See page [CH-8](#))
4. INSTALL REAR DECK FLOOR BOX (See page [CH-8](#))
5. INSTALL REAR NO. 2 FLOOR BOARD (See page [CH-8](#))
6. PERFORM INITIALIZATION
 - (a) Perform initialization (see page [IN-32](#)).
NOTICE:
 Certain systems need to be initialized after disconnecting and reconnecting the cable from the negative (-) battery terminal.

IGCT RELAY

ON-VEHICLE INSPECTION

1. DISCONNECT CABLE FROM NEGATIVE BATTERY TERMINAL

CAUTION:

Wait at least 90 seconds after disconnecting the cable from the negative (-) battery terminal to prevent airbag and seat belt pretensioner activation.

2. INSPECT INTEGRATION RELAY (IGCT RELAY)

NOTICE:

IGCT relay is built into the integration relay.

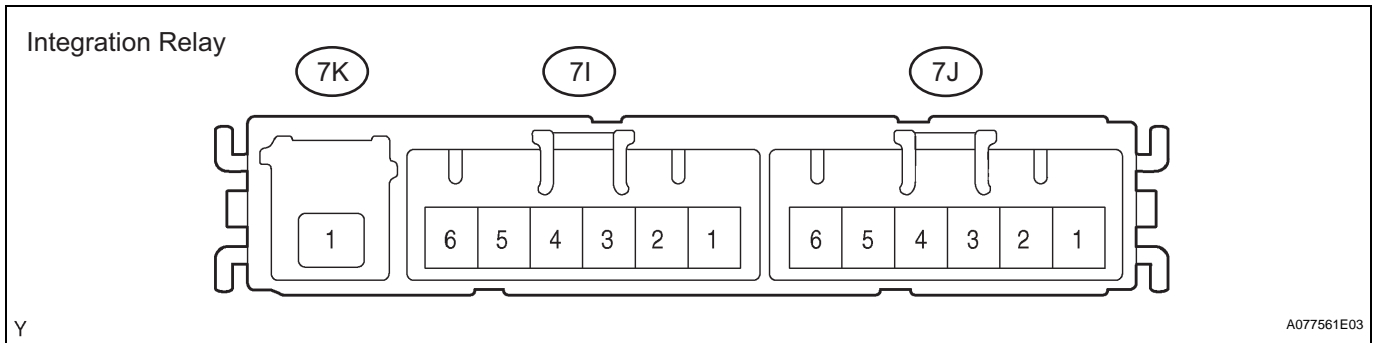

- (a) Check the resistance of the HEV fuse.
If the result is not as specified, replace the fuse.
- (b) Measure the resistance of the IGCT relay.

Standard resistance

Tester Connection	Specified Condition
7J-1 - 7J-4	10 kΩ or higher
7J-1 - 7K-4	Below 1 Ω
7J-2 - 7J-3	Below 1 Ω
7J-4 - 7K-1	10 kΩ or higher
7J-1 - 7J-4	Below 1 Ω (when battery voltage is applied to terminals 7J-2 and 7J-3)
7J-1 - 7K-1	Below 1 Ω (when battery voltage is applied to terminals 7J-2 and 7J-3)

If the standards are not met, replace the integration relay.