

FOREWORD

This repair manual has been prepared to provide essential information on body panel repair methods (including cutting and welding operations, but excluding painting) for the TOYOTA PRIUS.

Applicable models: NHW 20 series

This manual consists of body repair methods, exploded diagrams and illustrations of the body components and other information relating to body panel replacement such as handling precautions, etc. However, it should be noted that the front fenders of the TOYOTA model is bolted on and require no welding.

When repairing, don't cut and join areas that are not shown in this manual. Only work on the specified contents to maintain body strength.

Body construction will sometimes differ depending on specifications and country of destination. Therefore, please keep in mind that the information contained herein is based on vehicles for general destinations.

For the repair procedures and specifications other than collision-damaged body components of the TOYOTA PRIUS refer to the repair manuals.

If you require the above manuals, please contact your TOYOTA Dealer.

All information contained in this manual is the most up-to-date at the time of publication. However, specifications and procedures are subject to change without prior notice.

TOYOTA MOTOR CORPORATION

NOTE: The Vehicle Lift and Support Locations sections and For Vehicles Equipped With SRS Airbag and Seat Belt Pretensioner sections refer to the TOYOTA PRIUS Repair Manual.

VIEWS OF THIS TEXT

Scope of the repair work explanation

- This text explains the welding panel replacement instructions from the vehicle's white body condition. We have abbreviated the explanations of the removal and reinstallation of the equipment parts up to the white body condition and of the installation, inspection, adjustment and final inspection of equipment parts after replacing the weld panel.

Section categories

- Each section has been divided as shown below.

Section Title	Contents	Examples
INTRODUCTION	Explanation of general body repair. Views of weld panel replacement instructions.	Cautionary items. Views of weld panel replacement instructions.
BODY PANEL REPLACEMENT	Instructions for replacing the weld panels from the white body condition, from which bolted parts have been removed, with individual supply parts.	Front side member replacement. Quarter panel replacement.
BODY DIMENSIONS	Body aligning measurements.	Dimension diagrams.
PAINT • COATING	Scope and type of anti-rust treatment, etc. together with weld panel replacement.	Under coat. Body sealer.

Abbreviation of contents in this text.

- The following essential procedures have been abbreviated. When actually working, conduct this work properly.
 - (1) Jack and lift operations.
 - (2) Clean and wash removed parts, if necessary.
 - (3) Visual inspection.

NOTE: The Vehicle Lift and Support Locations sections and For Vehicles Equipped With SRS Airbag and Seat Belt Pretensioner sections refer to the TOYOTA PRIUS Repair Manual.

GENERAL REPAIR INSTRUCTIONS

1. WORK PRECAUTIONS

(a) VEHICLE PROTECTION

- (1) When welding, protect the painted surfaces, windows, seats and carpet with heat resistant, fire-proof covers.

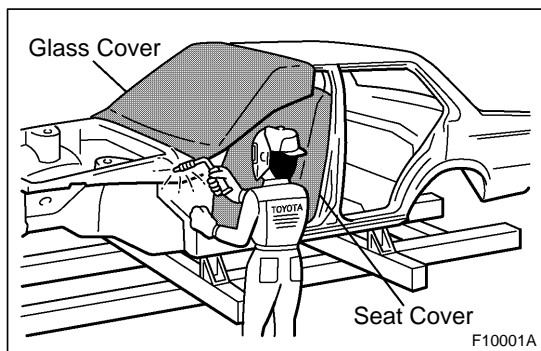

(b) SAFETY

- (1) Never stand in direct line with the chain when using a puller on the body or frame, and be sure to attach a safety cable.

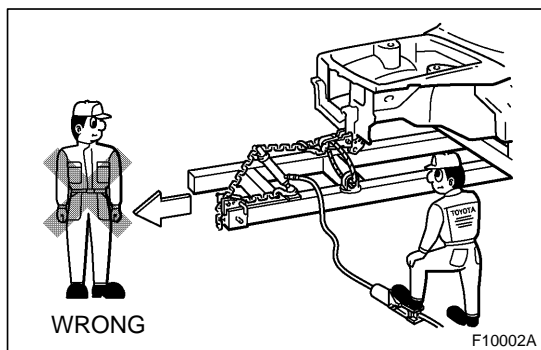

- (2) Before performing repair work, check for fuel leaks. If a leak is found, be sure to close the opening totally.
- (3) If it is necessary to use a flame in the area of the fuel tank, first remove the tank and plug the fuel line.

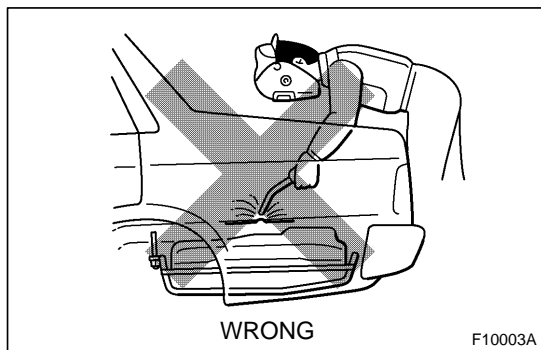

(c) SAFETY WORK CLOTHES

- (1) In addition to the usual mechanic's wear, cap and safety shoes, the appropriate gloves, head protector, glasses, ear plugs, face protector, dust-prevention mask, etc. should be worn as the situation demands.

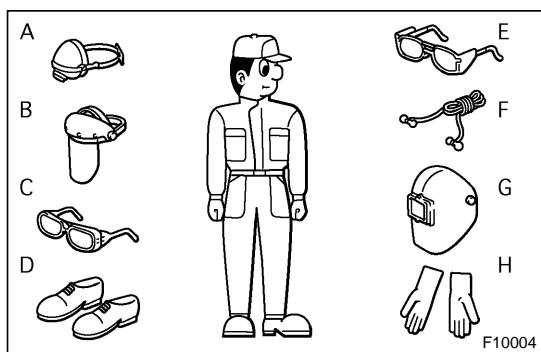

Code	Name
A	Dust-Prevention Mask
B	Face Protector
C	Eye Protector
D	Safety Shoes
E	Welder's Glasses
F	Ear Plugs
G	Head Protector
H	Welder's Gloves

2. HANDLING PRECAUTIONS OF PLASTIC BODY PARTS

- (1) The repair procedure for plastic body parts must conform with the type of plastic material.
- (2) Plastic body parts are identified by the codes in the following table.
- (3) When repairing metal body parts adjoining plastic body parts (by brazing, frame cutting, welding, painting etc.), consideration must be given to the property of the plastic.

Code	Material name	Heat* resistant temperature limit °C (°F)	Resistance to alcohol or gasoline	Notes
AAS	Acrylonitrile Acrylic Styrene	80 (176)	Alcohol is harmless if applied only for short time in small amounts (e.g., quick wiping to remove grease).	Avoid gasoline and organic or aromatic solvents.
ABS	Acrylonitrile Butadiene Styrene	80 (176)	Alcohol is harmless if applied only for short time in small amounts (e.g., quick wiping to remove grease).	Avoid gasoline and organic or aromatic solvents.
AES	Acrylonitrile Ethylene Styrene	80 (176)	Alcohol is harmless if applied only for short time in small amounts (e.g., quick wiping to remove grease).	Avoid gasoline and organic or aromatic solvents.
ASA	Acrylonitrile Styrene Acrylate	80 (176)	Alcohol is harmless if applied only for short time in small amounts (e.g., quick wiping to remove grease).	Avoid gasoline and organic or aromatic solvents.
CAB	Cellulose Acetate	80 (176)	Alcohol is harmless if applied only for short time in small amounts (e.g., quick wiping to remove grease).	Avoid gasoline and organic or aromatic solvents.
EPDM	Ethylene Propylene	100 (212)	Alcohol is harmless. Gasoline is harmless if applied only for short time in small amounts.	Most solvents are harmless but avoid dipping in gasoline, solvents, etc.
FRP	Fiber Reinforced Plastics	180 (356)	Alcohol and gasoline are harmless.	Avoid alkali.
EVA	Ethylene Acetate	70 (158)	Alcohol is harmless if applied only for short time in small amounts (e.g., quick wiping to remove grease).	Avoid gasoline and organic or aromatic solvents.
PA	Polyamide (Nylon)	80 (176)	Alcohol and gasoline are harmless.	Avoid battery acid.
PBT	Polybutylene Terephthalate	160 (320)	Alcohol and gasoline are harmless.	Most solvents are harmless.
PC	Polycarbonate	120 (248)	Alcohol is harmless.	Avoid gasoline brake fluid, wax, wax removers and organic solvents. Avoid alkali.

*Temperatures higher than those listed here may result in material deformation during repair.

Code	Material name	Heat* resistant temperature limit °C (°F)	Resistance to alcohol or gasoline	Notes
PE	Polyethylene	80 (176)	Alcohol and gasoline are harmless.	Most solvents are harmless.
PET	Polyethylene Terephthalate	75 (167)	Alcohol and gasoline are harmless.	Avoid dipping in water.
PMMA	Polymethyl Methacrylate	80 (176)	Alcohol is harmless if applied only for short time in small amounts.	Avoid dipping or immersing in alcohol, gasoline, solvents, etc.
POM	Polyoxymethylene (Polyacetal)	100 (212)	Alcohol and gasoline are harmless.	Most solvents are harmless.
PP	Polypropylene	80 (176)	Alcohol and gasoline are harmless.	Most solvents are harmless.
PPO	Modified Polyphenylene Oxide	100 (212)	Alcohol is harmless.	Gasoline is harmless if applied only for quick wiping to remove grease.
PS	Polystyrene	60 (140)	Alcohol and gasoline are harmless if applied only for short time in small amounts.	Avoid dipping or immersing in alcohol, gasoline, solvents, etc.
PUR	Polyurethane	80 (176)	Alcohol is harmless if applied only for very short time in small amounts (e.g., quick wiping to remove grease).	Avoid dipping or immersing in alcohol, gasoline, solvents, etc.
PVC	Polyvinylchloride (Vinyl)	80 (176)	Alcohol and gasoline are harmless if applied only for short time in small amounts (e.g., quick wiping to remove grease).	Avoid dipping or immersing in alcohol, gasoline, solvents, etc.
SAN	Styrene Acrylonitrile	80 (176)	Alcohol is harmless if applied only for short time in small amounts (e.g., quick wiping to remove grease).	Avoid dipping or immersing in alcohol, gasoline, solvents etc.
TPO	Thermoplastic Olefine	80 (176)	Alcohol is harmless. Gasoline is harmless if applied only for short time in small amounts.	Most solvents are harmless but avoid dipping in gasoline, solvents, etc.
TPU	Thermoplastic Polyurethane	80 (176)	Alcohol is harmless if applied only for short time in small amounts (e.g., quick wiping to remove grease).	Avoid dipping or immersing in alcohol, gasoline, solvents, etc.
TSOP	TOYOTA Super Olefine Polymer	80 (176)	Alcohol and gasoline are harmless.	Most solvents are harmless.
UP	Unsaturated Polyester	110 (233)	Alcohol and gasoline are harmless.	Avoid alkali.

*Temperatures higher than those listed here may result in material deformation during repair.

3. LOCATION OF PLASTIC BODY PARTS

Parts Name	Code
Radiator Grille	TSOP
Front Bumper Cover	TSOP
Headlight	PP/PC
Front Foglight	PC
Side Turn Signal Light	ABS/PMMA
Outer Rear View Mirror	ABS
Door Outside Handle	PC/PBT
Window Frame Moulding	ASA
Rear Door Rear Guide Seal	AES
Side Mudguard	TSOP
Rear Spoiler	ABS
High Mount Stop Light	ABS/PMMA
Back Door Outside Garnish	ABS
Rear Combination Light	ASA/PMMA
Rear Bumper Cover	TSOP
Rear No.1 Spoiler	PP/EPDM
Rear Side Spoiler	PP/EPDM
License Plate Light	PC

- Resin material differs with model.
- / Made up of 2 or more kinds of materials.

HOW TO USE THIS MANUAL

1. BODY PANEL REPLACEMENT THIS MANUAL

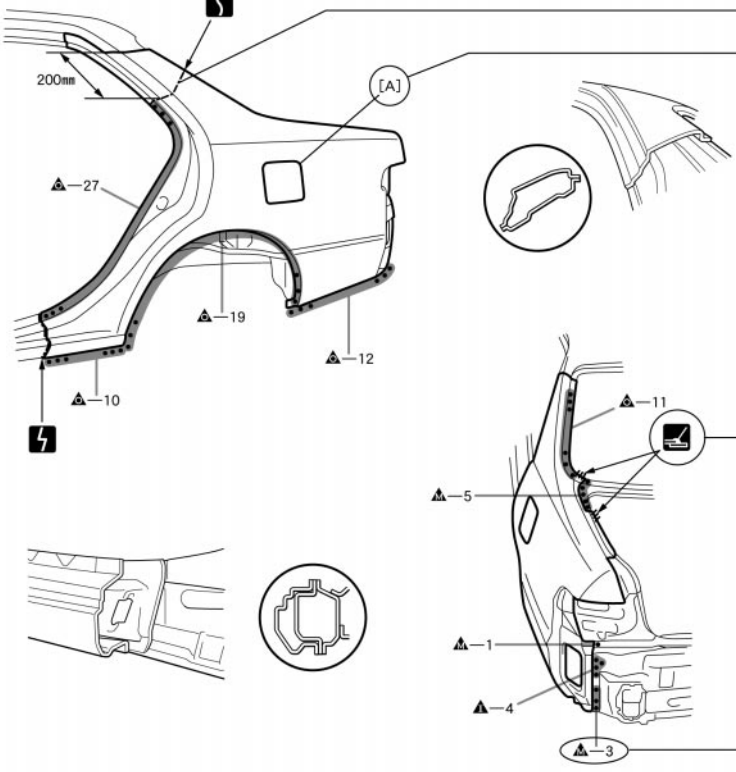
BP-34	BODY PANEL REPLACEMENT
<p>(A) QUARTER PANEL (CUT) REPLACEMENT</p>	
<p>(B) REMOVAL</p>	<p>(I)</p> <p>(K)</p>
<p>(D)</p>	
<p>(E)</p>	<p>(J)</p>
<p>POINT 1 Remove the [A] at the same time.</p> <p>PART NAME [A] Fuel Filler Opening Lid</p>	

(A) : REPLACEMENT PART AND METHOD
QUARTER PANEL (CUT)

Replacement method
 (ASSY) ... Assembly replacement
 (CUT) ... Major cutting (less than 1/2 of part used)
 (CUT-H) ... Half cutting (about 1/2 of part used)
 (CUT-P) ... Partial cutting (most of part used)

Replacement part

(B) : REMOVAL CONDITIONS

(C) : PART LOCATION

(D) : REMOVAL DIAGRAM
 Describes in detail removal of the damaged part involving repair by cutting.

(E) : REMOVAL GUIDE
 Provides additional information to more efficiently help you perform the removal.

BODY PANEL REPLACEMENT

BP-35

INSTALLATION

- Temporarily install the new parts and measure each part of the new parts in accordance with the body dimension diagram. (See the body dimension diagram)
- Inspect the fitting of the related parts around the new parts before welding. This affects the appearance of the finish.
- After welding, apply the polyurethane foam to the corresponding parts.
- After welding, apply body sealer and under-coating to the corresponding parts.
- After applying the top coat layer, apply anti-rust agent to the inside of the necked section structural weld spots.

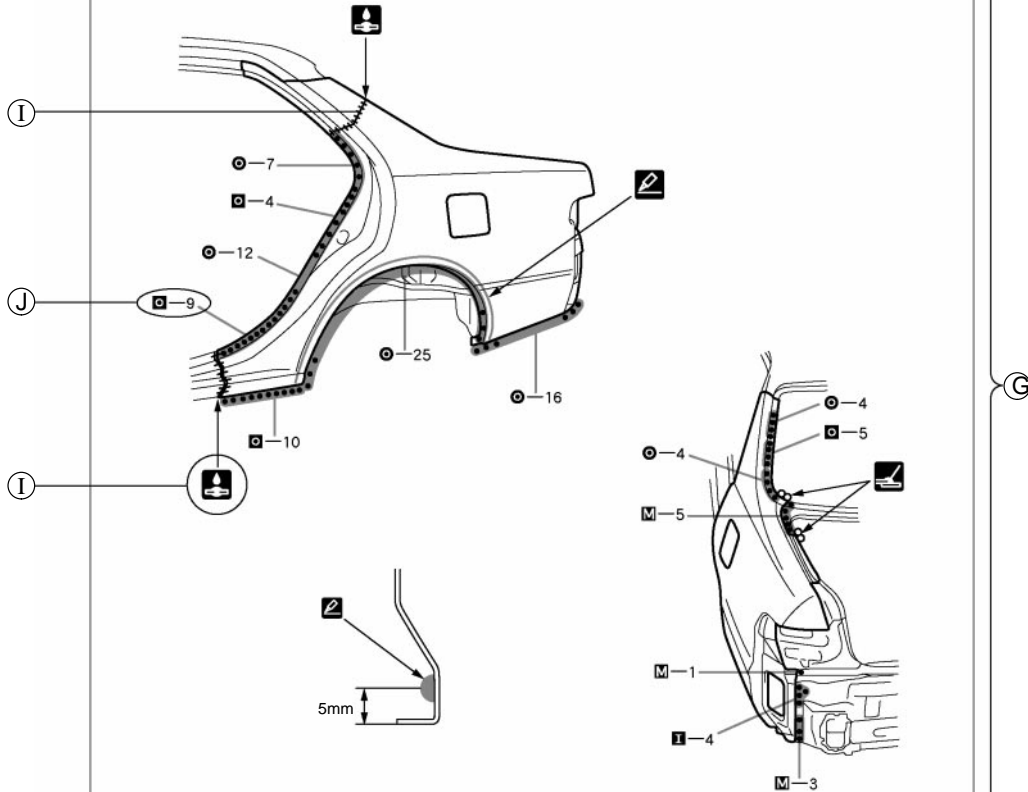

POINT

- 1 Before temporarily installing the new parts, apply body sealer to the wheel arch.
- HINT:*
- 1) Apply body sealer about 5mm (0.20in.) from the flange, avoiding any oozing.
 - 2) Apply sealer evenly, about 3 - 4mm (0.12 - 0.16in.) in diameter.
 - 3) For other sealing points, refer to section PC.

PART NAME

- [A] Fuel Filler Opening Lid [B] Waterproof Rivet

(F) : INSTALLATION CONDITIONS

(G) : INSTALLATION DIAGRAM
Describes in detail installation to the new part involving repair by welding and/or cutting, but excluding painting.

(H) : INSTALLATION GUIDE
Provides additional information to more efficiently help you perform the installation.













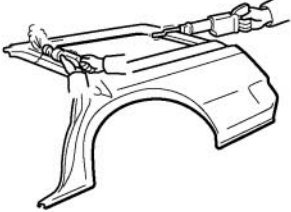





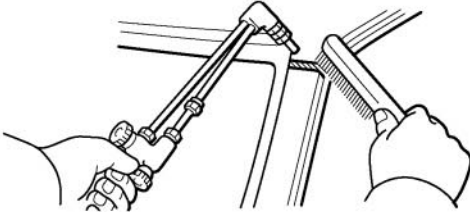

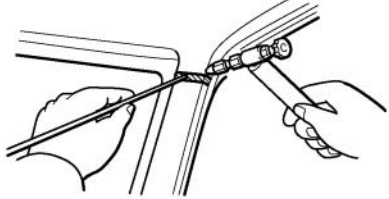
(I) : SYMBOLS
(See page IN-7)

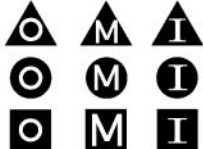
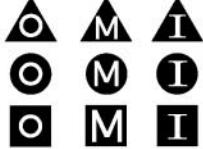

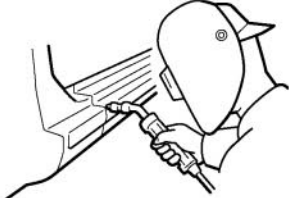
(J) : ILLUSTRATION OF WELD POINTS
Weld method and panel position symbols (See page IN-9)

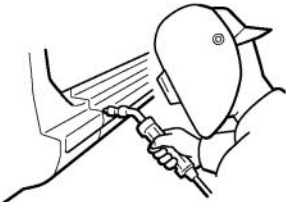
(K) : PART NAME

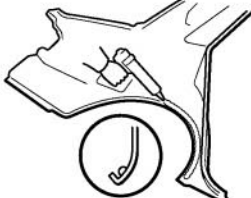
2. SYMBOLS

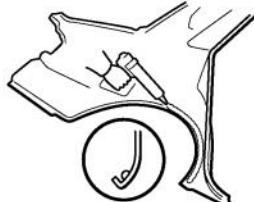
The following symbols are used in the welding diagrams in section BP of this manual to indicate cutting areas and the types of weld required.

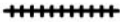
SYMBOLS		MEANING	ILLUSTRATION
		CUT AND JOIN LOCATION (SAW CUT)	 
		CUT AND JOIN LOCATION (Cut Location for Supply Parts)	
		CUT LOCATION	
		CUT WITH DISC SANDER, ETC.	
		BRAZE (Removal)	
		BRAZE (Installation)	
		WELD POINTS	
		SPOT WELD OR MIG PLUG WELD (See Page IN-9)	
		CONTINUOUS MIG WELD (BUTT WELD)	
		CONTINUOUS MIG WELD (TACK WELD)	
		BODY SEALER	

SYMBOLS		MEANING	ILLUSTRATION
—		Assembly Mark	
	—	BODY SEALER (Flat Finishing)	
—	—	BODY SEALER (No flat Finishing)	

3. ILLUSTRATION OF WELD POINT SYMBOLS

EXAMPLE:

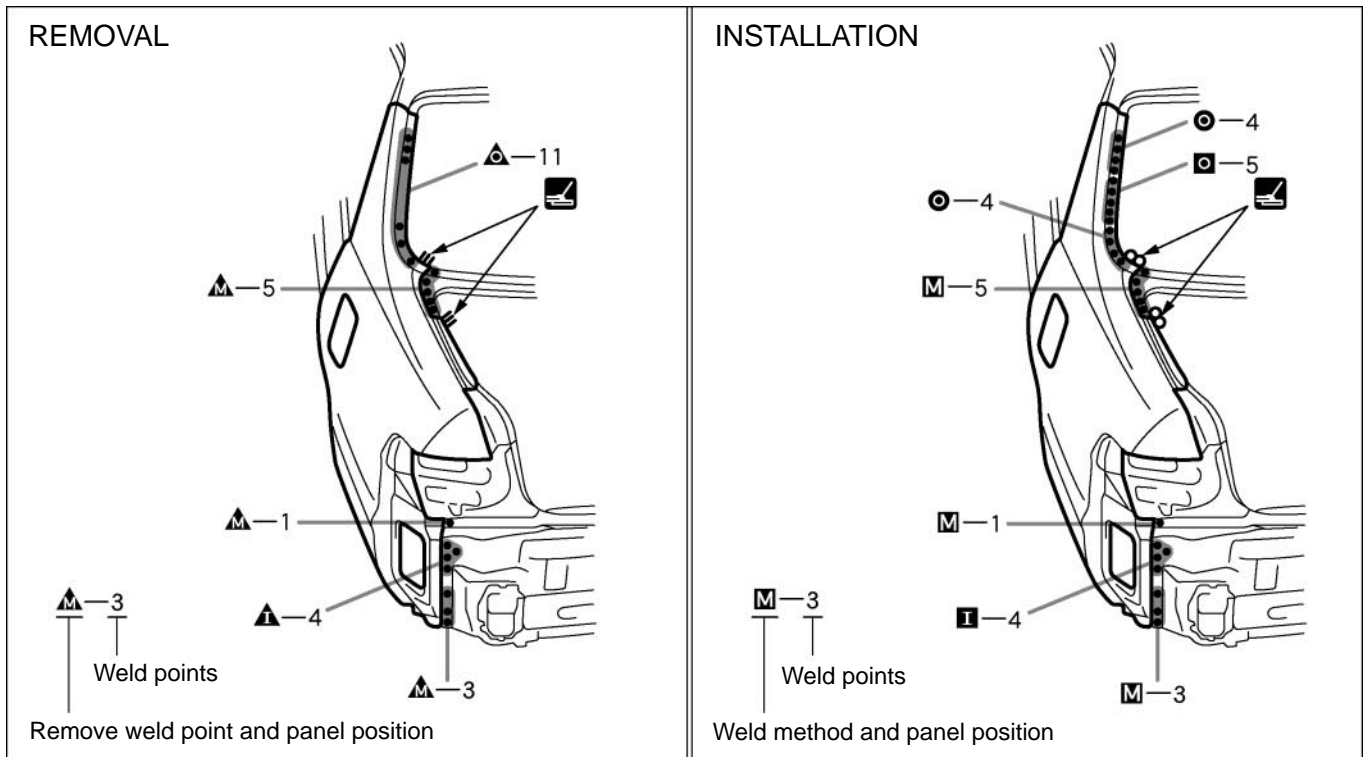

SYMBOLS	MEANING	ILLUSTRATION	SYMBOLS	MEANING	ILLUSTRATION
 	Remove Weld Points		 	Spot Weld	
	(Outside)		 	MIG Plug Weld	
	(Middle)		 	Spot MIG Weld	
	(Inside)			Spot MIG Weld	
<p><i>HINT: Panel position symbols are as seen from the working posture.</i></p>					

PROPER AND EFFICIENT WORK PROCEDURES

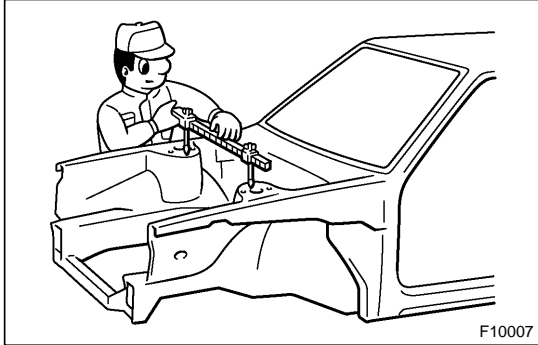

1. REMOVAL

(a) PRE-REMOVAL MEASURING

- (1) Before removal or cutting operations, take measurements in accordance with the dimension diagram. Always use a puller to straighten a damaged body or frame.

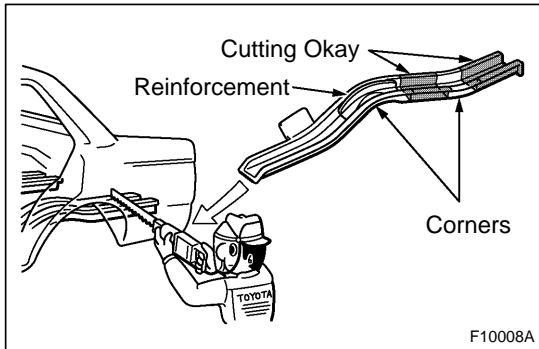

(b) CUTTING AREA

- (1) Always cut in a straight line and avoid reinforced area.

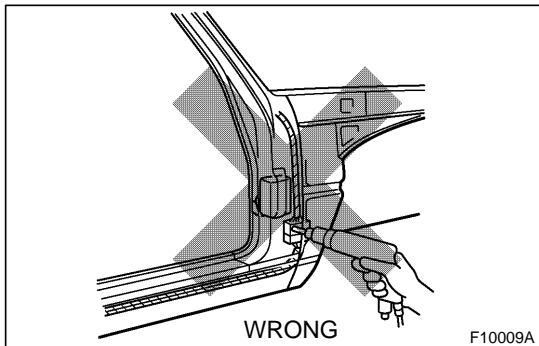

(c) PRECAUTIONS FOR DRILLING OR CUTTING

- (1) Check behind any area to be drilled or cut to insure that there are no hoses, wires, etc., that may be damaged.

HINT: See "Handling Precautions on Related Components" on page IN-15.

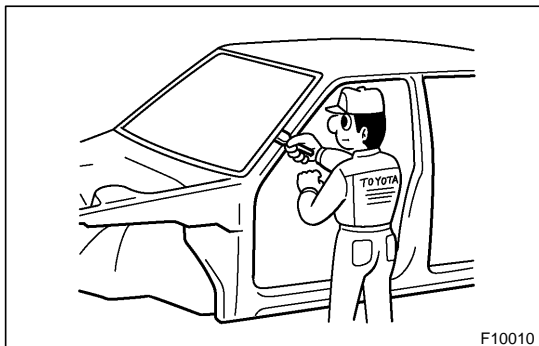

(d) REMOVAL OF ADJACENT COMPONENTS

- (1) When removing adjacent components, apply protective tape to the surrounding body and your tools to prevent damage.

HINT: See "Handling Precautions on Related Components" on page IN-15.

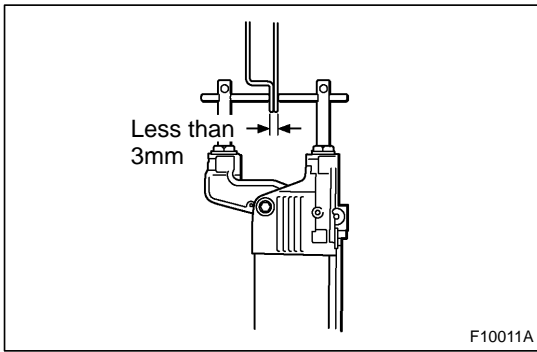

2. PREPARATION FOR INSTALLATION

(a) SPOT WELD POINTS

- (1) When welding panels with a combined thickness of over 3mm (0.12in.), use a MIG (Metal Inert Gas) welder for plug welding.

HINT: Spot welding will not provide sufficient durability for panels over 3mm (0.12in.) thick.

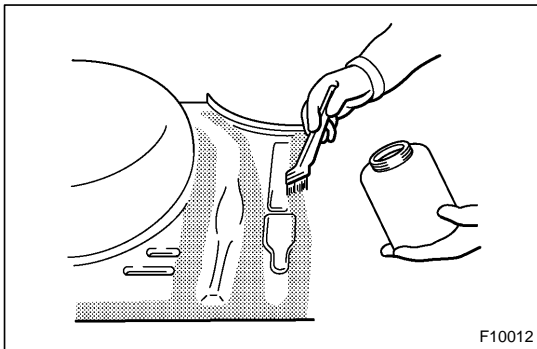

(b) APPLICATION OF WELD-THROUGH PRIMER (SPOT SEALER)

- (1) Remove the paint from the portion of the new parts and body to be welded, and apply weld-through primer.

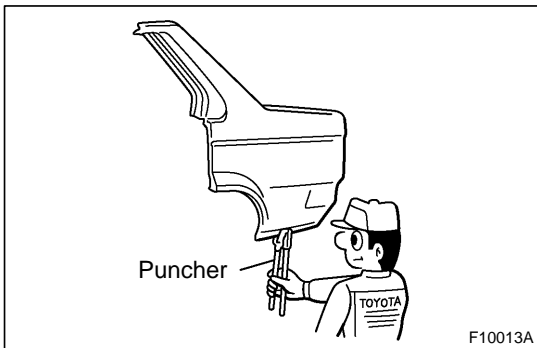

(c) MAKING HOLES FOR PLUG WELDING

- (1) For areas where a spot welder cannot be used, use a puncher or drill to make holes for plug welding.

REFERENCE:

mm (in.)

Thickness of welded portion	Size of plug hole
1.0 (0.04) under	5 (0.20) ϕ over
1.0 (0.04) - 1.5 (0.06)	6.4 (0.26) ϕ over
1.5 (0.06) over	8 (0.31) ϕ over

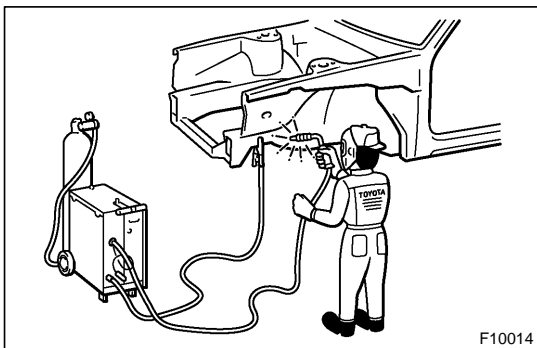

(d) SAFETY PRECAUTIONS FOR ELECTRICAL COMPONENTS

- (1) When welding, there is a danger that electrical components will be damaged by the electrical current flowing through the body.
- (2) Before starting work, disconnect the negative terminal of the battery and ground the welder near the welding location of the body.

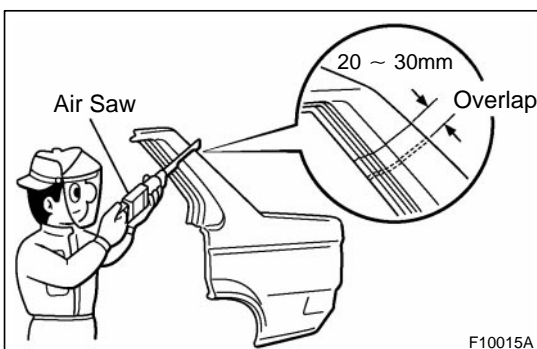

(e) ROUGH CUTTING OF JOINTS

- (1) For joint areas, rough cut the new parts, leaving 20 - 30mm (0.79 - 1.18in.) overlap.

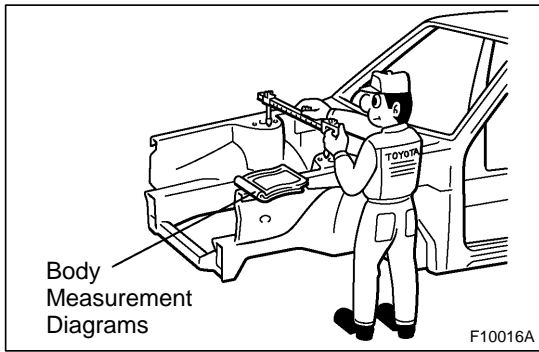

3. INSTALLATION

(a) PRE-WELDING MEASUREMENTS

- (1) Always take measurements before installing underbody or engine components to insure correct assembly. After installation, confirm proper fit.

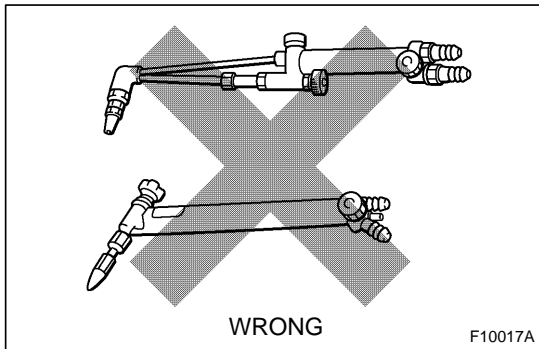

(b) WELDING PRECAUTIONS

- (1) The number of welding spots should be as follows.
Spot weld: 1.3 X No. of manufacturer's spots.
Plug weld: More than No. of manufacturer's plugs.
- (2) Plug welding should be done with a MIG (Metal Inert Gas) welder. Do not gas weld or braze panels at areas other than specified.

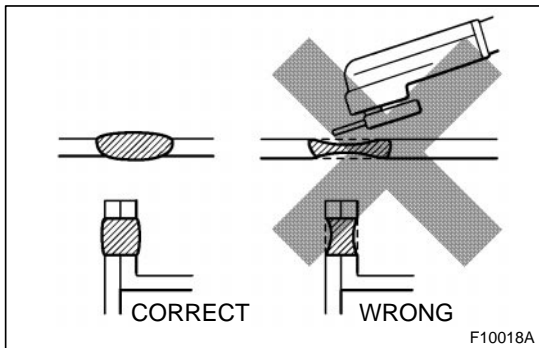

(c) POST-WELDING REFINISHING

- (1) Always check the welded spots to insure they are secure.
- (2) When smoothing out the weld spots with a disc grinder, be careful not to grind off too much as this would weaken the weld.

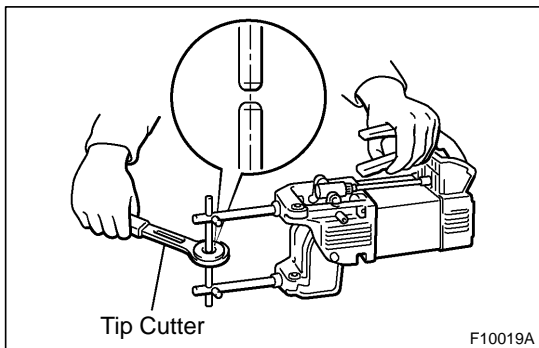

(d) SPOT WELD LOCATIONS

- (1) Try to avoid welding over previous spots.

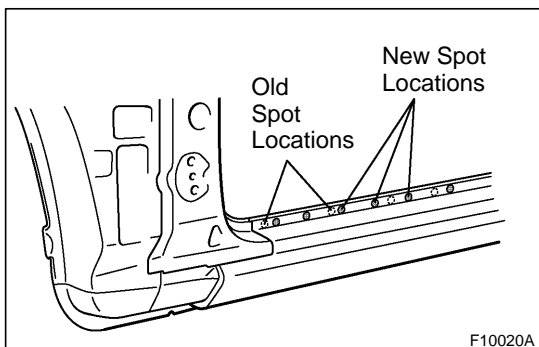

(e) SPOT WELDING PRECAUTIONS

- (1) The shape of the welding tip point has an effect on the strength of the weld.
- (2) Always insure that the seams and welding tip are free of paint.

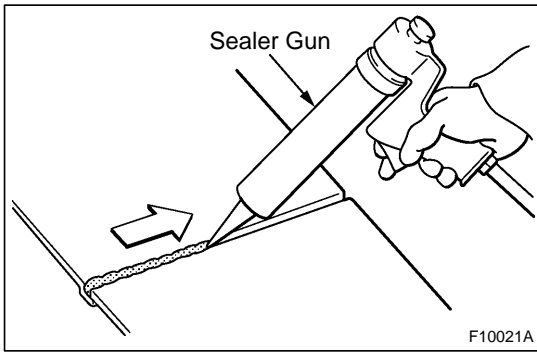

4. ANTI-RUST TREATMENT

(a) BODY SEALER APPLICATION

- (1) For water-proofing and anti-corrosion measures, always apply the body sealer to the body panel seams and hems of the doors, hoods, etc.

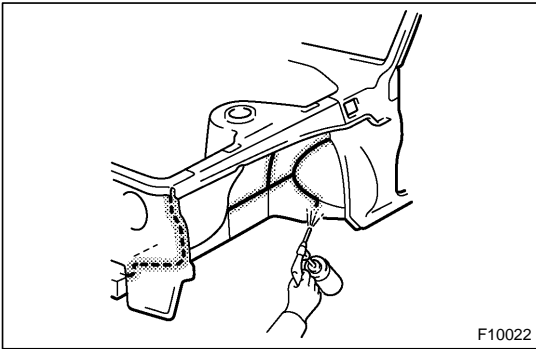

(b) UNDERCOAT APPLICATION

- (1) To prevent corrosion and protect the body from damage by flying stones, always apply sufficient undercoat to the bottom surface of the under body and inside of the wheel housings.

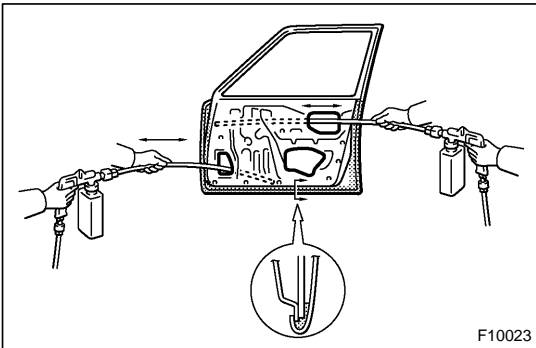

5. ANTI-RUST TREATMENT AFTER PAINTING PROCESS

(a) ANTI-RUST AGENT (WAX) APPLICATION

- (1) To preserve impossible to paint areas from corrosion, always apply sufficient anti-rust agent (wax) to the inside of the hemming areas of the doors and hoods, and around the hinges, or the welded surfaces inside the boxed cross-section structure of the side member, body pillar, etc.

6. ANTI-RUST TREATMENT BY PAINTING

REFERENCE:

Painting prevents corrosion and protect the sheet metal from damage. In this section, anti-chipping paint only for anti-corrosion purpose is described.

(a) ANTI-CHIPPING PAINT

- (1) To prevent corrosion and protect the body from damage by flying stones, etc., apply anti-chipping paint to the rocker panel, wheel arch areas, balance panel, etc.

HINT:

Depending on the model or the application area, there are cases where the application of anti-chipping paint is necessary before the second coat or after the top coat.

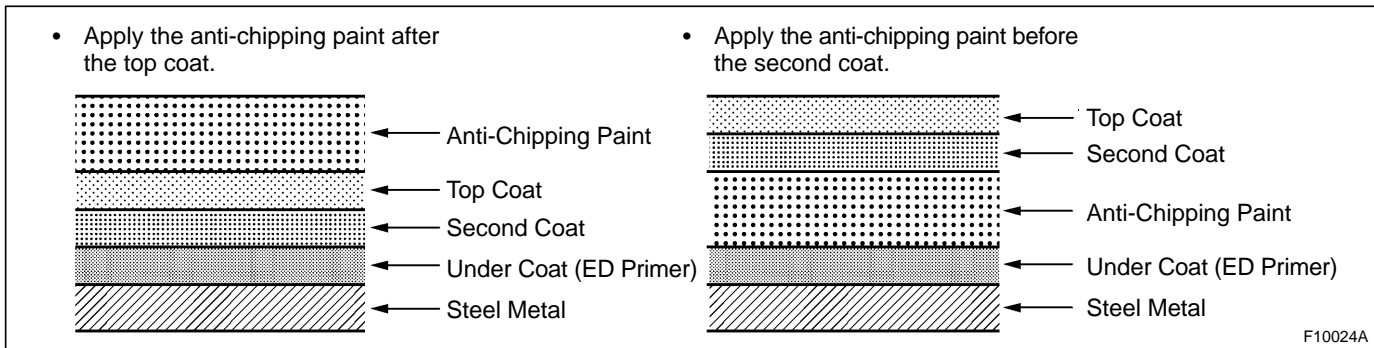

HANDLING PRECAUTIONS ON RELATED COMPONENTS

1. BRAKE SYSTEM

The brake system is one of the most important safety components. Always follow the directions and notes given in brake (32) of the repair manual for the relevant model when handling brake system parts.

NOTICE: When repairing the brake master cylinder or TRAC system, bleed the air out of the TRAC system.

2. DRIVE TRAIN AND CHASSIS

The drive train and chassis are components that can have great effects on the running performance and vibration resistance of the vehicle. After installing components in the sections listed in the table below, perform alignments to ensure correct mounting angles and dimensions. Particularly accurate repair of the body must also be done to ensure correct alignment.

HINT: Correct procedures and special tools are required for alignment. Always follow the directions given in the repair manual for the relevant model during alignment and section DI of this section.

Component to be aligned	Section of repair manual for relevant model
Front Wheels	Front Suspension (26) section
Rear Wheels	Rear Suspension (27) section

3. COMPONENTS ADJACENT TO THE BODY PANELS

Various types of component parts are mounted directly on or adjacently to the body panels. Strictly observe the following precautions to prevent damaging these components and the body panels during handling.

- Before repairing the body panels, remove their components or apply protective covers over the components.
- Before prying components off using a screwdriver or a scraper, etc., attach protective tape to the tool tip or blade to prevent damaging the components and the body paint.
- Before removing components from the outer surface of the body, attach protective tape to the body to ensure no damage to painted areas.

HINT: Apply touch-up paint to any damaged paint surfaces.

- Before drilling or cutting sections, make sure that there are no wires, etc. on the reverse side.

4. ECU (ELECTRONIC CONTROL UNIT)

Many ECUs are mounted in this vehicle.

Take the following precautions during body repair to prevent damage to the ECUs.

- Before starting electric welding operations, disconnect the negative (-) terminal cable from the battery.

When the negative (-) terminal cable is disconnected from the battery, memory of the clock and audio systems will be cancelled. So before starting work, make a record of the contents memorized by each memory system. Then when work is finished, reset the clock and audio systems as before.

When the vehicle has tilt and telescopic steering, power seat and outside rear view mirror, which are all equipped with memory function, it is not possible to make a record of the memory contents.

So when the operation is finished, it will be necessary to explain this fact to the customer, and request the customer to adjust the features and reset the memory.

- Do not expose the ECUs to ambient temperatures above 80°C (176°F).

NOTICE: If it is possible the ambient temperature may reach 80°C (176°F) or more, remove the ECUs from the vehicle before starting work.

- Be careful not to drop the ECUs and not to apply physical shocks to them.

PRECAUTIONS FOR REPAIRING BODY STRUCTURE PANELS

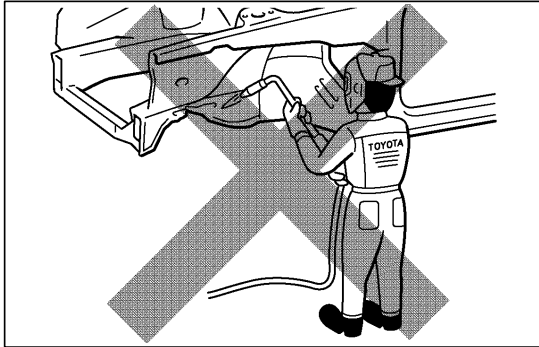

1. HEAT REPAIR FOR BODY STRUCTURE PANELS

Toyota prohibits the use of the heat repair method on body structure panels when repairing a vehicle damaged in a collision.

Panels that have high strength and rigidity, as well as a long life span for the automobile body are being sought after.

At Toyota, in order to fulfill these requirements, we use high tensile strength steel sheets and rust preventive steel sheets on the body.

High tensile steel sheets are made with alloy additives and a special heat treatment in order to improve the strength.

To prevent the occurrence of rust for a long period of time, the surface of the steel is coated with a zinc alloy.

If a body structure part is heat repaired with an acetylene torch or other heating source, the crystalline organization of the steel sheet will change and the strength of the steel sheet will be reduced.

The ability of the body to resist rust is significantly lowered as well since the rust resistant zinc coating is destroyed by heat and the steel sheet surface is oxidized.

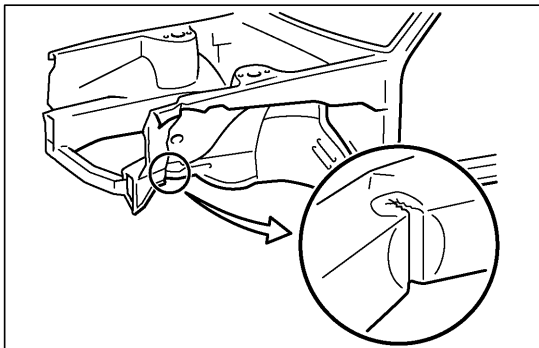

2. STRUCTURE PANEL KINKS

A sharp deformation angle on the panel that cannot be returned to its original shape by pulling or hammering is called a kink.

Since structure parts were designed to exhibit a 100% performance when they were in their original shape, if they are deformed in an accident, or if the deformed parts are repaired and reused, they become unable to exhibit the same performance as intended in the design.

It is necessary to replace the part where the kink has occurred.

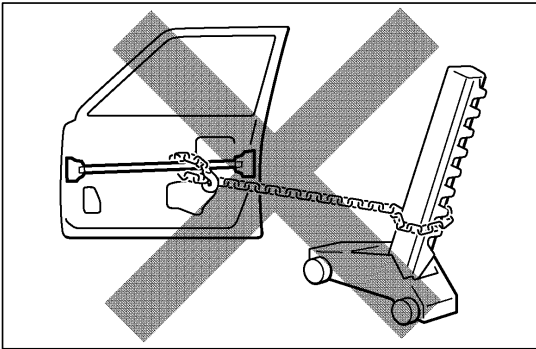
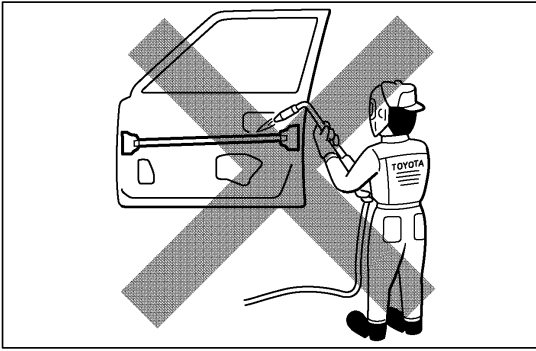

3. IMPACT BEAM REPAIR

The impact beam and bracket are necessary and important parts in maintaining a survival space for passengers in a side collision.

For impact beam, we use special high tensile strength steel.

The high tensile strength steel maintains its special crystal-line organization by heat treatment or alloy additives.

Since these parts were designed to exhibit a 100% performance when they were in their original shape, if they are deformed in an accident, or if the deformed parts are repaired and reused, they become unable to exhibit the same performance as intended in the design.

It is necessary to replace the door assembly when impact beam or bracket is damaged.

FOR ALL OF VEHICLES

PRECAUTION

1. PRECAUTIONS FOR HIGH-VOLTAGE CIRCUIT INSPECTION AND SERVICE

- (a) Engineer must undergo special training for high-voltage system inspection and servicing.
- (b) All high-voltage wire harness connectors are colored orange. The HV battery and other high-voltage components have "High Voltage" caution labels. Do not carelessly touch these wires and components.
- (c) Before inspecting or servicing the high-voltage system, be sure to follow safety measures, such as wearing insulated gloves and removing the service plug to prevent electrocution. Carry the removed service plug in your pocket to prevent other technicians from reinstalling it while you are servicing vehicle.

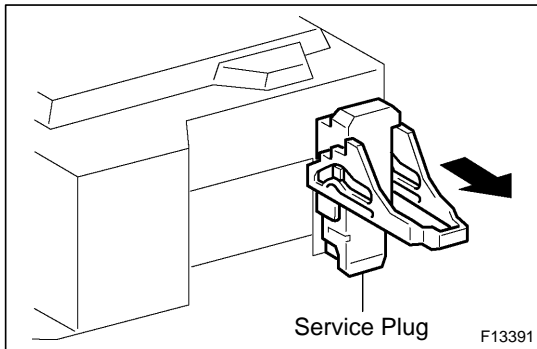

- (d) After removing the service plug, wait 5 minutes before touching any of the high-voltage connectors and terminals.

HINT:

5 minutes are required to discharge the high-voltage condenser inside the inverter.

- (e) Be sure install the service plug before starting the hybrid system. Starting the hybrid system with the service plug removed may damage the vehicle.

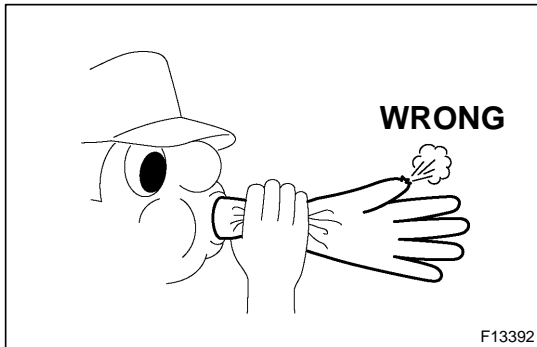

- (f) Before wearing insulated gloves, make sure that they are not cracked, ruptured, torn, or damaged in any way. Do not wear wet insulated gloves.

- (g) When servicing the vehicle, do not carry metal objects like mechanical pencils or scales that can be dropped accidentally and cause a short circuit.

- (h) Before touching a bare high-voltage terminal, wear insulated gloves and use an electrical tester to ensure that the terminal is not charged with electricity (approximately 0 V).

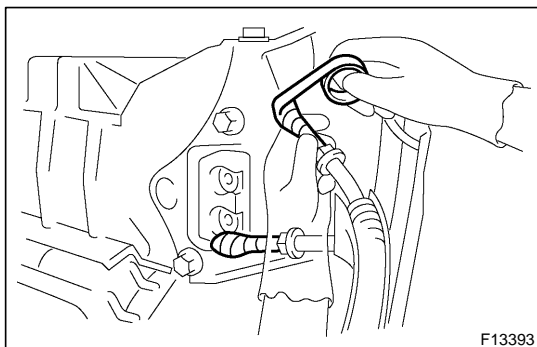

- (i) After disconnecting or exposing a high-voltage connector or terminal, insulate it immediately using insulation tape.

- (j) The screw of a high-voltage terminal should be tightened firmly to the specified torque. Both insufficient and excessive torque can cause failure.

- (k) Use the "CAUTION: HIGH VOLTAGE. DO NOT TOUCH DURING OPERATION" sign to notify other engineers that a high-voltage system is being inspected and/or repaired.

- (l) Do not place the battery upside down while removing and installing it.

- (m) After servicing the high-voltage system and before reinstalling the service plug, check again that you have not left a part or tool inside, that the high-voltage terminal screws are firmly tightened, and that the connectors are correctly connected.

Person in charge: _____

**CAUTION:
HIGH VOLTAGE. DO
NOT TOUCH DURING
OPERATION.**

**CAUTION:
HIGH VOLTAGE. DO
NOT TOUCH DURING
OPERATION.**

Person in charge: _____

Copy this page and put it after folding on the roof of the vehicle in service.

-
- 2. ACTIONS TO BE TAKEN FOR VEHICLE DAMAGED BY IMPACT**
- (a) Items to be prepared or operation at the site of the accident
- Protective clothing (insulated gloves, rubber gloves, goggles, and safety shoes)
 - Saturated boric acid solution 20 L (obtain 800 g of boric acid powder, put it into a container, and dissolve it in water)
 - Red litmus paper
 - ABC fire extinguisher (effective against both oil flames and electrical flames)
 - Shop rags (for wiping off the electrolyte)
 - Vinyl tape (for insulating cable)
 - Electrical tester
- (b) Actions to be taken at the place of accident
- (1) Wear insulated or rubber gloves, goggles and safety shoes.
 - (2) Do not touch a bare cable that could be a high voltage cable. If the cable must be touched or if accidental-contact is unavoidable, follow these instructions: 1) wear insulated or rubber gloves and goggles, 2) measure the voltage between the cable and the body ground using an electrical tester, and 3) insulate the cable using vinyl tape.
 - (3) If the vehicle catches fire, use an ABC fire extinguisher to extinguish the fire. Trying to extinguish a fire using only a small amount of water can be more dangerous than effective. Use a substantial amount of water or wait for firefighters.
 - (4) Check the HV battery and immediate area for any electrolyte leakage. Do not touch any leaked liquid because it could be highly alkaline electrolyte. Wear rubber gloves and goggles, and then apply red litmus paper to the leak. If the paper turns blue, the liquid must be neutralized before wiping. Neutralize the liquid using the following procedures:
 - 1) apply saturated boric acid solution to the liquid, and
 - 2) reapply red litmus paper and make sure it does not turn blue. Repeat steps 1 and 2 above until the paper does not turn blue. Then wipe the neutralized liquid with a shop rag.
 - (5) If a damage to any of the high-voltage components and cables is suspended, cut the high-voltage circuit using the procedure on the following pages.

High-voltage part and Wiring

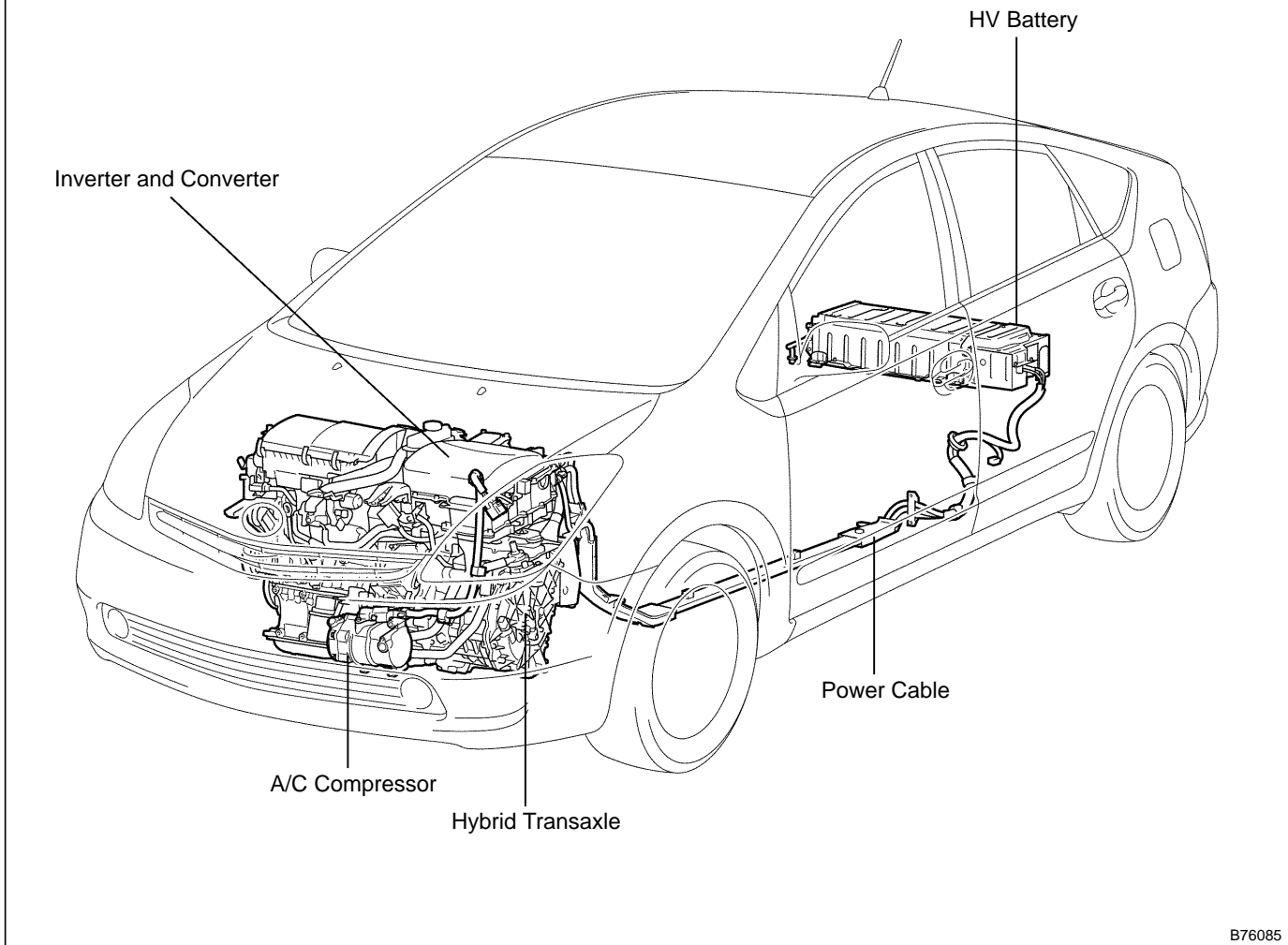

B76085

- Push the shift switch to the P position and engage the parking brake.
- Remove the key from the key slot. Then disconnect the power cable from the negative (-) terminal of the auxiliary battery.
- Remove the service plug while wearing insulated gloves. If the service plug cannot be removed due to damage to the rear portion of the vehicle, remove the HV fuse instead.
- Do not turn the power switch on while removing the service plug.

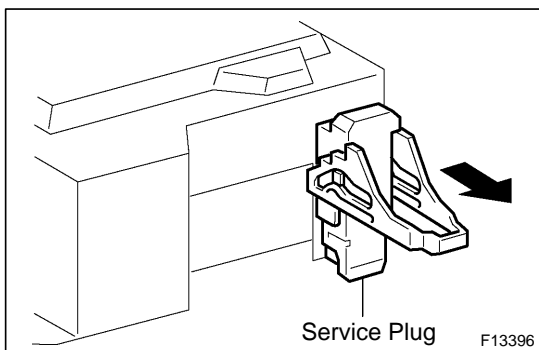

Service Plug

F13396

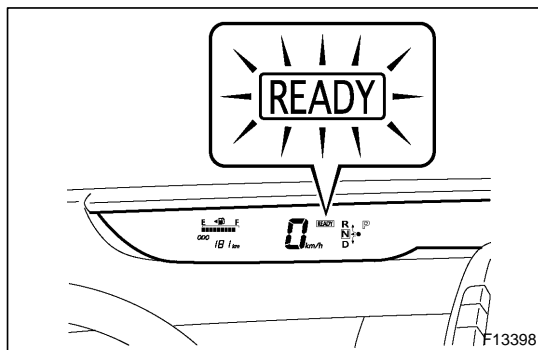
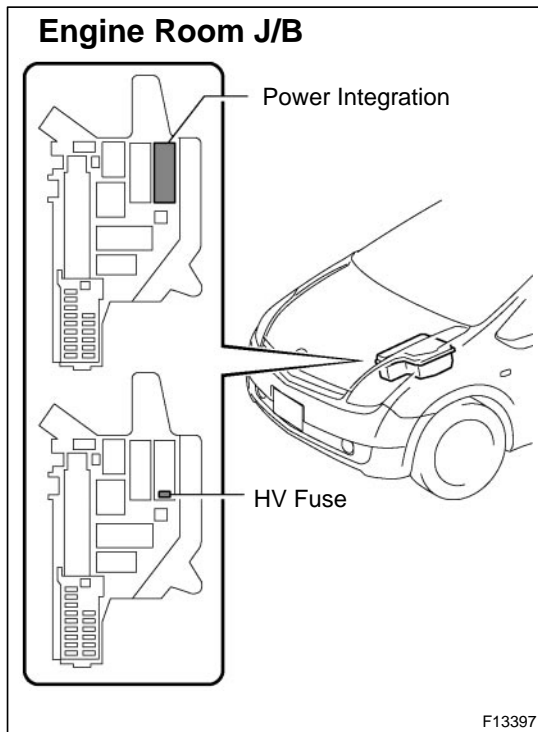

If the service plug cannot be removed due to damage to the rear portion of the vehicle, remove the HV fuse instead.

(c) Moving the damaged vehicle

HINT:

If any of the following applies, tow the vehicle away using a tow truck.

- One or more of the high-voltage components and cables are damaged.
- The driving, traction, or fuel system is damaged.

- The READY lamp is not illuminated when you turn.

NOTICE:

- **Before towing the vehicle away using a tow truck, disconnect the cable from the negative (-) terminal of the auxiliary battery and remove the service plug.**

Only if none of the above applies and there are no problems that might affect driving, drive the vehicle away from the place of accident to a safe, nearby place.

- **Perform the procedure below if the READY lamp turns off, or there are abnormal noises, unusual smells, or strong vibrations while driving:**
 - (1) Park the vehicle in a safe place.
 - (2) Push the selector lever to the P position and engage the parking brake.
 - (3) Disconnect the power cable from the negative (-) terminal of the auxiliary battery.
 - (4) Remove the service plug while wearing insulated gloves.

(d) Actions required after moving the damaged vehicle

If you see any liquid on the road surface, it could be highly alkaline electrolyte leakage.

Wear rubber gloves and goggles, and apply red litmus paper to the leak. If the paper turns blue, the liquid must be neutralized before wiping. Neutralize the liquid using the following procedures: 1) apply saturated boric acid solution to the liquid, and 2) reapply red litmus paper and make sure it does not turn blue. Repeat steps 1 and 2 above until the paper does not turn blue. Then wipe the neutralized liquid with a shop rag.

- (e) Items to be prepared (when repairing damaged vehicles)
 - Protective clothing (Insulated gloves, rubber gloves, goggles, and safety shoes)
 - Saturated boric acid solution 20 L (obtain 800 g of boric acid powder, put it into a container, and dissolve it in water)
 - Red litmus paper
 - Shop rags (for wiping off the electrolyte)
 - Vinyl tape (for insulating cable)
 - Electrical tester
- (f) Precautions to be observed when servicing the damaged vehicle:
 - (1) Wear insulated or rubber gloves, goggles, and safety shoes.
 - (2) Do not touch a bare cable that could be a high voltage cable. If the cable must be touched or if accidental contact is unavoidable, follow these instructions: 1) wear insulated or rubber gloves and goggles, 2) measure the voltage between the cable and the body ground using an electrical tester, and 3) insulate the cable using vinyl tape.
 - (3) Check the HV battery and immediate area for any electrolyte leakage. Do not touch any leaked liquid because it could be highly alkaline electrolyte. Wear rubber gloves and goggles, and then apply red litmus paper to the leak. If the paper turns blue, the liquid must be neutralized before wiping. Neutralize the liquid using the following procedures:
 - 1) apply saturated boric acid solution to the liquid, and
 - 2) reapply red litmus paper and make sure it does not turn blue. Repeat steps 1 and 2 above until the paper does not turn blue, Then wipe the neutralized liquid with a shop rag.
 - (4) If the electrolyte adheres to your skin, wash the skin immediately using saturated boric acid solution or a large amount of water. If the electrolyte adheres to an article of clothing, take it off immediately.
 - (5) If the electrolyte comes in contact with your eyes, call out loudly for help. Do not rub your eyes. Wash them with the large amount of water and seek medical care.
 - (6) If damage to any of the high-voltage components and cables is suspected, cut the high-voltage circuit using the procedure below.
 - Push the selector lever to the P position and engage the parking brake.
 - Remove the key from the key slot. Then disconnect the power cable from the negative (-) terminal of the auxiliary battery.

- Wear insulated gloves, and then remove the service plug.
 - If you cannot remove the service plug due to damage to the rear portion of the vehicle, remove the HV fuse or IGCT relay instead.
- (g) Precautions to be taken when disposing of the vehicle
When scrapping the vehicle, remove the HV battery from the vehicle and return it to the location specified by the manufacturer. The same applies to any damaged HV battery.
- (h) After removing the battery, keep it away from water. Water may heat the battery, which results in fire.
- (i) Precautions to be observed when towing
Tow the damaged vehicle with its front wheels or its front and rear wheels lifted off the ground.

NOTICE:

Towing the damaged vehicle with its front wheels on the ground may cause the motor to generate electricity. This electricity could, depending on the nature of the damage, leak and cause a fire.

- (j) Towing with 4 wheels on the ground

NOTICE:

- **If the damaged vehicle needs to be towed using a rope, do not exceed 30 km/h and tow only for very short distances. For example, towing from the accident site to a nearby tow truck is permissible.**
- **Set the power switch on and selector lever to the N position.**
- **If any abnormality is present in the damaged vehicle during the towing, stop towing immediately.**

- (k) Towing eyelet

- (1) Install the hook.
- (2) Hook a rope on to the illustrated area for towing.

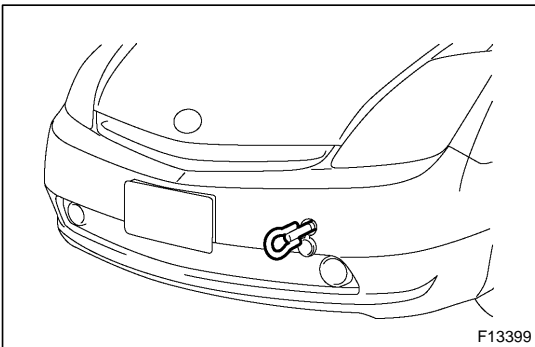

F13399

ABBREVIATIONS USED IN THIS MANUAL

For convenience, the following abbreviations are used in this manual.

ABS	Antilock Brake System
A/C	Air Conditioner
assy	assembly
ECT	Electronic Controlled Transmission
ECU	Electronic Control Unit
e.g.	Exempli Gratia (for Example)
Ex.	Except
FWD	Front Wheel Drive Vehicles
2WD	Two Wheel Drive Vehicles
4WD	Four Wheel Drive Vehicles
in.	inch
LH	Left-hand
LHD	Left-hand Drive
MIG	Metal Inert Gas
M/Y	Model Year
PPS	Progressive Power Steering
RH	Right-hand
RHD	Right-hand Drive
SRS	Supplemental Restraint System
SSM	Special Service Materials
w/	with
w/o	without