

## **Installing Fender-Mounted Turn-Signal Repeater Lights on a 2004-2005 Toyota Prius**

The Europe and Japan Prius' have fender-mounted turn-signal repeaters lights, but the North American Prius' do not. Evaluating the sight lines of the car, these lights would be a very useful safety addition to the car as other drivers cannot see the existing turn-signals unless they are literally behind the car.

Evaluating photos of an England/U.K. Prius, the light unit is a water-clear reflector type housing, with an amber colored bulb.



***U.K. Prius with turn-signal repeater lights***

While trying to figure out how to order these “Prius” parts from Japan, I noticed a Scion xB in a parking lot with familiar looking fender-mounted turn-signal repeaters lights! The Prius lights are the same units as used in the Scion xA and xB. The web site [www.scionlife.com](http://www.scionlife.com) yielded the part numbers for the lens unit, bulb, and socket (see illustration below).

FIG. 81-06 SIDE TURN SIGNAL LAMP

115410H-00213

2M7

PROB. DATE	MODELS	DESCRIPTION	R/P	PART NUMBER	REV-REF		
					QTY.	F	T
S 0304-	NCP31	81730B BULB (FOR SIDE TURN SIGNAL LAMP)		90981-15012-	2		
		12V 5W					
S 0304-	NCP51	81731 LENS, SIDE TURN SIGNAL LAMP, RH		81731-51020-	1		
S 0304-	NCP31	81735 SOCKET AND WIRE, SIDE TURN SIGNAL LAMP		90075-60005-	2		
S 0304-	NCP31	81741 LENS, SIDE TURN SIGNAL LAMP, LH		81731-51020-	1		

81261B

**The Scion xB part numbers**

Referencing the Prius wiring diagram, and looking at my own Prius, I selected some 20 AWG stranded wire (in yellow, green, and white to complement the Prius' existing yellow, green, and white with black striped wires). I chose a high temperature (125° C), thin insulated, PVC insulated wire that passed the UL flame test. I also selected some 3/4" and 1/4" heat-shrink tubing (black) to make the installation look clean, and to further protect the wires.

After picking up the lens unit, bulb, and socket from my local Toyota Dealer Parts counter; I carefully measured the flat-blade male connectors in the socket (as I could not order from Toyota the matching plug & wiring harness for this socket, I had to make my own wiring harness). Based on this measurement (the flat blades are approximately 0.020" x 0.085"), I selected some crimp-on, flat, female, 0.020" x 0.110", insulated connectors.

### Parts and Materials Required

Toyota	Lens Unit	81731-51021	\$29.73 each (x2)
Toyota	Socket	90075-60005	\$11.52 each (x2)
Toyota	Bulb	90981-15012	\$9.39 each (x2)
Toyota	Touch up paint that matches your Prius		\$8.89

Instead of the Toyota bulb, go to your local auto parts store for

Sylvania/Osram	Bulb	Part #2827	\$2.19 for two
or			
Sylvania/Osram	Bulb	Part #WY5W	\$2.19 for two

Digikey.com	Yellow Wire	C2040Y-100-ND	\$15.11 for 100 ft.
Digikey.com	Green Wire	C2040G-100-ND	\$15.11 for 100 ft.
Digikey.com	White Wire	C2040W-100-ND	\$15.11 for 100 ft.
Digikey.com	Female Crimp-on	A27797-ND	\$1.87 for ten
Digikey.com	3/4" Black Heatshrink	A034B-4-ND	\$1.89 for 4 ft.
Digikey.com	1/4" Black Heatshrink	A014B-4-ND	\$1.00 for 4 ft. (x2)

Home Depot	5 minute epoxy		about \$3.00
Home Depot	2" wide Blue, easy release masking tape		about \$5.00
Home Depot	Bare metal primer		about \$5.00
Home Depot	Artists (tiny) paint brushes		about \$2.00

### Tools and Other

Spool of thread  
Black electrical tape  
Soldering iron and solder  
Cloth measuring tape (from a sewing kit) with the metal ends taped-up  
Drill motor and drill bits  
Wire cutter  
Crimping tool for insulated connectors  
Heat gun or very hot blow-drier (to shrink the heat-shrink tubing)  
Small black wire-ties  
Small hand file (rounded profile)  
Very sharp hobby knife (X-Axto type)  
Dremel Moto-tool (or equivalent) with sanding drums  
Sheet metal hand-nibbler (like a *Klein* #76011B)  
Screwdrivers  
Cardboard or newspaper  
Two jack-stands  
Wheel chocks  
Your Prius' jack



### Instructions

1. Mask off the entire area where the lights will be mounted with the blue (easy-release) masking tape.
2. Using the lines in the above photo as a reference, stretch threads across the car and tape in place. These thread lines will mark where the Lens Unit will be mounted.
3. Remember, it does not matter if you position the lights exactly as in the photo, an  $\pm 1/8$ " accuracy is acceptable. *Your most important goal is to make both sides of your car identical, both in position and rotation.* So, use the cloth measuring tape to measure from key points on the car to make both locations identical.
4. Cut-out the template below, and trace the hole to transfer the cut-out to the masking tape. If the 1 inch square below is not EXACTLY 1 inches square, the template printed the wrong size!

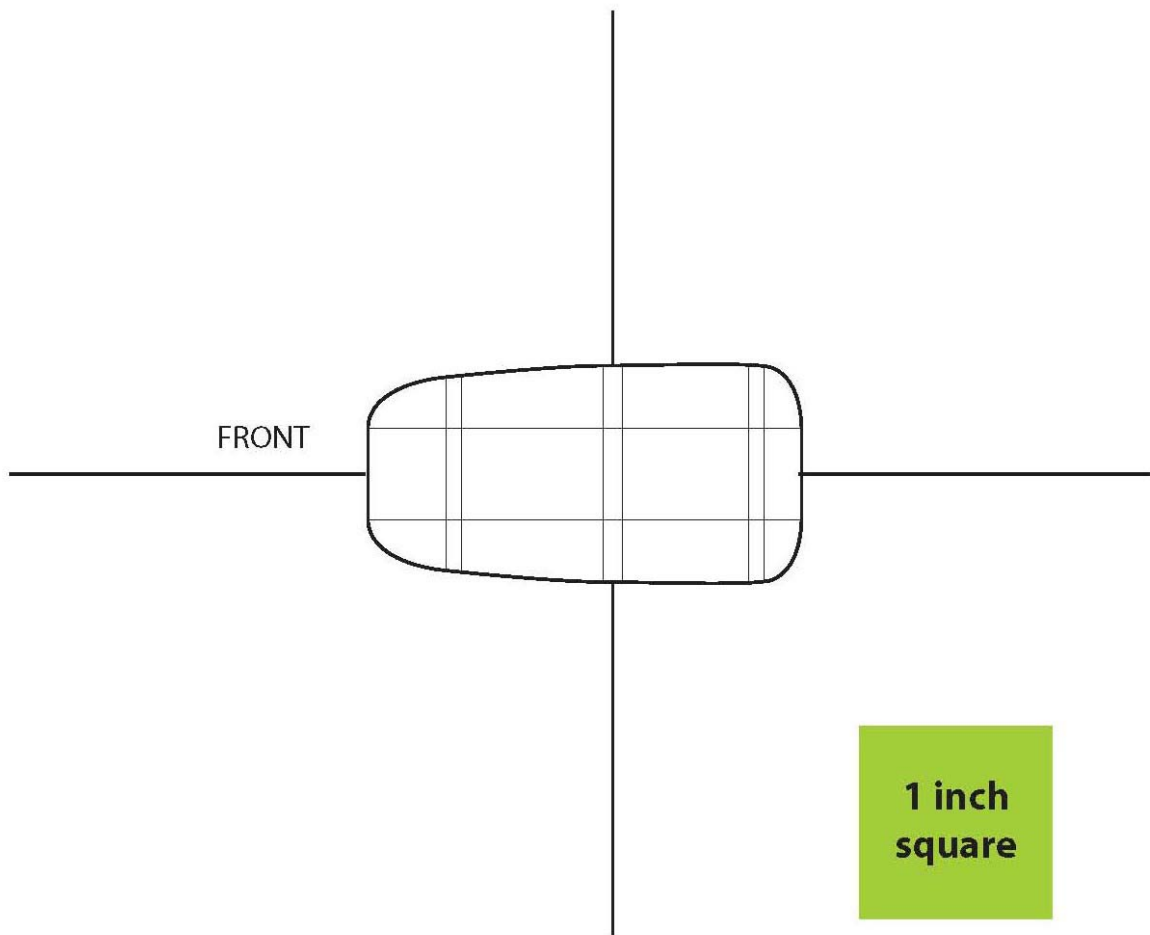

5. Set the emergency brake. Chock both the rear wheels before you jack up the front of the Prius. Put the front end of the car on jack-stands (do not depend on the wimpy Prius jack to hold the car in the air while you work on it).
6. Remove both front wheels.
7. Unclip the fender liners about 2/3 of the way to the front, and tape or secure into place. This provides full access to the backside of the fender.

8. Tape a sheet of newspaper inside the fender to catch or redirect the metal chips you soon will be making. Do not simply let the metal chips fall inside the fender, as they will rust.
9. By slowly stepping up drill sizes, drill a hole large enough to accept the hand nibbler tool. Take small bites with the hand nibbler without causing any distortion of the fender. Nibble up to 1/32" – 1/16" of the outline of the hole.
10. Use the Moto-Tool with sanding cylinders to bring the hole to its proper dimensions. Check the fit with the Lens Unit itself.
11. Use the small hand file to round-off and smooth the rough edges.
12. When you are satisfied with the hole, peel off the masking tape. Re-apply new masking tape about 1/32" beyond the edge of the hole. Paint on the metal primer (inside surfaces too), and allow to dry overnight. Paint on the matching paint (inside surfaces too), and allow to dry overnight.
13. Construct the wiring harnesses. Cut two 36" pieces of white wire, cut one 36" piece of yellow wire, and cut one 36" piece of green wire. At one end of each wire, crimp-on a female connector.
14. Insert the female connectors in the sockets (green & white wires are for the right turn signal, yellow & white wires are for the right turn signal). As this is powering a light bulb, polarity does not matter. Pot the connectors into the sockets with the 5-minute epoxy.
15. After the epoxy is set, slip a 2" long piece of 3/4" heat-shrink tubing over the wires and over base of socket. Shrink into place. Slip a 30" long piece of 1/4" heat-shrink tubing over the wires and over the just-shrunk 3/4" tubing. Shrink the entire 30" piece of tubing.
16. Pass the wire end of each harness through your newly created fender hole, up to the top of the fender, and into the engine compartment near the existing turn signal. Securely tape the socket to the outside of the fender, with about 2" of wire outside the hole.
17. Reinstall the fender liners. Reinstall both front wheels. Put Prius back on all 4 tires. Follow the wheel bolt torque instructions in the owner's manual.
18. In the engine compartment, anchor the wire harness to one of the holes in the fender with a wire tie.
19. Look carefully at the back of the existing turn-signal sockets. The wires are covered with a black plastic similar to electrical tape. Use the hobby knife to CAREFULLY cut the black plastic so you can peel it away to expose the wires.
20. CAREFULLY cut a small (1/4" long) section out of each existing turn-signal wire, without damaging the wire underneath. Confirm your wire harness routing before cutting it to length. Make a small loop in the end of each wire harness wire, and twist onto the exposed section of the existing turn-signal wire to make a solid mechanical connection before soldering. Remember: soldering is not welding; solder does *not* make a good mechanical connection.
21. After soldering each connection, tape with the black electrical tape, and secure the electrical tape (from unraveling in the engine compartment heat) with a small wire tie.

# Turn Signal and Hazard Warning Light

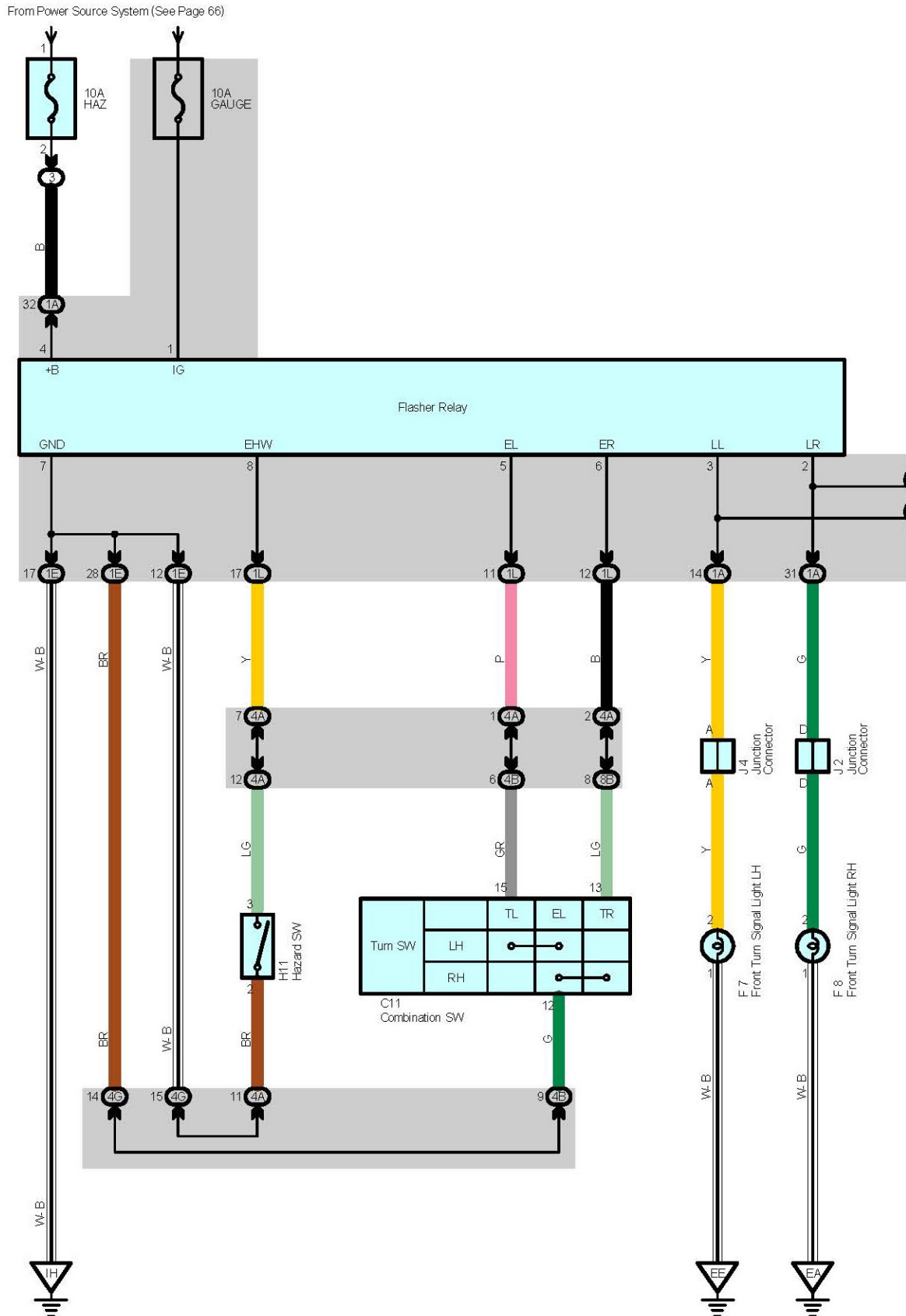



22. Install the bulbs in the socket, secure the socket to the Lens Unit, and snap the assembly into place.

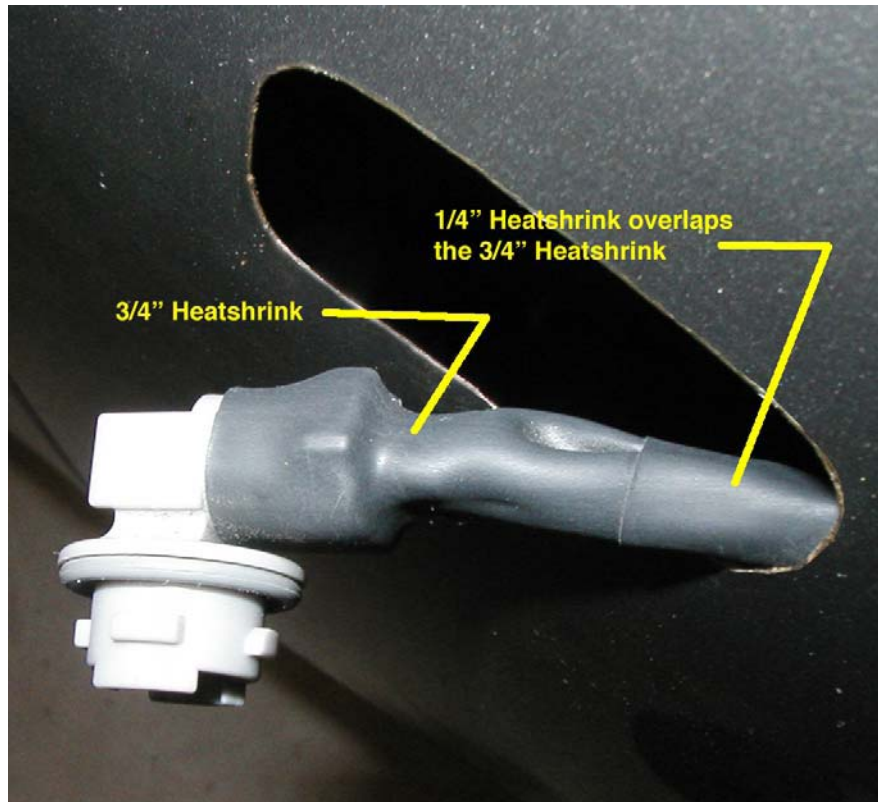





Standard Disclaimer that seems to always be a part of these types of documents:

This modification is undertaken at your own risk. It could result in damage to your vehicle. You could be injured doing the modification. Neither the author, nor anyone distributing this document will be held responsible for injuries or damage or financial loss resulting from any of the modifications. You should not make this modification unless you are mechanically and electrically competent. There is no guarantee that the information contained here is accurate.

Don't get too angry at the author if you don't like this document or disagree with its contents. After all, the author spent many hours researching, compiling the documents contents, and creating this document; but has charged you nothing for this hard-earned knowledge.

This document may be freely shared and distributed

Version 1.0, June 8, 2005