

LUBRICATION SYSTEM

ON-VEHICLE INSPECTION

1. CHECK ENGINE OIL LEVEL

- (a) Warm up the engine, then stop the engine and wait for 5 minutes. Check that the engine oil level is between the low and full marks on the oil level gauge.

If the engine oil is low, check for oil leaks and add engine oil up to the full mark.

NOTICE:

Do not add engine oil above the full mark.

2. CHECK ENGINE OIL QUALITY

- (a) Check the oil for deterioration, water intrusion, discoloring or thinning.

If the oil quality is visibly poor, replace the oil.

Oil grade:

Use API grade SL "Energy-Conserving", or ILSAC multi grade engine oil.

SAE 5W-30 is the best choice for good fuel economy and good starting in cold weather.

If SAE 5W-30 is not available, SAE 10W-30 may be used.

However, it should be replaced with SAE 5W-30 at the next oil replacement.

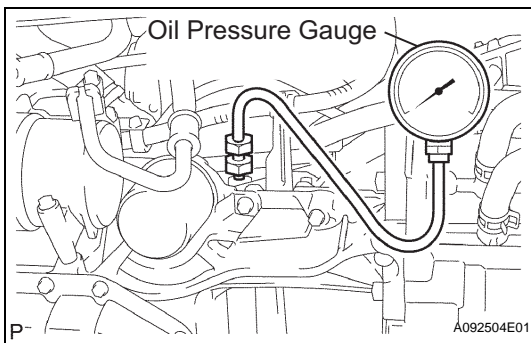
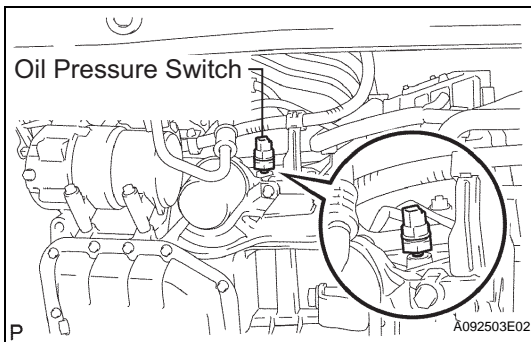
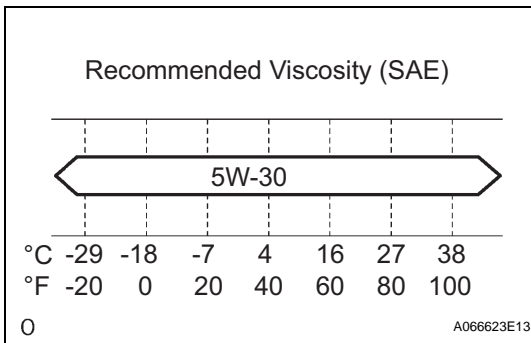

3. CHECK OIL PRESSURE

- (a) Remove the engine oil pressure switch assembly.
- (1) Disconnect the oil pressure switch connector.
 - (2) Using a 24 mm deep socket wrench, remove the oil pressure switch.

- (b) Install an oil pressure gauge.
- (1) Install the adaptor, then install an oil pressure gauge.
- (c) Set the vehicle to inspection mode (see page [IN-34](#)).
- (d) Warm up the engine.
- (e) Inspect the oil pressure.

Standard oil pressure

Condition	Specified Condition
Idle	59 kPa (0.6 kgf/cm ² , 4.2 psi) or more
2,500 rpm	150 to 550 kPa (1.5 to 5.6 kgf/cm ² , 22 to 80 psi)

- (f) Remove the oil pressure gauge.

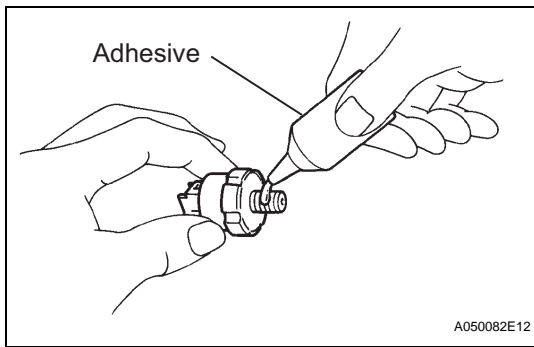

- (g) Install the engine oil pressure switch.
- (1) Apply adhesive to the threads.
Adhesive:
Toyota Genuine Adhesive 1324, Three Bond 1324 or Equivalent
 - (2) Using a 24 mm deep socket wrench, install the oil pressure switch.
Torque: 15 N*m (153 kgf*cm, 11 ft.*lbf)
NOTICE:
Do not start the engine within 1 hour of installation.
 - (3) Connect the oil pressure switch connector.

4. CHECK FOR ENGINE OIL LEAKS

OIL FILTER COMPONENTS

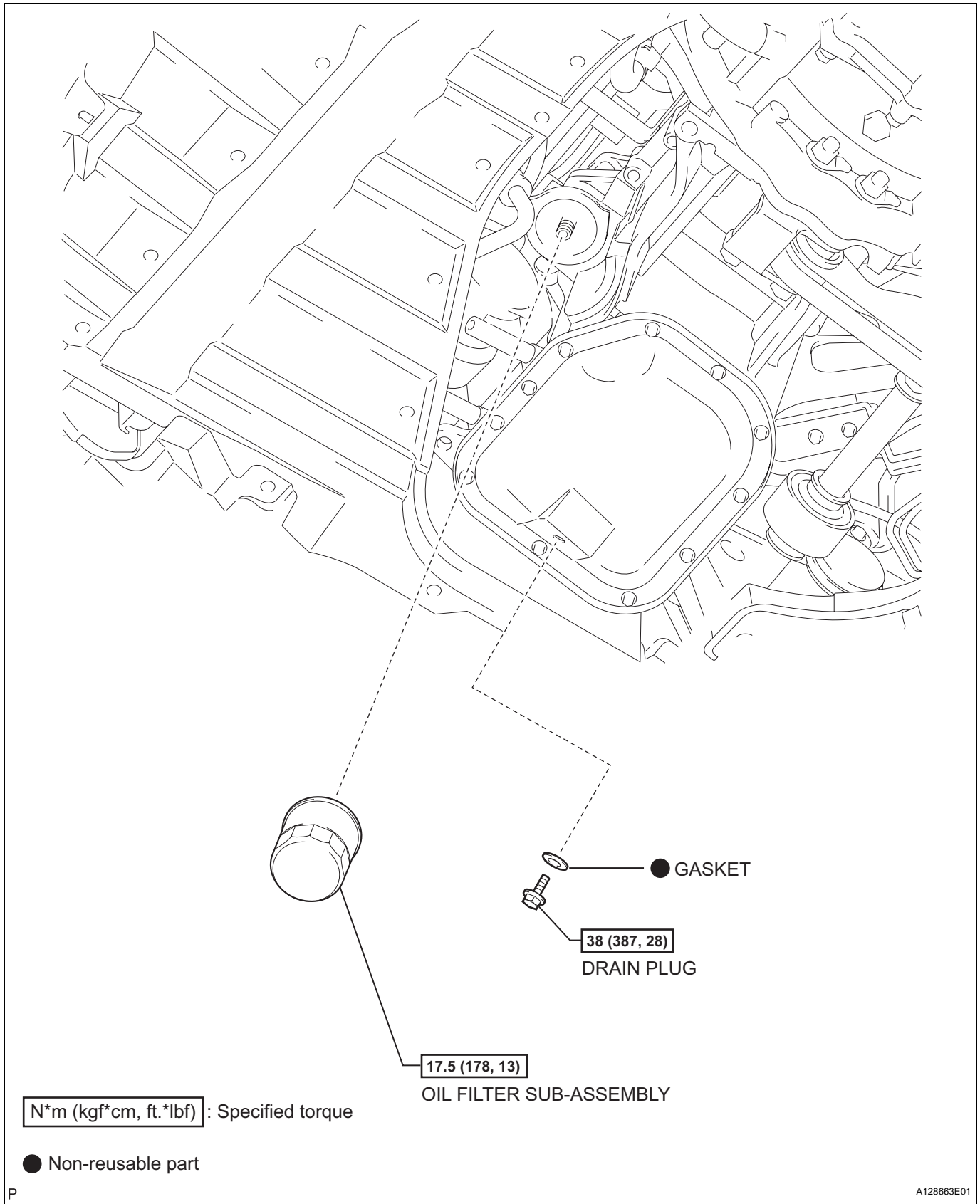

LU

REPLACEMENT

CAUTION:

- Prolonged and repeated contact with engine oil will cause removal of natural oils from the skin, leading to dryness, irritation and dermatitis. In addition, used engine oil contains potentially harmful contaminants which may cause skin cancer.
- Precautions should be taken when replacing engine oil to minimize the risk of your skin making contact with used engine oil. Wear protective clothing and gloves. Wash your skin thoroughly with soap and water, or use a water-less hand cleaner to remove any used engine oil. Do not use gasoline, thinners or solvents.
- For environmental protection, used oil and used oil filter must be disposed of at designated disposal sites.

1. DRAIN ENGINE OIL

- (a) Remove the oil filler cap.
- (b) Remove the oil drain plug, then drain the oil into a container.
- (c) Clean the oil drain plug and install it with a new gasket.

Torque: 38 N*m (387 kgf*cm, 28 ft.*lbf)

2. REMOVE OIL FILTER SUB-ASSEMBLY

- (a) Using SST, remove the oil filter.

SST 09228-06501

3. INSTALL OIL FILTER SUB-ASSEMBLY

- (a) Check and clean the oil filter installation surface.
- (b) Apply clean engine oil to the gasket of a new oil filter.

- (c) Lightly screw the oil filter into place, and tighten it until the gasket contacts the seat.

- (d) Using SST, retighten it by a 3/4 turn.

SST 09228-06501

Torque: 17.5 N*m (178 kgf*cm, 13 ft.*lbf)

4. ADD ENGINE OIL

- (a) Add new oil.

Standard oil capacity

Item	Specified Condition
Drain and refill with oil filter change	3.7 liters (3.9 US qts, 3.3 Imp. qts)
Drain and refill without oil filter change	3.4 liters (3.6 US qts, 3.0 Imp. qts)
Dry fill	4.1 liters (4.3 US qts, 3.6 Imp. qts)

- (b) Install the oil filler cap.

5. CHECK ENGINE OIL LEVEL (See page LU-1)

LU

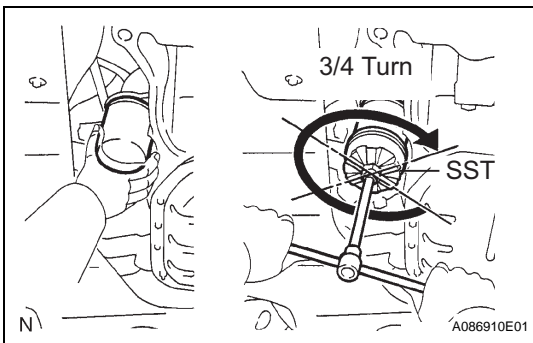
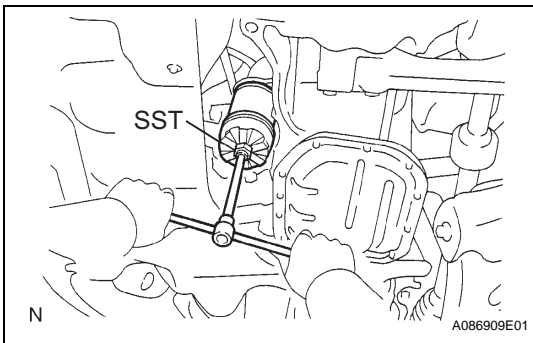

OIL PUMP COMPONENTS

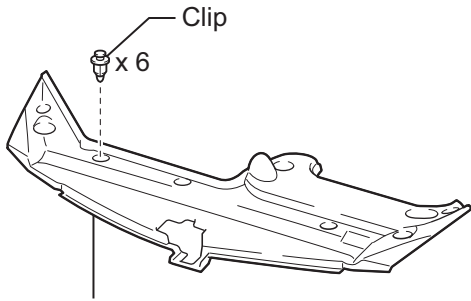

RADIATOR SUPPORT OPENING COVER

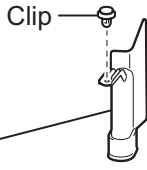

NO. 2 AIR CLEANER INLET

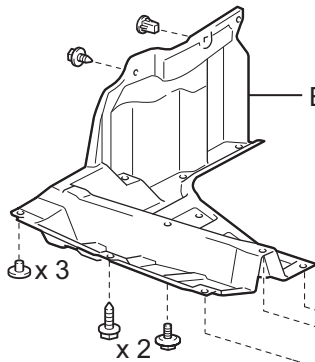
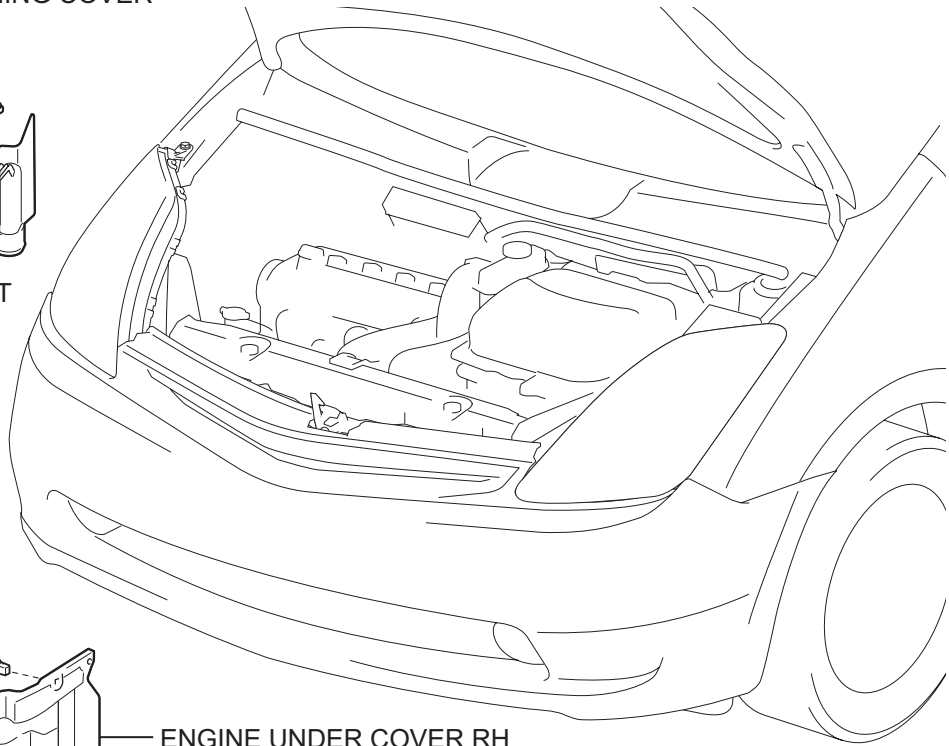

ENGINE UNDER COVER RH

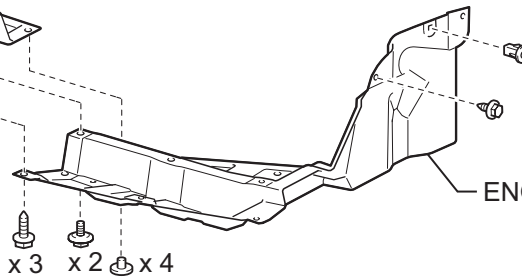

ENGINE UNDER COVER LH

N*m (kgf*cm, ft.*lbf) : Specified torque

LU

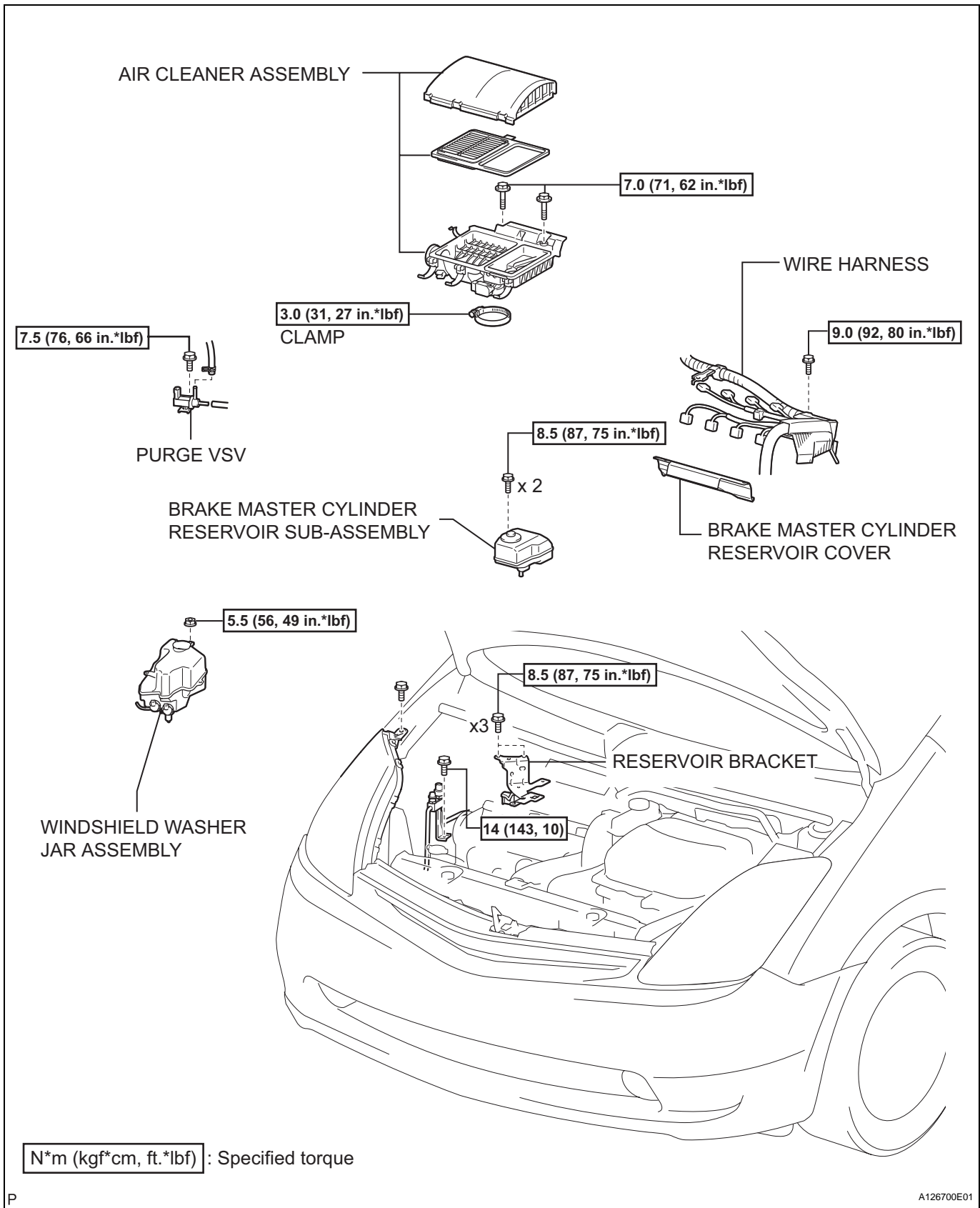

LU

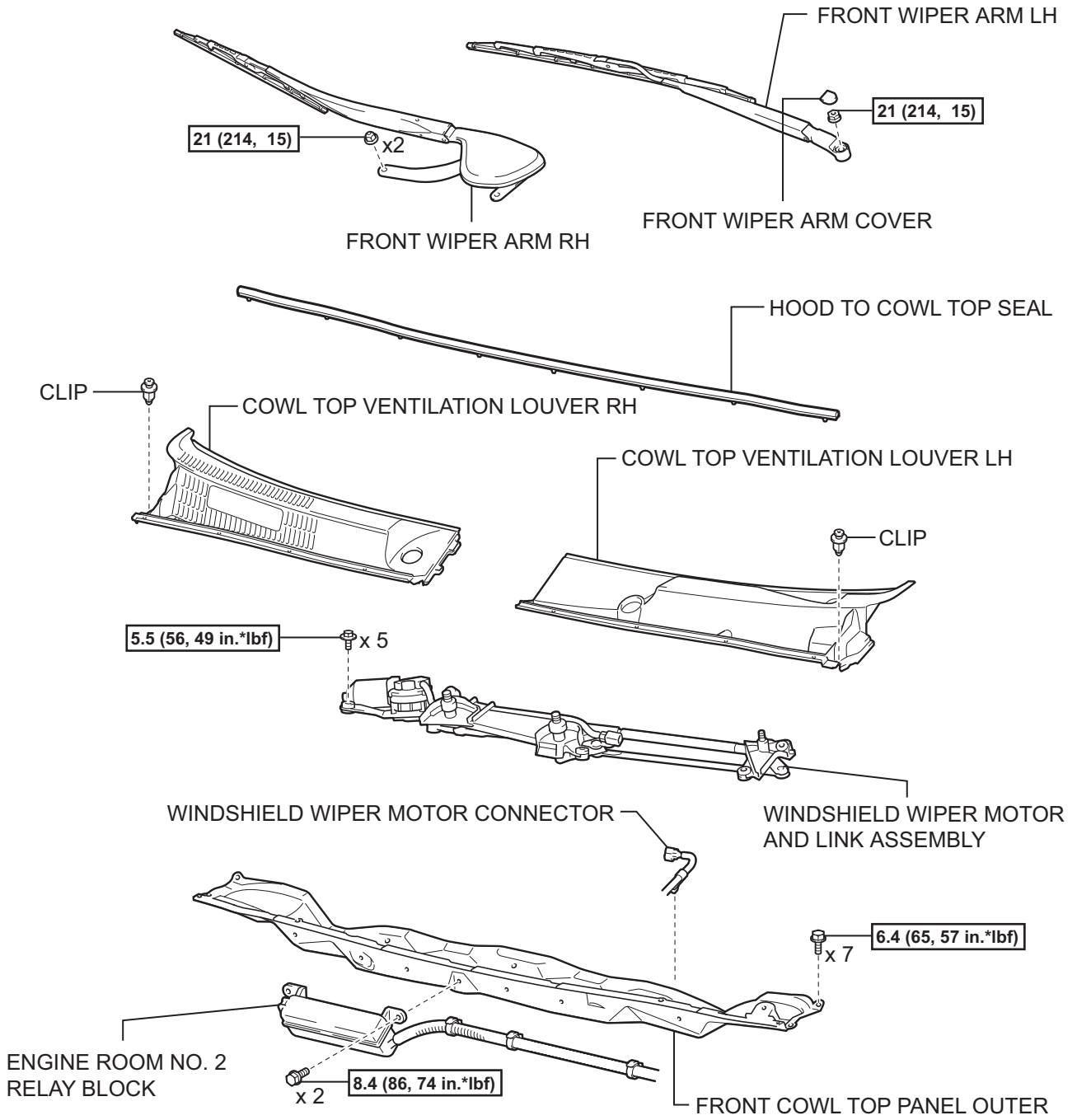

LU

N*m (kgf*cm, ft.*lbf) : Specified torque

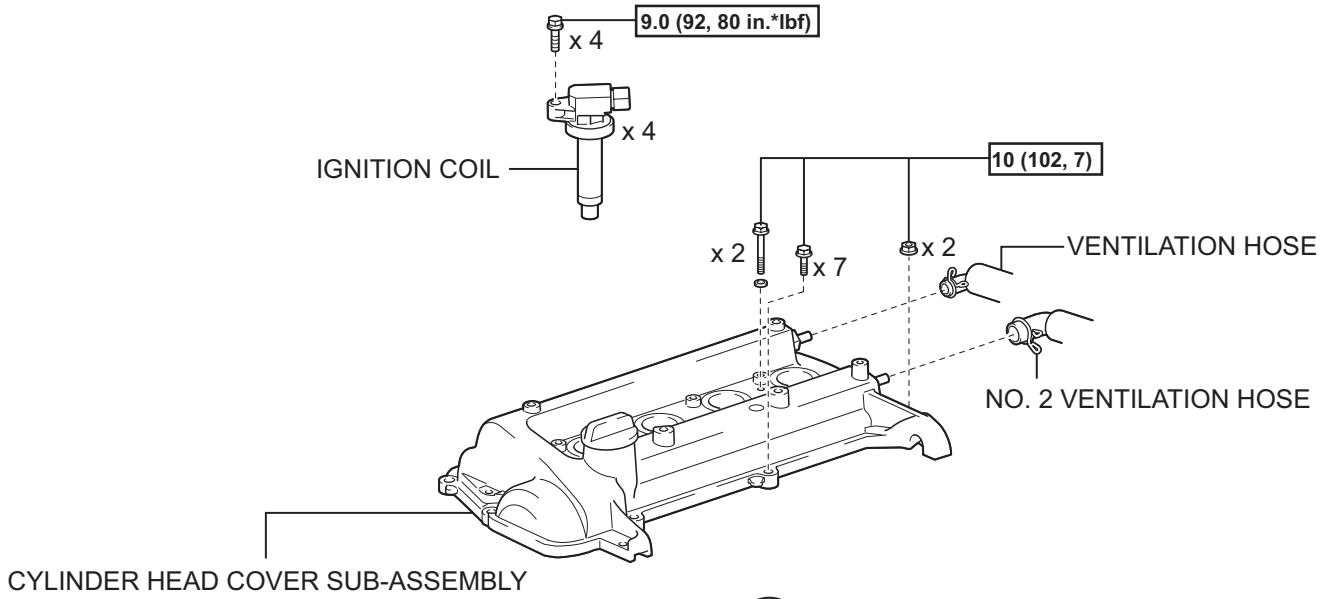

LU

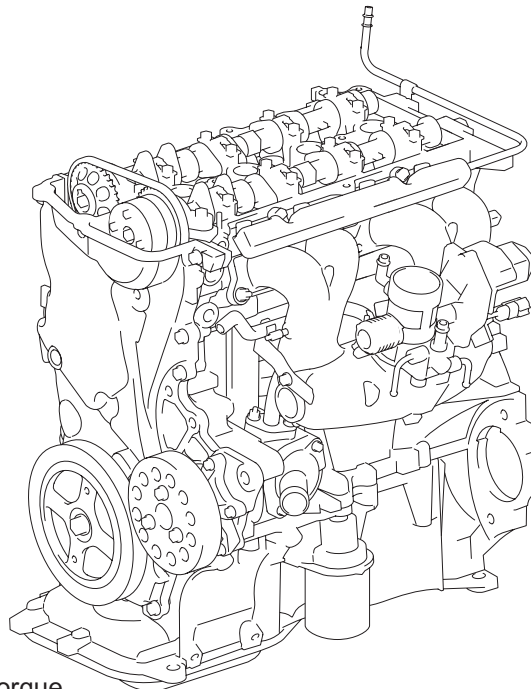
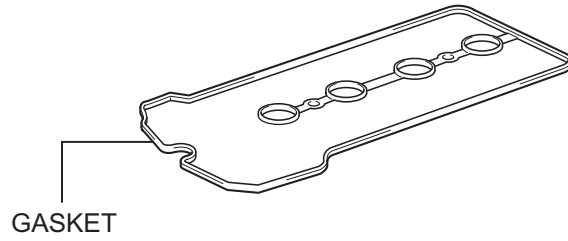

N*m (kgf*cm, ft.*lbf) : Specified torque

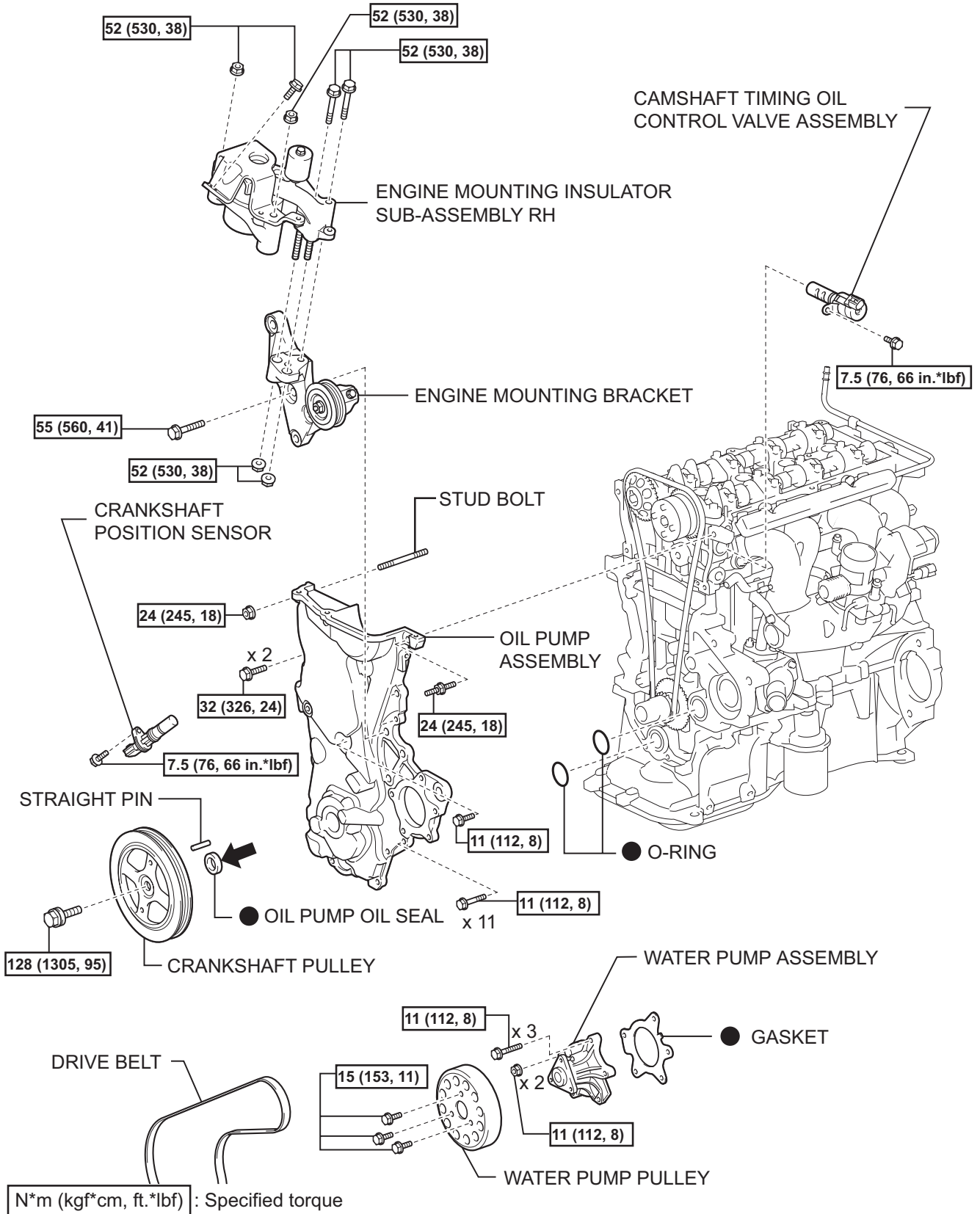

LU

TIMING CHAIN COVER
(OIL PUMP BODY)

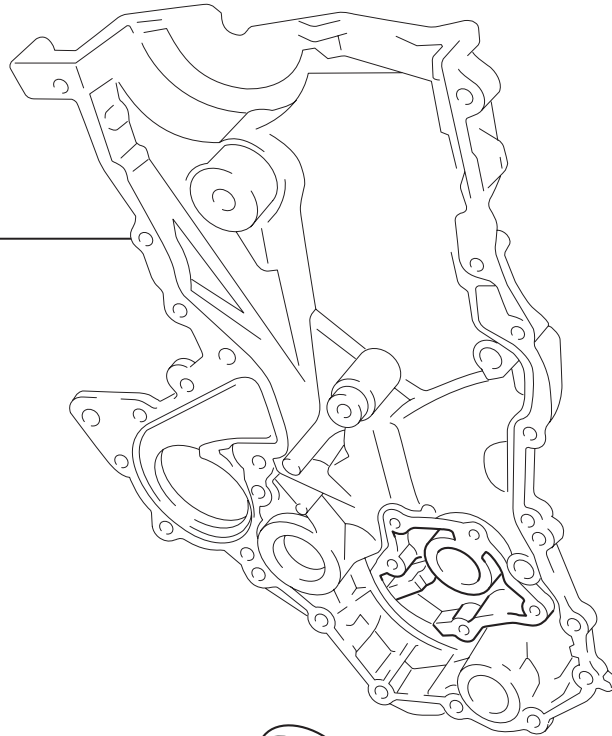

OIL PUMP DRIVEN ROTOR



OIL PUMP DRIVE ROTOR



10 (102, 7.6)



x 3

OIL PUMP COVER

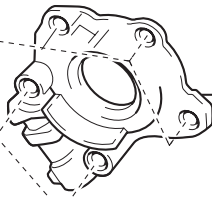

OIL PUMP RELIEF VALVE

8.8. (90, 78 in.*lbf)



x 2

OIL PUMP RELIEF VALVE SPRING



25 (255, 18)

N*m (kgf*cm, ft.*lbf) : Specified torque

LU

REMOVAL

1. REMOVE REAR NO. 2 FLOOR BOARD (See page [HB-153](#))
2. REMOVE REAR DECK FLOOR BOX (See page [HB-153](#))
3. REMOVE REAR NO. 3 FLOOR BOARD (See page [HB-153](#))
4. DISCONNECT CABLE FROM NEGATIVE BATTERY TERMINAL
CAUTION:
 Wait at least 90 seconds after disconnecting the cable from the negative (-) battery terminal to prevent airbag and seat belt pretensioner activation.
5. REMOVE SERVICE PLUG GRIP (See page [HB-154](#))
6. REMOVE RADIATOR SUPPORT OPENING COVER (See page [CO-6](#))
7. REMOVE FRONT WHEEL RH
8. REMOVE ENGINE UNDER COVER LH
9. REMOVE ENGINE UNDER COVER RH
10. DRAIN ENGINE COOLANT (See page [CO-6](#))
11. DRAIN ENGINE OIL (See page [LU-4](#))
12. REMOVE WINDSHIELD WIPER MOTOR AND LINK ASSEMBLY
 - (a) Remove the windshield wiper motor and link assembly (see page [WW-13](#)).
13. REMOVE FRONT COWL TOP PANEL OUTER (See page [FU-12](#))
14. REMOVE AIR CLEANER ASSEMBLY
 - (a) Loosen the clamp, then disconnect the No. 1 air cleaner inlet from the air cleaner case.

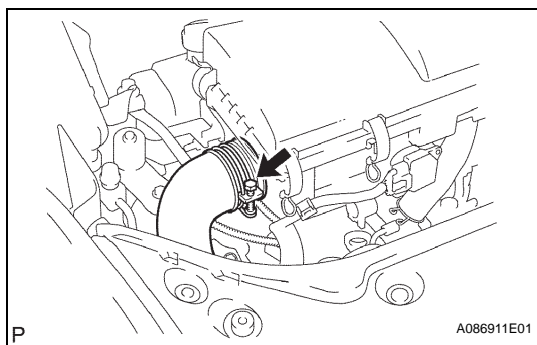

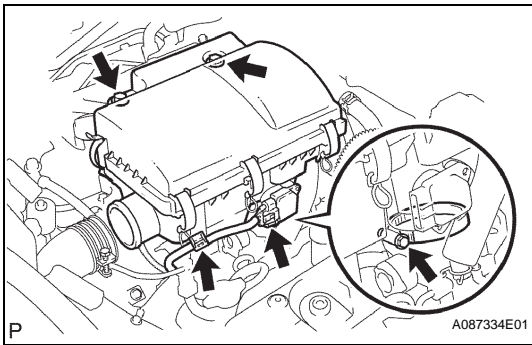

- (b) Disconnect the mass air flow meter connector, then remove the wire harness clamp.
- (c) Loosen the clamp, then remove the 2 bolts and air cleaner assembly.

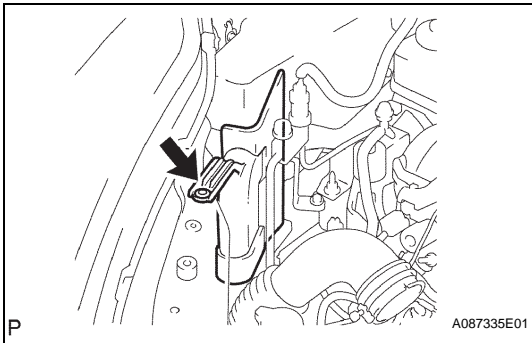

15. REMOVE NO. 2 AIR CLEANER INLET

- (a) Remove the clip and air cleaner inlet.

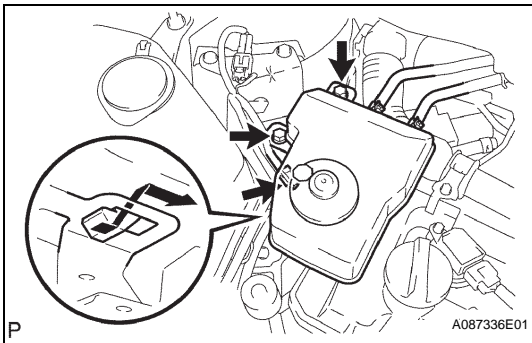

16. SUSPEND BRAKE MASTER CYLINDER RESERVOIR SUB-ASSEMBLY

- (a) Disconnect the connector.
- (b) Remove the 2 bolts.
- (c) Separate the claw fitting, then suspend the brake master cylinder reservoir with a rope.

NOTICE:

Be careful of the angle of the brake master cylinder reservoir when suspending to prevent air from coming into the hose.

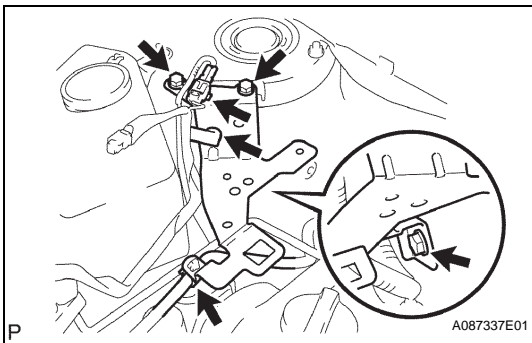

17. REMOVE RESERVOIR BRACKET

- (a) Disconnect the hose from the brake master cylinder reservoir bracket.
- (b) Remove the 3 bolts and wire harness clamp, then remove the brake master cylinder reservoir bracket.

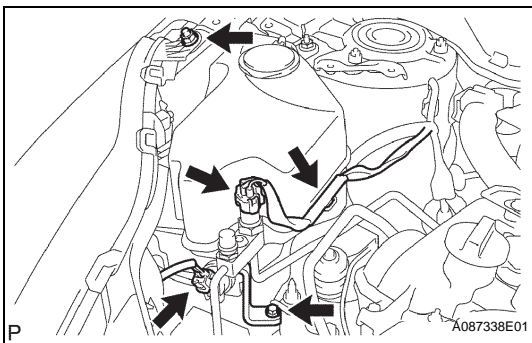

18. REMOVE WINDSHIELD WASHER JAR ASSEMBLY

- (a) Loosen the bolt which holds the headlight RH.
- (b) Disconnect the connector and remove the wire harness clamp.
- (c) Remove the bolt and bracket.

LU

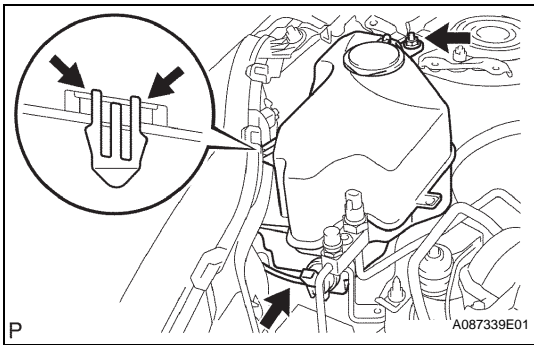

- (d) Remove the nut.
- (e) Slightly lift the headlight RH and separate the claw fitting, then remove the washer jar.
- (f) Disconnect the hose from the washer jar.

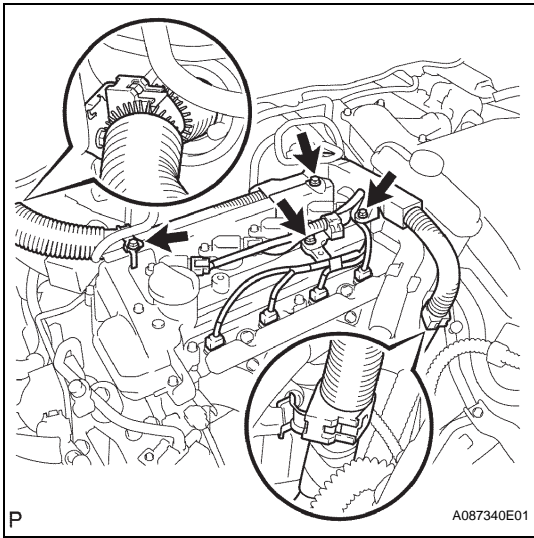

19. REMOVE CYLINDER HEAD COVER SUB-ASSEMBLY

- (a) Disconnect the fuel injector connector and ignition coil connector.
- (b) Remove the 3 bolts and wire harness clamp, then disconnect the wire harness.

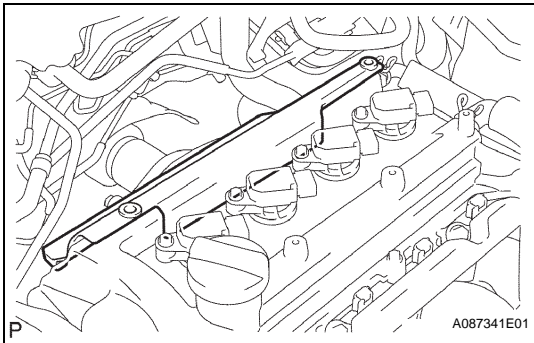

- (c) Remove the brake master cylinder reservoir cover.

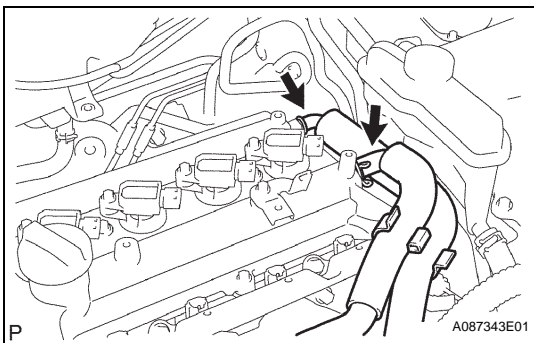

- (d) Disconnect the ventilation hose and No. 2 ventilation hose.

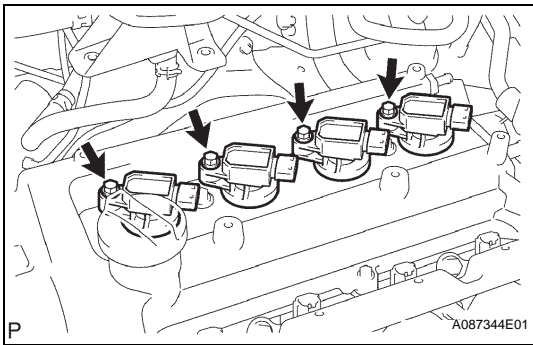

(e) Remove the 4 bolts and 4 ignition coils.

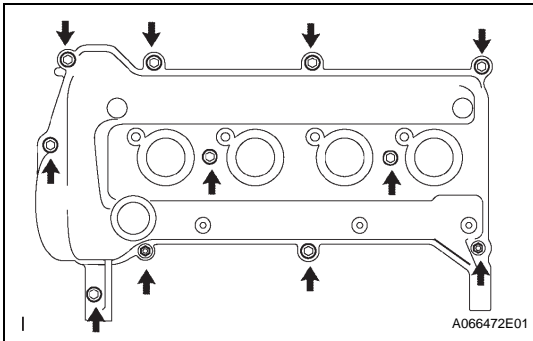

(f) Remove the 9 bolts and 2 nuts, then remove the cylinder head cover.

20. REMOVE PURGE VSV (See page EC-23)

21. REMOVE DRIVE BELT (See page EM-6)

22. REMOVE WATER PUMP PULLEY (See page CO-11)

23. REMOVE WATER PUMP ASSEMBLY (See page CO-11)

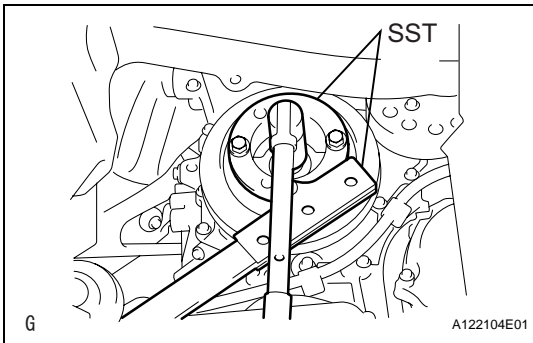

24. REMOVE CRANKSHAFT PULLEY

(a) Using SST, hold the crankshaft pulley and loosen the crankshaft bolt.

SST 09213-58013 (91111-50845), 09330-00021

NOTICE:

When installing SST, be careful that the bolt which holds SST does not interfere with the chain cover.

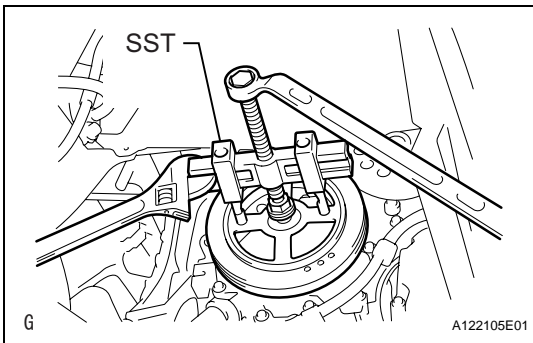

(b) Loosen the crankshaft bolt until the 2 to 3 threads of the bolt is tightened to the crankshaft.

(c) Using SST, remove the crankshaft pulley.

SST 09950-50013 (09951-05010, 09952-05010, 09953-05020, 09954-05021)

(d) Remove the crankshaft bolt.

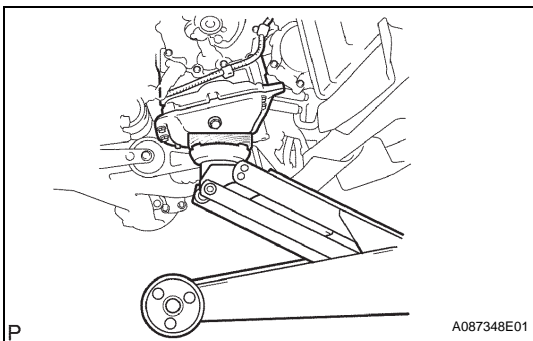

25. REMOVE ENGINE MOUNTING INSULATOR SUB-ASSEMBLY RH

(a) Place a transmission jack underneath the engine, then put a wooden block on the jack.

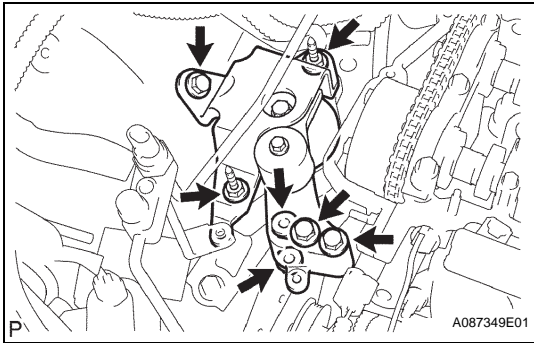

- (b) Remove the 3 bolts and 4 nuts, then remove the engine mounting insulator RH.

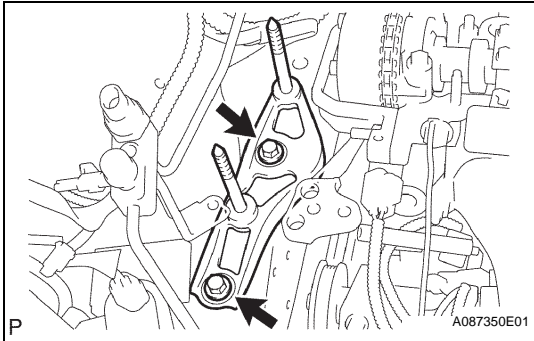

26. REMOVE ENGINE MOUNTING SPACER

- (a) Remove the 2 bolts and engine mounting spacer.

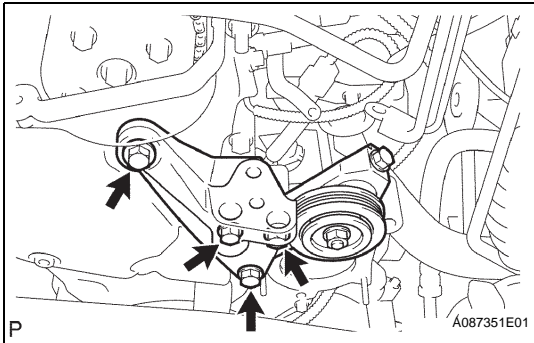

27. REMOVE ENGINE MOUNTING BRACKET

- (a) Remove the 4 bolts and engine mounting bracket.

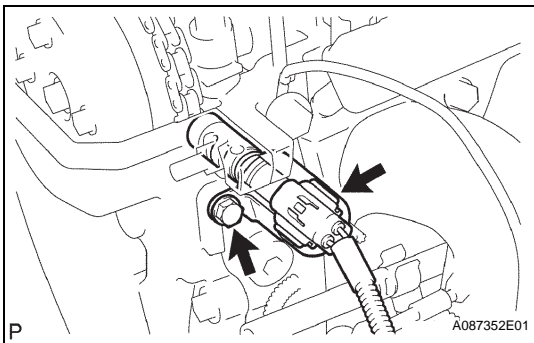

28. REMOVE CAMSHAFT TIMING OIL CONTROL VALVE ASSEMBLY

- (a) Disconnect the connector.
 (b) Remove the bolt and camshaft timing oil control valve.

29. REMOVE CRANKSHAFT POSITION SENSOR (See page [ES-443](#))

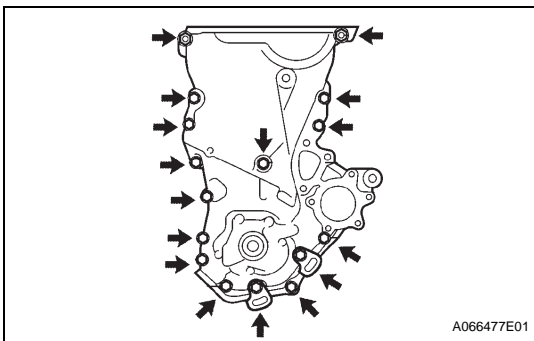

30. REMOVE OIL PUMP ASSEMBLY

- (a) Remove the 15 bolts and nut.

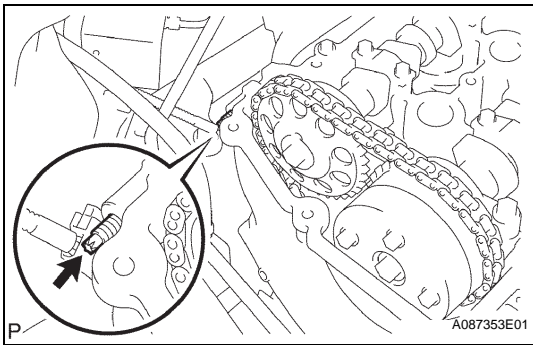

- (b) Using an E8 "torx" socket wrench, remove the stud bolt.

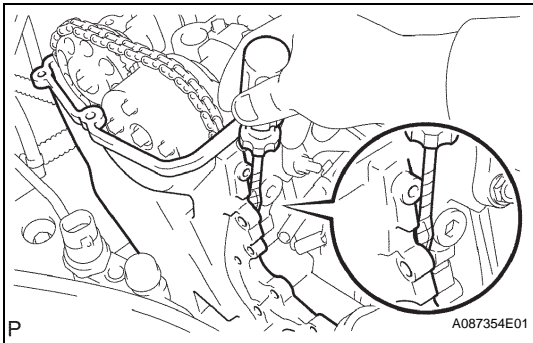

- (c) Using a screwdriver with its tip wrapped in tape, remove the oil pump by prying out between the cylinder head and cylinder block.

NOTICE:

Be careful not to damage the contact surfaces of the oil pump assembly, cylinder head and cylinder block.

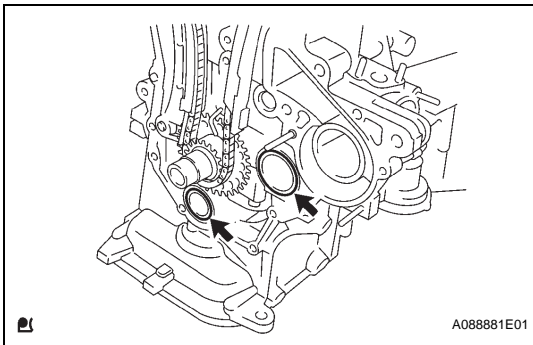

- (d) Remove the 2 O-rings.

LU

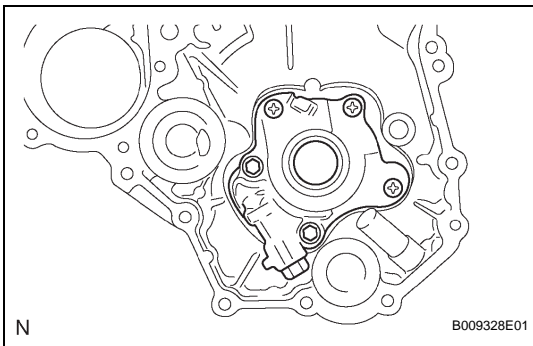

DISASSEMBLY

1. REMOVE OIL PUMP ROTOR SET

- (a) Remove the 2 bolts and 3 screws, then remove the oil pump cover.

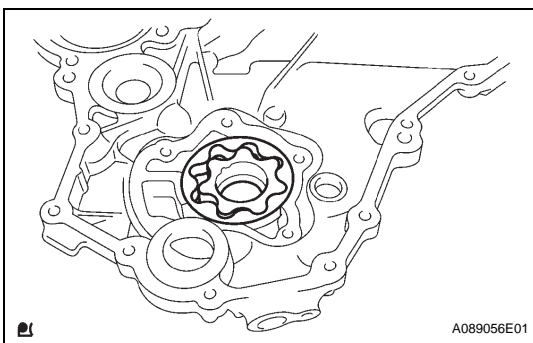

- (b) Remove the oil pump rotor set from the oil pump body.

NOTICE:

Keep the 2 removed rotors without changing the arrangement or turning them over.

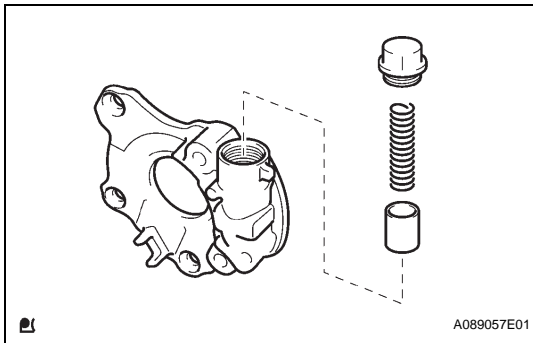

2. REMOVE OIL PUMP RELIEF VALVE

- (a) Remove the oil pump relief valve plug, then remove the oil pump relief valve spring and oil pump relief valve.

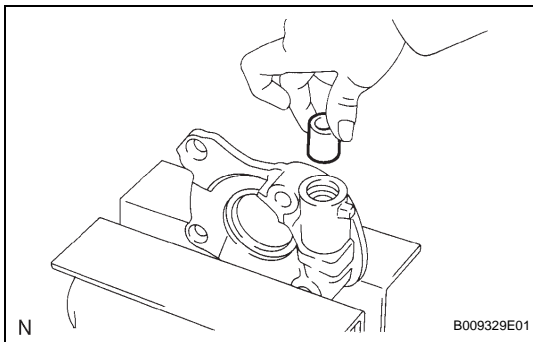

INSPECTION

1. INSPECT OIL PUMP RELIEF VALVE

- (a) Apply engine oil to the oil pump relief valve. Check that the valve falls smoothly into the valve hole of the oil pump body by its own weight.

2. INSTALL OIL PUMP ASSEMBLY

- (a) Check the operation.
 - (1) Apply engine oil to the drive and driven rotors. Install the rotors to the oil pump body, then check that the rotors revolve smoothly.

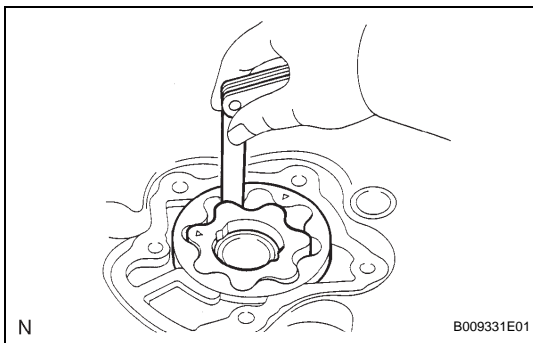

- (b) Inspect the tip clearance.

- (1) Using a feeler gauge, measure the clearance between the drive and driven rotor tips.

Standard tip clearance:

0.060 to 0.180 mm (0.0024 to 0.0071 in.)

Maximum tip clearance:

0.28 mm (0.0110 in.)

If the tip clearance is greater than the maximum, replace the oil pump assembly.

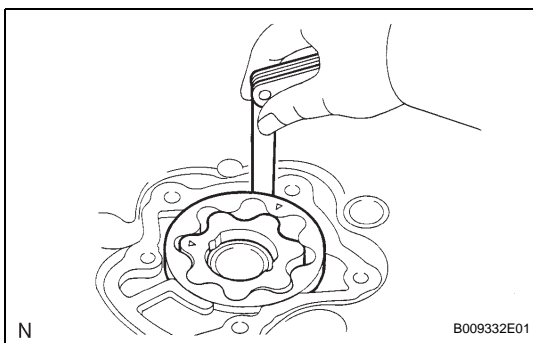

- (c) Inspect the body clearance.

- (1) Using a feeler gauge, measure the clearance between the driven rotor and oil pump body.

Standard body clearance:

0.250 to 0.325 mm (0.0098 to 0.0128 in.)

Maximum body clearance:

0.425 mm (0.0167 in.)

If the body clearance is greater than the maximum, replace the oil pump assembly.

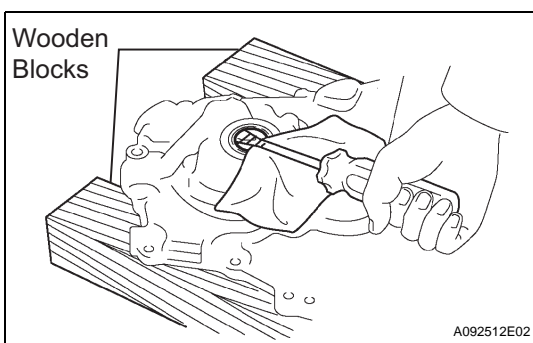

REPLACEMENT

1. REPLACE OIL PUMP OIL SEAL

- (a) Using a screwdriver with its tip wrapped in tape, remove the oil seal.

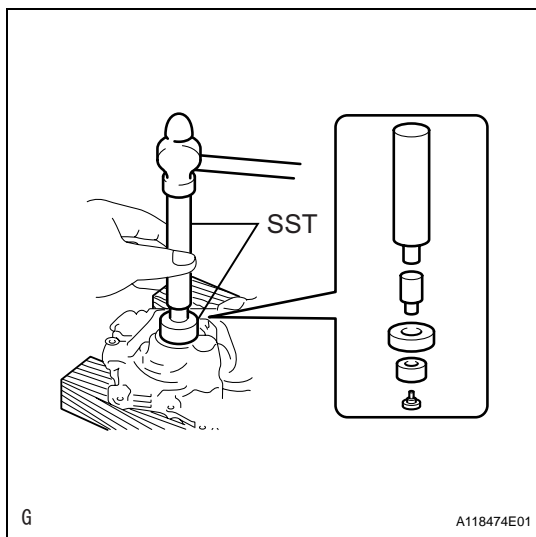

- (b) Using SST, uniformly tap in a new oil seal until its surface is flush with the oil pump edge.
SST 09950-60010 (09951-00250, 09951-00380, 09952-06010), 09950-70010 (09951-07100)

NOTICE:

Be careful not to tap the oil seal at an angle.

- (c) Apply a light coat of No. 2 multipurpose grease to the lip of the oil seal.

NOTICE:

Keep the lip free of foreign objects.

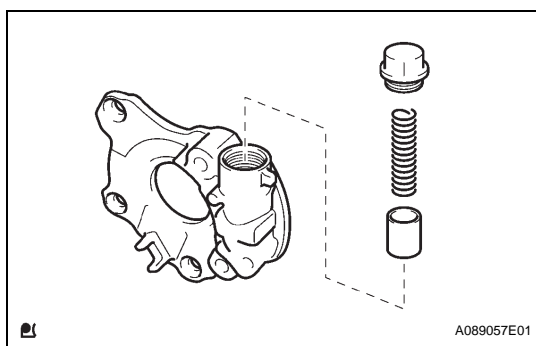
**REASSEMBLY****1. INSTALL OIL PUMP RELIEF VALVE**

- (a) Apply engine oil to the oil pump relief valve.
 (b) Install the oil pump relief valve and oil pump relief valve spring to the oil pump cover.
 (c) Install the oil pump relief valve plug.

Torque: 25 N*m (255 kgf*cm, 18 ft.*lbf)

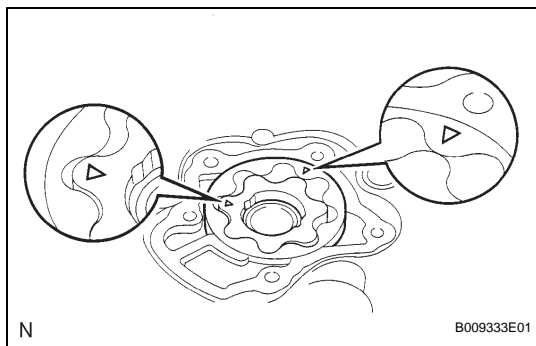
**2. INSTALL OIL PUMP ROTOR SET**

- (a) Apply engine oil to the drive and driven rotors.
 (b) Install the rotors to the oil pump body with the marks facing upward.

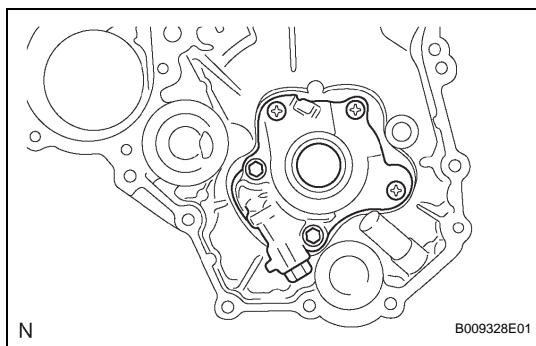

- (c) Install the oil pump cover with the 2 bolts and 3 screws.

**Torque: 8.8 N*m (90 kgf*cm, 78 in.*lbf) for bolt
 10 N*m (102 kgf*cm, 7 ft.*lbf) for screw**

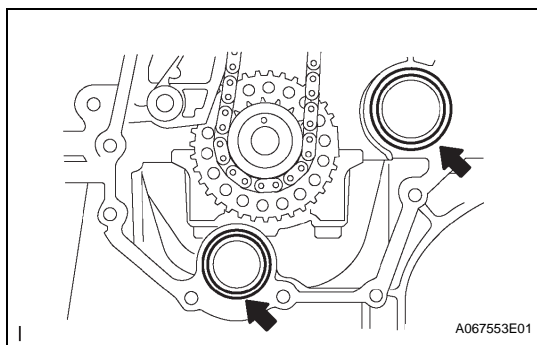

INSTALLATION

1. INSTALL OIL PUMP ASSEMBLY

- (a) Install 2 new O-rings to the 2 locations as shown in the illustration.
- (b) Apply seal packing to the engine body and oil pump as shown in the illustration below.

Seal packing:

Water pump part: Toyota Genuine Seal Packing 1282B, Three Bond 1282B or Equivalent

Other part: Toyota Genuine Seal Packing Black, Three Bond 1207B or Equivalent

NOTICE:

- Remove pump any oil from the contact surface.
- Install the oil pump within 3 minutes, and tighten the bolts within 15 minutes after applying seal packing.
- Do not expose the seal packing to engine oil within 2 hours of installation.

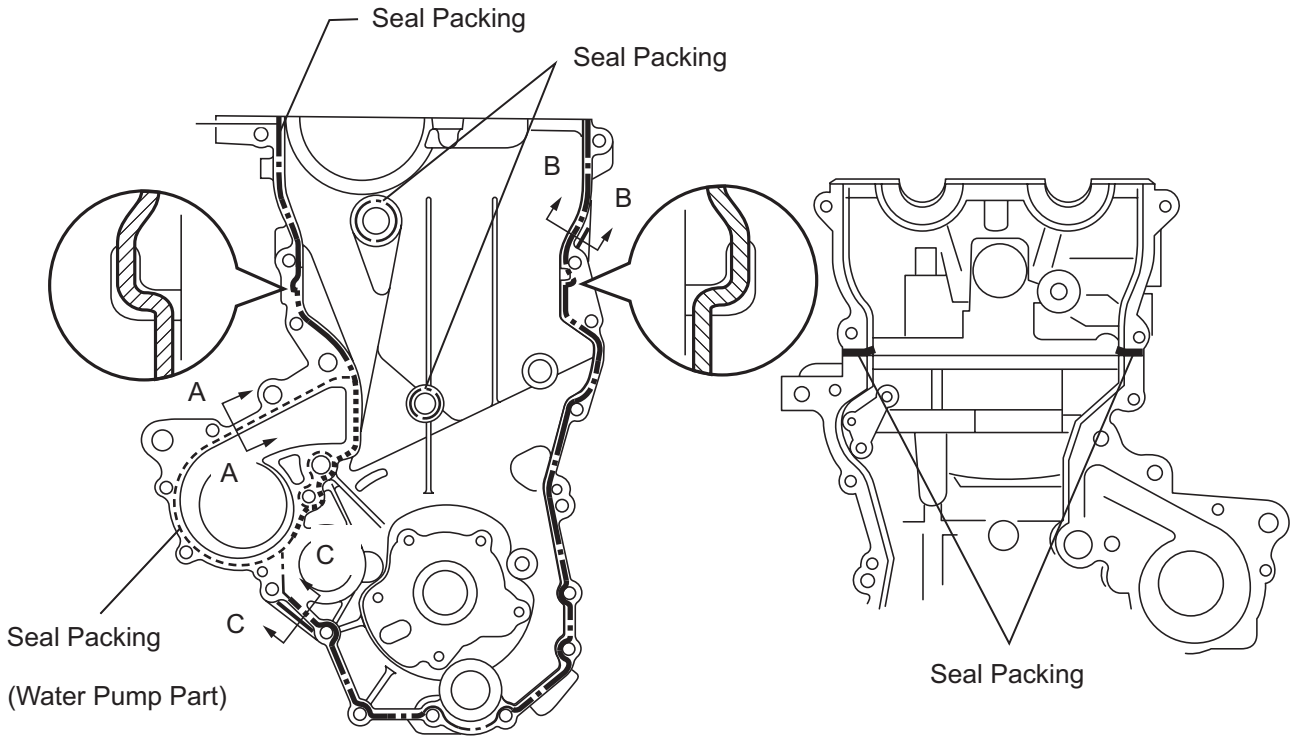

A - A

Diameter:
1.5 to 2.0 mm
(0.059 to 0.078 in.)

B - B, C - C
(After Assembling)

2.5 mm
(0.098 in.)

5.0 mm
(0.197 in.)

1.5 mm
(0.059 in.)



2.5 mm (0.098 in.) or more

B - B, C - C

2.5 mm
(0.098 in.)

Diameter:

1.0 mm
(0.039 in.)

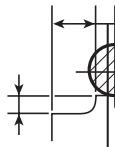

3.5 to 4.5 mm
(0.138 to 0.177 in.)

1.0 mm
(0.039 in.)

Other Part

Seal Diameter:

— · — · — · — 3.5 to 4.5 mm (0.138 to 0.177 in.)

— · — · — · — 1.5 to 2.0 mm (0.059 to 0.078 in.)

Water Pump Part

Seal Diameter:

······ 3.5 to 4.5 mm (0.138 to 0.177 in.)

----- 1.5 to 2.0 mm (0.059 to 0.078 in.)

A117400E03

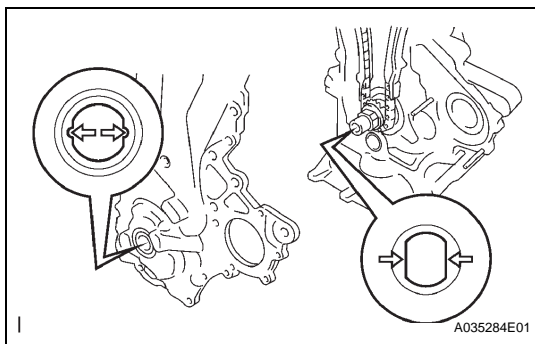

(c) Align the drive rotor spline of the oil pump with the rectangular portion of the crankshaft, then slide the oil pump into place.

A035284E01

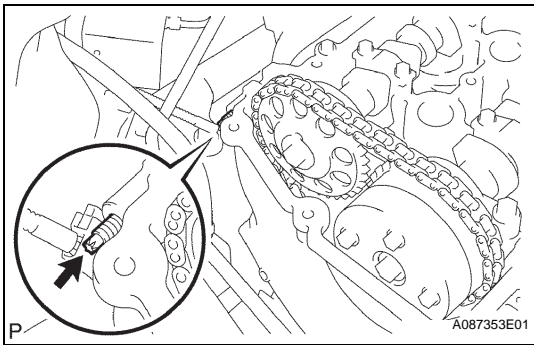

- (d) Using an E8 "torx" socket wrench, install the stud bolt.

Torque: 10 N*m (102 kgf*cm, 7.4 ft.*lbf)

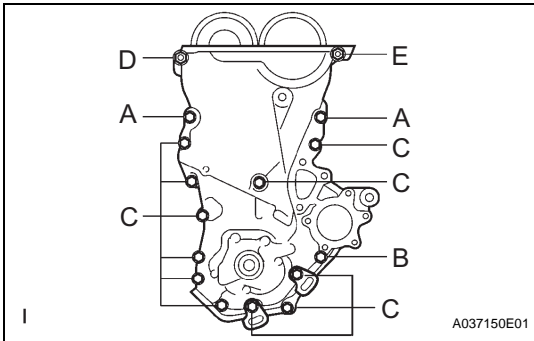

- (e) Install the oil pump with the 15 bolts and nut as illustrated.

Torque: 32 N*m (326 kgf*cm, 24 ft.*lbf) for bolt A

11 N*m (112 kgf*cm, 8 ft.*lbf) for bolt B

11 N*m (112 kgf*cm, 8 ft.*lbf) for bolt C

24 N*m (245 kgf*cm, 18 ft.*lbf) for bolt D

24 N*m (245 kgf*cm, 18 ft.*lbf) for bolt E

NOTICE:

- Be careful that the chain does not contact the seal packing when installing the oil pump.
- Install the engine mounting bracket RH and water pump within 15 minutes after installing the oil pump.

2. **INSTALL CRANKSHAFT POSITION SENSOR** (See page [ES-443](#))

3. **INSTALL CAMSHAFT TIMING OIL CONTROL VALVE ASSEMBLY**

- (a) Apply a light coat of engine oil to the O-ring.

- (b) Install the camshaft timing oil control valve with the bolt.

Torque: 7.5 N*m (76 kgf*cm, 66 in.*lbf)

4. **INSTALL ENGINE MOUNTING BRACKET**

Torque: 55 N*m (561 kgf*cm, 41 ft.*lbf)

5. **INSTALL ENGINE MOUNTING SPACER**

Torque: 52 N*m (530 kgf*cm, 38 ft.*lbf)

6. **INSTALL ENGINE MOUNTING INSULATOR SUB-ASSEMBLY RH**

- (a) Install the engine mounting insulator with the 3 bolts and 4 nuts.

Torque: 52 N*m (530 kgf*cm, 38 ft.*lbf)

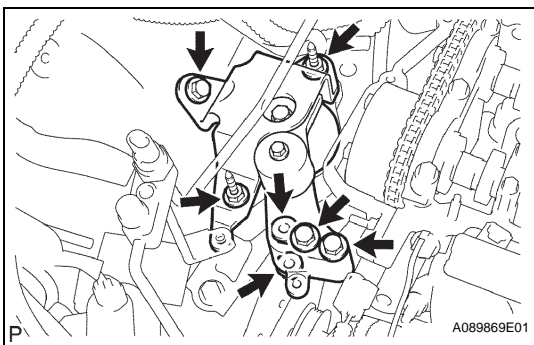

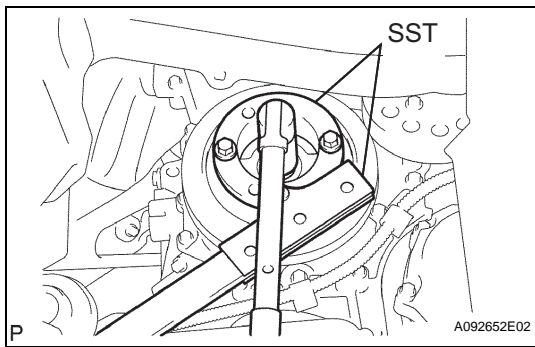

7. INSTALL CRANKSHAFT PULLEY

- (a) Align the hole of the crankshaft pulley with the straight pin, then install the crankshaft pulley.
- (b) Using SST, hold the crankshaft pulley and tighten the crankshaft bolt.

SST 09213-58013 (91111-50845), 09330-00021
Torque: 128 N*m (1305 kgf*cm, 95 ft.*lbf)

NOTICE:

When installing SST, be careful that the bolt which holds SST does not interfere with the chain cover.

8. INSTALL WATER PUMP ASSEMBLY (See page CO-11)

9. INSTALL WATER PUMP PULLEY (See page CO-11)

10. INSTALL DRIVE BELT (See page EM-6)

11. INSTALL PURGE VSV (See page EC-24)

12. INSTALL CYLINDER HEAD COVER SUB-ASSEMBLY

- (a) Apply seal packing to the 2 locations shown in the illustration, then install the cylinder head cover.

Seal packing:

Toyota Genuine Seal Packing Black, Three Bond 1207B or Equivalent

NOTICE:

- Remove any oil from the contact surface.
- Install the cylinder head cover within 3 minutes after applying seal packing.
- Do not start the engine within 2 hours of installing.

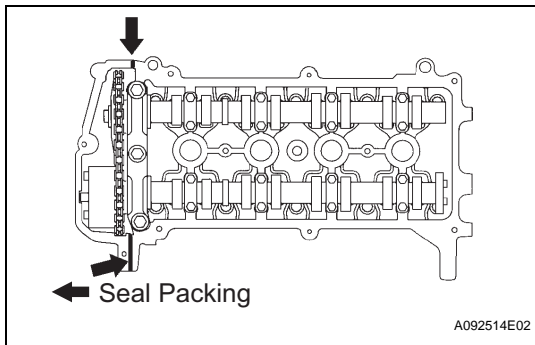

- (b) Install the cylinder head cover with the 9 bolts and 2 nuts.

- (c) Using several steps, tighten the bolts and nuts with the specified torque in the sequence shown in the illustration.

Torque: 10 N*m (102 kgf*cm, 7 ft.*lbf)

- (d) Install the ignition coil with the bolt.

Torque: 9.0 N*m (92 kgf*cm, 80 in.*lbf)

- (e) Install the brake master cylinder reservoir cover to the cylinder head cover.

- (f) Install the wire harness and brake master cylinder reservoir cover with the 3 bolts.

Torque: 9.0 N*m (92 kgf*cm, 80 in.*lbf)

- (g) Connect the fuel injector connector and ignition coil connector.

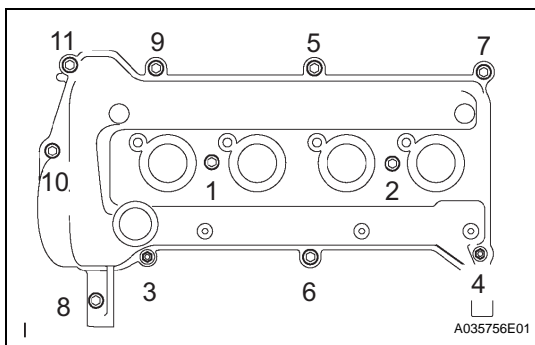

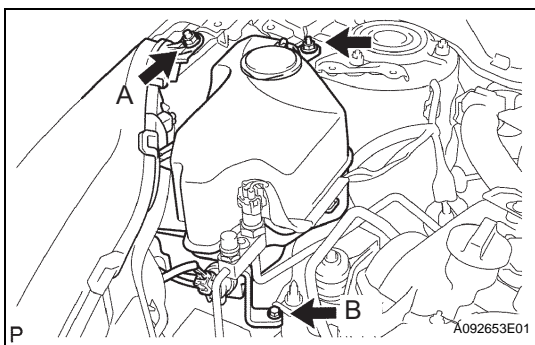

13. **INSTALL WINDSHIELD WASHER JAR ASSEMBLY**
Torque: 4.9 N*m (50 kgf*cm, 43 in.*lbf) for bolt A
14 N*m (143 kgf*cm, 10 ft.*lbf) for bolt B
5.5 N*m (56 kgf*cm, 49 in.*lbf) for nut
14. **INSTALL RESERVOIR BRACKET**
Torque: 8.5 N*m (87 kgf*cm, 75 in.*lbf)
15. **INSTALL BRAKE MASTER CYLINDER RESERVOIR SUB-ASSEMBLY**
Torque: 8.5 N*m (87 kgf*cm, 75 in.*lbf)
16. **INSTALL NO. 2 AIR CLEANER INLET**
17. **INSTALL AIR CLEANER ASSEMBLY** (See page [EC-29](#))
18. **INSTALL FRONT COWL TOP PANEL OUTER** (See page [FU-19](#))
19. **INSTALL WINDSHIELD WIPER MOTOR AND LINK ASSEMBLY**
(a) Install the windshield wiper motor and wiper link assembly (see page [WW-15](#)).
20. **ADD ENGINE OIL** (See page [LU-4](#))
21. **INSTALL SERVICE PLUG GRIP** (See page [HB-154](#))
22. **CONNECT CABLE TO NEGATIVE BATTERY TERMINAL** (See page [CH-7](#))
23. **INSTALL REAR NO. 3 FLOOR BOARD** (See page [CH-8](#))
24. **INSTALL REAR DECK FLOOR BOX** (See page [CH-8](#))
25. **INSTALL REAR NO. 2 FLOOR BOARD** (See page [CH-8](#))
26. **ADD ENGINE COOLANT** (See page [CO-7](#))
27. **CHECK FOR ENGINE COOLANT LEAKS** (See page [CO-9](#))
28. **CHECK FOR ENGINE OIL LEAKS**
29. **INSTALL RADIATOR SUPPORT OPENING COVER**
30. **INSTALL ENGINE UNDER COVER RH**
31. **INSTALL ENGINE UNDER COVER LH**
32. **INSTALL FRONT WHEEL RH**
Torque: 103 N*m (1050 kgf*cm, 76 ft.*lbf)
33. **PERFORM INITIALIZATION**
(a) Perform initialization (see page [IN-32](#)).
NOTICE:
Certain systems need to be initialized after disconnecting and reconnecting the cable from the negative (-) battery terminal.