

SEAT BELT WARNING SYSTEM

PARTS LOCATION

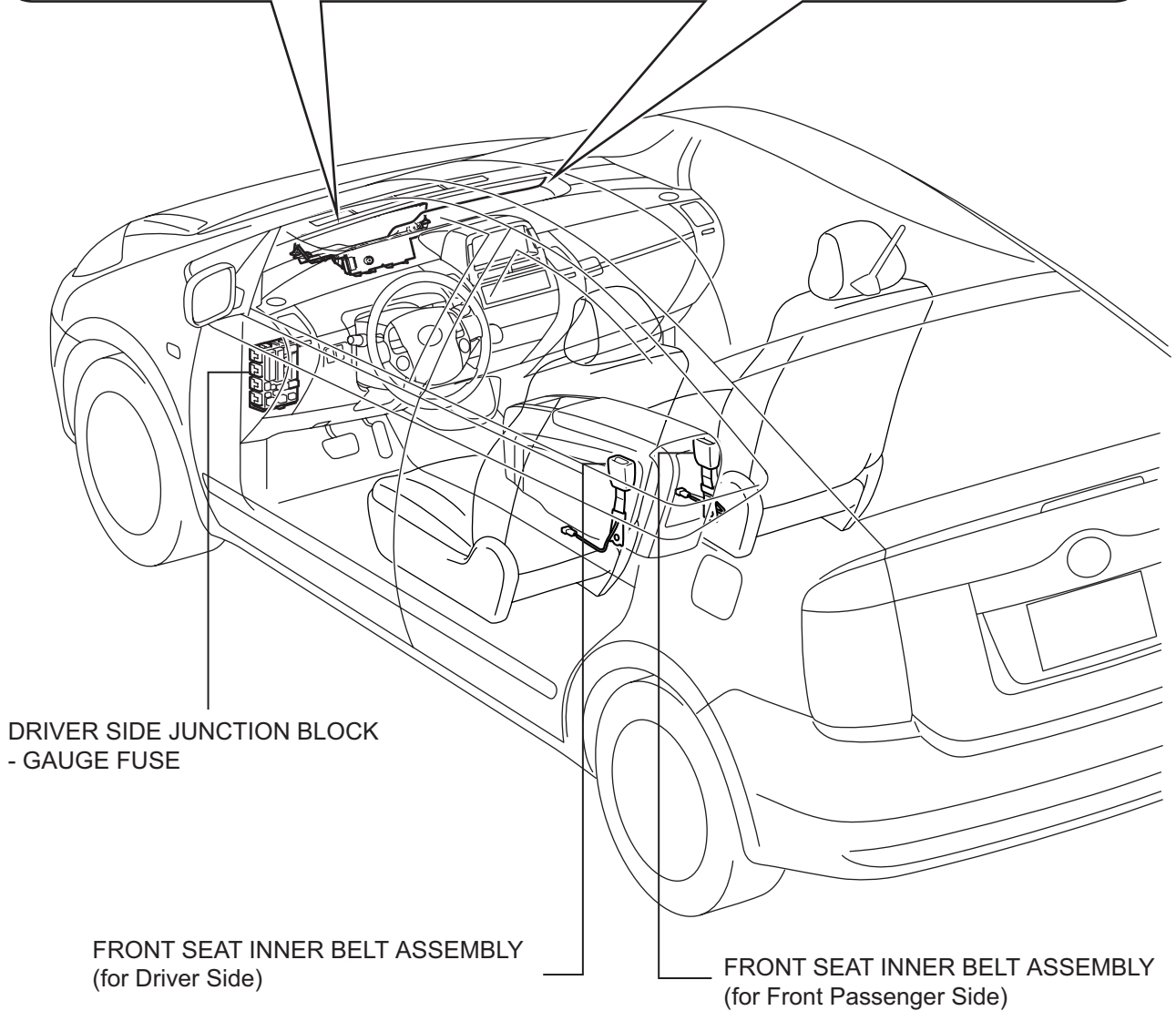
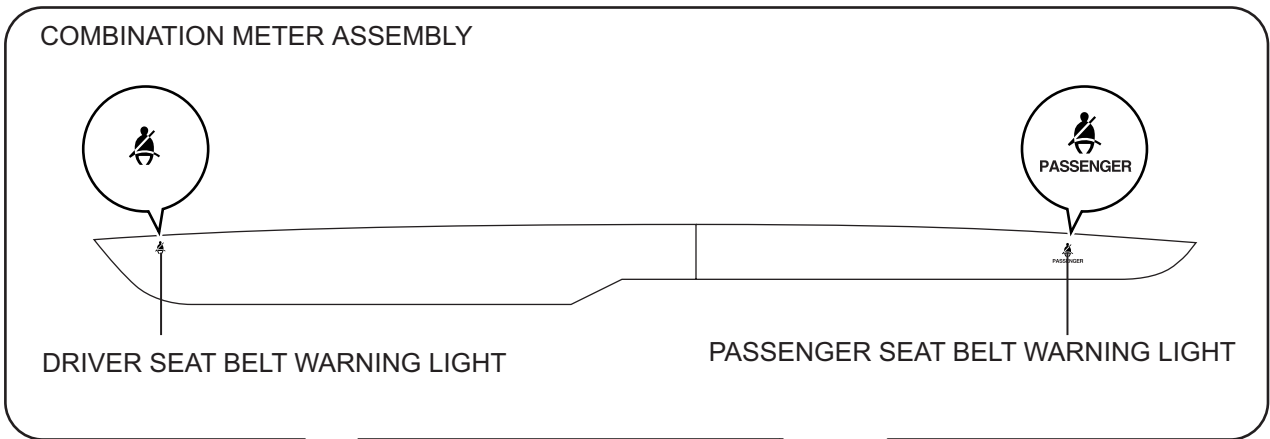

SB

SB

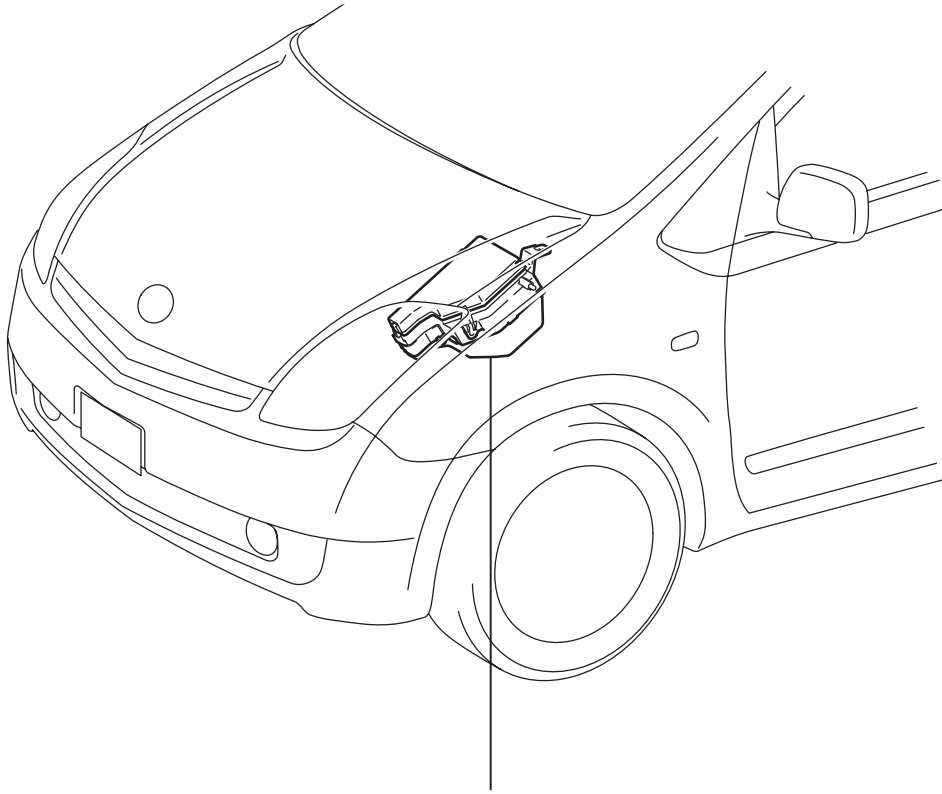

ENGINE ROOM JUNCTION BLOCK, RELAY BLOCK
- DOME FUSE

SYSTEM DIAGRAM

SB

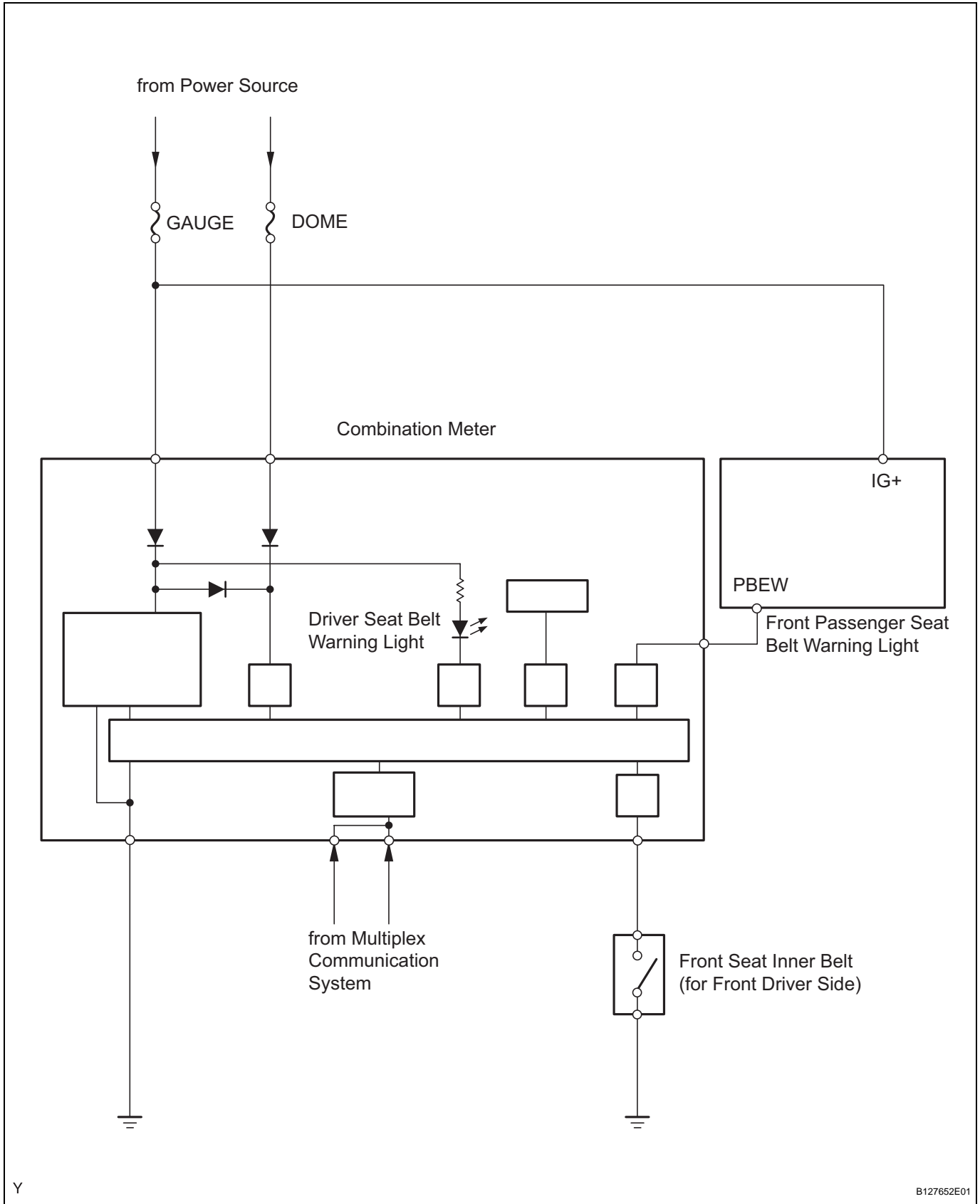

Y

SYSTEM DESCRIPTION

When the power switch is ON (IG) and the passenger or driver side seat belt is not fastened, the seat belt warning system repeatedly flashes the seat belt warning light. The system determines the seat belt status by checking if the seat belt buckle switch is OFF (seat belt fastened) or ON (seat belt unfastened).

PROBLEM SYMPTOMS TABLE

HINT:

Use the table below to help determine the cause of the problem symptom. The potential causes of the symptoms are listed in order of probability in the "Suspected area" column of the table. Check each symptom by checking the suspected areas in the order they are listed. Replace parts as necessary.

Seat belt warning system

Symptom	Suspected area	See page
Driver side seat belt warning light does not flash	1. DOME fuse	SB-1
	2. GAUGE fuse	SB-1
	3. Front seat inner belt (for driver side)	SB-6
	4. Combination meter	ME-36
	5. Wire harness	-
Driver side seat belt warning light does not illuminate	1. Front seat inner belt (for driver side)	SB-6
	2. Combination meter	ME-36
	3. Wire harness	-
Passenger side seat belt warning light does not flash	1. DOME fuse	SB-1
	2. GAUGE fuse	SB-1
	3. Combination meter	ME-38
	4. Front seat inner belt (for passenger side)	-
	5. Wire harness	-
Passenger side seat belt warning light does not illuminate	1. Combination meter	ME-38
	2. Front seat inner belt (for passenger side)	-
	3. Wire harness	-

FRONT SEAT INNER BELT ASSEMBLY

COMPONENTS

SB

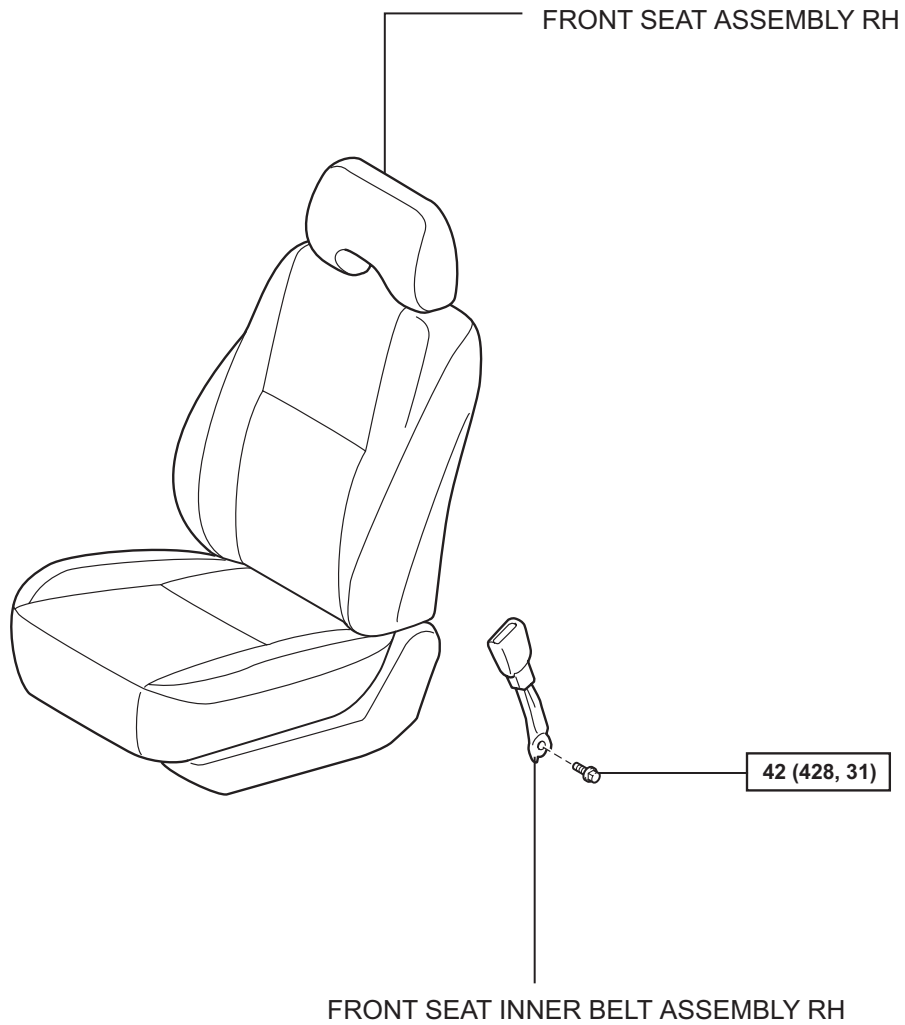

N*m (kgf*cm, ft.*lbf) : Specified torque

REMOVAL

HINT:

- Use the same procedures for the RH side and LH side.
- The procedures listed below are for the RH side.

1. DISCONNECT CABLE FROM NEGATIVE BATTERY TERMINAL

CAUTION:

Wait at least 90 seconds after disconnecting the cable from the negative (-) battery terminal to prevent airbag and seat belt pretensioner activation.

2. REMOVE FRONT SEAT ASSEMBLY RH (See page SE-4)

3. REMOVE FRONT SEAT INNER BELT ASSEMBLY RH

(a) Remove the bolt and inner belt.

INSPECTION

1. INSPECT FRONT SEAT INNER BELT ASSEMBLY (for Driver Side)

- (a) Measure the resistance of the buckle switch.

Standard resistance

Tester Connection	Condition	Specified Condition
1 - 2	Seat belt is unfastened	Below 1 Ω
1 - 2	Seat belt is fastened	1 M Ω or higher

If the result is not as specified, replace the belt assembly.

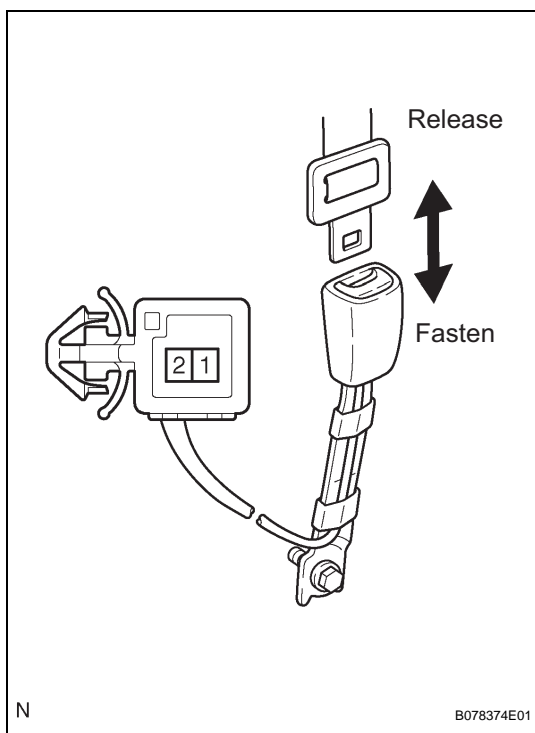

INSTALLATION

HINT:

- Use the same procedures for the RH side and LH side.
- The procedures listed below are for the RH side.

1. INSTALL FRONT SEAT INNER BELT ASSEMBLY RH

- (a) Install the inner belt with the bolt.

Torque: 42 N*m (428 kgf*cm, 31 ft.*lbf)

2. INSTALL FRONT SEAT ASSEMBLY RH (See page [SE-10](#))

3. CONNECT CABLE TO NEGATIVE BATTERY TERMINAL

4. PERFORM INITIALIZATION

- (a) Perform initialization (see page [IN-32](#)).

NOTICE:

Certain systems need to be initialized after disconnecting and reconnecting the cable from the negative (-) battery terminal.

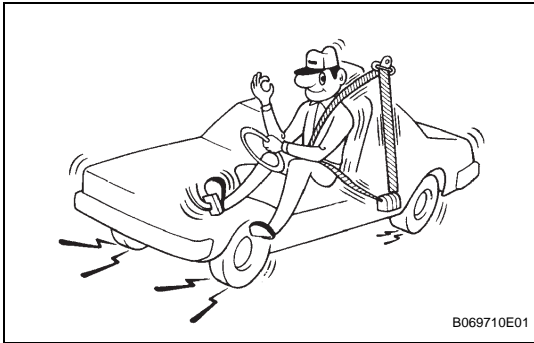

FRONT SEAT OUTER BELT ASSEMBLY

PRECAUTION

CAUTION:

Replace the faulty parts of the seat belt systems (outer belt, inner belt, bolts, nuts, adjustable shoulder anchor, tether anchor hardware and other related parts). When inspecting a vehicle that was in a collision, be sure to check all of the seat belt systems regardless of whether or not the system was activated in the collision. Replace any damaged or malfunctioning systems.

1. RUNNING TEST (IN SAFE AREA)

CAUTION:

Conduct this test in a safe area.

- (a) Fasten the front seat belt.
- (b) Drive the vehicle at 16 km/h (10 mph) and firmly depress the brake pedal. Check that the belts lock and cannot be extended at this time.
If a belt does not lock, replace the seat belt assembly (see page [SB-9](#)).

HINT:

Inspect a seat belt assembly before installing it (see page [SB-9](#)).

COMPONENTS

SB

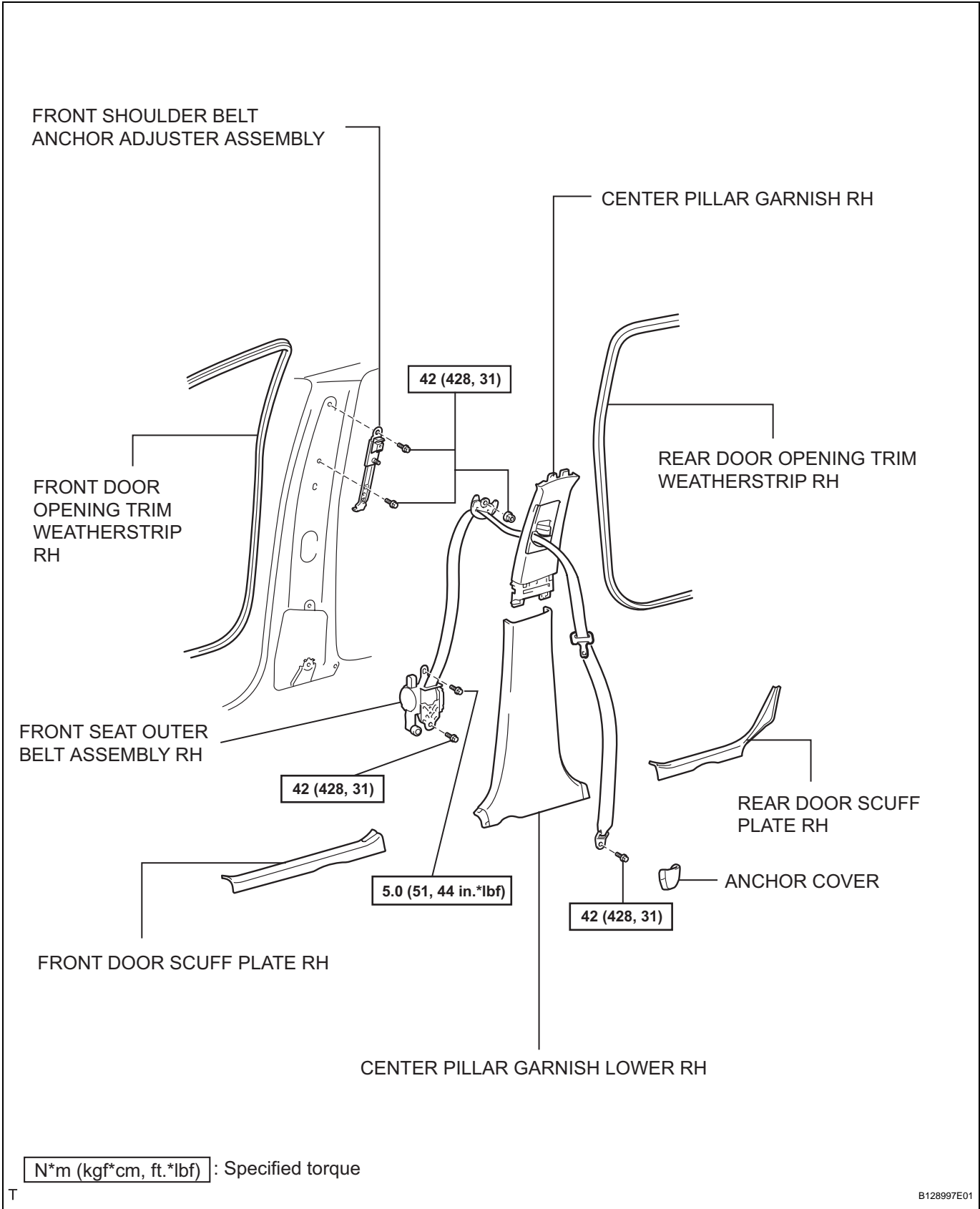

REMOVAL

HINT:

- Use the same procedures for the LH side and RH side.
- The procedures listed below are for the RH side.

1. DISCONNECT CABLE FROM NEGATIVE BATTERY TERMINAL

CAUTION:

Wait at least 90 seconds after disconnecting the cable from the negative (-) battery terminal to prevent airbag and seat belt pretensioner activation.

2. REMOVE FRONT DOOR SCUFF PLATE RH (See page IR-7)

3. REMOVE REAR DOOR SCUFF PLATE RH (See page IR-9)

4. REMOVE FRONT DOOR OPENING TRIM WEATHERSTRIP RH

5. REMOVE REAR DOOR OPENING TRIM WEATHERSTRIP RH

6. REMOVE CENTER PILLAR GARNISH LOWER RH (See page IR-9)

7. REMOVE CENTER PILLAR GARNISH RH (See page IR-10)

8. REMOVE FRONT SEAT OUTER BELT ASSEMBLY RH

- Remove the anchor cover and floor anchor bolt.
- Remove the nut and shoulder anchor.
- Disconnect the pretensioner connector.
- Remove the 2 bolts and outer belt.

9. REMOVE FRONT SHOULDER BELT ANCHOR ADJUSTER ASSEMBLY

- Remove the bolt and anchor adjuster.

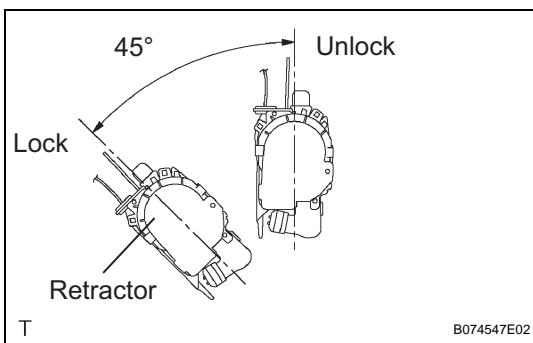
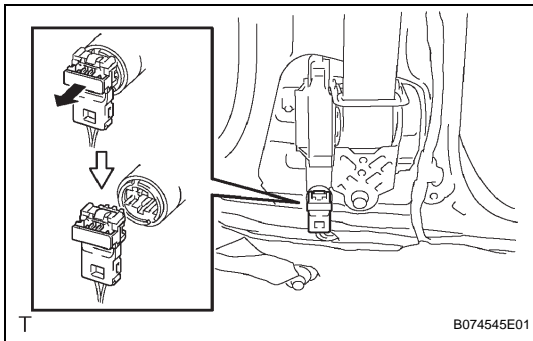

INSPECTION

1. INSPECT FRONT SEAT OUTER BELT ASSEMBLY

NOTICE:

Do not disassemble the retractor.

- Before installing the outer belt, check the ELR.
 - When the inclination of the retractor is 15° or less, check that the belt can be pulled from the retractor. When the inclination of the retractor is over 45°, check that the belt locks.

If the result is not as specified, replace the outer belt assembly.

INSTALLATION

HINT:

- Use the same procedures for the RH side and LH side.
- The procedures listed below are for the RH side.
- A bolt without a torque specification is shown in the standard bolt chart (see page [SS-2](#)).

1. INSTALL FRONT SHOULDER BELT ANCHOR ADJUSTER ASSEMBLY

- (a) Install the belt anchor adjuster with the bolt.
Torque: 42 N*m (428 kgf*cm, 31 ft.*lbf)

2. INSTALL FRONT SEAT OUTER BELT ASSEMBLY RH

- (a) Install the outer belt to the center pillar with the 2 bolts.
Torque: 5.0 N*m (51 kgf*cm, 44 in.*lbf) for upper bolt
42 N*m (428 kgf*cm, 31 ft.*lbf) for lower bolt

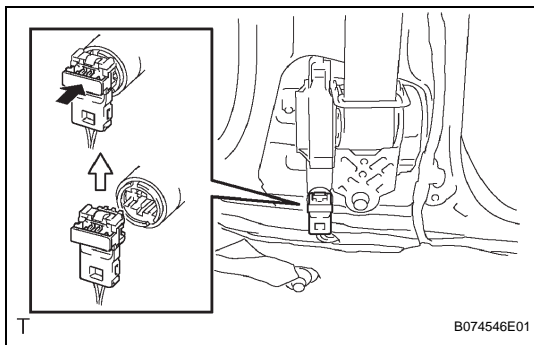

- (b) Connect the pretensioner connector as shown in the illustration.
- (c) Install the outer belt with the bolt on the shoulder anchor side.
Torque: 42 N*m (428 kgf*cm, 31 ft.*lbf)
- (d) Install the shoulder anchor cover.
- (e) Install the outer belt with the bolt on the floor anchor side.
Torque: 42 N*m (428 kgf*cm, 31 ft.*lbf)
- (f) Install the center pillar garnish RH (see page [IR-17](#)).
- (g) Install the center pillar lower garnish RH (see page [IR-17](#)).
- (h) Install the floor anchor to the floor panel with the bolt.
Torque: 42 N*m (428 kgf*cm, 31 ft.*lbf)
- (i) Install the front door scuff plate RH (see page [IR-19](#)).
- (j) Install the rear door scuff plate RH (see page [IR-18](#)).
- (k) Install the front door opening trim weatherstrip RH (see page [IR-19](#)).
- (l) Install the rear door opening trim weatherstrip RH (see page [IR-17](#)).
- (m) Check if the ELR locks.

NOTICE:

The check should be performed with the outer belt assembly installed.

- (1) With the belt installed, check that the belt locks when it is pulled out quickly.
 If the operation is not as specified, replace the outer belt assembly.

3. CONNECT CABLE TO NEGATIVE BATTERY TERMINAL

4. PERFORM INITIALIZATION

- (a) Perform initialization (see page [IN-32](#)).

NOTICE:

Certain systems need to be initialized after disconnecting and reconnecting the cable from the negative (-) battery terminal.

SB

DISPOSAL

HINT:

When scrapping vehicles equipped with a seat belt pretensioner or disposing of a front seat outer belt (with seat belt pretensioner), always first activate the seat belt pretensioner in accordance with the procedures described below. If any abnormality occurs during activation of the seat belt pretensioner, contact the SERVICE DEPARTMENT of TOYOTA MOTOR SALES, U.S.A., INC.

CAUTION:

- Never dispose of a front seat outer belt that has a non-activated pretensioner.
- The seat belt pretensioner produces a loud, exploding sound when it activates. Perform the operation where it will not be a nuisance to nearby people.
- When activating a front seat outer belt (with seat belt pretensioner), stand at least 10 m (33 ft.) away from the front seat outer belt.
- Use gloves and safety glasses when handling a front seat outer belt with an activated pretensioner.
- Always wash your hands with water after completing the disposal.
- Do not apply water to a front seat outer belt that has an activated pretensioner.
- Perform procedures in a place away from electrical interference.
- When activating the seat belt pretensioner, always use the specified SST (SRS airbag deployment tool).

1. DISPOSE OF FRONT SEAT OUTER BELT ASSEMBLY RH (WHEN INSTALLED IN VEHICLE)

HINT:

Prepare a battery to activate the seat belt pretensioner.

- (a) Check if SST is functioning properly.

SST 09082-00700

CAUTION:

When activating the seat belt pretensioner, always use the specified SST.

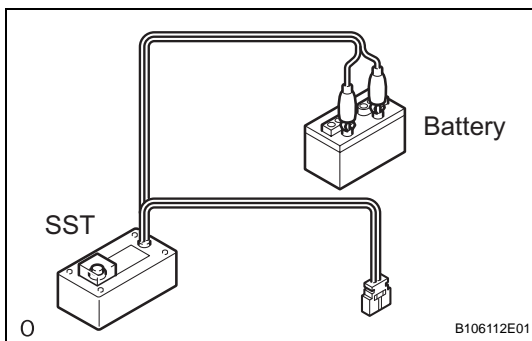
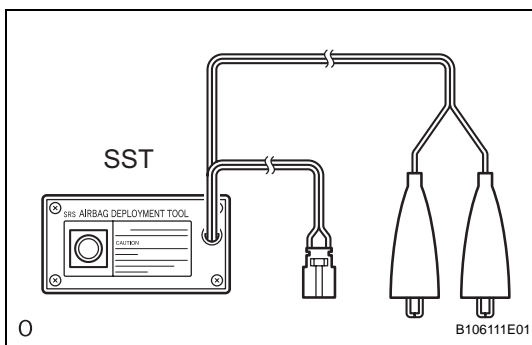
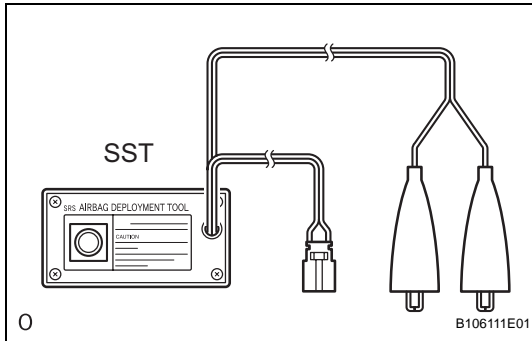

- (1) Connect the SST's red clip to the battery's positive (+) terminal and the black clip to the battery's negative (-) terminal.

HINT:

Do not connect the yellow connector. The yellow connector is used to connect to the seat belt pretensioner.

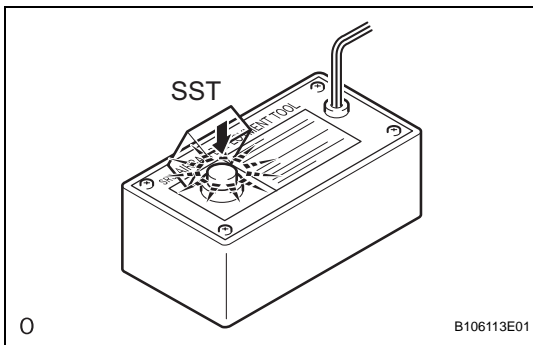

- (2) Press the SST activation switch and check that the LED of the SST activation switch illuminates.

CAUTION:

If the LED illuminates when the activation switch is not being pressed, SST may be malfunctioning. Replace SST with a new one.

- (b) Disconnect SST from the battery.
- (c) Disconnect the pretensioner connector.
 - (1) Disconnect the cable from the negative (-) battery terminal.
 - (2) Remove the front door scuff plate RH (see page [IR-7](#)).
 - (3) Remove the rear door scuff plate RH (see page [IR-9](#)).
 - (4) Remove the front door opening trim weatherstrip RH (see page [IR-7](#)).
 - (5) Remove the rear door opening trim weatherstrip RH (see page [IR-9](#)).
 - (6) Remove the center pillar garnish lower RH (see page [IR-9](#)).
 - (7) Remove the center pillar garnish upper RH (see page [IR-10](#)).
 - (8) Disconnect the pretensioner connector as shown in the illustration.
- (d) Prepare SST for activation of the seat belt pretensioner.
 - (1) Install the floor anchor of the seat belt.

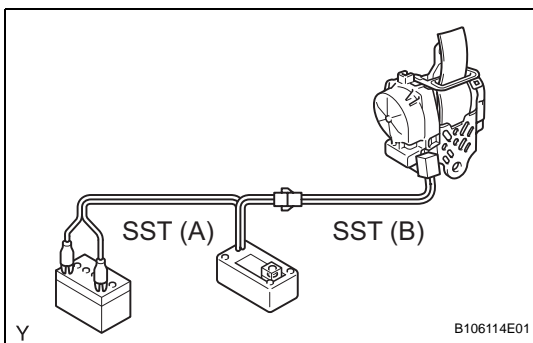
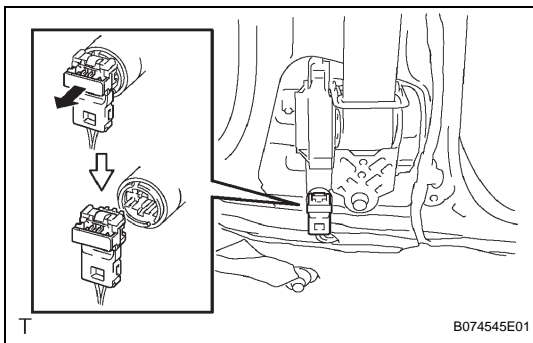

- (2) Connect SST (A) to SST (B). Then connect the SST (B)'s connector to the seat belt pretensioner.

SST 09082-00700, 09082-00770

NOTICE:

To avoid damaging the SST connector and wire harness, do not lock the secondary lock of the twin lock.

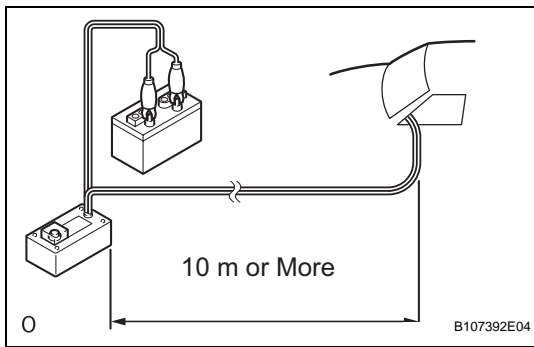

SB

- (3) Move SST at least 10 m (33 ft.) away from the front of the vehicle.
 - (4) Close all the doors and windows of the vehicle.
HINT:
Leave a gap in one of the windows for inserting the SST wire harness.
NOTICE:
Take care not to damage the SST wire harness.
 - (5) Connect the SST's red clip to the battery's positive (+) terminal and the black clip to the negative (-) terminal.
- (e) Activate the seat belt pretensioner.
- (1) Confirm that no one is inside the vehicle or within 10 m (33 ft.) of the vehicle.
 - (2) Press the SST activation switch to activate the seat belt pretensioner.
HINT:
The seat belt pretensioner operates at the same time the SST activation switch's LED illuminates.
- (f) Dispose of the front seat outer belt (with the seat belt pretensioner).
CAUTION:
- **Do not touch the front seat outer belt for at least 30 minutes after the seat belt pretensioner has been activated. It is very hot.**
 - **Use gloves and safety glasses when handling a front seat outer belt whose pretensioner has been activated.**
 - **Always wash your hands with water after completing the disposal.**
 - **Do not apply water to a front seat outer belt that has an activated pretensioner.**
- HINT:
When scrapping a vehicle, activate the seat belt pretensioner, and then scrap the vehicle with the activated front seat outer belt installed.
2. **DISPOSE OF FRONT SEAT OUTER BELT ASSEMBLY (WHEN NOT INSTALLED IN VEHICLE)**
NOTICE:
- **When only disposing of the front seat outer belt (with the seat belt pretensioner), never use the customer's vehicle to activate the seat belt pretensioner.**
 - **Be sure to follow the procedures listed below when activating the seat belt pretensioner.**

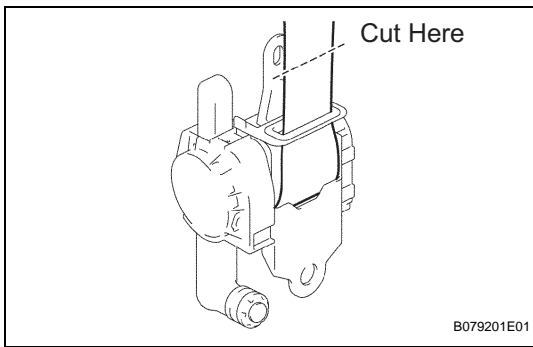

- (a) Remove the front seat outer belt.
- (1) Wind the seat belt with the retractor.
 - (2) When the seat belt is sufficiently wound, cut the seat belt approximately 100 mm (0.39 in.) from the retractor, as shown in the illustration.

HINT:

The seat belt is designed so that winding the seat belt before pretensioner activation will decrease the pulling power of the seat belt during pretensioner activation.

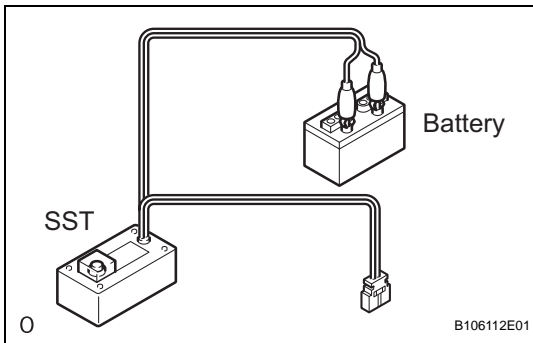

- (b) Check if SST is functioning properly.

SST 09082-00700, 09082-00770

CAUTION:

When activating a seat belt pretensioner, always use the specified SST.

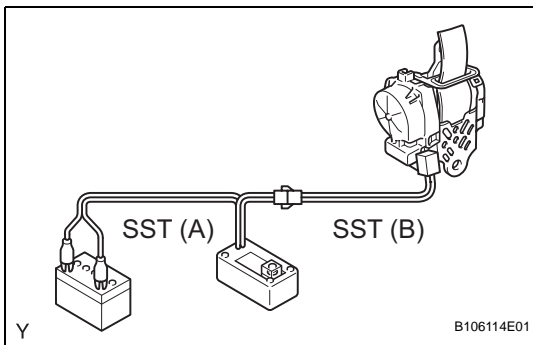

- (c) Prepare SST for activation of the seat belt pretensioner.

- (1) Connect SST (A) to SST (B). Then connect the SST (B)'s connector to the seat belt pretensioner.

NOTICE:

To avoid damaging the SST connector and wire harness, do not lock the secondary lock of the twin lock.

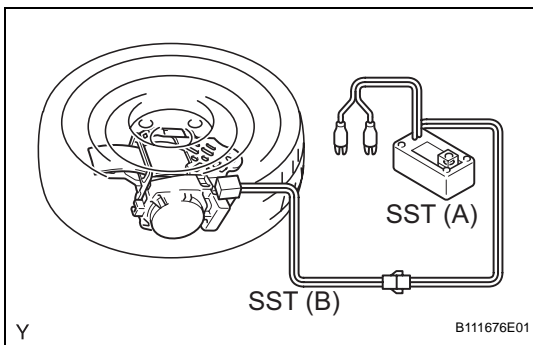

- (2) Place the front seat outer belt on the ground and cover it with a tire (with wheel).

NOTICE:

Set up the front seat outer belt as shown in the illustration.

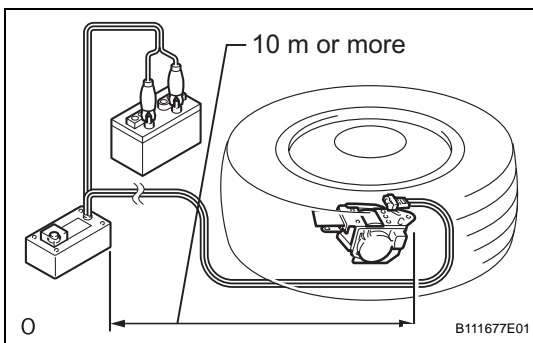

- (3) Move SST at least 10 m (33 ft.) away from the wheel.

NOTICE:

Take care not to damage the SST wire harness.

- (d) Activate the seat belt pretensioner.

- (1) Connect the SST's red clip to the battery's positive (+) terminal and the black clip to the battery's negative (-) terminal.
- (2) Check that no one is within 10 m (33 ft.) of the wheel.

- (3) Press the SST activation switch to activate the seat belt pretensioner.

HINT:

The seat belt pretensioner operates at the same time the SST activation switch's LED illuminates.

- (e) Dispose of the front seat outer belt (with the seat belt pretensioner).

CAUTION:

- **Do not touch the front seat outer belt for at least 30 minutes after the seat belt pretensioner has been activated. It is very hot.**
- **Use gloves and safety glasses when handling a front seat outer belt whose pretensioner has been activated.**
- **Always wash your hands with water after completing the disposal.**
- **Do not apply water to a front seat outer belt that has an activated pretensioner.**

- (1) Remove the tire (with wheel) and SST.

- (2) Place the front seat outer belt in a plastic bag, tie the end tightly and dispose of it in the same way as other general parts.

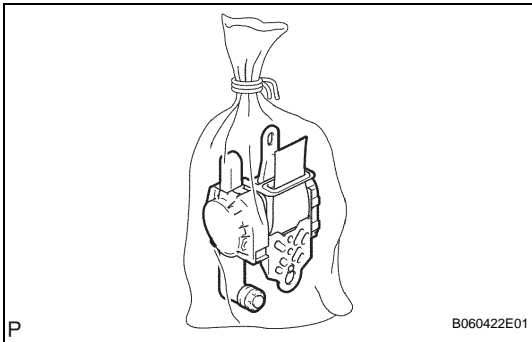

REAR SEAT INNER BELT ASSEMBLY

COMPONENTS

SB

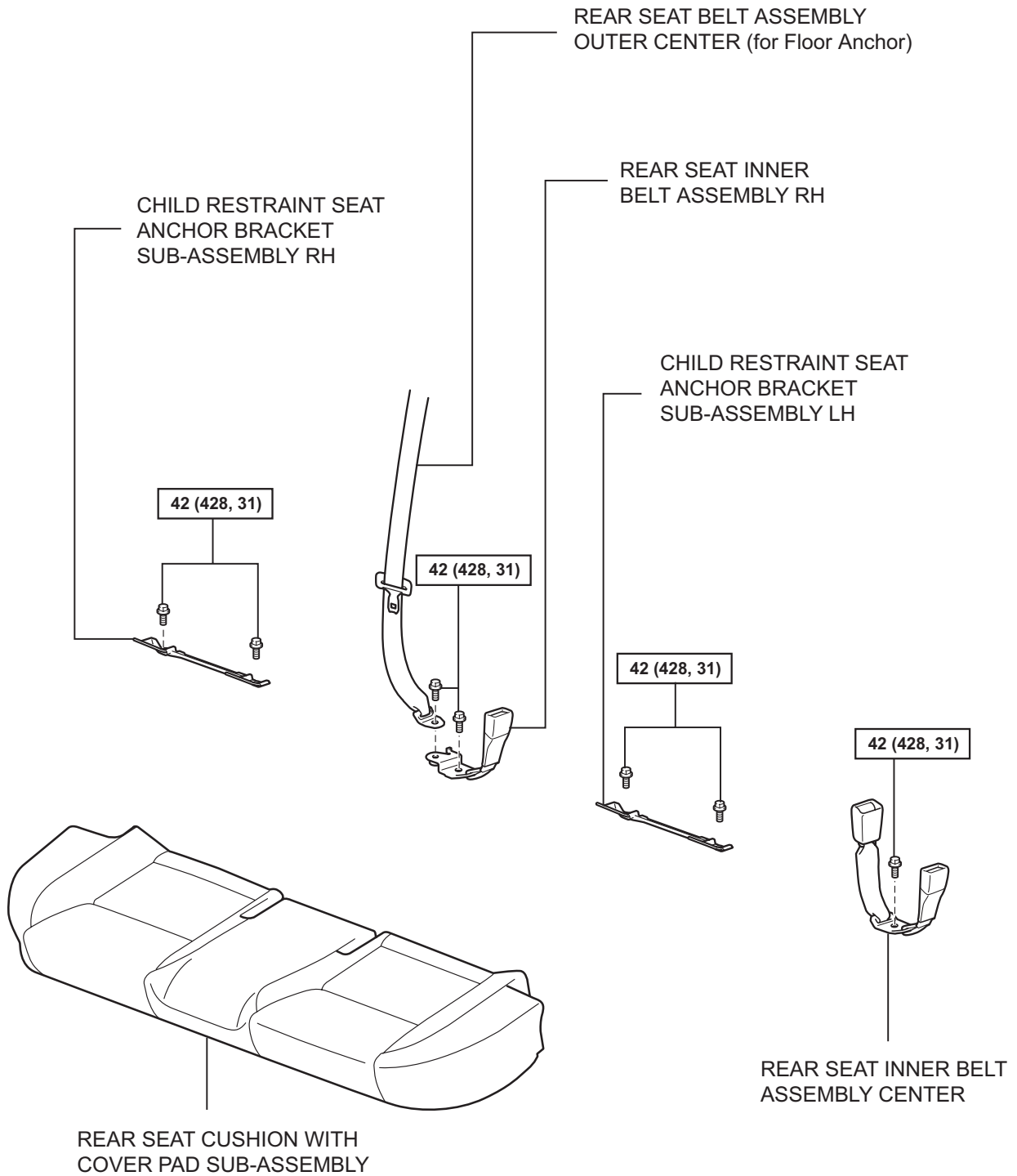

N*m (kgf*cm, ft.*lbf) : Specified torque

REMOVAL

1. REMOVE REAR SEAT CUSHION ASSEMBLY (See page SE-15)
2. DISCONNECT REAR SEAT BELT ASSEMBLY OUTER CENTER (for Floor Anchor)

(a) Remove the bolt and floor anchor part of the seat belt outer.

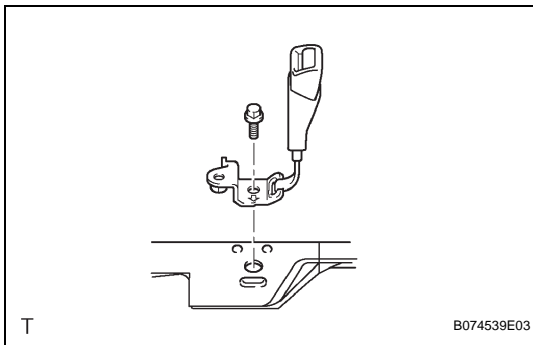
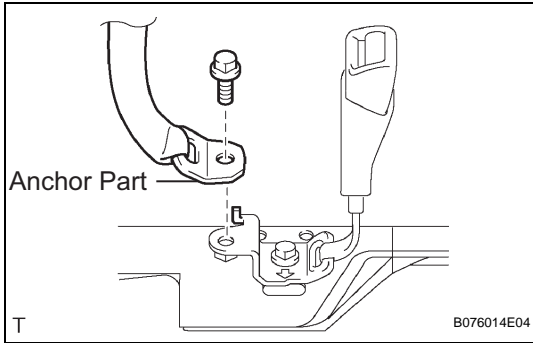

3. REMOVE REAR SEAT INNER BELT ASSEMBLY RH
 - (a) Remove the bolt and rear seat inner belt.

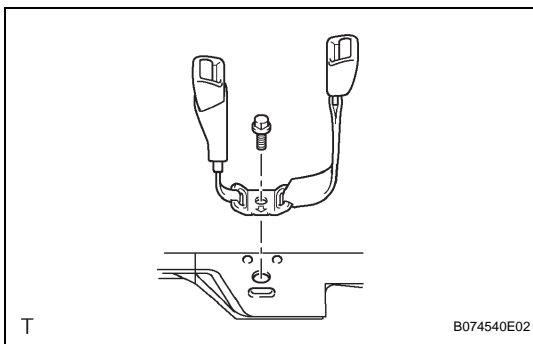

4. REMOVE REAR SEAT INNER BELT ASSEMBLY CENTER
 - (a) Remove the bolt and rear seat inner belt.
5. REMOVE CHILD RESTRAINT SEAT ANCHOR BRACKET SUB-ASSEMBLY LH
 - (a) Remove the 2 bolts and anchor bracket.
6. REMOVE CHILD RESTRAINT SEAT ANCHOR BRACKET SUB-ASSEMBLY RH
 - Remove the 2 bolts and anchor bracket.

INSTALLATION

HINT:

A bolt without a torque specification is shown in the standard bolt chart (see page [SS-2](#)).

1. INSTALL CHILD RESTRAINT SEAT ANCHOR BRACKET SUB-ASSEMBLY LH

- (a) Install the anchor bracket with the 2 bolts.
Torque: 42 N*m (428 kgf*cm, 31 ft.*lbf)

2. INSTALL CHILD RESTRAINT SEAT ANCHOR BRACKET SUB-ASSEMBLY RH

- (a) Install the anchor bracket with the 2 bolts.
Torque: 42 N*m (428 kgf*cm, 31 ft.*lbf)

3. INSTALL REAR SEAT INNER BELT ASSEMBLY CENTER

- (a) Install the rear seat inner belt with the bolt, as shown in the illustration.

Torque: 42 N*m (428 kgf*cm, 31 ft.*lbf)

NOTICE:

Make sure that the anchor part does not run onto the protruding part of the floor panel.

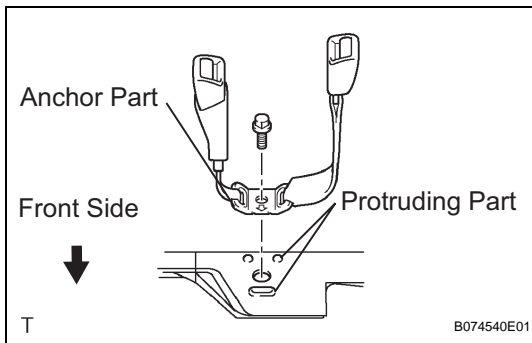

4. INSTALL REAR SEAT INNER BELT ASSEMBLY RH

- (a) Install the rear seat inner belt with the bolt, as shown in the illustration.

Torque: 42 N*m (428 kgf*cm, 31 ft.*lbf)

NOTICE:

Make sure that the anchor part does not run onto the protruding part of the floor panel.

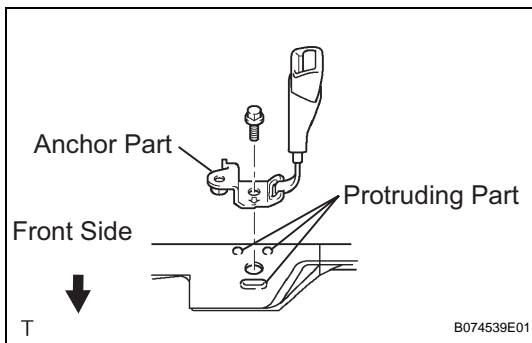

5. CONNECT REAR SEAT BELT ASSEMBLY OUTER CENTER (for Floor Anchor)

- (a) Install the floor anchor part of the rear seat inner belt with the bolt, as shown in the illustration.

Torque: 42 N*m (428 kgf*cm, 31 ft.*lbf)

NOTICE:

Make sure that the anchor part does not run onto the protruding part.

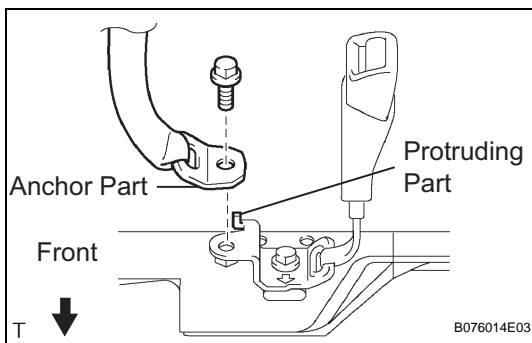

6. INSTALL REAR SEAT CUSHION ASSEMBLY (See page [SE-23](#))

REAR SEAT OUTER BELT ASSEMBLY

COMPONENTS

SB

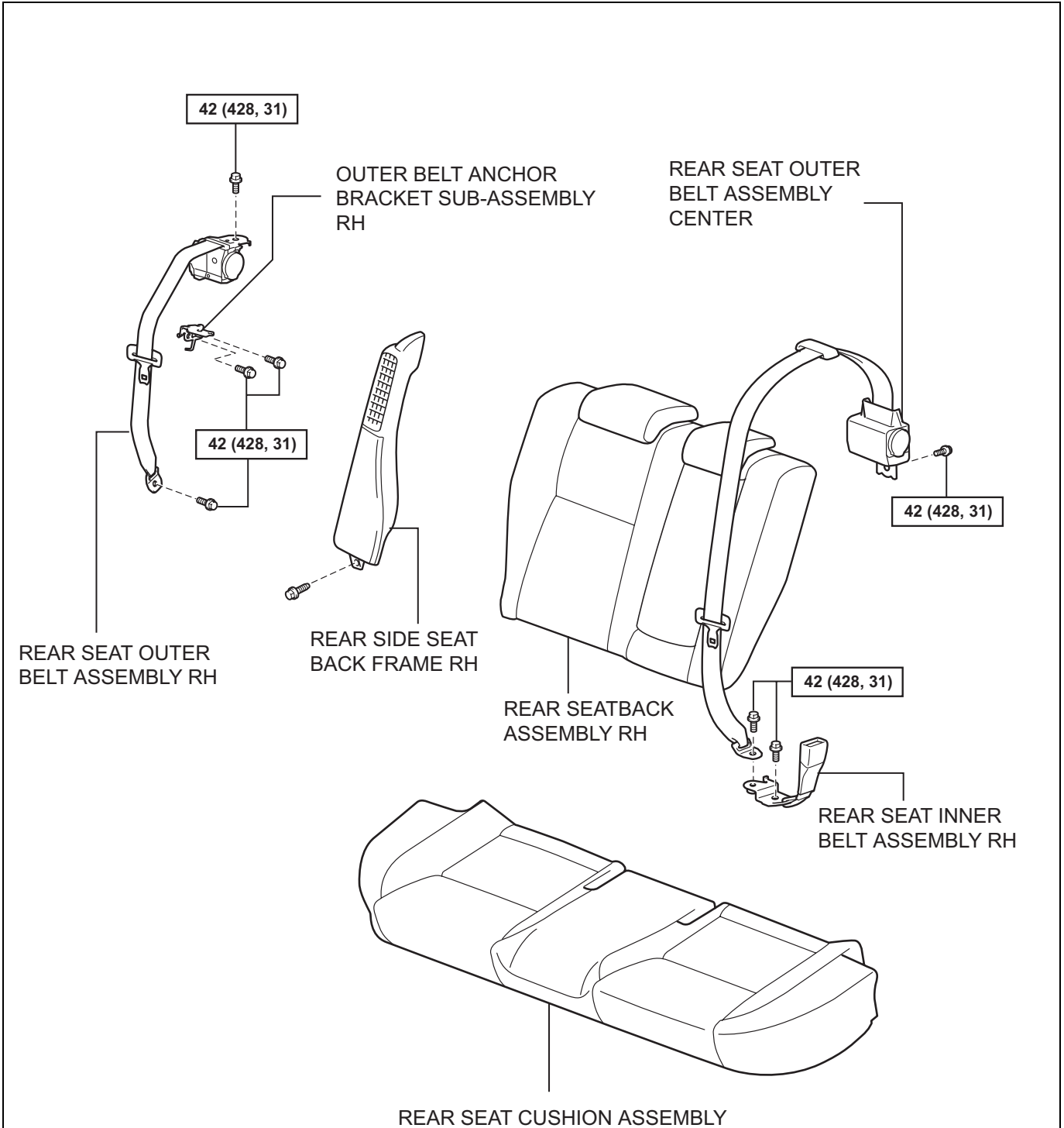

N*m (kgf*cm, ft.*lbf) : Specified torque

T

SB

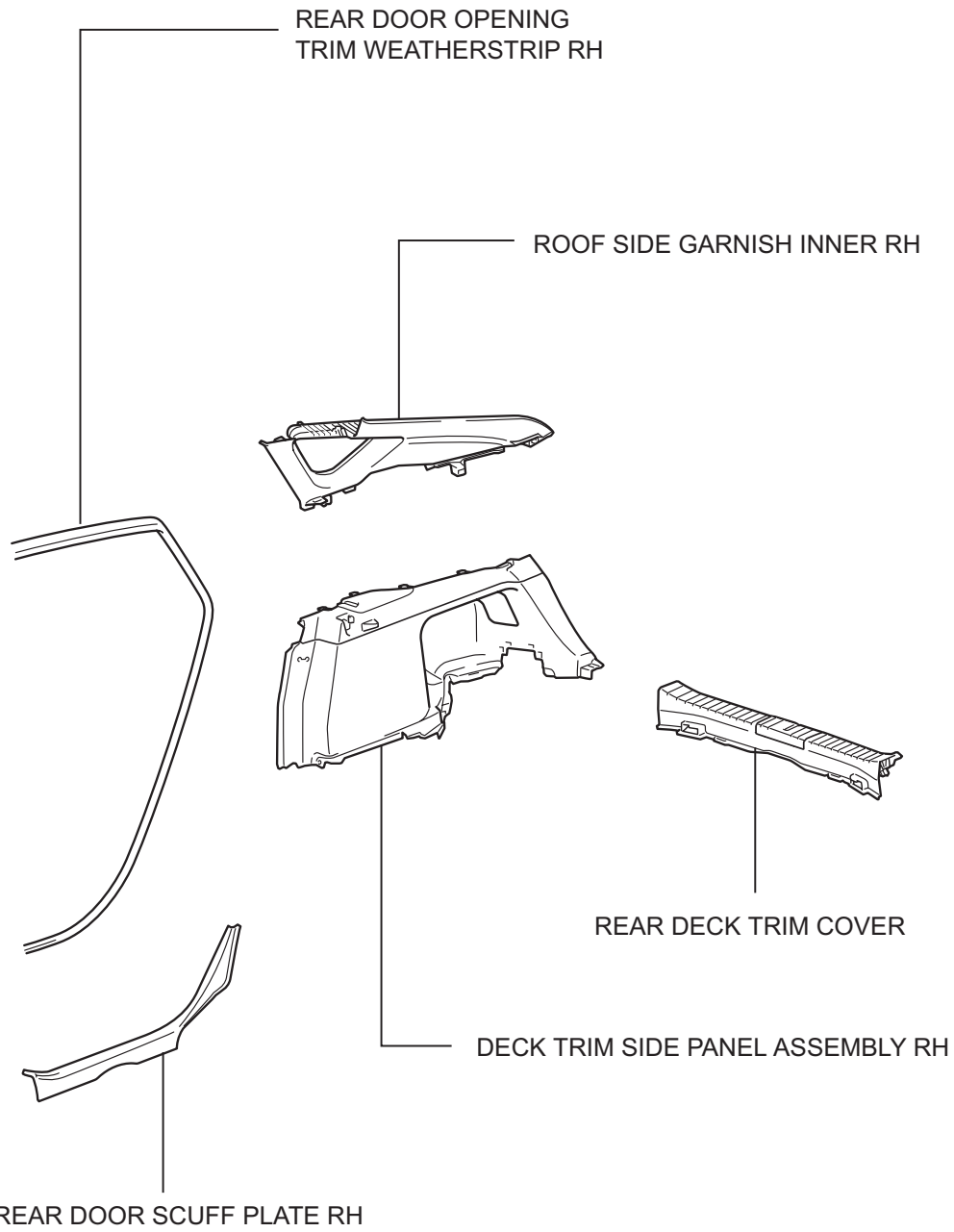

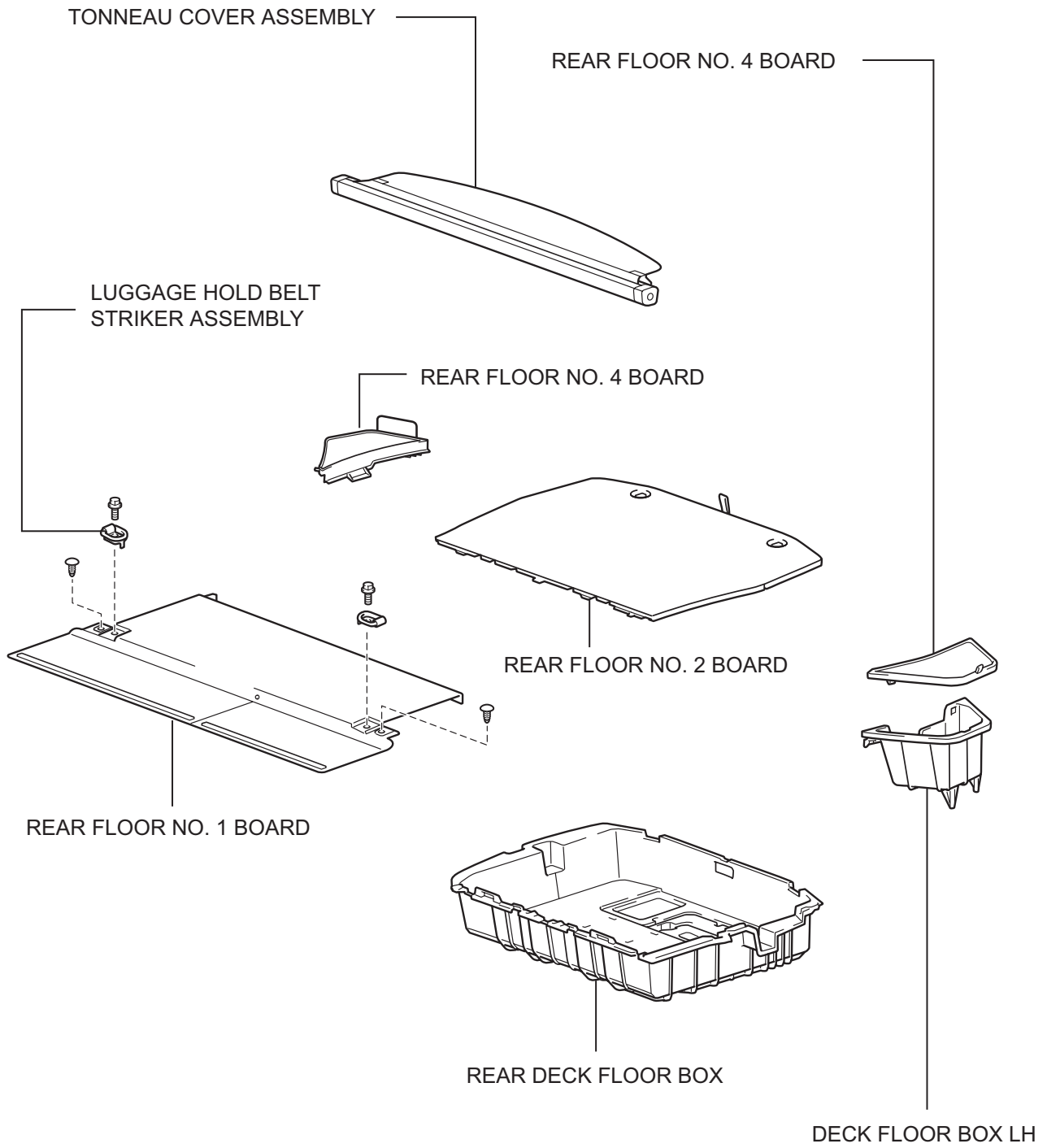

REMOVAL

HINT:

- Use the same procedures for the RH side and LH side.
- The procedures listed below are for the RH side.

1. DISCONNECT CABLE FROM NEGATIVE BATTERY TERMINAL

CAUTION:

Wait at least 90 seconds after disconnecting the cable from the negative (-) battery terminal to prevent airbag and seat belt pretensioner activation.

2. REMOVE REAR SEAT CUSHION ASSEMBLY (See page [SE-15](#))
3. REMOVE REAR DOOR SCUFF PLATE RH (See page [IR-9](#))
4. REMOVE REAR SIDE SEAT BACK FRAME RH (See page [SE-15](#))
5. REMOVE REAR DOOR OPENING TRIM WEATHERSTRIP RH
6. REMOVE REAR SEAT BACK ASSEMBLY RH (See page [SE-15](#))
7. REMOVE REAR SEAT BACK ASSEMBLY RH (See page [SE-15](#))
8. REMOVE TONNEAU COVER ASSEMBLY
9. REMOVE REAR FLOOR NO. 2 BOARD
10. REMOVE REAR FLOOR NO. 1 BOARD
11. REMOVE REAR FLOOR NO. 4 BOARD
12. REMOVE DECK FLOOR BOX LH
13. REMOVE REAR DECK FLOOR BOX
14. REMOVE REAR DECK TRIM COVER (See page [IR-10](#))
15. REMOVE DECK TRIM SIDE PANEL ASSEMBLY RH (See page [IR-11](#))
16. REMOVE ROOF SIDE GARNISH INNER RH (See page [IR-11](#))
17. REMOVE REAR SEAT OUTER BELT ASSEMBLY RH
 - (a) Remove the 2 bolts and outer belt.
 - (b) Remove the 2 bolts and belt outer anchor bracket RH.
18. REMOVE REAR SEAT OUTER BELT ASSEMBLY CENTER

HINT:

RH side only.

- (a) Remove the bolt and disconnect the floor anchor.

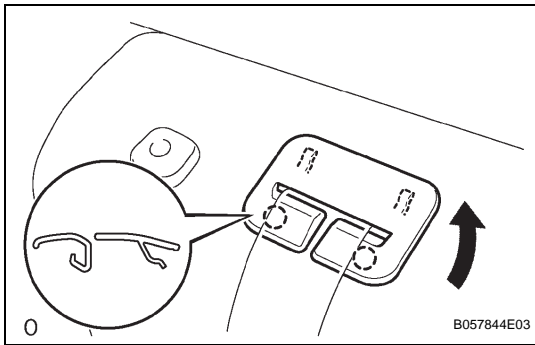

- (b) Using a screwdriver, detach the 4 claws and remove the cover.

HINT:

Tape the screwdriver tip before use.

- (c) Remove the rear seat headrest RH (see page [SE-16](#)).
- (d) Remove the rear seat center headrest (see page [SE-16](#)).
- (e) Remove the rear seat back cover RH (see page [SE-17](#)).
- (f) Remove the bolt on the retractor side and belt.

INSPECTION

1. INSPECT REAR SEAT OUTER BELT ASSEMBLY CENTER

NOTICE:

Do not disassemble the retractor.

- (a) When the inclination of the retractor is 15° or less, check that the belt can be pulled from the retractor. When the inclination of the retractor is over 45° , check that the belt locks. If the operation is not as specified, replace the belt.

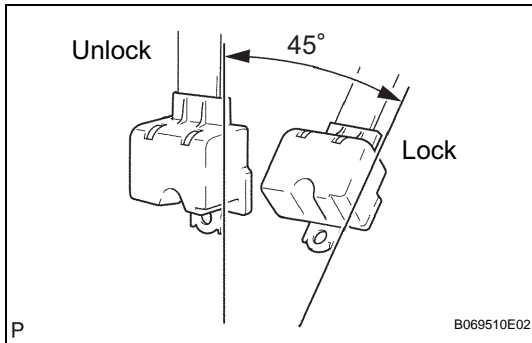

2. INSPECT REAR SEAT OUTER BELT ASSEMBLY

NOTICE:

Do not disassemble the retractor.

- (a) When the inclination of the retractor is 15° or less, check that the belt can be pulled from the retractor. When the inclination of the retractor is over 45° , check that the belt locks. If the operation is not as specified, replace the belt.

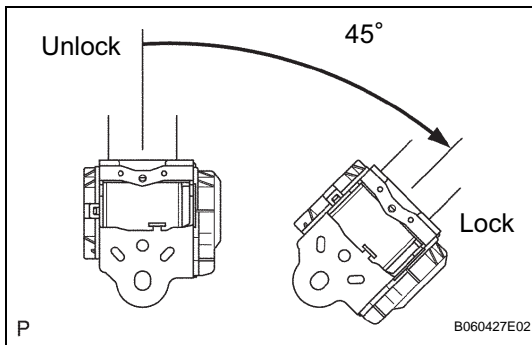

INSTALLATION

HINT:

- Use the same procedures for the RH side and LH side.
- The procedures listed below are for the LH side.
- A bolt without a torque specification is shown in the standard bolt chart (see page [SS-2](#)).

1. INSTALL REAR SEAT OUTER BELT ASSEMBLY CENTER

- Install the belt with the bolt on the retractor side.
Torque: 42 N*m (428 kgf*cm, 31 ft.*lbf)
- Install the rear seatback cover RH (see page [SE-20](#)).
- Install the rear seat headrest RH (see page [SE-21](#)).
- Install the rear seat center headrest (see page [SE-21](#)).
- Attach the 4 claws to install the cover (see page [SE-22](#)).
- Connect the floor anchor of the belt with the bolt, as shown in the illustration.

Torque: 42 N*m (428 kgf*cm, 31 ft.*lbf)

NOTICE:

Make sure that the anchor part does not run onto the protruding part.

2. INSTALL REAR SEAT OUTER BELT ASSEMBLY RH

- Install the belt on the retractor side with the bolt.
Torque: 42 N*m (428 kgf*cm, 31 ft.*lbf)
- Install the belt on the floor anchor side with the bolt.
Torque: 42 N*m (428 kgf*cm, 31 ft.*lbf)
- With the belt installed, check that the belt locks when it is pulled out quickly.

NOTICE:

The check should be performed with the outer belt installed.

If the operation is not as specified, replace the belt.

3. INSTALL ROOF SIDE GARNISH INNER RH (See page [IR-15](#))

4. INSTALL DECK TRIM SIDE PANEL ASSEMBLY RH

- Install the deck trim side panel RH (see page [IR-16](#)).
- Install the rear seat outer belt RH with the bolt on the floor anchor side.

Torque: 42 N*m (428 kgf*cm, 31 ft.*lbf)

5. INSTALL REAR DECK TRIM COVER (See page [IR-16](#))

6. INSTALL REAR DECK FLOOR BOX

7. INSTALL DECK FLOOR BOX LH

8. INSTALL REAR FLOOR NO. 4 BOARD

9. INSTALL REAR FLOOR NO. 1 BOARD

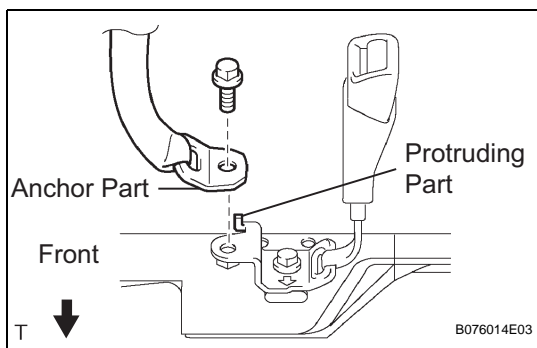

SB

10. INSTALL REAR FLOOR NO. 2 BOARD
11. INSTALL TONNEAU COVER ASSEMBLY
12. INSTALL REAR SEAT BACK ASSEMBLY RH (See page [SE-23](#))
13. INSTALL REAR DOOR OPENING TRIM WEATHERSTRIP RH
14. INSTALL REAR SIDE SEAT BACK FRAME RH
15. INSTALL REAR DOOR SCUFF PLATE RH
16. INSTALL REAR SEAT CUSHION ASSEMBLY (See page [SE-23](#))
17. CONNECT CABLE TO NEGATIVE BATTERY TERMINAL
18. PERFORM INITIALIZATION
 - (a) Perform initialization (see page [IN-32](#)).

NOTICE:
Certain systems need to be initialized after disconnecting and reconnecting the cable from the negative (-) battery terminal.