

SUSPENSION SYSTEM

PROBLEM SYMPTOMS TABLE

HINT:

Use the table below to help determine the cause of the problem symptom. The potential causes of the symptoms are listed in order of probability in the "Suspected area" column of the table. Check each symptom by checking the suspected areas in the order they are listed. Replace parts as necessary.

Suspension system

Symptom	Suspected area	See page
Vehicle is unstable	1. Tires (worn or improperly inflated)	TW-3
	2. Front wheel alignment	SP-2
	3. Rear wheel alignment	SP-10
	4. Front hub bearing	AH-4
	5. Rear hub bearing	AH-10
	6. Front shock absorber with coil spring	SP-14
	7. Rear shock absorber with coil spring	SP-33
Bottoming	1. Vehicle (overloaded)	-
	2. Front shock absorber with coil spring	SP-14
	3. Rear shock absorber with coil spring	SP-33
Sways/pitches	1. Tire (worn or improperly inflated)	TW-3
	2. Front stabilizer bar	SP-29
	3. Rear stabilizer bar	SP-45
	4. Front shock absorber with coil spring	SP-14
	5. Rear shock absorber with coil spring	SP-33
Wheels shimmy	1. Tire (worn or improperly inflated)	TW-3
	2. Wheels (out of balance)	TW-3
	3. Front wheel alignment	SP-2
	4. Rear wheel alignment	SP-10
	5. Front suspension lower No. 1 arm sub-assy	SP-20
	6. Front lower ball joint assembly	SP-24
	7. Rear axle beam	SP-38
	8. Front shock absorber with coil spring	SP-14
	9. Rear shock absorber with coil spring	SP-14
	10. Front hub bearing	AH-4
	11. Rear hub bearing	AH-10
Abnormal tire wear	1. Tire (worn or improperly inflated)	TW-3
	2. Wheels (out of balance)	TW-3
	3. Front wheel alignment	SP-2
	4. Rear wheel alignment	SP-10
Vehicle pull	1. Tire	TW-3
	2. Tire pressure (incorrect)	TW-3
	3. Front wheel alignment (incorrect)	SP-2
	4. Rear wheel alignment (incorrect)	SP-10
	5. Brake (dragging)	-
	6. Steering wheel (off center)	-

FRONT WHEEL ALIGNMENT

ADJUSTMENT

1. **INSPECT TIRE**
 - (a) Inspect the tires (see page [TW-3](#)).
2. **MEASURE VEHICLE HEIGHT**
Standard vehicle height

Item	Specified Condition
Front (A - B)	95 mm (3.74 in.)
Rear (D - C)	62 mm (2.44 in.)

Measuring points:

- A:**
Ground clearance of front wheel center
- B:**
Ground clearance of lower arm No. 1 set bolt center
- C:**
Ground clearance of rear axle carrier bush set bolt center
- D:**
Ground clearance of rear wheel center

NOTICE:

Before inspecting the wheel alignment, adjust the vehicle height to the specified value.

HINT:

Bounce the vehicle at the corners up and down to stabilize the suspension and inspect the vehicle height.

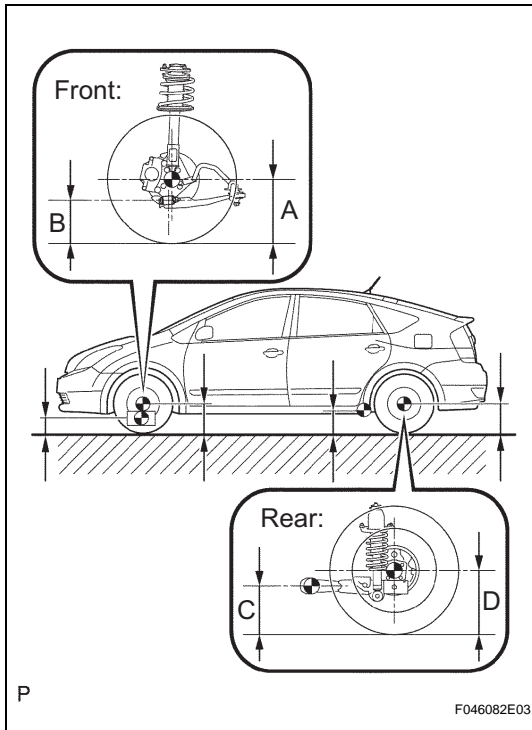

3. **INSPECT TOE-IN**
Standard toe-in

Item	Specified Condition
Toe-in (total)	A + B: 0° +12' (0° +0.2°) C - D: 0 +2 mm (0 +0.08 in.)

HINT:

- Measure "C - D" only when "A + B" cannot be measured.
- If the toe-in is not within the specified range, adjust it at the rack ends.

4. **ADJUST TOE-IN**

- (a) Measure the thread lengths of the right and left rack ends.

**Standard difference in thread length:
1.5 mm (0.059 in.) or less**

- (b) Remove the rack boot set clips.
- (c) Loosen the tie rod end lock nuts.
- (d) Adjust the rack ends if the difference in thread length between the right and left rack ends is not within the specified range.
 - (1) Extend the shorter rack end if the measured toe-in deviates toward the outer-side.
 - (2) Shorten the longer rack end if the measured toe-in deviates toward the inner-side.

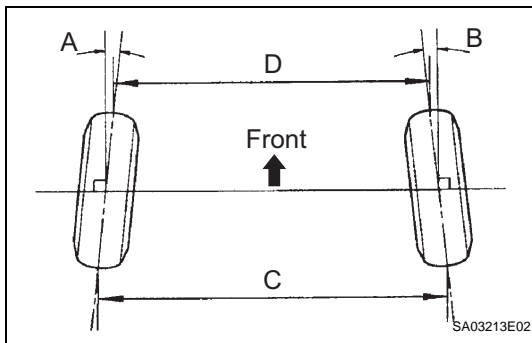

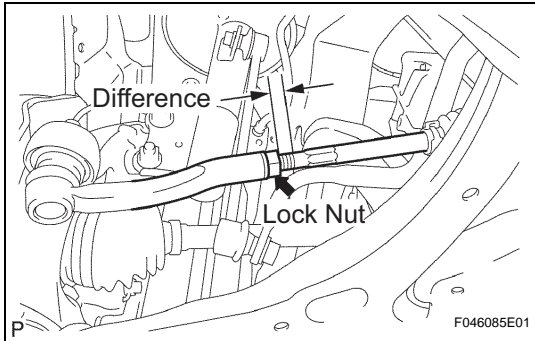

- (e) Turn the right and left rack ends by an equal amount to adjust toe-in.
HINT:
Try to adjust toe-in to the center of the specified range.

- (f) Make sure that the lengths of the right and left rack ends are the same.

Standard :
0 +-1 mm (0.0039 in.)

- (g) Torque the tie rod end lock nuts.
Torque: 74 N*m (755 kgf*cm, 55 ft.*lbf)

NOTICE:
Temporarily tighten the lock nut while holding the hexagonal part of the steering rack end so that the lock nut and the steering rack end do not turn together. Hold the width across the flat part of the tie rod end and tighten the lock nut.

- (h) Place the boots on the seats and install the clips.
HINT:
Make sure that the boots are not twisted.
- (i) Perform VSC system calibration (see page [BC-21](#)).

5. INSPECT WHEEL ANGLE

- (a) Fully turn the steering wheel to the left and right and measure the turning angle.

Standard wheel turning angle

Item	Specified Condition
Inside wheel	40° 35' +-2° (40.58° +-2°)
Outside wheel: Reference	34° 15' (34.25°)

If the right and left inside wheel angles differ from the specified range, check the right and left rack end lengths.

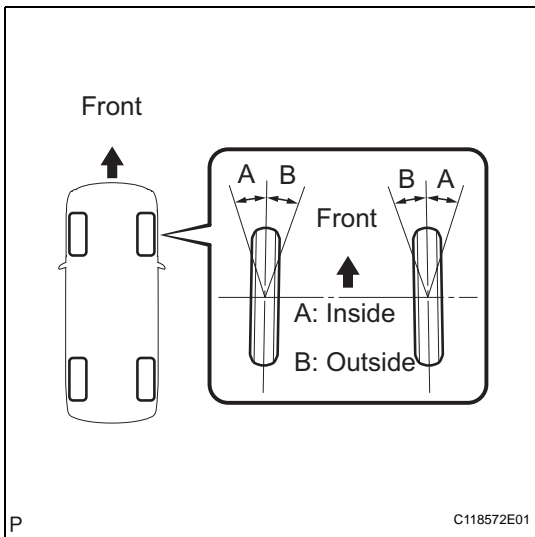

6. INSPECT CAMBER, CASTER AND STEERING AXIS INCLINATION

- (a) Put the front wheel on the center of the alignment tester.
- (b) Remove the center ornament.
- (c) Install the camber-caster-steering axis inclination gauge at the center of the axle hub or drive shaft.
- (d) Inspect the camber, caster and steering axis inclination.

Standard camber, caster and steering axis inclination

Item	Specified Condition
Camber Right-left error	-0° 35' +-45' (-0.58° +-0.75°) 45' (0.75°) or less
Caster Right-left error	3° 10' +-45' (3.17° +-0.75°) 45' (0.75°) or less

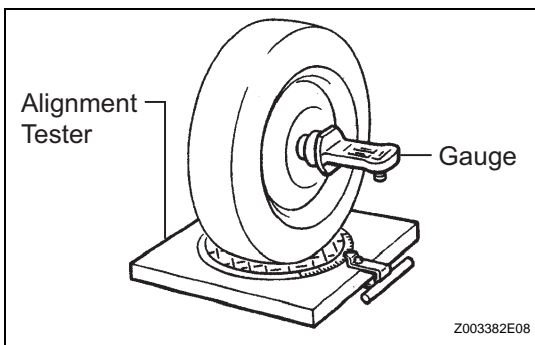

Item	Specified Condition
Steering axis inclination	12° 35' +45' (12.58° +-0.75°)
Right-left error	45' (0.75°) or less

NOTICE:

- Inspect with an empty vehicle (without the spare tire or tools).
 - The maximum tolerance of the right and left difference for the camber and caster is 45' or less.
- (e) Remove the camber-caster-steering axis inclination gauge and attachment.
- (f) Install the center ornament.
If the caster and steering axis inclination are not within the specified values after the camber has been correctly adjusted, recheck the suspension parts for damage and/or wear.

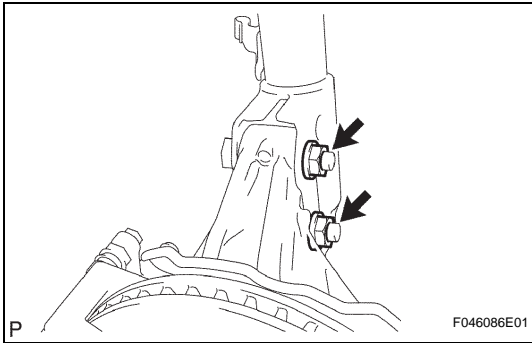

7. ADJUST CAMBER

NOTICE:

Inspect toe-in after the camber has been adjusted.

- (a) Remove the front wheel.
(b) Remove the 2 nuts on the lower side of the shock absorber.

NOTICE:

When removing the nut, stop the bolt from rotating and loosen the nut.

- (c) Clean the installation surfaces of the shock absorber and the steering knuckle.
(d) Temporarily install the 2 nuts.
(e) Fully push or pull the front axle hub in the direction of the required adjustment.
(f) Tighten the nuts.

Torque: 153 N*m (1,560 kgf*cm, 113 ft.*lbf)

NOTICE:

Keep the bolts from rotating and torque the nuts.

- (g) Install the front wheel.
Torque: 103 N*m (1,050 kgf*cm, 76 ft.*lbf)
(h) Check the camber.

If the measured value is not within the specified range, calculate the required adjustment amount using the formula below.

Camber adjustment amount:

Center of the specified range - Measured value

Check the installed bolt combination. Select appropriate bolts from the table below to adjust the camber to within the specified range.

Standard selection table

Item	Selection Table
Move the axle toward (+) in step (e)	Refer to table (1) (Move the axle toward positive side)
Move the axle toward (-) in step (e)	Refer to table (2) (Move the axle toward negative side)

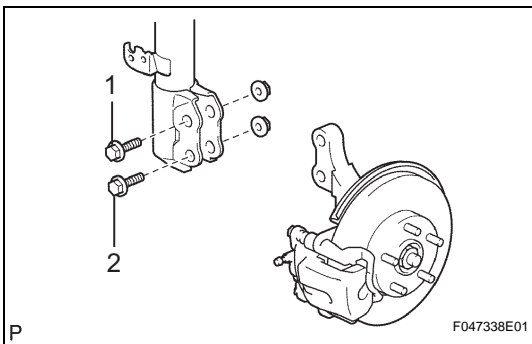
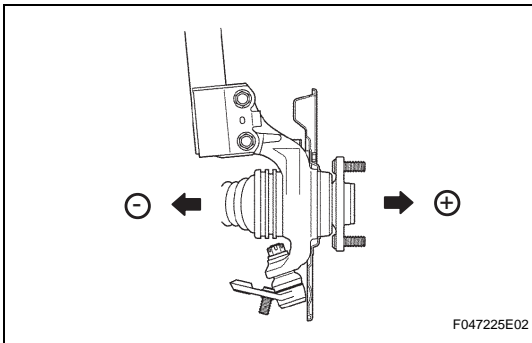















-
- (i) Measure the camber with the bolts currently installed and check the amount of looseness from the specified range. (Ex: The measured value is $-1^{\circ}35'$)
 - (j) Determine whether the direction of the required adjustment is toward the positive or negative side. (Ex: Refer to table (1) (Move the axle toward positive side))
 - (k) Check the required adjustment amount from the measured value. (Table (1), Table (2)) (Ex: Select "Adjust value: $0^{\circ}45'$ to $1^{\circ}00''$ ")
 - (l) Check the currently installed bolt combination. (Ex: "Installed bolt 1: no dot; Installed bolt 2: 2 dots")
 - (m) Select the adjusting bolts. (Ex: "Selected Bolt Combination" results in F for installed bolt 1: 3 dots; Installed bolt 2: 3 dots)
 - (n) Measure the alignment again and check that it is within the specified range. (Ex: Measured value is within $-0^{\circ}35'$ $+45'$)





Table (1) (Move the axle toward positive side)

Installed Bolt Adjusting Value	1	No Dot	No Dot	No Dot	No Dot	1 Dot	2 Dots	3 Dots
	2	No Dot	1 Dot	2 Dots	3 Dots	3 Dots	3 Dots	3 Dots
-1° 30' to -1° 15'								G
-1° 15' to -1° 00'							G	A
-1° 00' to -0° 45'						G	A	B
-0° 45' to -0° 30'					G	A	B	C
-0° 30' to -0° 15'				G	A	B	C	D
-0° 15' to 0°		G	A	B	C	D	E	F
0° to 0° 15'	A	B	C	D	E	F		
0° 15' to 0° 30'	B	C	D	E	F			
0° 30' to 0° 45'	C	D	E	F				
0° 45' to 1° 00'	D	E	F					
1° 00' to 1° 15'	E	F						
1° 15' to 1° 30'	F							

Selected Bolt Combination

	A	B	C	D	E	F	G
1	 90105-15018	 90105-15018	 90105-15018	 90105-15015	 90105-15016	 90105-15017	 90105-15018
2	 90105-15015	 90105-15016	 90105-15017	 90105-15017	 90105-15017	 90105-15017	 90105-15018

Bolt Distinguishing Mark

No Dot	1 Dot	2 Dots	3 Dots
 90105-15018	 90105-15015	 90105-15016	 90105-15017

The body and suspension may be damaged if the camber is not correctly adjusted according to the above table.

NOTICE:

Replace the nut with a new one when replacing the bolt.

(o) Repeat the steps mentioned above. At step (b), replace 1 or 2 selected bolts.















HINT:

Replace 1 bolt at a time when replacing 2 bolts.





Table (2) (Move the axle toward negative side)

Installed Bolt Adjusting Value	1	No Dot	No Dot	No Dot	No Dot	1 Dot	2 Dots	3 Dots
	2	No Dot	1 Dot	2 Dots	3 Dots	3 Dots	3 Dots	3 Dots
-1° 30' to -1° 15'		F	/	/	/	/	/	/
-1° 15' to -1° 00'		E	F	/	/	/	/	/
-1° 00' to -0° 45'		D	E	F	/	/	/	/
-0° 45' to -0° 30'		C	D	E	F	/	/	/
-0° 30' to -0° 15'		B	C	D	E	F	/	/
-0° 15' to 0°		A	B	C	D	E	F	/
0° to 0° 15'	/	/	G	A	B	C	D	E
0° 15' to 0° 30'	/	/	/	G	A	B	C	D
0° 30' to 0° 45'	/	/	/	/	G	A	B	C
0° 45' to 1° 00'	/	/	/	/	/	G	A	B
1° 00' to 1° 15'	/	/	/	/	/	/	G	A
1° 15' to 1° 30'	/	/	/	/	/	/	/	G

Selected Bolt Combination

	A	B	C	D	E	F	G
1	 90105-15018	 90105-15018	 90105-15018	 90105-15015	 90105-15016	 90105-15017	 90105-15018
2	 90105-15015	 90105-15016	 90105-15017	 90105-15017	 90105-15017	 90105-15017	 90105-15018

Bolt Distinguishing Mark

No Dot	1 Dot	2 Dots	3 Dots
 90105-15018	 90105-15015	 90105-15016	 90105-15017

T

C125768E02

The body and suspension may be damaged if the camber is not correctly adjusted according to the above table.

(p) Repeat the steps mentioned above. At step (b), replace 1 or 2 selected bolts.

NOTICE:

Replace the nut with a new one when replacing the bolt.

HINT:

Replace 1 bolt at a time when replacing 2 bolts.

REAR WHEEL ALIGNMENT

INSPECTION

1. **INSPECT TIRE**
 - (a) Inspect the tires (see page [TW-3](#)).
2. **MEASURE VEHICLE HEIGHT**
 - (a) Measure the vehicle height (see page [SP-2](#)).
3. **INSPECT TOE-IN**
Standard toe-in

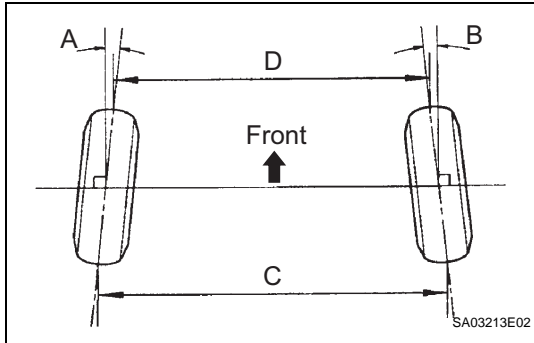

Item	Specified Condition
Toe-in (total)	A + B: 0° 18' +-15' (0.30° +-0.25°) C - D: 3.0 +-2.5 mm (0.12 +-0.10 in.)

HINT:

- Measure "C - D" only when "A + B" cannot be measured.
- If the toe-in is not within the specified range, inspect the suspension parts for damage and/or wear, and replace them if necessary.

4. **INSPECT CAMBER**
 - (a) Install the camber-caster-kingpin gauge or set the vehicle on a wheel alignment tester.
 - (b) Inspect the camber.
Standard camber

Item	Specified Condition
Camber Right-left error	-1° 30' +-30' (-1.50 +-0.5°) 30' (0.5°) or less

HINT:

Camber is not adjustable. If the measurement is not within the specified range, inspect the suspension parts for damage and/or wear, and replace them if necessary.

FRONT SHOCK ABSORBER WITH COIL SPRING

COMPONENTS

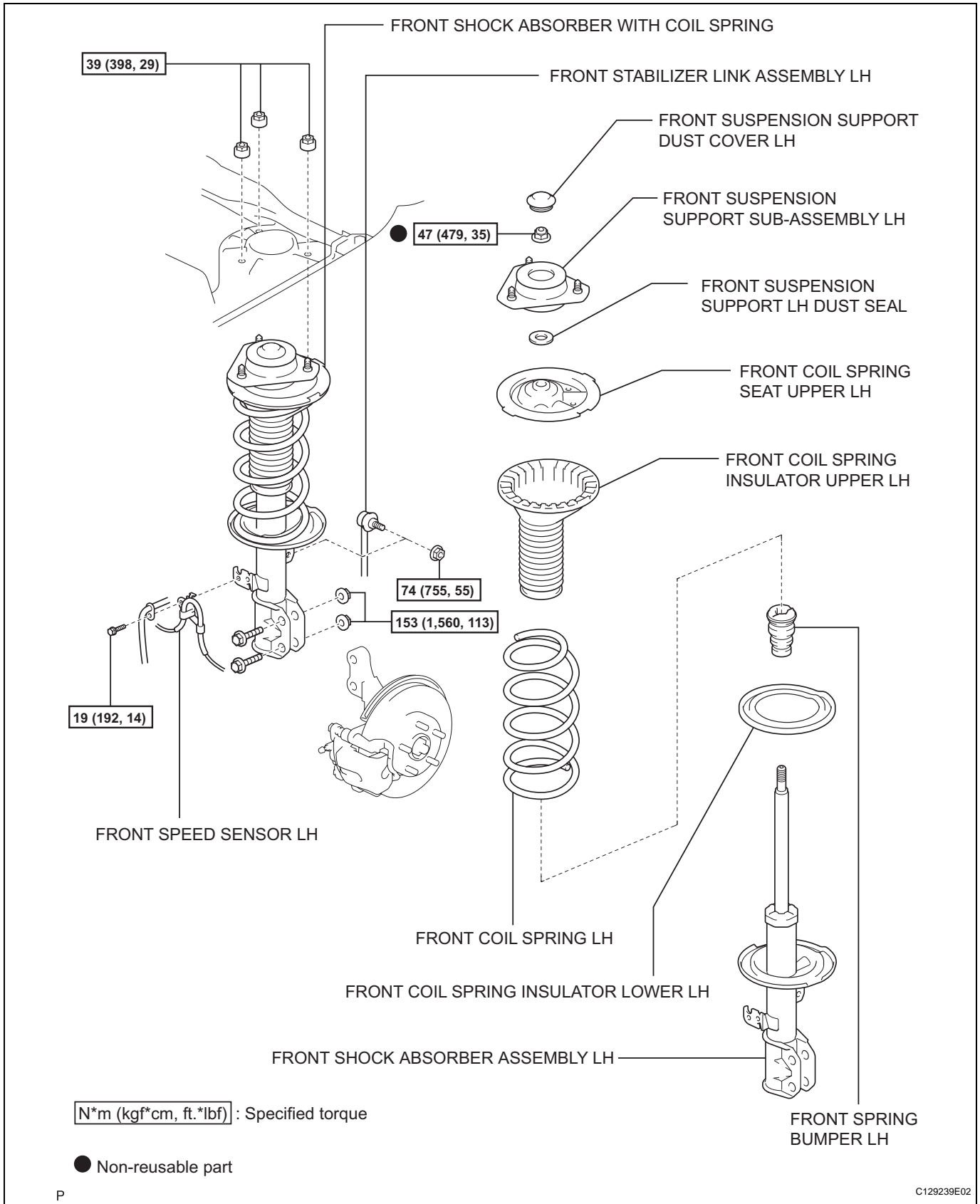

SP

REMOVAL

HINT:

- Use the same procedures for the RH side and LH side.
- The procedures listed below are for the LH side.

1. REMOVE FRONT WHEEL
2. REMOVE FRONT WIPER ARM HEAD CAP
3. REMOVE FRONT WIPER ARM LH (See page [WW-13](#))
4. REMOVE FRONT WIPER ARM RH (See page [WW-13](#))
5. REMOVE HOOD TO COWL TOP SEAL (See page [WW-13](#))
6. REMOVE COWL TOP VENTILATOR LOUVER LH (See page [WW-13](#))
7. REMOVE COWL TOP VENTILATOR LOUVER RH (See page [WW-13](#))
8. REMOVE WINDSHIELD WIPER MOTOR AND LINK (See page [WW-13](#))
9. DISCONNECT FRONT STABILIZER LINK ASSEMBLY

- (a) Place a wooden block on a jack, and support the front suspension lower No. 1 arm with the jack.
- (b) Remove the nut and separate the front stabilizer link from the shock absorber with coil spring.

HINT:

Use a 6 mm hexagon wrench to hold the stud if the ball joint turns together with the nut.

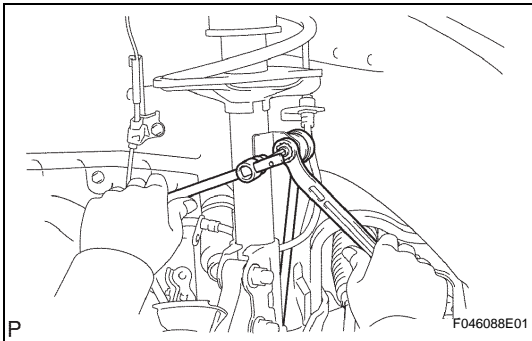

10. REMOVE FRONT SHOCK ABSORBER WITH COIL SPRING

- (a) Remove the bolt and disconnect the front flexible hose No. 1 and speed sensor front LH wire harness.

NOTICE:

Be sure to completely disconnect the speed sensor front LH from the front shock absorber.

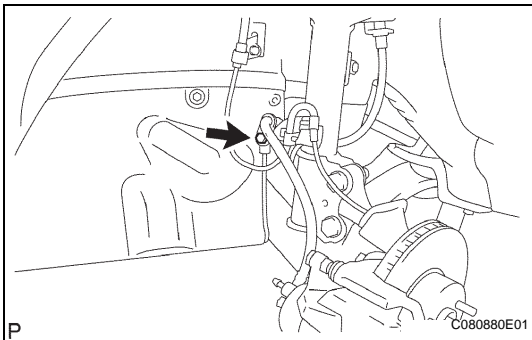

- (b) Remove the 2 nuts on the lower side of the front shock absorber with coil spring.

NOTICE:

Keep the bolts inserted.

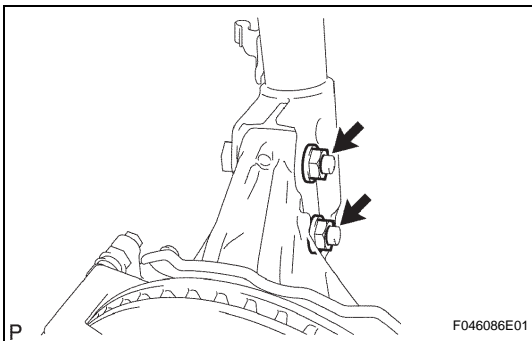

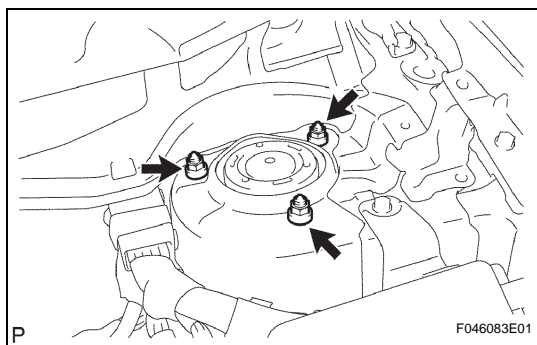

- (c) Remove the 3 nuts.
- (d) Lower the jack slowly. Remove the 2 bolts on the lower side and the front shock absorber with coil spring.

NOTICE:

Ensure that the speed sensor front LH is completely disconnected from the front shock absorber with coil spring.

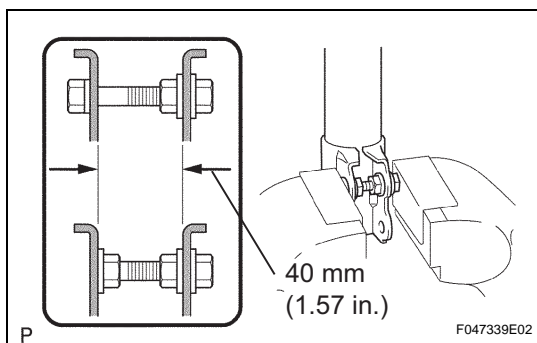
**DISASSEMBLY****1. FIX FRONT SHOCK ABSORBER WITH COIL SPRING**

- (a) Secure the front shock absorber with coil spring in a vise by clamping onto a double nutted bolt affixed to the bracket at the bottom of the absorber, as shown in the illustration to the left.

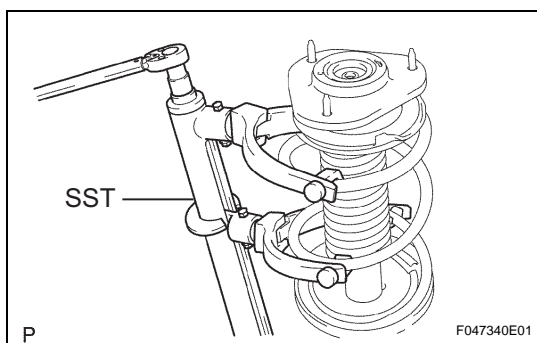
**2. REMOVE FRONT SUPPORT TO FRONT SHOCK ABSORBER LH NUT**

- (a) Attach SST to the coil spring so that the upper and lower hooks of the installed area are as wide as possible.
SST 09727-30021 (09727-00010, 09727-00021, 09727-00031)
- (b) Fully compress the coil spring.

NOTICE:

Do not use an impact wrench. It will damage SST.

HINT:

The coil spring can also be installed/removed using the hydraulic spring compressor.

- (c) Remove the front suspension support dust cover.
- (d) Secure the front coil spring seat upper with SST and remove the front suspension support to front shock absorber LH nut.
SST 09729-22031

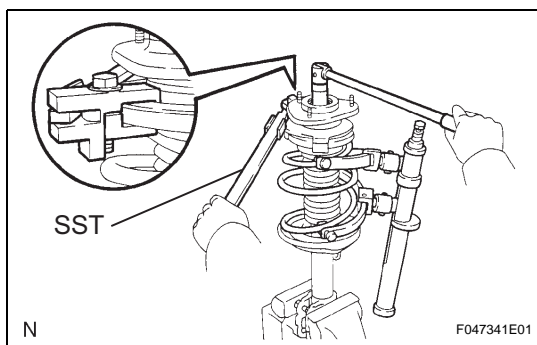
**3. REMOVE FRONT SUSPENSION SUPPORT SUB-ASSEMBLY LH****4. REMOVE FRONT SUSPENSION SUPPORT LH DUST SEAL****5. REMOVE FRONT COIL SPRING SEAT UPPER LH****6. REMOVE FRONT COIL SPRING INSULATOR UPPER LH****7. REMOVE FRONT COIL SPRING LH****8. REMOVE FRONT SPRING BUMPER LH**

9. REMOVE FRONT COIL SPRING INSULATOR LOWER LH

10. REMOVE FRONT SHOCK ABSORBER ASSEMBLY LH

INSPECTION

1. INSPECT FRONT SHOCK ABSORBER ASSEMBLY LH

- (a) Compress and extend the shock absorber rod 4 or more times. Check that there is no abnormal resistance or sound.

If there is any abnormality, replace the shock absorber front LH with a new one.

NOTICE:

When disposing of the shock absorber, see DISPOSAL (see page [SP-17](#)).

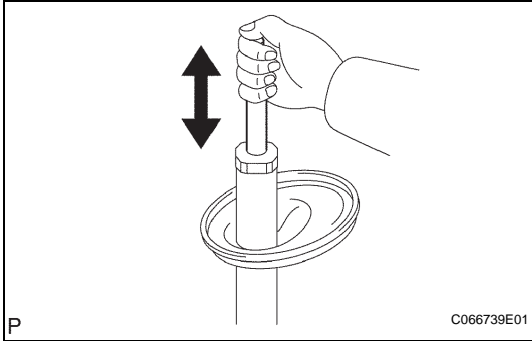

REASSEMBLY

1. **INSTALL FRONT SHOCK ABSORBER ASSEMBLY LH**
2. **INSTALL FRONT COIL SPRING INSULATOR LOWER LH**

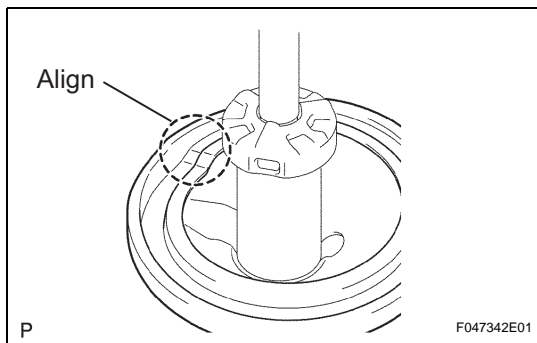

- (a) Install the front coil spring insulator lower to the front shock absorber so that both recessed parts are aligned.

3. **INSTALL FRONT SPRING BUMPER LH**

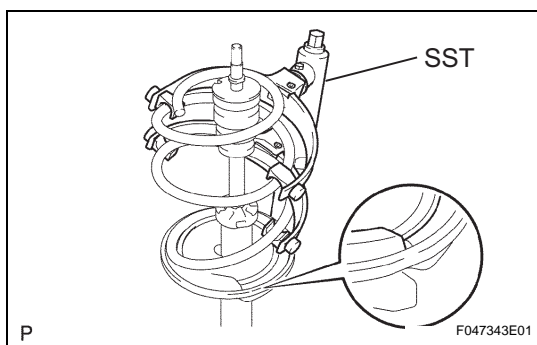

4. **INSTALL FRONT COIL SPRING LH**

- (a) Using SST, compress the coil spring.
SST 09727-30021 (09727-00010, 09727-00021, 09727-00031)

NOTICE:

Do not use an impact wrench. It will damage SST.

HINT:

The coil spring can also be installed/removed using the hydraulic spring compressor.

- (b) Fit the lower end of the front coil spring LH into the recessed part of the spring lower seat.

HINT:

Install the spring with the smaller diameter on top.

5. **INSTALL FRONT COIL SPRING INSULATOR UPPER LH**

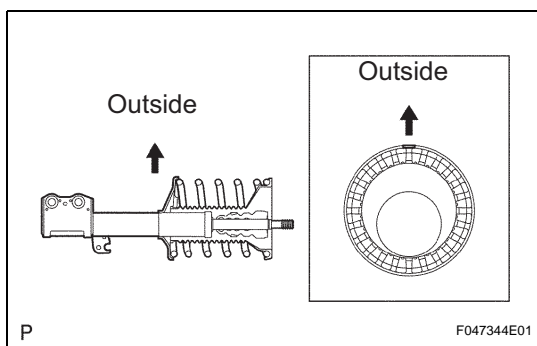

- (a) Install the front coil spring insulator upper to the front shock absorber with the protruding part facing the outside of the vehicle.

6. **INSTALL FRONT COIL SPRING SEAT UPPER LH**

- (a) Install the front coil spring seat upper with the recess facing the outside of the vehicle.

NOTICE:

- Fit the protruding part of the front coil spring insulator upper LH to the recess of the front coil spring seat upper LH.
- Ensure that the width across the flat parts of the piston rod and the front coil spring seat upper LH are fitted.

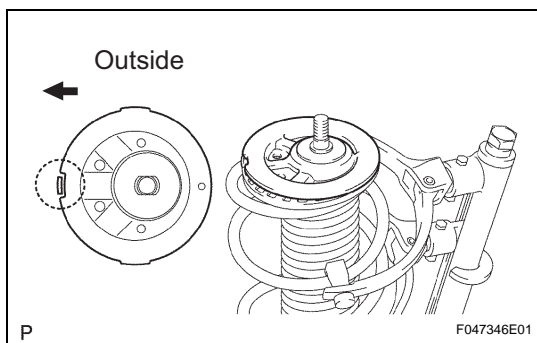

7. **INSTALL FRONT SUSPENSION SUPPORT LH DUST SEAL**

8. **INSTALL FRONT SUSPENSION SUPPORT SUB-ASSEMBLY LH**

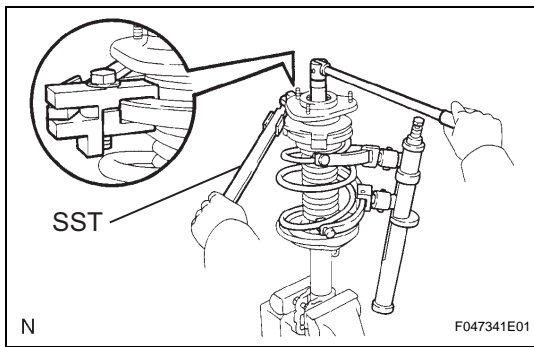

9. INSTALL FRONT SUPPORT TO FRONT SHOCK ABSORBER LH NUT

- (a) Secure the front coil spring seat upper with SST and tighten it with a new nut.

Torque: 47 N*m (479 kgf*cm, 35 ft.*lbf)

- (b) Release SST while aligning the protruding part of the front coil spring insulator upper, the recess of the spring front coil spring seat upper and the shock absorber lower bracket, and then remove SST from the coil spring.

SST 09729-22031

NOTICE:

Do not use an impact wrench when removing SST.

- (c) Apply No. 2 MP grease to the parts indicated in the illustration and install the front suspension support dust cover.

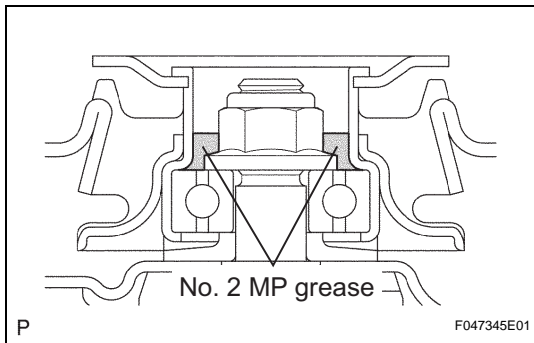

INSTALLATION

HINT:

- Use the same procedures for the RH side and LH side.
- The procedures listed below are for the LH side.

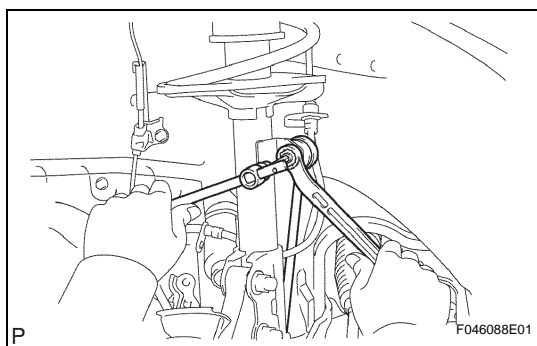
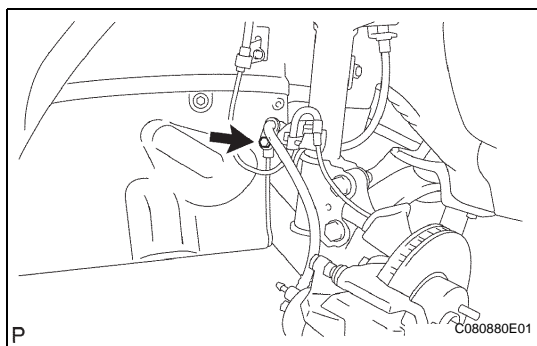
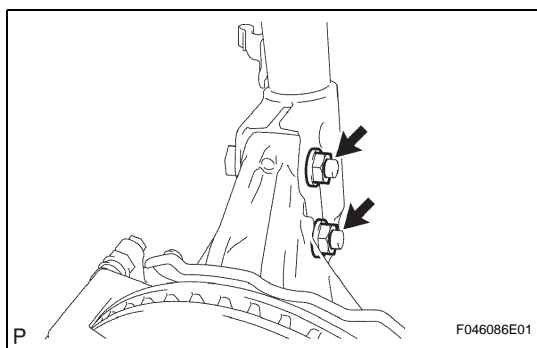
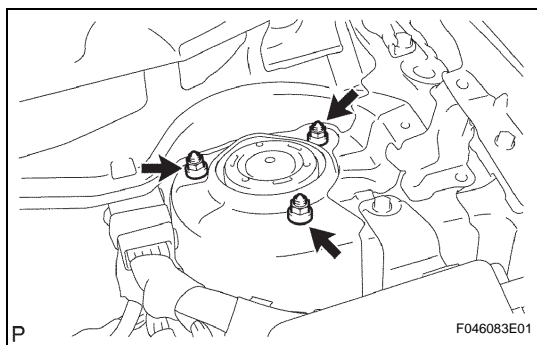

1. INSTALL FRONT SHOCK ABSORBER WITH COIL SPRING

- Insert the 2 bolts from the front side of the vehicle and install the front shock absorber with coil spring to the steering knuckle.
- Place a wooden block between the front shock absorber with coil spring and a jack. Slowly raise the jack and install the front shock absorber with coil spring (upper side) to the vehicle.
- Install the front shock absorber with coil spring (upper side) with the 3 nuts.
Torque: 39 N*m (398 kgf*cm, 29 ft.*lbf)
- Install the front shock absorber with coil spring to the steering knuckle with the 2 nuts.
Torque: 153 N*m (1,560 kgf*cm, 113 ft.*lbf)

- Connect the front flexible hose No. 1 and the speed sensor front LH to the shock absorber with the bolt.
Torque: 19 N*m (192 kgf*cm, 14 ft.*lbf)

NOTICE:

Do not twist the speed sensor front while installing.

2. CONNECT FRONT STABILIZER LINK ASSEMBLY LH

- Connect the front stabilizer link to the front shock absorber with coil spring with the nut.
Torque: 74 N*m (755 kgf*cm, 55 ft.*lbf)

HINT:

Use a 6 mm hexagon wrench to hold the stud if the ball joint turns together with the nut.

3. INSTALL WINDSHIELD WIPER MOTOR AND LINK (See page [WW-16](#))

4. INSTALL COWL TOP VENTILATOR LOUVER LH (See page [WW-17](#))

5. INSTALL COWL TOP VENTILATOR LOUVER RH (See page [WW-17](#))

6. **INSTALL HOOD TO COWL TOP SEAL** (See page [WW-17](#))
7. **INSTALL FRONT WIPER ARM LH** (See page [WW-16](#))
8. **INSTALL FRONT WIPER ARM RH** (See page [WW-16](#))
9. **INSTALL FRONT WIPER ARM HEAD CAP**
10. **INSTALL FRONT WHEEL**
Torque: 103 N*m (1,050 kgf*cm, 76 ft.*lbf)
11. **INSPECT AND ADJUST FRONT WHEEL ALIGNMENT**
 - (a) Inspect and adjust the front wheel alignment (see page [SP-2](#)).

DISPOSAL

HINT:

Dispose of the RH side following the same procedures as the LH side.

1. DISPOSE OF FRONT SHOCK ABSORBER ASSEMBLY LH

- (a) Fully extend the shock absorber rod.
- (b) Using a drill, make a hole in the cylinder between A and B shown in the illustration to discharge the gas inside.

CAUTION:

Be careful when drilling because shards of metal may fly about, so always use the proper safety equipment.

NOTICE:

The gas is colorless, odorless and non-poisonous.

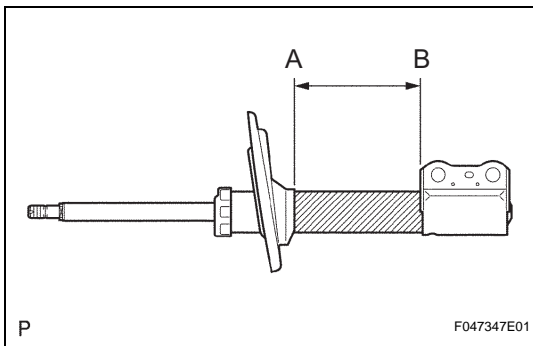

FRONT SUSPENSION LOWER NO. 1 ARM

COMPONENTS

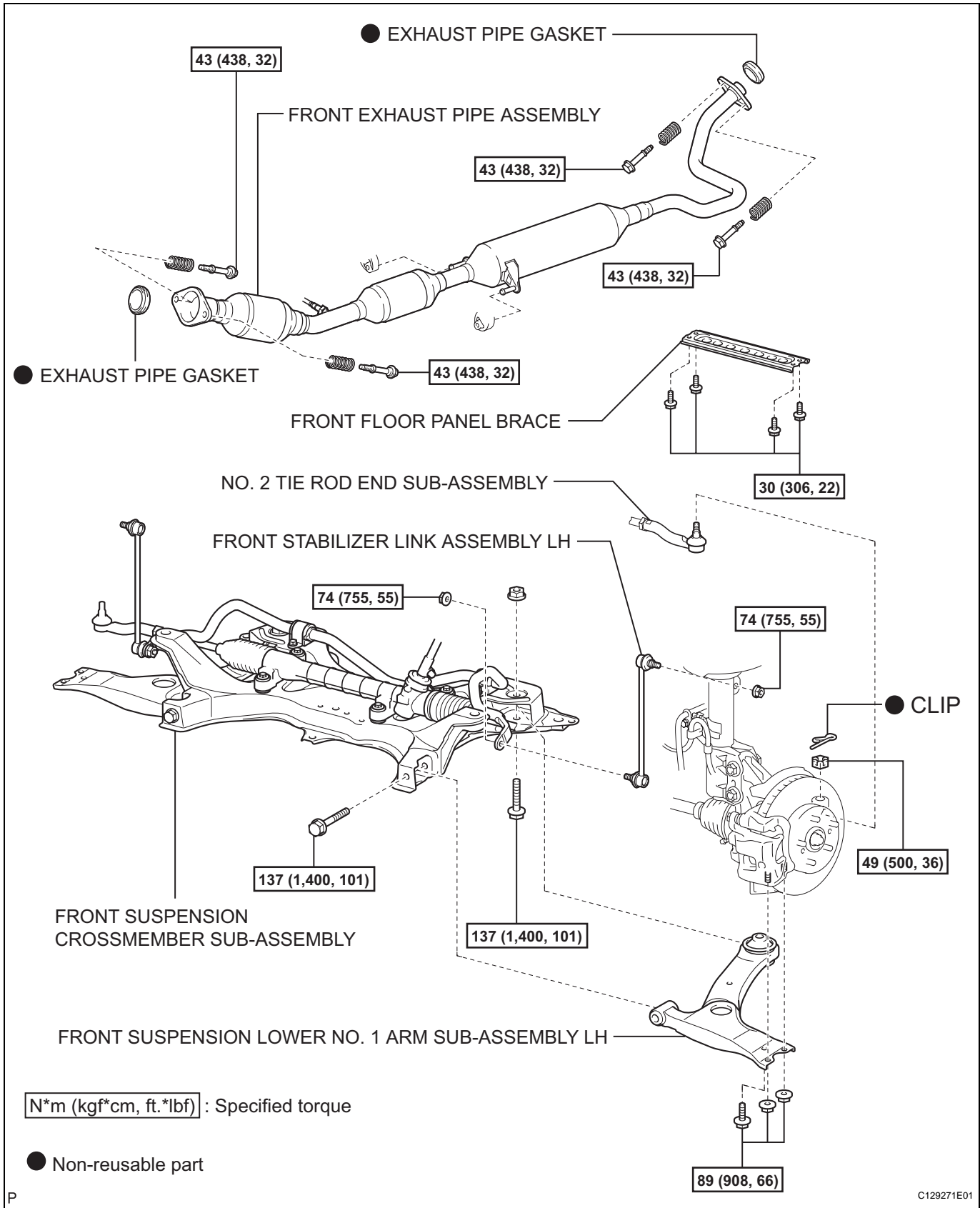

REMOVAL

HINT:

- Use the same procedures for the RH side and LH side.
- The procedures listed below are for the LH side.

1. PLACE FRONT WHEELS FACING STRAIGHT AHEAD
2. REMOVE COLUMN HOLE COVER SILENCER SHEET (See page [SR-10](#))
3. DISCONNECT STEERING SLIDING YOKE SUB-ASSEMBLY (See page [PS-50](#))
4. REMOVE FRONT WHEEL
5. REMOVE FRONT EXHAUST PIPE ASSEMBLY (See page [EX-2](#))
6. REMOVE FRONT AXLE HUB NUT LH (See page [DS-5](#))

7. REMOVE FRONT AXLE HUB NUT RH

HINT:

Use the same procedures described for the LH side.

8. DISCONNECT NO. 2 TIE ROD END SUB-ASSEMBLY (See page [DS-6](#))
9. DISCONNECT NO. 1 TIE ROD END SUB-ASSEMBLY (See page [PS-50](#))
10. DISCONNECT FRONT SUSPENSION LOWER NO. 1 ARM SUB-ASSEMBLY LH
 - (a) Remove the bolt and 2 nuts.
 - (b) Lower the front suspension lower No. 1 arm and disconnect it from the front lower ball joint.

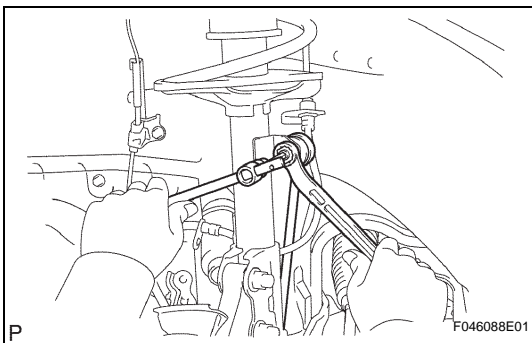
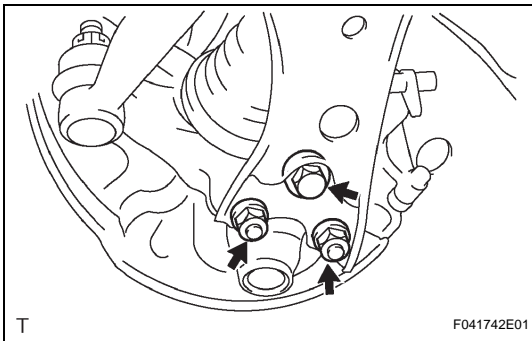

11. REMOVE FRONT STABILIZER LINK ASSEMBLY

- (a) Remove the nuts and disconnect the stabilizer link LH and RH from the front shock absorber with coil spring.

HINT:

Use a 6 mm hexagon wrench to hold the stud if the ball joint turns together with the nut.

12. DISCONNECT FRONT SUSPENSION LOWER NO. 1 ARM SUB-ASSEMBLY RH

HINT:

Remove the RH side following the same procedures as the LH side.

13. REMOVE FRONT AXLE ASSEMBLY LH (See page [AH-6](#))

14. REMOVE FRONT AXLE ASSEMBLY RH

HINT:

Remove the RH side following the same procedures as the LH side.

15. REMOVE FRONT DRIVE SHAFT ASSEMBLY LH (See page DS-7)**16. REMOVE FRONT DRIVE SHAFT ASSEMBLY RH (See page DS-7)****17. DISCONNECT FRONT SUSPENSION CROSSMEMBER SUB-ASSEMBLY****18. REMOVE FRONT SUSPENSION LOWER NO. 1 ARM SUB-ASSEMBLY LH**

- (a) Remove the 2 bolts, nut and front suspension lower No. 1 arm.

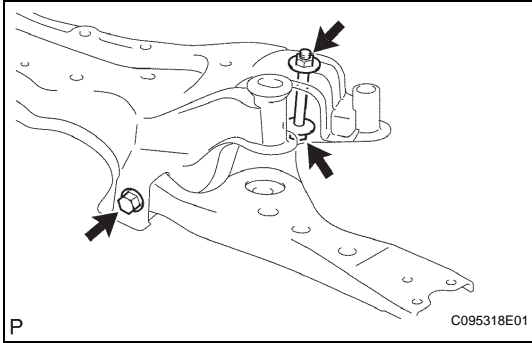
NOTICE:**Keep the nut from rotating and loosen the bolt.**

INSTALLATION

HINT:

- Use the same procedures for the RH side and LH side.
- The procedures listed below are for the LH side.

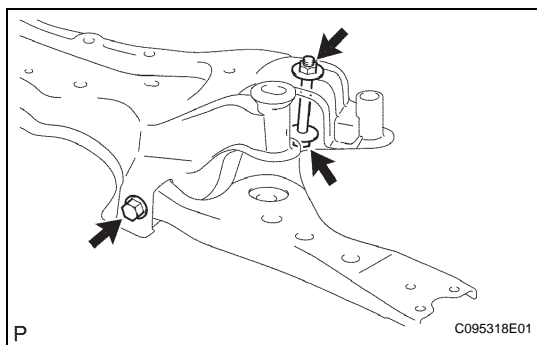

1. TEMPORARILY TIGHTEN FRONT SUSPENSION LOWER NO. 1 ARM SUB-ASSEMBLY LH

- (a) Install the front suspension lower No. 1 arm to the suspension crossmember and temporarily tighten the front suspension lower No. 1 arm with the 2 bolts and nut.

2. CONNECT FRONT SUSPENSION CROSSMEMBER SUB-ASSEMBLY

3. INSTALL FRONT DRIVE SHAFT ASSEMBLY LH (See page DS-15)

4. INSTALL FRONT DRIVE SHAFT ASSEMBLY RH (See page DS-15)

5. INSTALL FRONT AXLE ASSEMBLY LH (See page AH-6)

6. INSTALL FRONT AXLE ASSEMBLY RH

HINT:

Install the RH side following the same procedures as the LH side.

7. INSTALL FRONT SUSPENSION LOWER NO. 1 ARM SUB-ASSEMBLY LH

- (a) Install the front suspension lower No. 1 arm to the front lower ball joint with the bolt and 2 nuts.
Torque: 89 N*m (908 kgf*cm, 66 ft.*lbf)

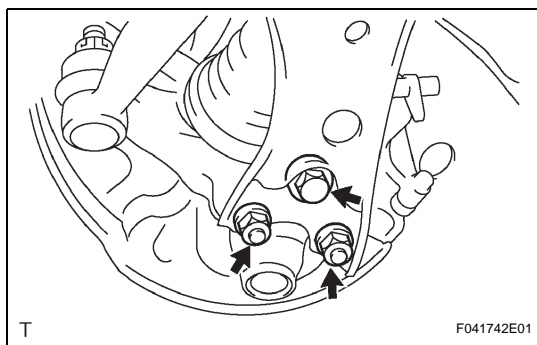

8. INSTALL FRONT SUSPENSION LOWER NO. 1 ARM SUB-ASSEMBLY RH

HINT:

Install the RH side following the same procedures as the LH side.

9. INSTALL FRONT STABILIZER LINK ASSEMBLY

- (a) Connect the front stabilizer link LH and RH to the front shock absorber with coil spring with the nuts.
Torque: 74 N*m (755 kgf*cm, 55 ft.*lbf)

HINT:

Use a 6 mm hexagon wrench to hold the stud if the ball joint turns together with the nut.

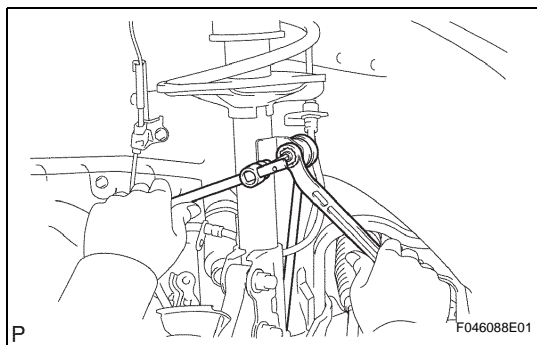

10. INSTALL NO. 2 TIE ROD END SUB-ASSEMBLY (See page PS-55)

11. INSTALL NO. 1 TIE ROD END SUB-ASSEMBLY (See page PS-50)

12. INSTALL FRONT AXLE HUB NUT LH (See page AH-7)

13. INSTALL FRONT AXLE HUB NUT RH

HINT:

Install the RH side following the same procedures as the LH side.

14. INSTALL FRONT WHEEL

Torque: 103 N*m (1,050 kgf*cm, 76 ft.*lbf)

15. INSTALL FRONT EXHAUST PIPE ASSEMBLY (See page EX-3)**16. STABILIZE SUSPENSION**

- (a) Lower the vehicle and bounce it up and down several times to stabilize the front suspension.

17. CONNECT STEERING SLIDING YOKE SUB-ASSEMBLY (See page PS-56)**18. INSTALL COLUMN HOLE COVER SILENCER SHEET****19. FULLY TIGHTEN FRONT SUSPENSION LOWER NO. 1 ARM SUB-ASSEMBLY LH**

- (a) Fully tighten the 2 bolts.

Torque: 137 N*m (1,400 kgf*cm, 101 ft.*lbf)

NOTICE:

- Keep the nut from rotating while tightening the rear-side bolt.
- Lower the tires to the ground using a 4-post lift.

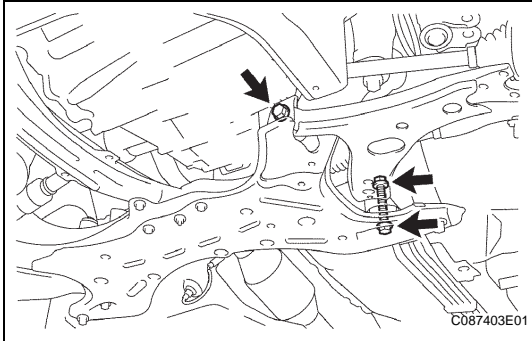
**20. INSPECT AND ADJUST FRONT WHEEL ALIGNMENT**

- (a) Inspect and adjust the front wheel alignment (see page SP-2).

FRONT LOWER BALL JOINT

COMPONENTS

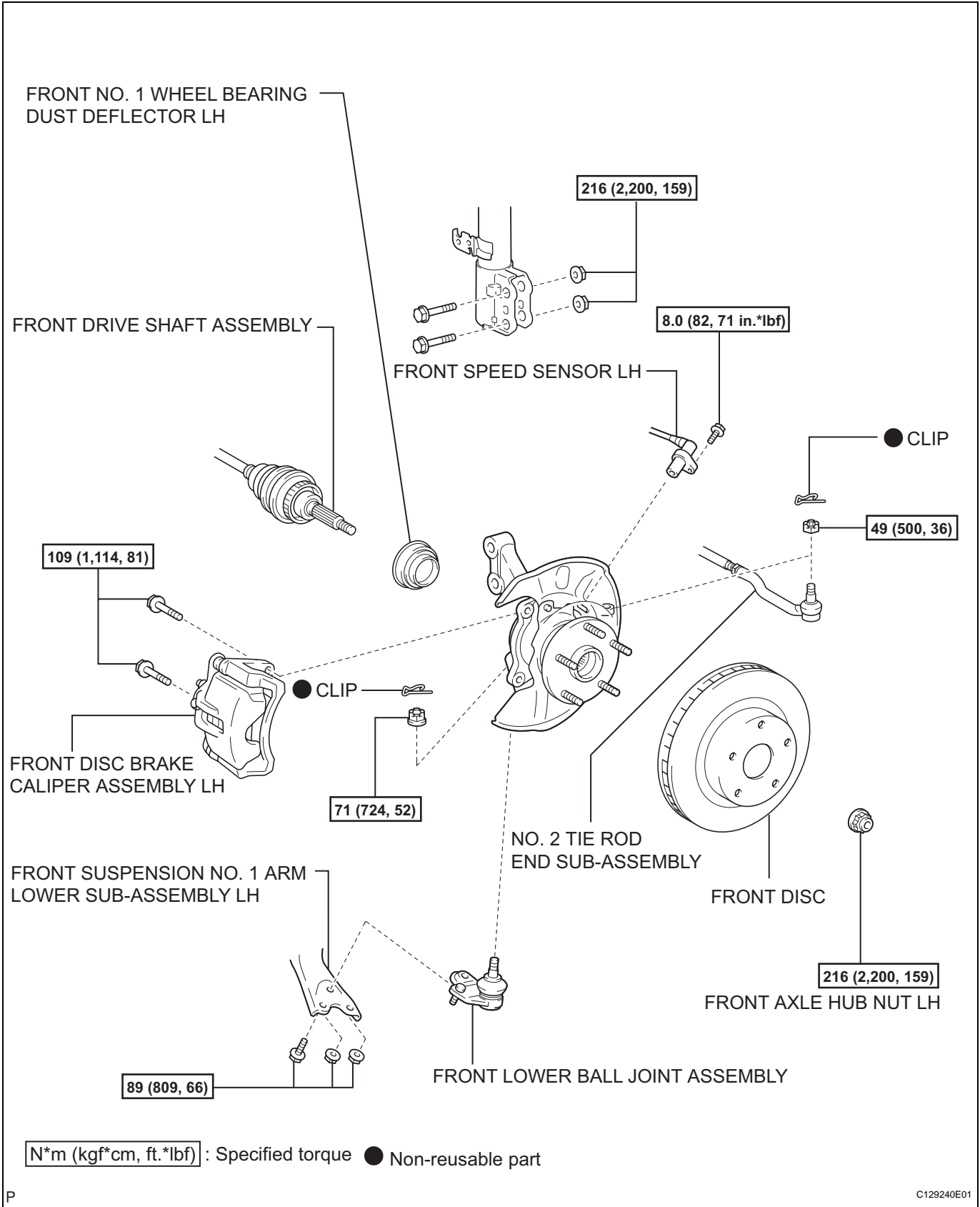

SP

REMOVAL

HINT:

- Use the same procedures for the RH side and LH side.
- The procedures listed below are for the LH side.

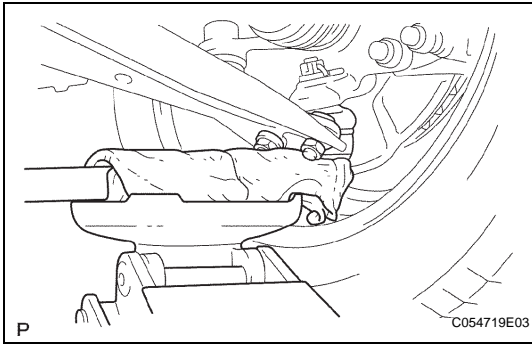

1. INSPECT FRONT LOWER BALL JOINT ASSEMBLY LH

- Jack up the front part of the vehicle.
- Move the front suspension lower No. 1 arm up and down to check vertical looseness of the lower ball joint front.

HINT:

Wrap a cloth around the wooden block to prevent damage to the bolt and nuts.

2. REMOVE FRONT WHEEL

3. REMOVE FRONT AXLE HUB NUT LH (See page DS-5)

4. DISCONNECT FRONT SPEED SENSOR LH (See page BC-218)

5. DISCONNECT FRONT DISC BRAKE CALIPER ASSEMBLY LH (See page BR-40)

6. REMOVE FRONT DISC (See page BR-42)

7. DISCONNECT NO. 2 TIE ROD END SUB-ASSEMBLY (See page DS-6)

8. DISCONNECT FRONT SUSPENSION LOWER NO. 1 ARM SUB-ASSEMBLY LH

- Remove the bolt and 2 nuts.
- Lower the front suspension lower No. 1 arm and disconnect it from the front lower ball joint.

9. REMOVE FRONT AXLE ASSEMBLY LH (See page AH-6)

10. REMOVE FRONT NO. 1 WHEEL BEARING DUST DEFLECTOR LH (See page AH-5)

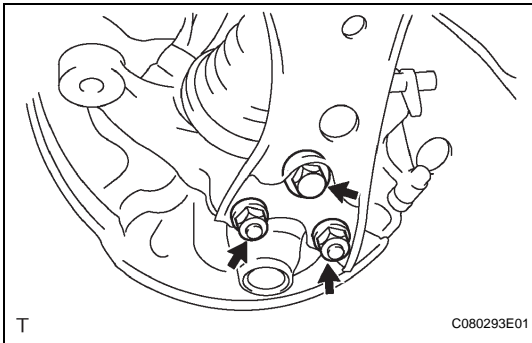

11. REMOVE FRONT LOWER BALL JOINT ASSEMBLY LH

- Remove the clip and the castle nuts.
- Using SST, remove the lower ball joint front.

SST 09611-36020

NOTICE:

- Do not damage the steering knuckle.
- Securely hang SST to the spacer of the steering knuckle.
- Replace the steering knuckle with a new one if the spacer comes off the steering knuckle.

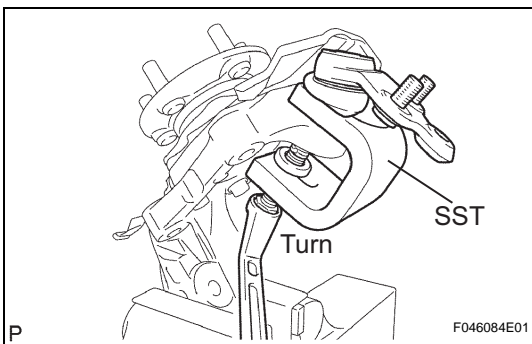

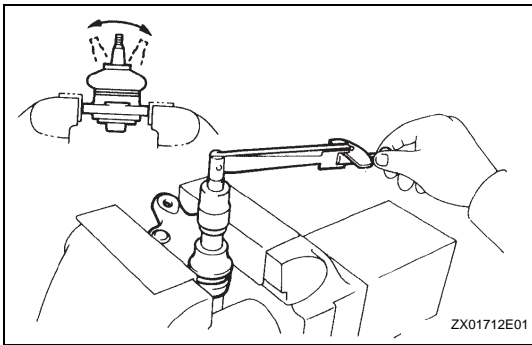

INSPECTION

1. INSPECT FRONT LOWER BALL JOINT ASSEMBLY LH

- (a) Flip the ball joint stud back and forth 5 times as shown in the illustration before installing the nut.
- (b) Use a torque wrench to turn the nut continuously at a rate of 3 to 5 seconds per turn. Take the torque reading on the fifth turn.
Torque: 0.98 to 4.90 N*m (10 to 50 kgf*cm, 8.7 to 43 in.*lbf)
- (c) Check the dust boots for cracks or grease leakage. If the value is not within the specified range, replace the lower ball joint with a new one.

INSTALLATION

HINT:

- Use the same procedures for the RH side and LH side.
- The procedures listed below are for the LH side.

1. INSTALL FRONT LOWER BALL JOINT ASSEMBLY

- (a) Install the lower ball joint front LH to the steering knuckle with the castle nuts.

NOTICE:

Ensure that the thread and taper are free of oil, etc.

Torque: 71 N*m (724 kgf*cm, 52 ft.*lbf)

NOTICE:

Further tighten the nut up to 60° if the holes for the cotter pin are not aligned.

- (b) Install a new clip to the steering knuckle.

2. INSTALL FRONT NO. 1 WHEEL BEARING DUST DEFLECTOR LH (See page [AH-6](#))

3. INSTALL FRONT AXLE ASSEMBLY LH (See page [AH-6](#))

4. CONNECT FRONT SUSPENSION LOWER NO. 1 ARM SUB-ASSEMBLY LH

- (a) Lower the front suspension lower No. 1 arm and install the lower ball joint front to the front suspension lower No. 1 arm with the bolt and 2 nuts.

Torque: 89 N*m (908 kgf*cm, 66 ft.*lbf)

5. CONNECT NO. 2 TIE ROD END SUB-ASSEMBLY (See page [PS-55](#))

6. INSTALL FRONT DISC (See page [BR-43](#))

7. CONNECT FRONT DISC BRAKE CALIPER ASSEMBLY LH (See page [BR-45](#))

8. INSTALL FRONT SPEED SENSOR LH (See page [BC-218](#))

9. INSTALL FRONT AXLE HUB NUT LH (See page [AH-7](#))

10. INSTALL FRONT WHEEL

Torque: 103 N*m (1,050 kgf*cm, 76 ft.*lbf)

11. INSPECT AND ADJUST FRONT WHEEL ALIGNMENT

- (a) Inspect and adjust the front wheel alignment (see page [SP-2](#)).

12. CHECK SPEED SENSOR SIGNAL

- (a) Check the speed sensor signal (see page [BC-37](#)).

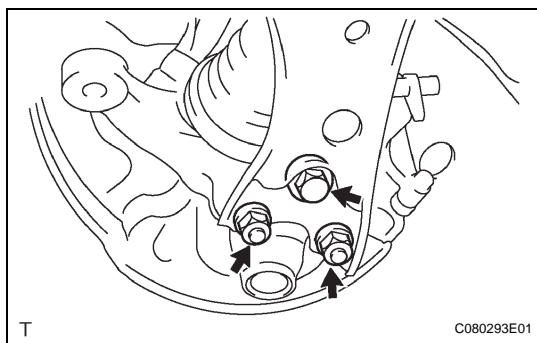

FRONT STABILIZER BAR

COMPONENTS

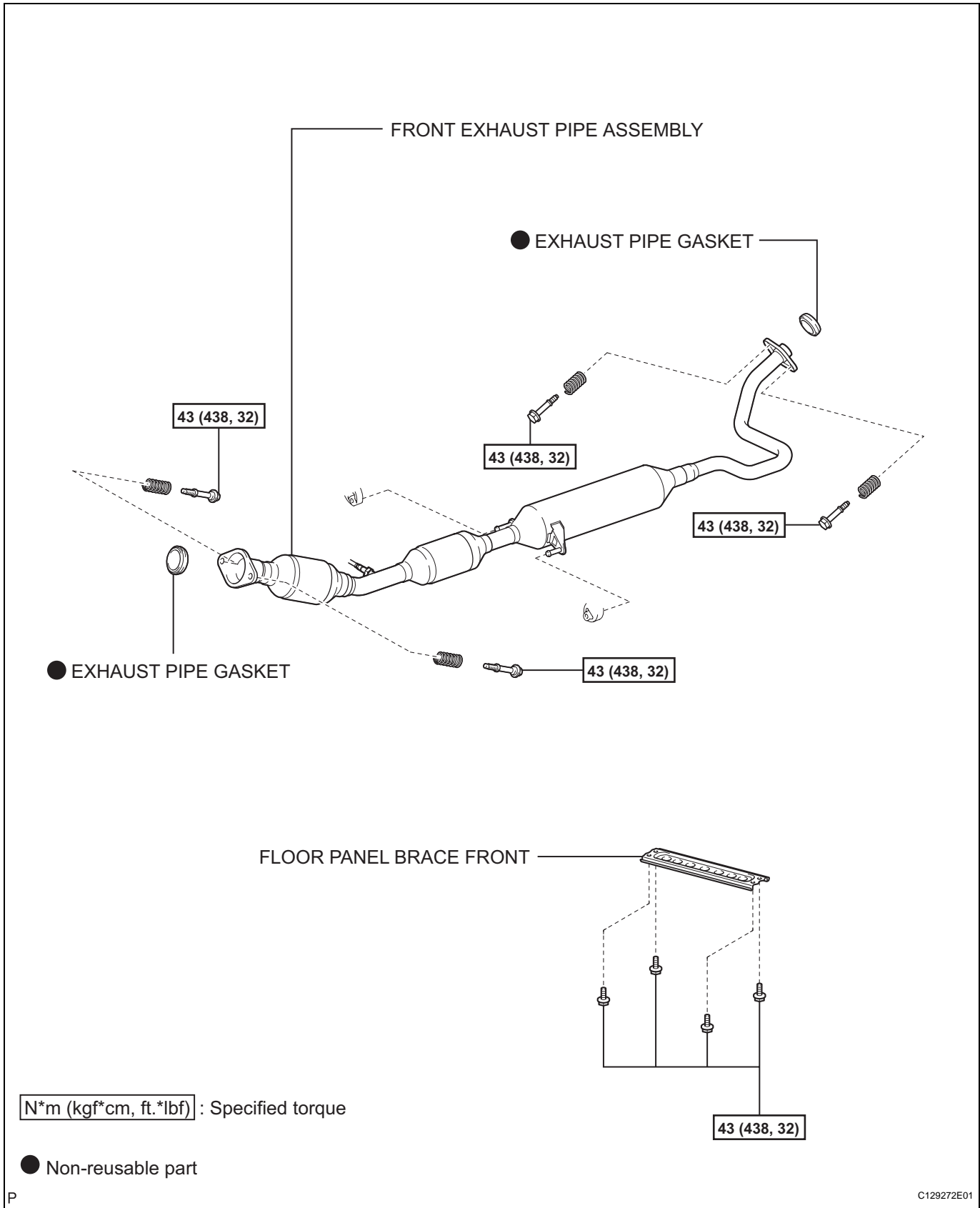

SP

$N \cdot m$ (kgf \cdot cm, ft. \cdot lbf) : Specified torque

● Non-reusable part

P

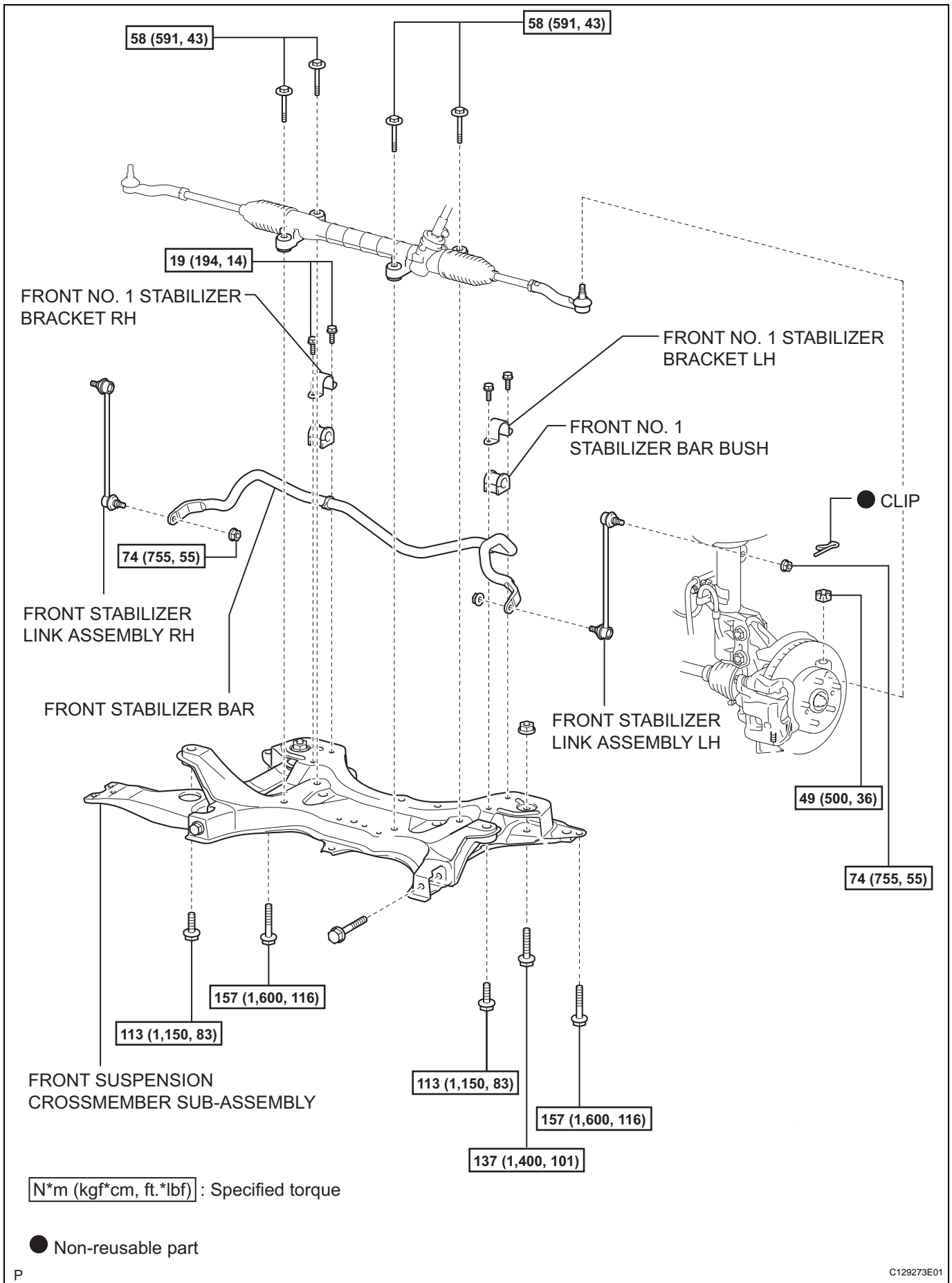

SP

REMOVAL

1. PLACE FRONT WHEELS FACING STRAIGHT AHEAD
2. REMOVE COLUMN HOLE COVER SILENCER SHEET (See page [SR-10](#))
3. DISCONNECT STEERING SLIDING YOKE SUB-ASSEMBLY (See page [PS-50](#))
4. DISCONNECT NO. 1 STEERING COLUMN HOLE COVER SUB-ASSEMBLY (See page [PS-50](#))
5. REMOVE FRONT WHEEL
6. REMOVE FRONT STABILIZER LINK ASSEMBLY LH
 - (a) Remove the 2 nuts and front stabilizer link LH.
 - HINT:
Use a 6 mm hexagon wrench to hold the stud if the ball joint turns together with the nut.
7. DISCONNECT NO. 2 TIE ROD END SUB-ASSEMBLY (See page [DS-6](#))
8. DISCONNECT NO. 1 TIE ROD END SUB-ASSEMBLY (See page [PS-50](#))
9. REMOVE FLOOR PANEL BRACE FRONT (See page [EX-2](#))
10. REMOVE FRONT EXHAUST PIPE ASSEMBLY (See page [EX-2](#))
11. DISCONNECT FRONT NO. 1 STABILIZER BRACKET LH
 - (a) Remove the 2 bolts and the No. 1 stabilizer bracket from the front suspension crossmember.
12. DISCONNECT FRONT NO. 1 STABILIZER BRACKET RH
 - HINT:
Remove the RH side following the same procedures as the LH side.
13. REMOVE STEERING INTERMEDIATE SHAFT (See page [PS-51](#))
14. REMOVE NO. 1 STEERING COLUMN HOLE COVER SUB-ASSEMBLY
15. REMOVE STEERING GEAR ASSEMBLY (See page [PS-51](#))
16. REMOVE FRONT NO. 1 STABILIZER BAR BUSH
 - (a) Remove the 2 front No. 1 stabilizer bar bushes from the stabilizer bar.
17. REMOVE FRONT STABILIZER BAR
 - (a) Remove the front stabilizer bar from the right side of the vehicle.

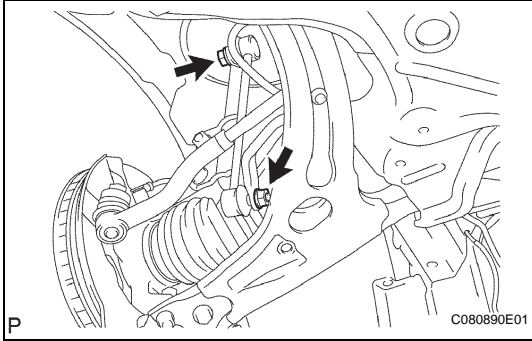

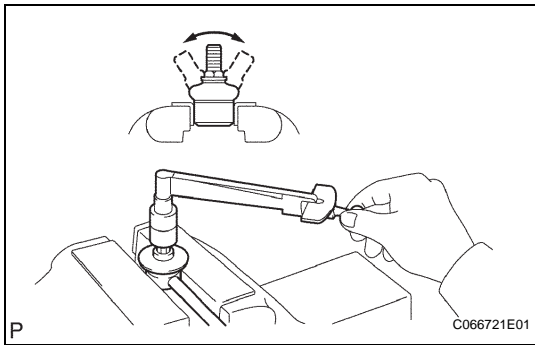

INSPECTION

1. INSPECT FRONT STABILIZER LINK ASSEMBLY

- (a) Flip the ball joint stud back and forth 5 times as shown in the illustration before installing the nut.
- (b) Use a torque wrench to turn the nut continuously at a rate of 2 to 4 seconds per turn. Take the torque reading on the fifth turn.

Torque: 0.05 to 1.96 N*m (0.5 to 20 kgf*cm, 0.4 to 17.4 in.*lbf)

- (c) Check the dust cover for cracks or grease leakage. If the value is not within the specified range, replace the front stabilizer link with a new one.

INSTALLATION

1. INSTALL FRONT STABILIZER BAR

- (a) Insert the front stabilizer bar from the right side of the vehicle.

2. INSTALL FRONT NO. 1 STABILIZER BAR BUSH

- (a) Install the bush to the outer side of the bush stopper on the stabilizer bar.

NOTICE:

- Place the cutout of the stabilizer bush facing the rear side.
- Ensure the right and left deviation of the stabilizer bar is 5 mm (0.20 in.) or less.

3. INSTALL STEERING GEAR ASSEMBLY (See page PS-54)

4. INSTALL NO. 1 STEERING COLUMN HOLE COVER SUB-ASSEMBLY (See page PS-55)

5. INSTALL STEERING INTERMEDIATE SHAFT (See page PS-55)

6. CONNECT FRONT NO. 1 STABILIZER BRACKET LH

- (a) Install the No. 1 stabilizer bracket the front suspension crossmember with the 2 bolts.

Torque: 19 N*m (194 kgf*cm, 14 ft.*lbf)

7. CONNECT FRONT NO. 1 STABILIZER BRACKET RH

HINT:

Install the RH side following the same procedures as the LH side.

8. INSTALL FRONT EXHAUST PIPE ASSEMBLY (See page EX-3)

9. INSTALL FLOOR PANEL BRACE FRONT (See page EX-4)

10. INSTALL FRONT STABILIZER LINK ASSEMBLY LH

- (a) Install the front stabilizer link LH with the 2 nuts.

Torque: 74 N*m (755 kgf*cm, 55 ft.*lbf)

HINT:

Use a 6 mm hexagon wrench to hold the stud if the ball joint turns together with the nut.

11. INSTALL NO. 2 TIE ROD END SUB-ASSEMBLY (See page PS-55)

12. INSTALL NO. 1 TIE ROD END SUB-ASSEMBLY (See page DS-16)

13. INSTALL FRONT WHEEL

Torque: 103 N*m (1,050 kgf*cm, 76 ft.*lbf)

14. INSPECT AND ADJUST FRONT WHEEL ALIGNMENT

- (a) Inspect and adjust the front wheel alignment (see page SP-2).

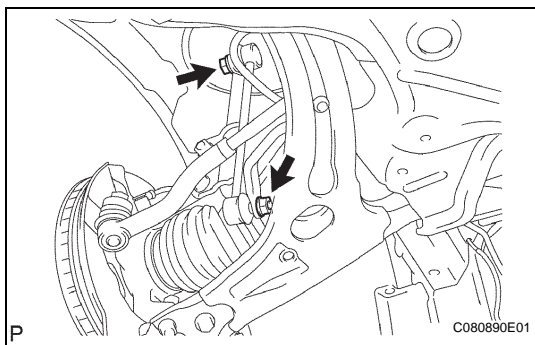
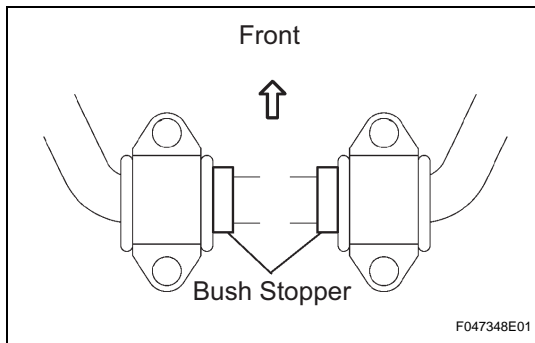

REAR SHOCK ABSORBER WITH COIL SPRING

COMPONENTS

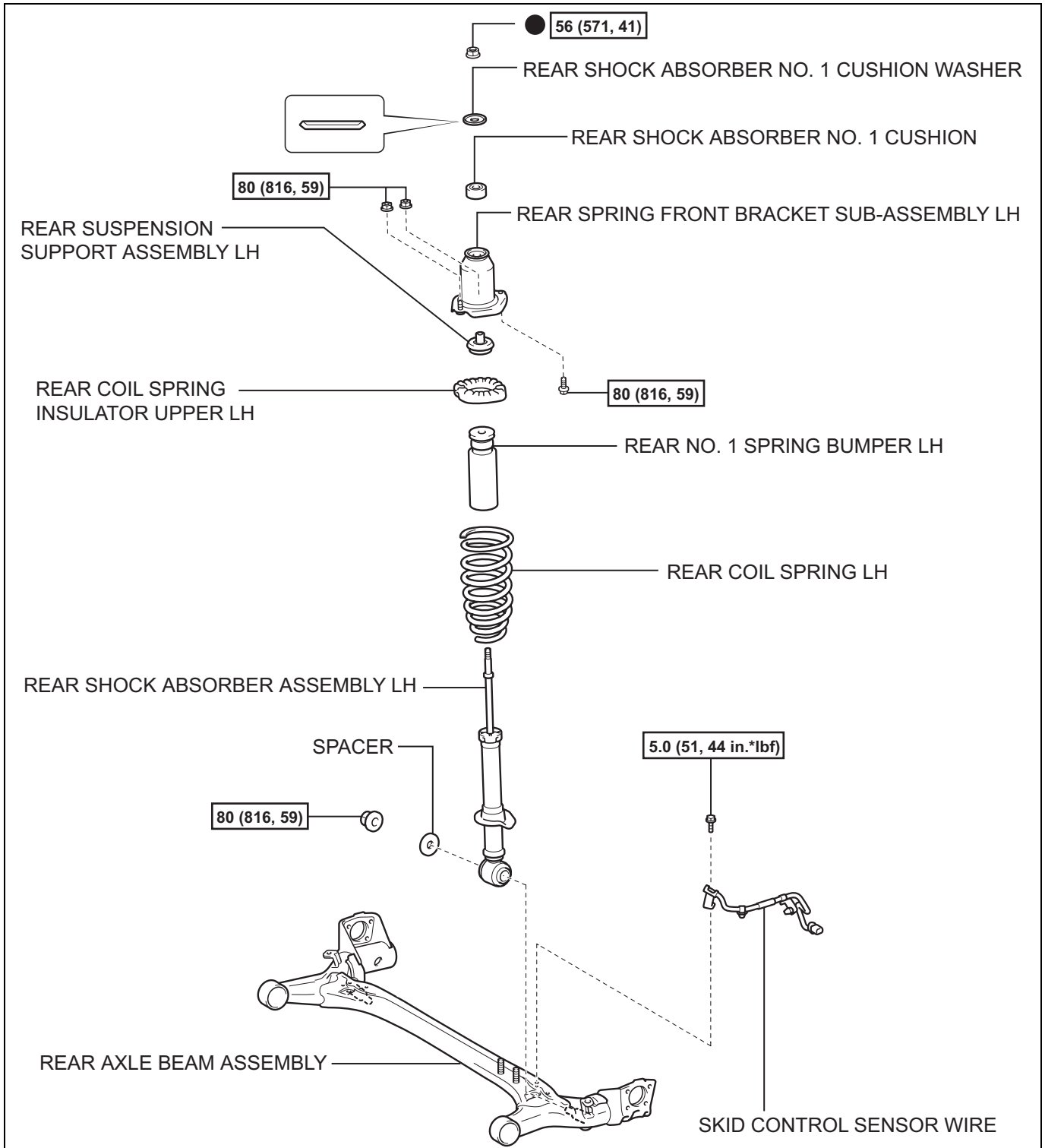

N*m (kgf*cm, ft.*lbf) : Specified torque

● Non-reusable part

SP

REMOVAL

1. REMOVE REAR NO. 2 FLOOR BOARD
2. REMOVE REAR DECK FLOOR BOX
3. REMOVE REAR DECK TRIM COVER (See page [IR-10](#))
4. REMOVE TONNEAU COVER ASSEMBLY
5. REMOVE REAR SEATBACK ASSEMBLY LH (See page [SE-15](#))
6. REMOVE REAR NO. 1 FLOOR BOARD (See page [IR-10](#))
7. REMOVE REAR SIDE SEATBACK FRAME LH (See page [IR-9](#))
8. REMOVE REAR NO. 4 FLOOR BOARD
9. REMOVE DECK FLOOR BOX LH
10. REMOVE DECK TRIM SIDE PANEL ASSEMBLY LH (See page [IR-11](#))
11. REMOVE BATTERY CARRIER BRACKET (See page [HB-91](#))
12. REMOVE REAR WHEEL
13. REMOVE REAR SHOCK ABSORBER WITH COIL SPRING
 - (a) Support the rear axle beam with a jack. Insert a wooden block between the jack and the rear axle beam to prevent damage.

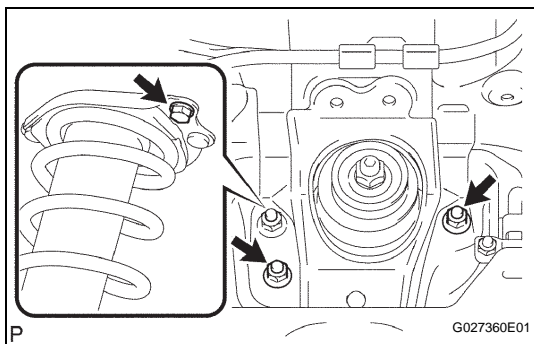
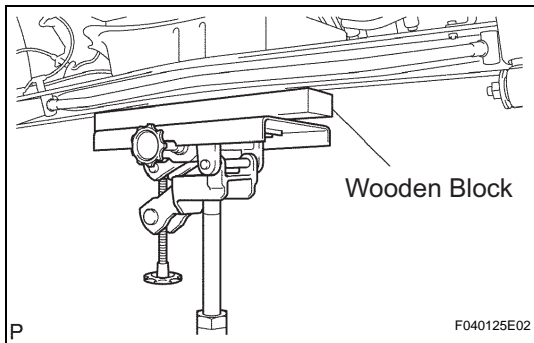

- (b) Remove the 2 nuts from the rear shock absorber with coil spring (upper side).
- (c) Remove the rear shock absorber with coil spring (upper side) bolt from the under-side of the vehicle.

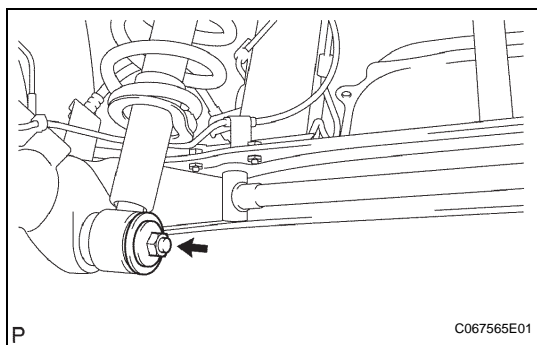

- (d) Remove the nut and spacer from the rear shock absorber with coil spring (lower side).
- (e) Remove the rear shock absorber with coil spring while slowly lowering the jack.

NOTICE:

Seat the jack so that no extra load is placed on the shock absorber on the opposite side of the vehicle.

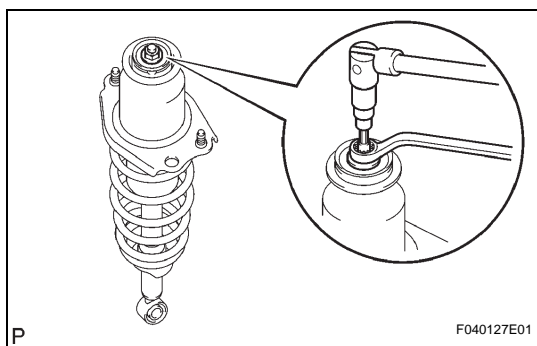
**DISASSEMBLY****1. REMOVE REAR SHOCK ABSORBER ASSEMBLY LH**

- (a) Use a 6 mm socket hexagon wrench to secure the piston rod of the shock absorber and loosen the nut.

NOTICE:

- Do not remove the nut.
- Sufficiently insert the hexagon wrench.

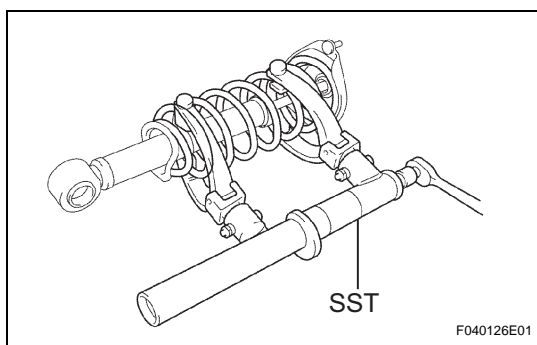

- (b) Attach SST to the coil spring so that the upper and lower hooks of the installed area are as wide as possible.

SST 09727-30021 (09727-00010, 09727-00021, 09727-00031)

- (c) Compress the coil spring until it moves freely.

NOTICE:

Do not use an impact wrench. It will damage SST.

- (d) Remove the nut.

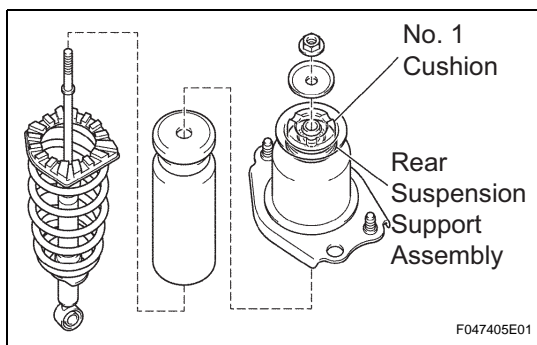

- (e) Remove the No. 1 cushion washer, No. 1 cushion, rear spring front bracket, rear suspension support, rear coil spring insulator upper and rear No. 1 spring bumper.

HINT:

The shock absorber can be replaced without removing the No. 1 cushion and rear suspension support from the rear spring front bracket.

- (f) Release SST and remove it from the coil spring after removing the coil spring from the shock absorber.

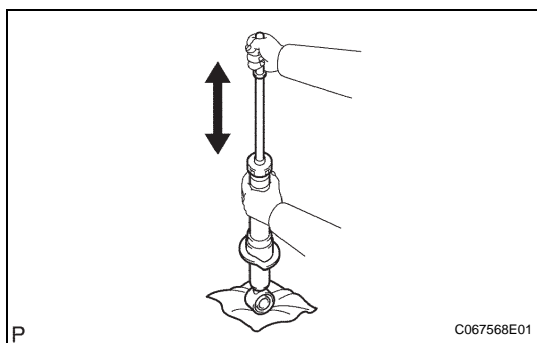
**INSPECTION****1. INSPECT REAR SHOCK ABSORBER ASSEMBLY LH**

- (a) Compress and extend the shock absorber rod, and check that there is no abnormal resistance or unusual sound.

If there is any abnormality, replace the shock absorber with a new one.

NOTICE:

When disposing of the shock absorber, see DISPOSAL (see page SP-36).

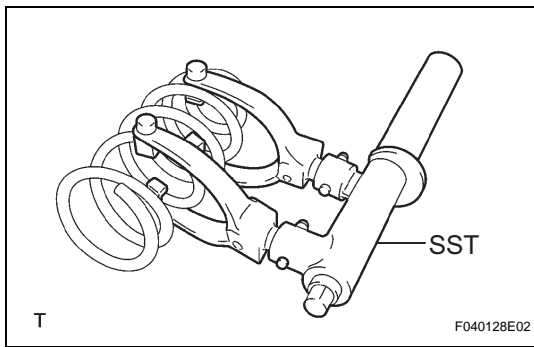

REASSEMBLY

1. INSTALL REAR SHOCK ABSORBER ASSEMBLY LH

- (a) Using SST, compress the coil spring.
SST 09727-30021 (09727-00010, 09727-00021, 09727-00031)

NOTICE:

Do not use an impact wrench. It will damage SST.

HINT:

The coil spring can also be installed/removed using the hydraulic spring compressor.

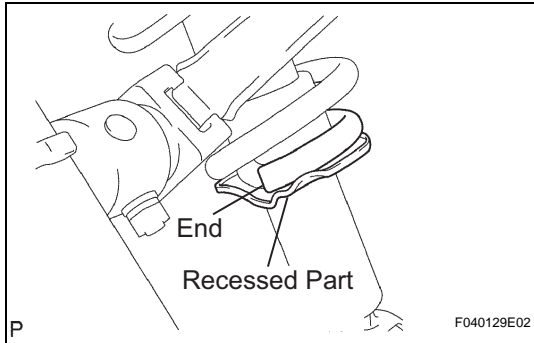

- (b) Fit the coil spring end into the recessed part of the shock absorber assy lower seat.
 (c) Fit the rear coil spring insulator upper to the rear spring front bracket.

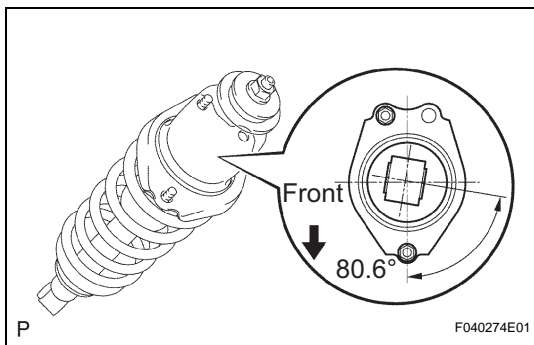

- (d) Install the rear No. 1 spring bumper, rear suspension support, rear spring front bracket, No. 1 cushion and No. 1 cushion washer.

NOTICE:

- Install the rear spring front bracket so that it is aligned with the shock absorber lower bush, as shown in the illustration.
- Install the No. 1 cushion washer with the protruding portion facing down.

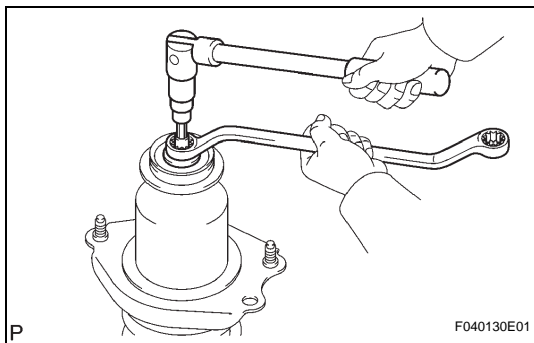

- (e) Use a 6 mm socket hexagon wrench to fix the shock absorber piston rod and tighten the nut.

Torque: 56 N*m (571 kgf*cm, 41 ft.*lbf)

NOTICE:

Sufficiently insert the hexagon wrench.

- (f) Release SST and remove it from the coil spring.

NOTICE:

- Do not use an impact wrench. It will damage SST.
- Remove SST while confirming the direction of the rear spring front bracket.

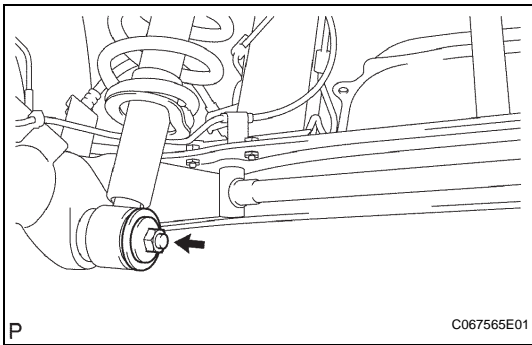

INSTALLATION

1. INSTALL REAR SHOCK ABSORBER WITH COIL SPRING

- (a) Install the rear shock absorber with coil spring to the rear axle beam. Place the spacer and temporarily tighten the nut.
- (b) Install the rear shock absorber with coil spring (upper side) to the vehicle by slowly raising the rear axle beam on a jack. Insert a wooden block between the jack and the rear axle beam to prevent damage.

NOTICE:

- Do not raise the rear axle beam more than necessary.
- Securely insert the rear spring front bracket stud bolt into the vehicle.

- (c) Tighten the bolt and 2 nuts of the rear shock absorber with coil spring (upper side).

Torque: 80 N*m (816 kgf*cm, 59 ft.*lbf)

2. INSTALL REAR WHEEL

- (a) Install the rear wheel.
Torque: 103 N*m (1,050 kgf*cm, 76 ft.*lbf)

3. STABILIZE SUSPENSION

- (a) After lowering the vehicle, bounce the vehicle up and down to stabilize the rear suspension.

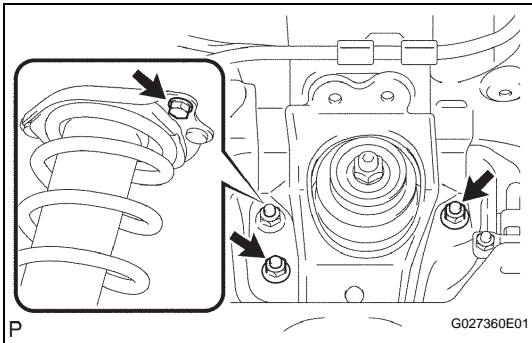

4. FULLY TIGHTEN REAR SHOCK ABSORBER WITH COIL SPRING

- (a) Tighten the rear shock absorber with coil spring (lower side) installation nut.

Torque: 80 N*m (816 kgf*cm, 59 ft.*lbf)

NOTICE:

Ensure the vehicle is lowered to the ground.

5. INSTALL BATTERY CARRIER BRACKET (See page [HB-97](#))

6. INSTALL DECK TRIM SIDE PANEL ASSEMBLY LH (See page [IR-15](#))

7. INSTALL DECK FLOOR BOX LH

8. INSTALL REAR NO. 4 FLOOR BOARD

9. INSTALL REAR SIDE SEATBACK FRAME LH (See page [IR-17](#))

10. INSTALL REAR NO. 1 FLOOR BOARD (See page [IR-16](#))

11. INSTALL REAR SEATBACK ASSEMBLY LH (See page [SE-22](#))

12. INSTALL TONNEAU COVER ASSEMBLY

13. INSTALL REAR DECK TRIM COVER (See page [IR-16](#))

14. INSTALL REAR DECK FLOOR BOX

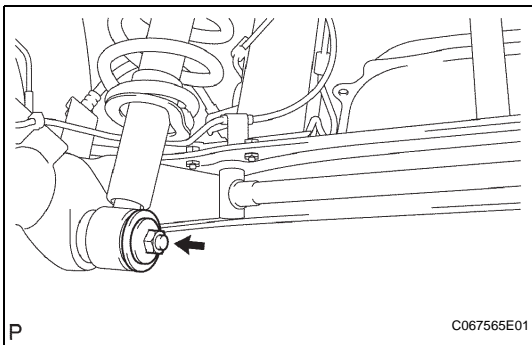

15. INSTALL REAR NO. 2 FLOOR BOARD**16. INSPECT REAR WHEEL ALIGNMENT**

- (a) Inspect the rear wheel alignment (see page [SP-10](#)).

17. PERFORM INITIALIZATION

- (a) Perform the initialization (see page [IN-32](#)).

NOTICE:

Certain systems need to be initialized after disconnecting and reconnecting the cable from the negative (-) battery terminal.

DISPOSAL**1. DISPOSE OF REAR SHOCK ABSORBER ASSEMBLY LH**

- (a) Fully extend the shock absorber rod.
(b) Make a hole in the cylinder somewhere between A and B shown in the illustration to discharge the gas inside using a drill.

CAUTION:

Be careful when drilling because shards of metal may fly about, so always use the proper safety equipment.

NOTICE:

The gas is colorless, odorless and non-poisonous.

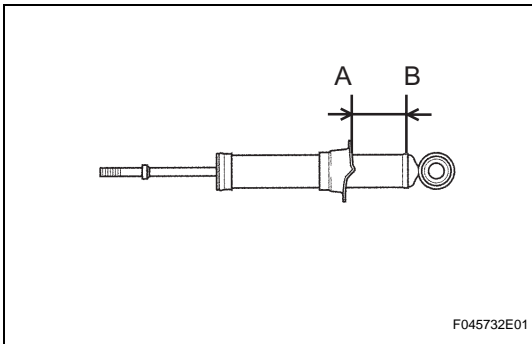

REAR AXLE BEAM

COMPONENTS

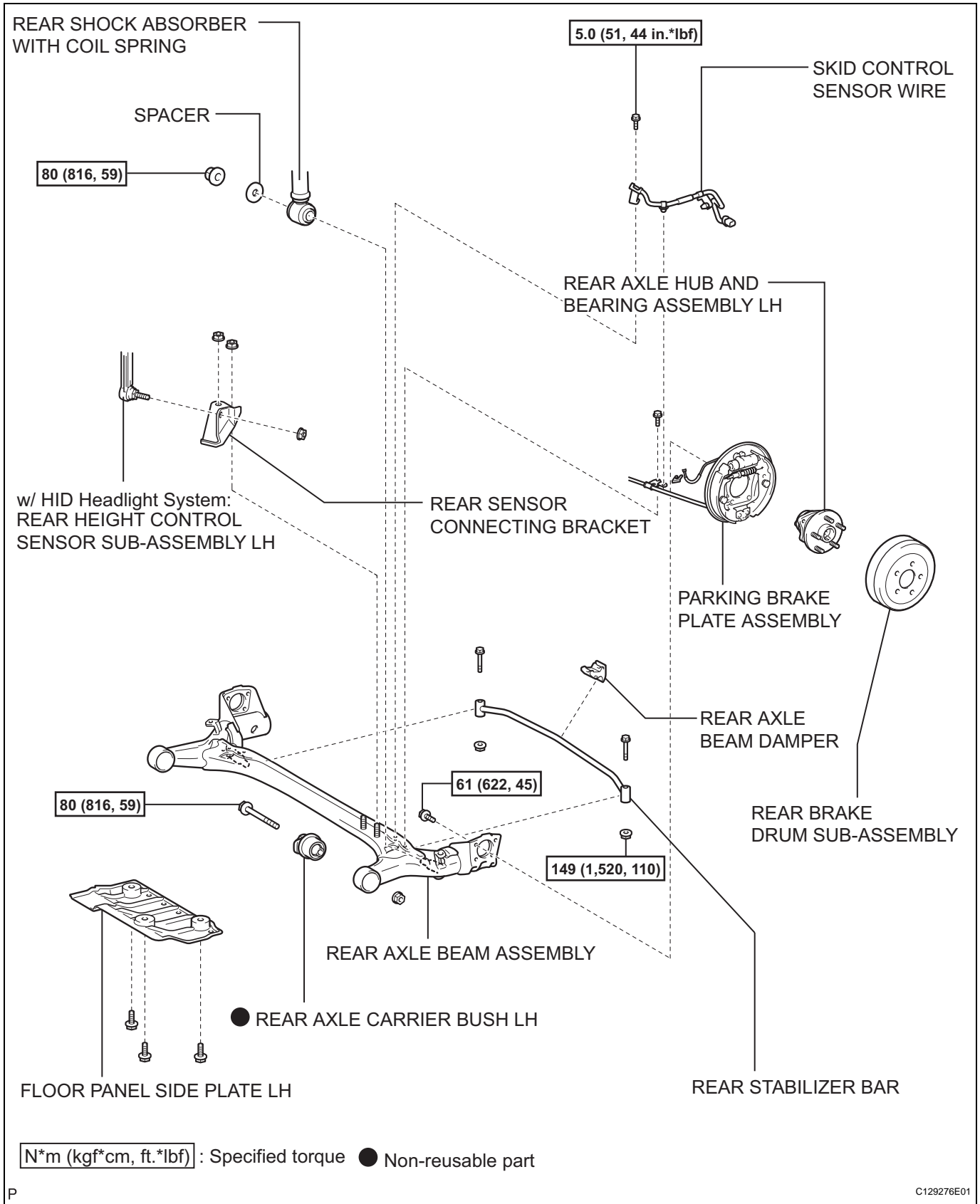

SP

REMOVAL

1. REMOVE REAR WHEEL
2. REMOVE FLOOR PANEL SIDE PLATE LH
(a) Remove the 3 bolts and floor panel side plate.
3. REMOVE FLOOR PANEL SIDE PLATE RH
(a) Remove the 3 bolts and floor panel side plate.

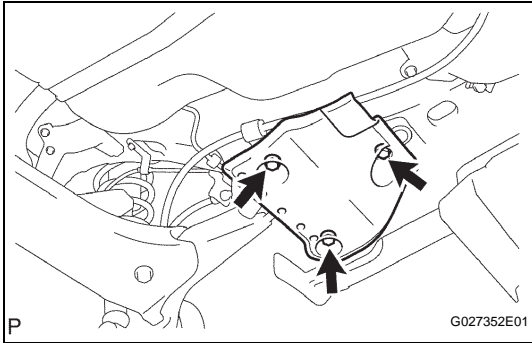

4. REMOVE REAR HEIGHT CONTROL SENSOR SUB-ASSEMBLY LH (w/ HID Headlight System)
(a) Remove the nut and height control sensor.

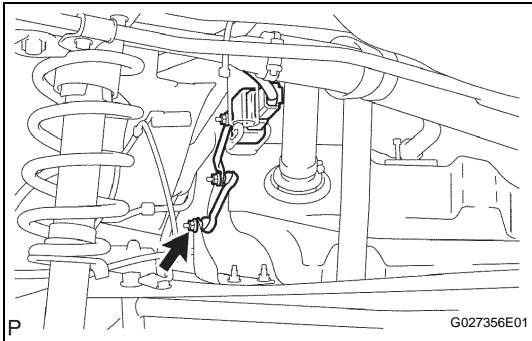

5. REMOVE REAR SENSOR CONNECTING BRACKET (w/ HID Headlight System)
(a) Remove the 2 nuts and sensor connecting bracket.

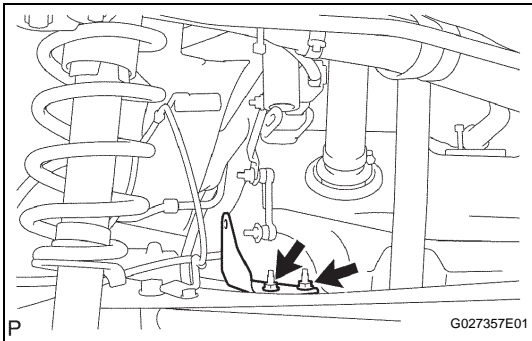

6. REMOVE REAR BRAKE DRUM SUB-ASSEMBLY (See page [BR-47](#))

7. DISCONNECT SKID CONTROL SENSOR WIRE
(a) Remove the 2 bolts and clip, and disconnect the skid control sensor wire and parking brake cable from the rear axle beam.

NOTICE:

- Ensure no foreign matter is on the end of the skid control sensor wire.
- Ensure that the skid control sensor wire is disconnected from the rear axle beam.

HINT:

Use the same procedures for the RH side and LH side.

8. REMOVE REAR AXLE BEAM DAMPER (See page [SP-44](#))
9. REMOVE REAR STABILIZER BAR (See page [SP-45](#))

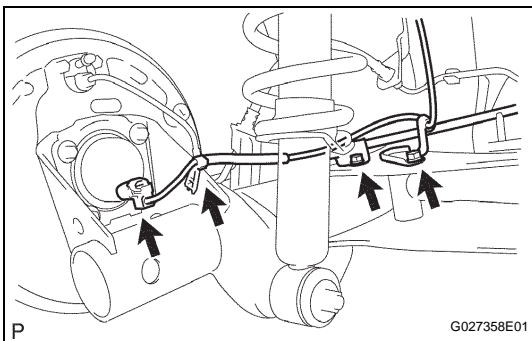

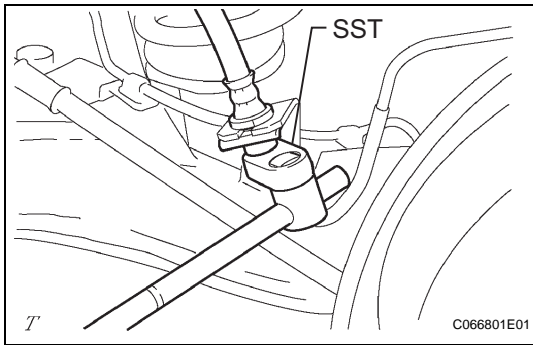
**10. DISCONNECT REAR NO. 4 BRAKE TUBE**

- (a) Using SST, disconnect the rear brake tube from the flexible hose.

SST 09023-00101

NOTICE:

Do not damage the rear brake tube or flexible hose.

- (b) Remove the clip.

11. DISCONNECT REAR NO. 3 BRAKE TUBE**HINT:**

Use the same procedures as the rear No. 4 brake tube.

12. REMOVE REAR AXLE HUB AND BEARING ASSEMBLY LH

- (a) Remove the 4 bolts. Remove the axle hub and bearing and parking brake plate from the rear axle beam.

NOTICE:

- Do not twist the parking brake cable.
- Use rope, etc. to suspend the parking brake plate.

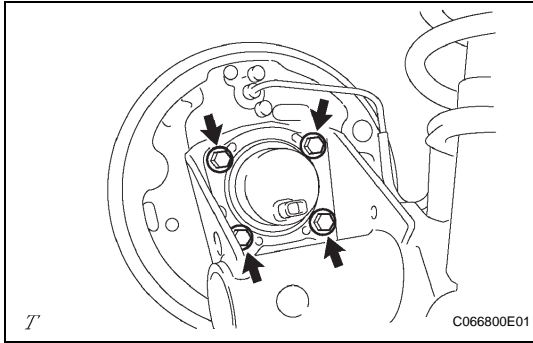
**13. REMOVE REAR AXLE HUB AND BEARING ASSEMBLY RH****HINT:**

Use the same procedures for the RH side and LH side.

14. DISCONNECT REAR SHOCK ABSORBER WITH COIL SPRING

- (a) Remove the 2 nuts from the left and right sides.
 (b) Disconnect the rear shock absorber with coil springs (lower side) from the rear axle beam.

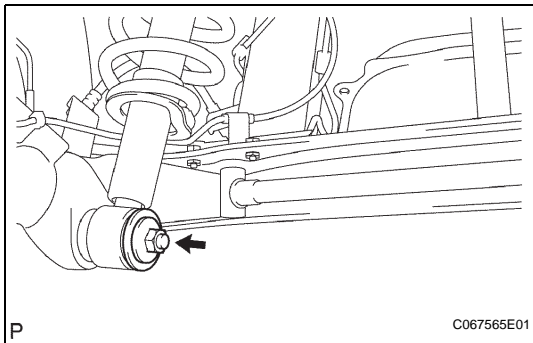
**15. REMOVE REAR AXLE BEAM ASSEMBLY**

- (a) Support the rear axle beam with a jack. Insert a wooden block between the jack and the center of the rear axle beam to prevent damage.

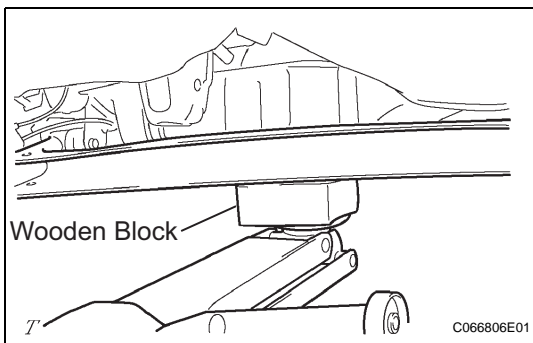

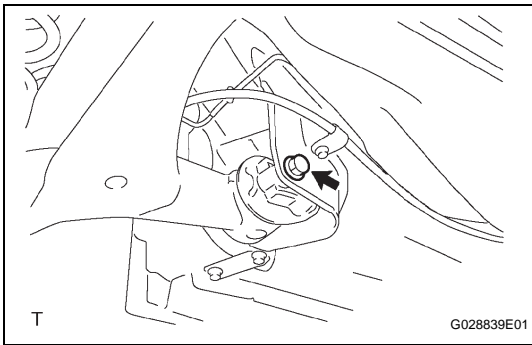

- (b) Remove the 2 bolts and 2 nuts from the left and right sides.

NOTICE:

Keep the nut from rotating when removing the bolt.

- (c) Remove the rear axle beam by slowly lowering the jack.

NOTICE:

Ensure that the skid control sensor wire is completely disconnected from the rear axle beam.

DISASSEMBLY**1. REMOVE REAR AXLE CARRIER BUSH LH**

- (a) Place a matchmark on the rear axle beam after aligning it with the bush recess.
- (b) Make 2 bends in the rim of the bush using a chisel and hammer.
- (c) Using SST, remove the bush from the rear axle beam.

SST 09950-40011 (09951-04020, 09952-04010, 09953-04030, 09954-04020, 09955-04051, 09957-04010, 09958-04011), 09950-60010 (09951-00630)

NOTICE:

- Do not erase the matchmark on the rear axle beam when removing the bush.
- Apply chassis black if the rear axle beam is scratched.

2. REMOVE REAR AXLE CARRIER BUSH RH**HINT:**

Use the same procedures for the RH side and LH side.

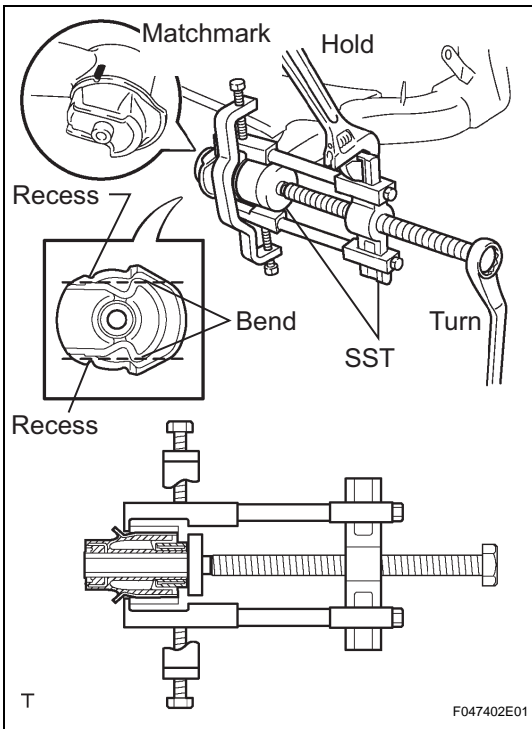

REASSEMBLY

1. INSTALL REAR AXLE CARRIER BUSH LH

- (a) When replacing only the bush:
- (1) Temporarily install a new bush recess by aligning it with the matchmark on the rear axle beam.

NOTICE:

Install the bush in the same direction as before it was removed.

- (b) When replacing the rear axle beam:
- (1) Temporarily install a new bush as shown in the illustration.

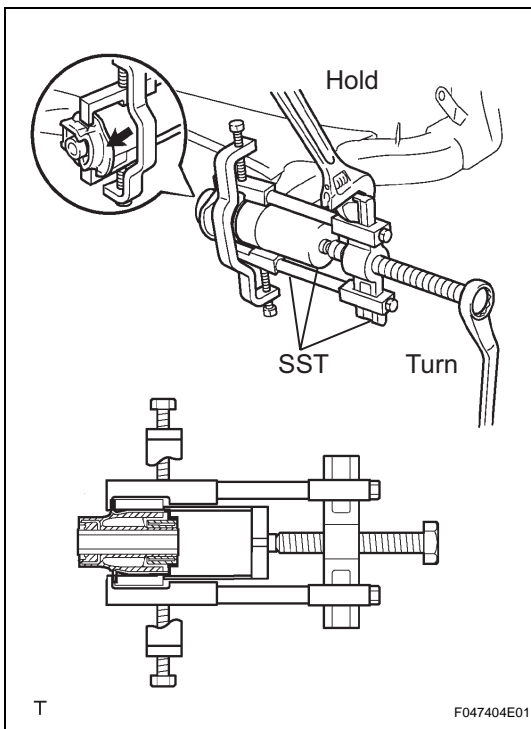
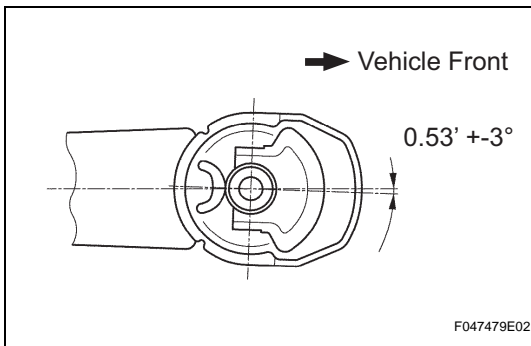

- (c) Using SST, install the bush to the rear axle beam.
SST 09950-40011 (09951-04020, 09952-04010, 09953-04030, 09954-04020, 09955-04051, 09957-04010, 09958-04011), 09950-60010 (09951-00620), 09710-04101

NOTICE:

- Hang the claw of SST to the bush firmly.
- Do not damage the rubber sections indicated by the arrow in the illustration when installing the bush.

2. INSTALL REAR AXLE CARRIER BUSH RH

HINT:

Use the same procedures for the RH side and LH side.

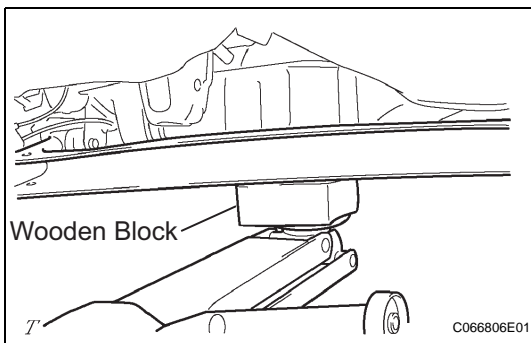

INSTALLATION

1. TEMPORARILY TIGHTEN REAR AXLE BEAM ASSEMBLY

- (a) Support the rear axle beam with a jack. Insert a wooden block between the jack and the center of the rear axle beam to prevent damage.
- (b) Slowly raise the jack to install the rear axle beam on the vehicle. Insert the 2 bolts from the inner side of the vehicle and temporarily tighten them with the 2 nuts (1 nut and bolt each for the left and right sides).

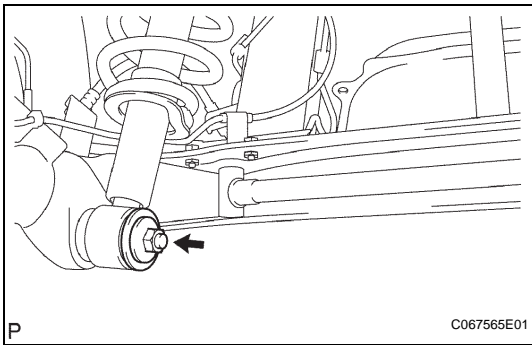

2. TEMPORARILY TIGHTEN REAR SHOCK ABSORBER WITH COIL SPRING

- (a) Install the left and right side rear shock absorber with coil spring (lower side) to the rear axle beam. Temporarily tighten the nuts.

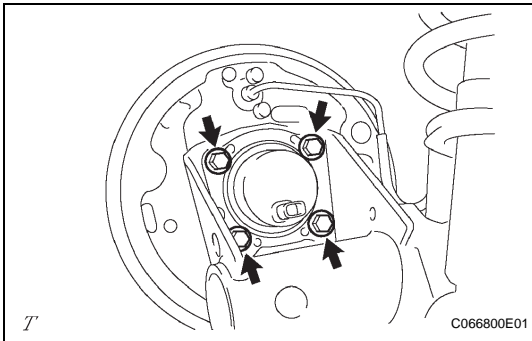

3. INSTALL REAR AXLE HUB AND BEARING ASSEMBLY LH

- (a) Install the parking brake plate and the axle hub and bearing to the rear axle beam with the 4 bolts.
Torque: 61 N*m (622 kgf*cm, 45 ft.*lbf)

4. INSTALL REAR AXLE HUB AND BEARING ASSEMBLY RH

HINT:

Use the same procedures for the RH side and LH side.

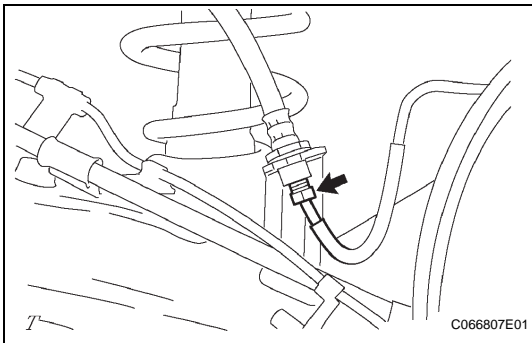

5. CONNECT REAR NO. 4 BRAKE TUBE

- (a) Temporarily tighten the rear brake tube and flexible hose.

NOTICE:

- Do not damage the rear brake tube or flexible hose.
- Replace the rear brake tube and flexible hose with new parts if they are damaged.

- (b) Install the rear brake tube to the rear axle beam and secure it with the clip.

- (c) Fully tighten the rear brake tube using SST.

SST 09023-00101

Torque: 15 N*m (155 kgf*cm, 11 ft.*lbf)

6. CONNECT REAR NO. 3 BRAKE TUBE

HINT:

Use the same procedures as the rear No. 4 brake tube.

7. INSTALL REAR STABILIZER BAR (See page [SP-45](#))

8. INSTALL REAR AXLE BEAM DAMPER (See page [SP-45](#))

9. CONNECT SKID CONTROL SENSOR WIRE

- (a) Install the skid control sensor wire and parking brake cable to the rear axle beam using the 2 bolts and clip.

Torque: 5.4 N*m (55 kgf*cm, 48 in.*lbf) for bolt A
5.0 N*m (51 kgf*cm, 44 in.*lbf) for bolt B

NOTICE:

Do not twist the skid control sensor wire while installing it.

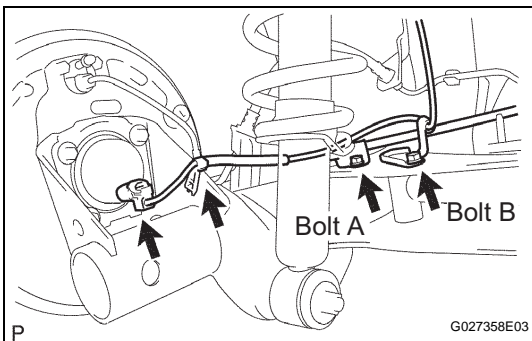
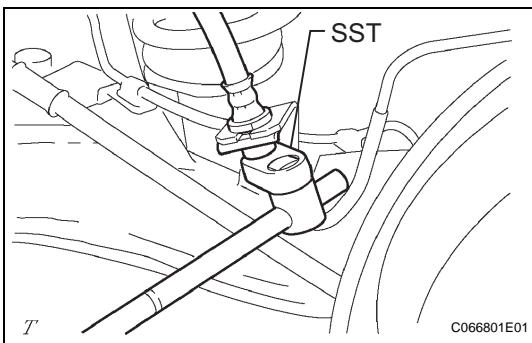

HINT:

Use the same procedures for the RH side and LH side.

10. INSTALL REAR BRAKE DRUM SUB-ASSEMBLY (See page BR-53)

11. INSTALL FRONT WHEEL

- (a) Install the rear wheel.

Torque: 103 N*m (1,050 kgf*cm, 76 ft.*lbf)

12. STABILIZE SUSPENSION

- (a) After jacking down the vehicle, bounce the vehicle up and down to stabilize the rear suspension.

13. FULLY TIGHTEN REAR AXLE BEAM ASSEMBLY

- (a) Hold the nut and rotate the bolt to fully tighten the rear axle beam on the LH side.

Torque: 85 N*m (867 kgf*cm, 63 ft.*lbf)

NOTICE:

Ensure the vehicle is lowered to the ground.

HINT:

Use the same procedures for the RH side and LH side.

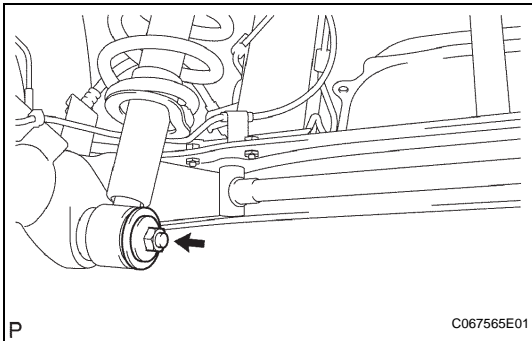
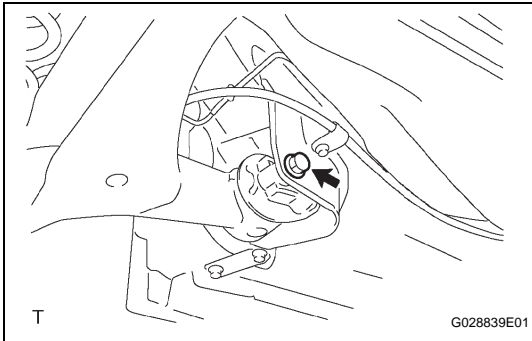

14. FULLY TIGHTEN REAR SHOCK ABSORBER WITH COIL SPRING

- (a) Install the rear shock absorber with coil spring (lower side) and tighten the nut.

Torque: 80 N*m (816 kgf*cm, 59 ft.*lbf)

NOTICE:

Ensure the vehicle is lowered to the ground.

HINT:

Use the same procedures for the RH side and LH side.

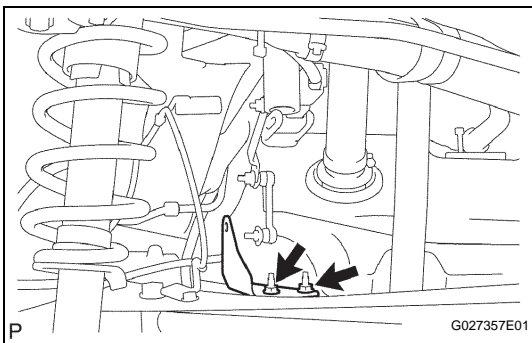

15. INSTALL REAR SENSOR CONNECTING BRACKET (w/ HID Headlight System)

- (a) Install the sensor connecting bracket with the 2 nuts.

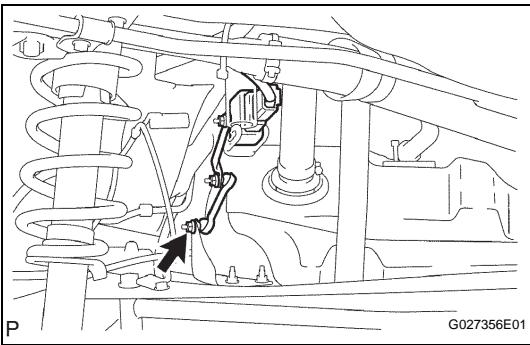

16. INSTALL REAR HEIGHT CONTROL SENSOR SUB-ASSEMBLY LH (w/ HID Headlight System)

- (a) Install the height control sensor with the nut.

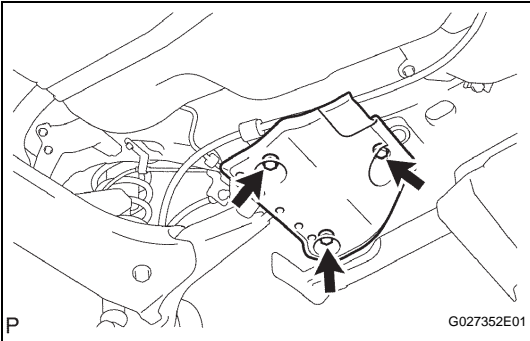

17. INSTALL FLOOR PANEL SIDE PLATE LH

- (a) Install the floor panel side plate with the 3 bolts.

18. INSTALL FLOOR PANEL SIDE PLATE RH

- (a) Install the floor panel side plate with the 3 bolts.

19. BLEED BRAKE LINE

- (a) Bleed brake line (see page [BR-3](#)).

20. INSPECT BRAKE FLUID

21. INSPECT REAR WHEEL ALIGNMENT

- (a) Inspect the rear wheel alignment (see page [SP-10](#)).

22. PERFORM INITIALIZATION

- (a) Perform the initialization (see page [IN-32](#)).

NOTICE:

Certain systems need to be initialized after disconnecting and reconnecting the cable from the negative (-) battery terminal.

23. ADJUST HEADLIGHT AIM ONLY (See page [LI-80](#))

24. CHECK SPEED SENSOR SIGNAL

- (a) Check the speed sensor signal (see page [BC-37](#)).

REAR STABILIZER BAR

COMPONENTS

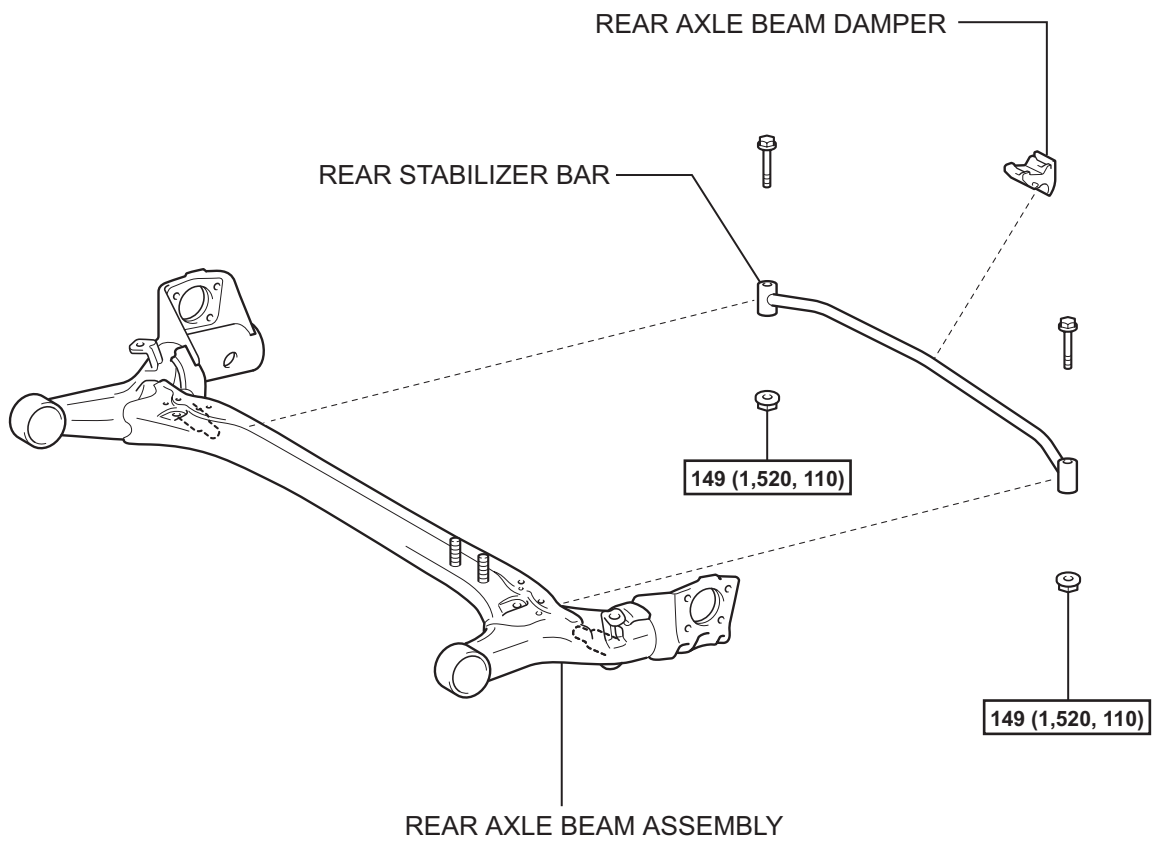

N*m (kgf*cm, ft.*lbf) : Specified torque

REMOVAL

1. **REMOVE REAR AXLE BEAM DAMPER**
 - (a) Remove the rear axle beam damper from the rear axle beam.
2. **REMOVE REAR STABILIZER BAR**
 - (a) Remove the 2 bolts, 2 nuts and stabilizer bar.

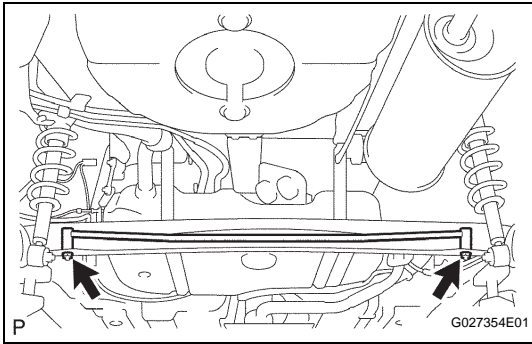

INSTALLATION

1. **INSTALL REAR STABILIZER BAR**
 - (a) Install the stabilizer bar so that the mark position faces towards the vehicle's rear right. Hold the bolts and tighten the nuts.
Torque: 149 N*m (1,520 kgf*cm, 110 ft.*lbf)

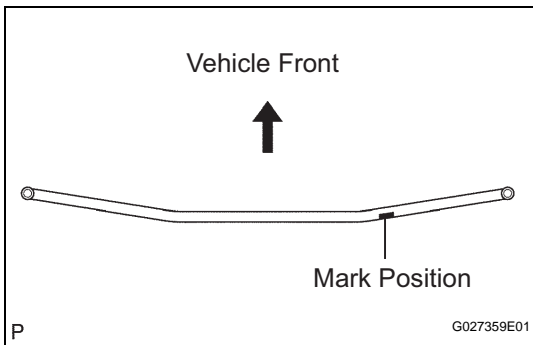

2. **INSTALL REAR AXLE BEAM DAMPER**
 - (a) Install the rear axle beam damper to the center of the rear axle beam.

